

SB-10044297-4409

Countries: CANADA, UNITED STATES, MEXICO
Availability: ISIS, Bus ISIS, FleetISIS
Major System: BUS BODY
Current Language: English
Other Languages: NONE
Viewed: 162

Document ID: IK2200117
Revision: 0
Created: 5/8/2012
Last Modified: 6/4/2012
Author: Matthew Boyer

[Less Info](#)
[Hide Details](#)

Coding Information

Copy Link 	Copy Relative Link 	Bookmark View My Bookmarks	Add to Favorites 	Print 	Provide Feedback 	Helpful 43	Not Helpful 7
----------------------	-------------------------------	--	-----------------------------	------------------	-----------------------------	--------------------------	-----------------------------

Title: Motor Replacement and Door Adjustment Procedure for Electric IC Bus Doors

Applies To: BE, CE, FE, and RE Buses with the Current Electric Door Motor

DESCRIPTION

This iKnow document explains the replacement and adjustment process of the electric drive motor for the pupil door installed on CE busses. This process has changed from that of previous models.



WARNING:

To prevent electrical shock that could result in property damage, personal injury or death, always disconnect the negative battery terminal before working on the electrical system.

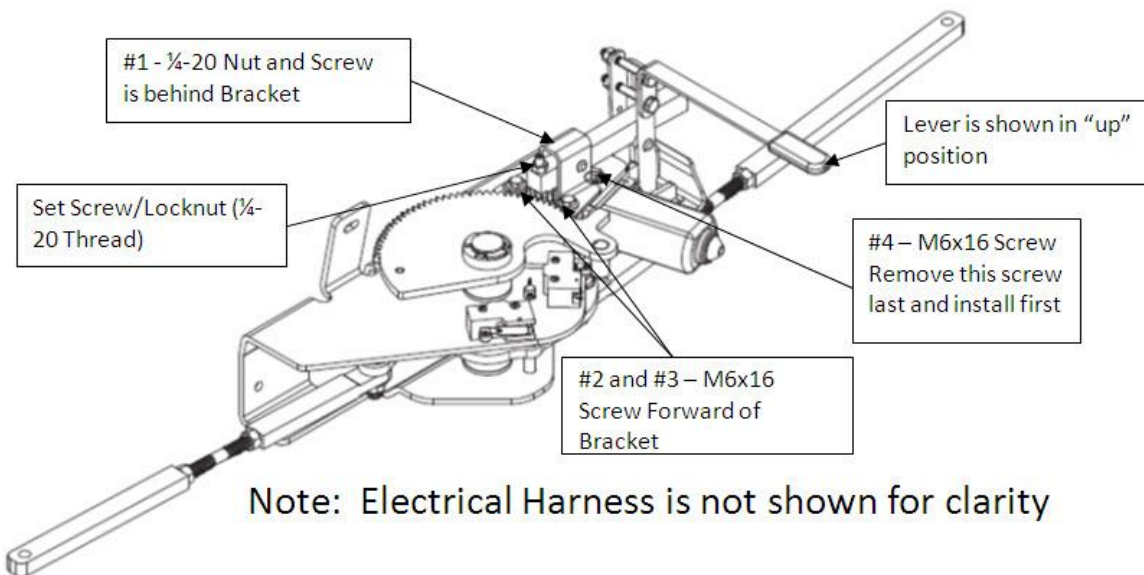

REMOVAL

1. Disconnect the two electrical leads to the electric door actuator.
2. Move the door manual release handle to the right into the run position.
3. Remove the 1/4-20 nut and bolt that holds the lever bracket to the base structure.
4. Remove two M6x16 screws and washers that hold the lever bracket to the base structure and motor

- A. Remove the lever bracket from the assembly.
 - B. Remove the compression spring from the assembly.
5. Remove the final M6-16 screw holding the motor to the base assembly.

Fastener removal order:

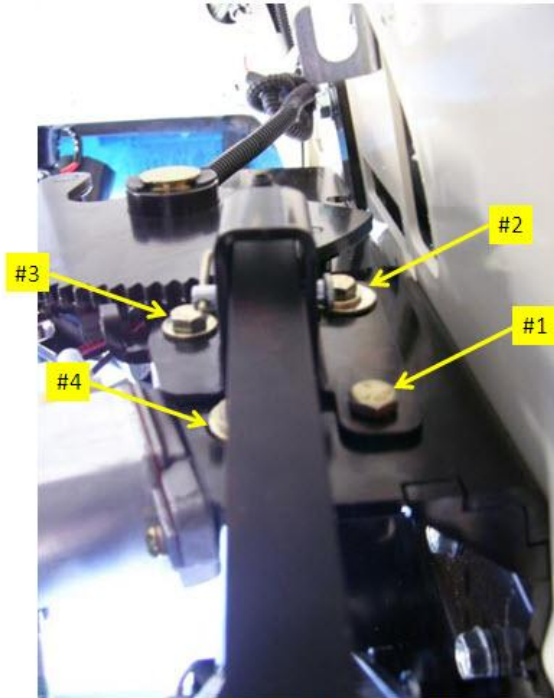

Note: Reinstall in reverse order.

INSTALLATION

1. Position the new motor into the base assembly and install one M6x16 screw and washer into the motor.
2. Rotate the motor so that the pinion gear engages with the bell crank gear.
3. Place the compression spring into the clearance hole in the base structure, on top of the motor gearbox.
4. Place the lever bracket onto the top of the base structure, making sure that the lever end is positioned through the release lever.
5. Install the two remaining M6-16 screws and washers through the lever bracket and into the motor.
6. Install the 1/4-20 nut and bolt through the remaining hole in the lever bracket and base structure.
7. Tighten all four fasteners to **60 to 100 in-lbs.**
8. Adjust the socket set screw so that the doors can be operated manually when the lever is in the up position. When the lever is moved to the down position, the motor will be engaged,
9. Tighten the locknut on the set screw to **60 to 100 in-lbs.**
10. Reconnect the electrical leads to the motor terminals such that the **RED** is on the **TOP**, and the **BLACK** is on the **BOTTOM** terminal.
11. Verify the micro switch position and adjust the door as required to complete the open and close operations and to disengage the motor at the end of each stroke.

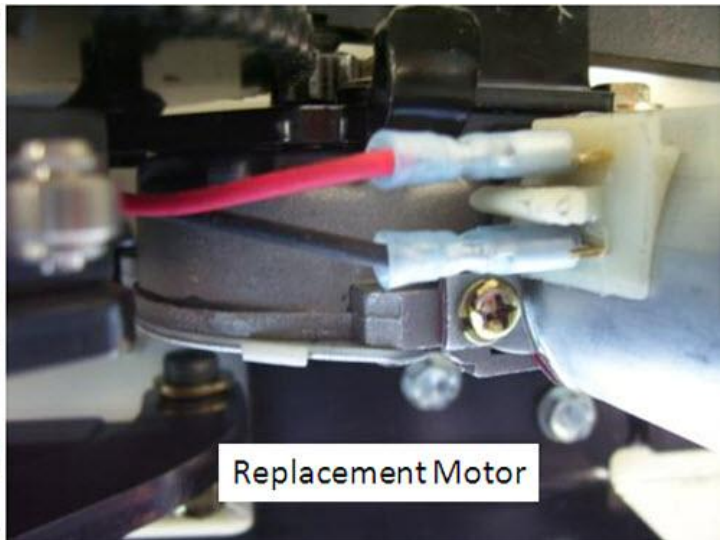
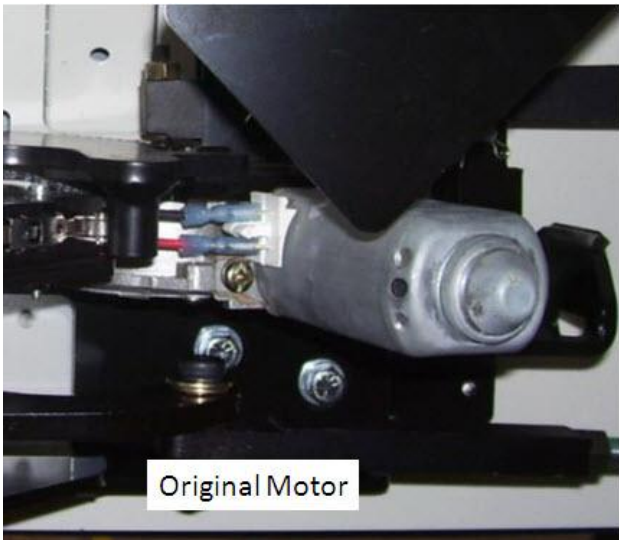

 Hide Details

Feedback Information

Viewed: 161

Helpful: 43

Not Helpful: 7

No Feedback Found