



Date	Group	No.	Release	Page
4.2012	212	002	01	1(18)

Oil Seepage at Flywheel Housing

SB-10044248-9001

CHU, CXU, GU
US07
MP8

FSB 212-002, Oil Seepage at Flywheel Housing

(April 2012)

This bulletin does not apply to MACK Trucks Australia.

Aftermarket has requested a solution to solve leaking flywheel housings. There is an area near the PTO where the sealing between the flywheel housing and the timing gear plate needs improvement. This problem has already been solved in production, but the production solution is not compatible with previous generation flywheel housings.

A bracket has been created to reinforce the timing gear plate in this area. This reinforcement increases the contact pressure in this area above the current production solution and will eliminate the leaks. A kit has been created to solve each of the potential aftermarket scenarios.

Required Parts

Description	Part Number
Flywheel Hsg Bracket Kit	21676748

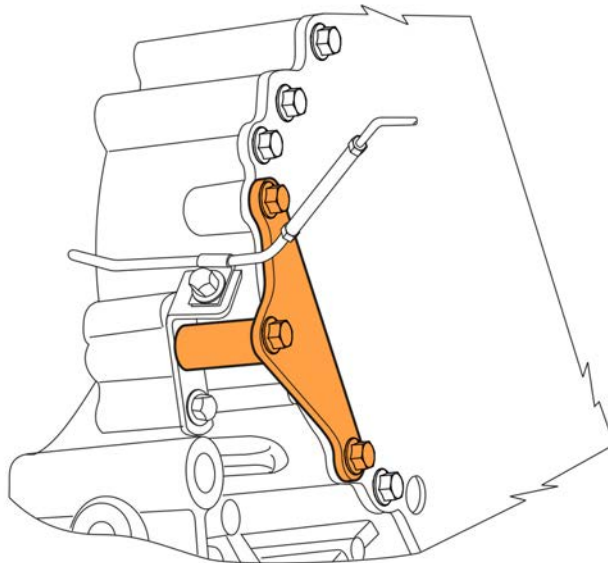

W4070269

Note: Information is subject to change without notice.
Illustrations are used for reference only and may differ slightly from the actual vehicle being serviced. However, key components addressed in this information are represented as accurately as possible.

You must read and understand the precautions and guidelines in Service Information, group 20, "General Safety Practices, Engine" before performing this procedure. If you are not properly trained and certified in this procedure, ask your supervisor for training before you perform it.

Removal

- 1 Unlatch and raise the hood.
- 2 Disconnect the battery cables.
- 3 Remove the right side fairing under the passenger door (if equipped).
- 4 Remove the right side inner fender.
- 5 Drain the engine coolant.
- 6 Remove the air filter housing and fresh air pipe.

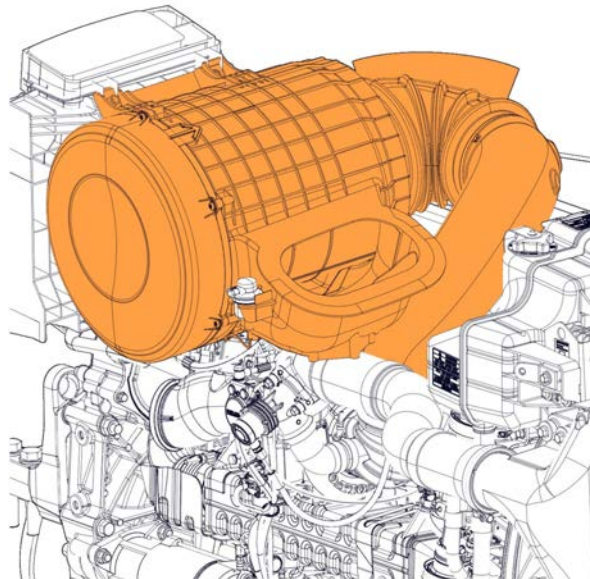

W2070256

7 Disconnect the AHI - coolant lines.

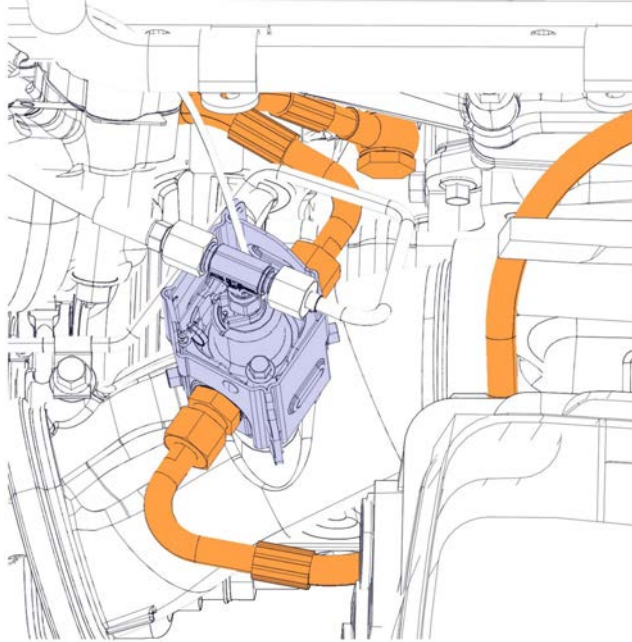

W2070258

- 8 Disconnect the AHI - fuel and air line and remove the mounting bracket at cylinder head.

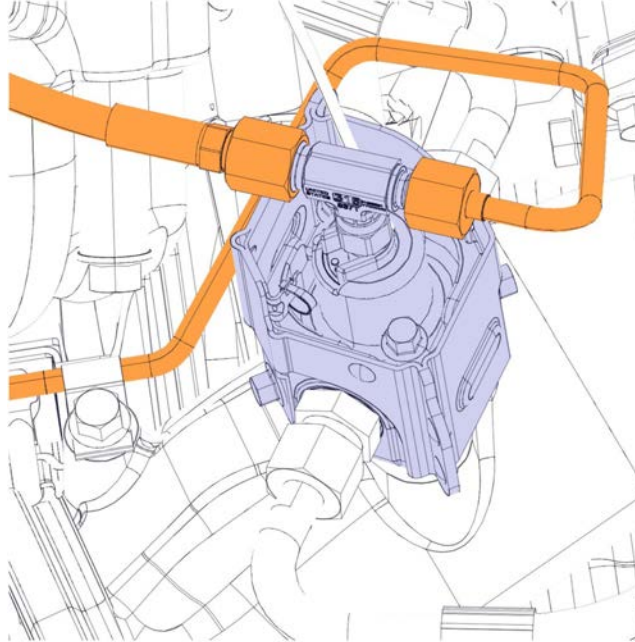

W2070259

- 9 Remove the AHI wire harness from the clamps on the valve cover.

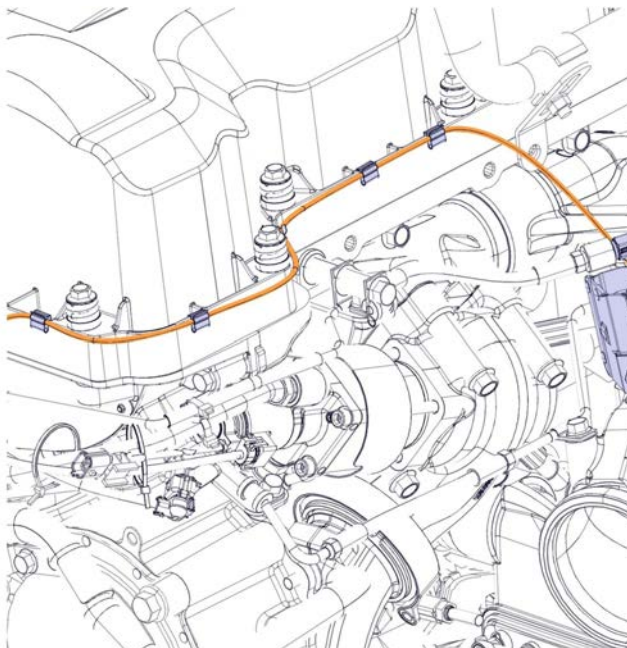

W4070265

10 Disconnect the difusser between the turbo and flex pipe and lay it to the side.

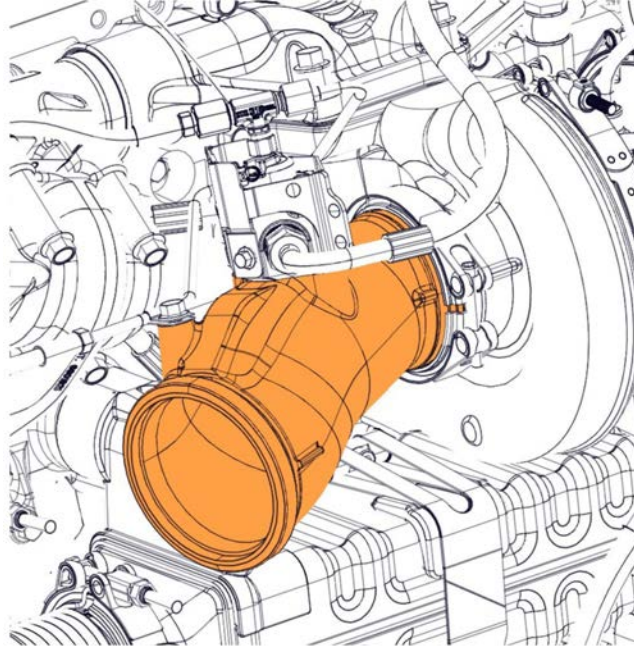

W2070257

11 Remove the EGR hot pipe.

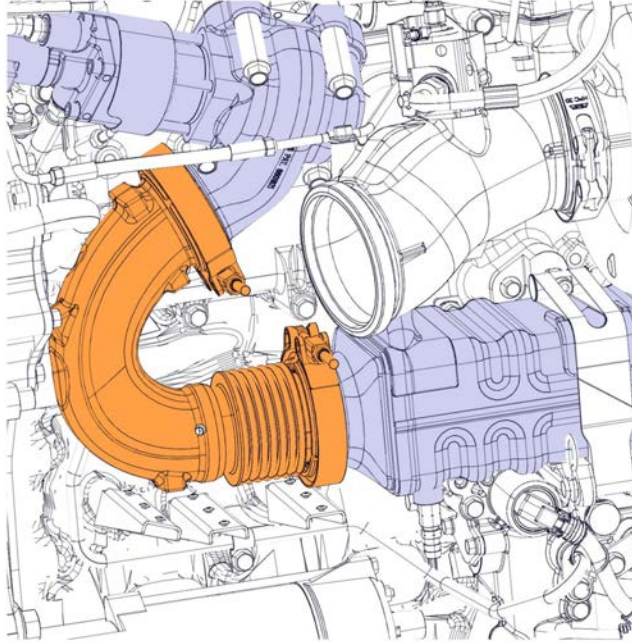

W2070267

12 Remove the EGR heat shield (if equipped).

13 Remove the sound plate from the timing gear plate.

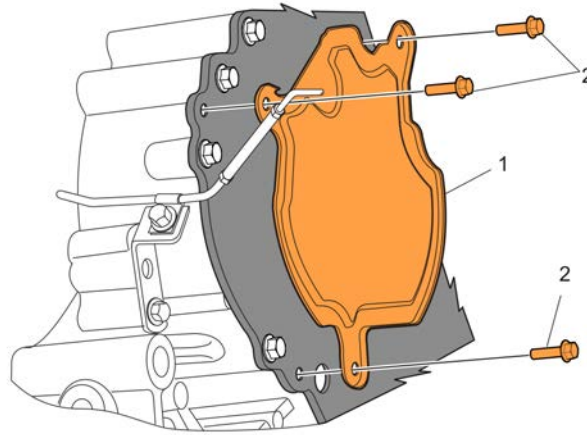

W4070254

Item Number	Description
1	Sound Plate
2	Sound Plate Screws

14 Install the stiffening bracket, using the correct fasteners and spacers and torque to specifications.

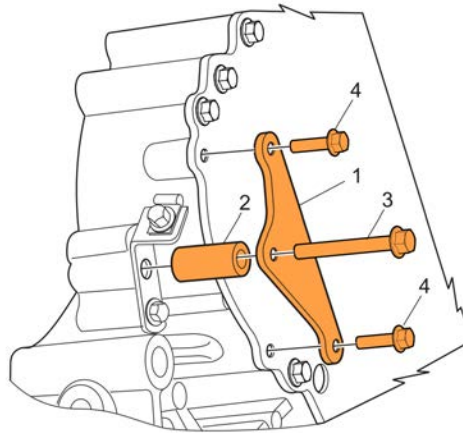

W4070253

Note: 3 possible installations, please refer to illustration for installation and part numbers.

Note: To be used on vehicles with AHI bracket.

Item Number	Description	Part Number
1	Bracket	21604236
2	Spacer	21604234
3	Flange Screw	975103
4	Flange Screw	946470

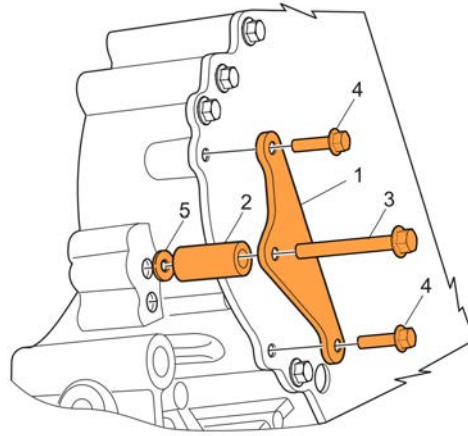

W4070538

Note: To be used on vehicles without AHI bracket.

Item Number	Description	Part Number
1	Bracket	21604236
2	Spacer	21604234
3	Flange Screw	975103
4	Flange Screw	946470
5	Washer	941744

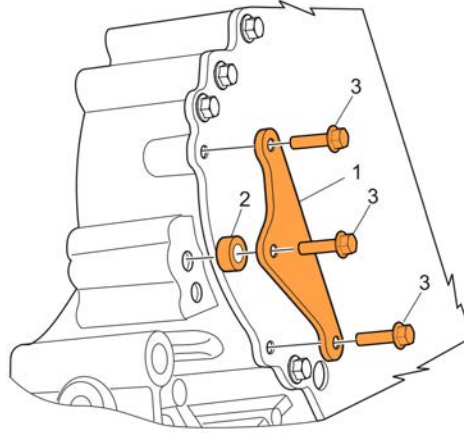

W4070537

Note: To be used on vehicles with mounting hole almost flush with top of flywheel housing.

Item Number	Description	Part Number
1	Bracket	21604236
2	Spacer	21604234
3	Flange Screw	975103

Note: M8 24 ± 4 Nm (18 ± 3 ft-lb)
M10 48 ± 8 Nm (35 ± 6 ft-lb)

- 15 Install the new gaskets and “V” clamps, torque to specifications.
Torque to: 20 ± 4 Nm (15 ± 3 ft-lb)

Note: Clean sealing surface on EGR valve and hot pipe.

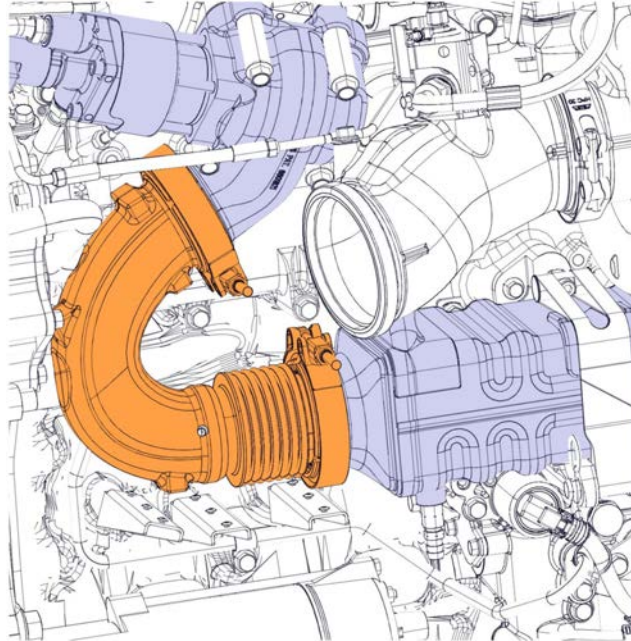

W2070267

- 16 Install EGR heatshield and secure (if equipped).
17 Install the AHI air lines at the cylinder head.

18 Install the new gaskets and “V” clamps, install the difusser between turbo and flex pipe torque to specifications.

Torques to: 12 ± 2 Nm (106 ± 18 in-lb)

Note: Clean sealing surface

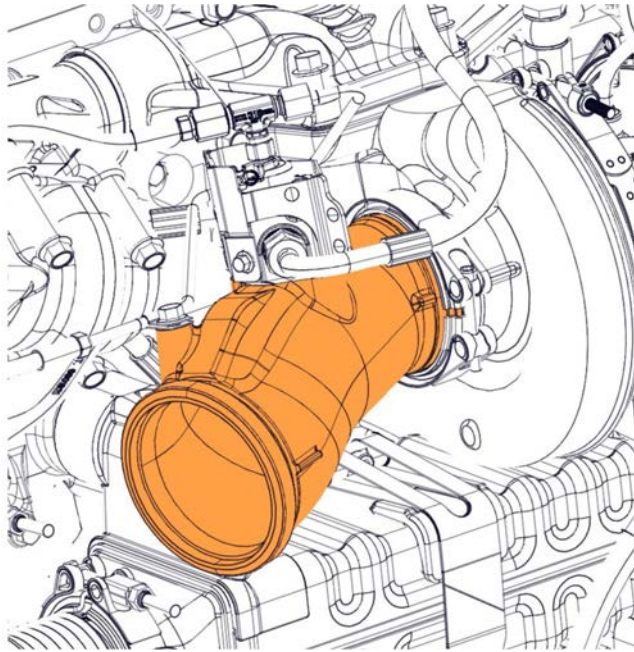

W2070257

19 Install the AHI harness into the original clamps on the valve cover.

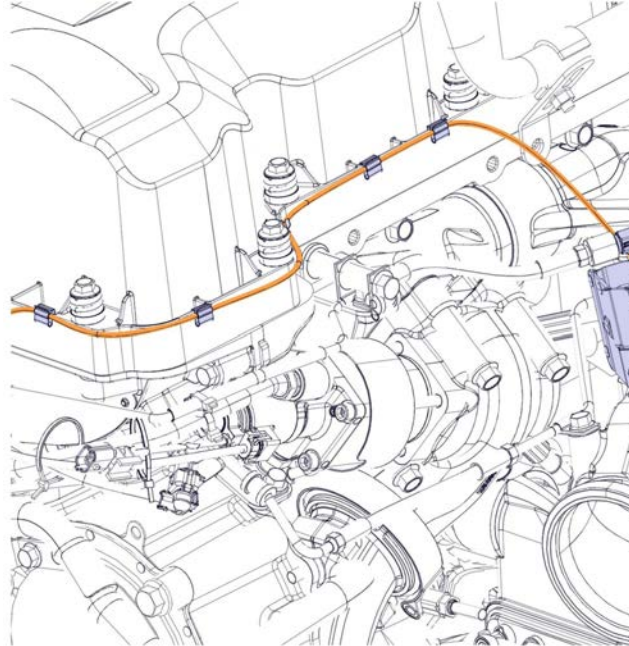

W4070265

20 Install the AHI – fuel and air line and torque to specifications.

Torque: Fuel Line 5 ± 0.5 Nm (135 ± 5 in-lb)

Air Line 27 Nm (235 in-lb)



W2070259

- 21 Install the AHI – coolant lines and torque to specifications.
Torque to: 48 ± 5 Nm (35 ± 4 ft-lb)

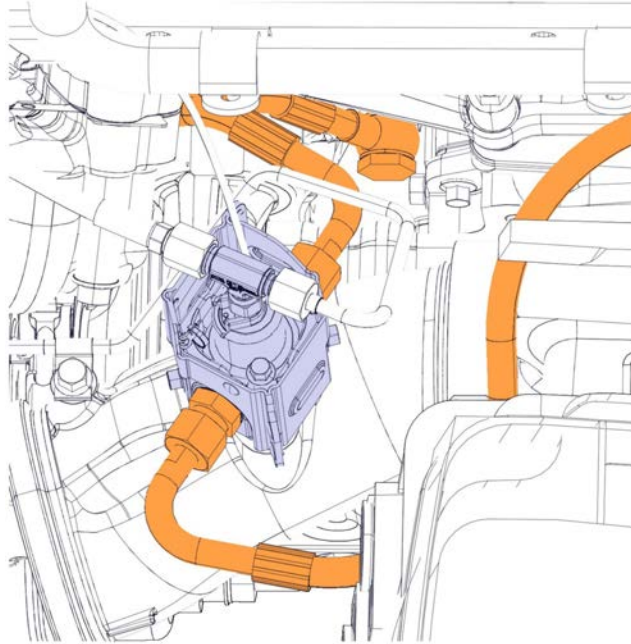

W2070258

22 Install the air filter housing and fresh air pipe.

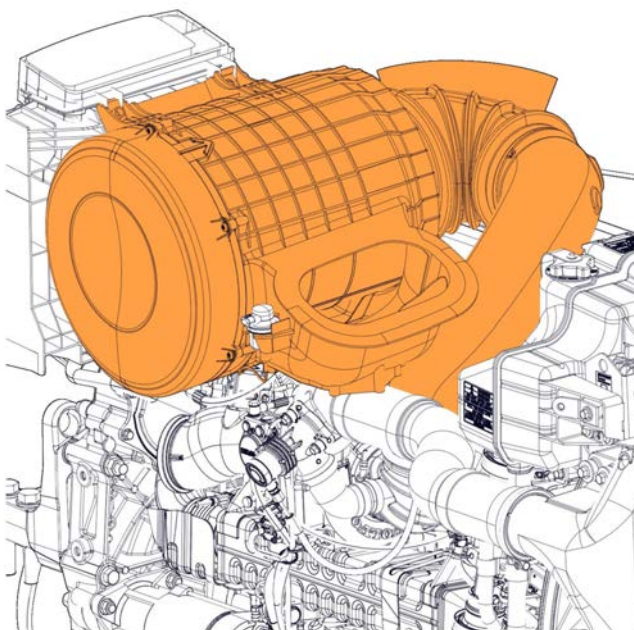

W2070256

- 23 Install engine coolant.
- 24 Install the right inner fender.
- 25 Install the right side fairing under passenger side door (if equipped).
- 26 Connect the battery cables.
- 27 Check exhaust for leaks.
- 28 Close and latch the hood.

Reimbursement

This repair may be eligible for reimbursement if a product failure was experienced within time and mileage limits of the applicable Warranty coverage. Reimbursement is obtained via the normal claim handling process.	
Claim Type (used only when uploading from the Dealer Bus. Sys.)	01
Labor Code	
Primary Labor Code	2113A-29-80 1.6 hrs.
Causal Part Short Housing	21063851
Causal Part Long Housing	21063847

Mack Trucks, Inc. engages in a comprehensive program of testing and evaluating to provide the best possible product. Mack Trucks, Inc. however, is not committed to, or liable for updating existing vehicles.