



Volvo Cars of North America, LLC

1 Volvo Drive
P.O. Box 914
Rockleigh, NJ 07647
Phone: 201-768-7300
www.volvocars.us

April 24, 2012

TO: ALL U.S. & CANADIAN VOLVO RETAILERS
RE: SERVICE CAMPAIGN 252

Volvo Cars of North America, LLC on behalf of Volvo Car Corporation, has decided to launch a service campaign on certain model year 2010-2012 S80, 2010 V70 and 2011-2012 S60, XC60 and XC70 vehicles.

Volvo has identified that the noise reduction cover on the Electric Hydraulic Power Assisted Steering (EHPAS) pump may absorb water and expose the pump housing to moisture. In corrosive areas over a long period of time (at least 5 years), the corrosion protection of the pump housing may deteriorate and negatively affect the operation of the power steering pump and or engine performance.

The corrective action is to replace the noise reduction cover on the EHPAS pump.

PLEASE NOTE: This Service Campaign will be in effect until November 30, 2014 regardless of mileage. Coverage is automatically transferred to subsequent owners.

OWNER NOTIFICATION

Owner notification is scheduled to begin in May. Volvo will contact the vehicle owners directly.

RETAILER RESPONSIBILITIES

Retailers must perform this Service Campaign on eligible vehicles regardless of miles/kilometers or vehicle age. All work performed under this Service Campaign is free of charge to the owner. In the event that a customer does not have a notification letter, the owner is not to be refused this work.

Your regional representative will follow up to ensure that this Service Campaign is proceeding smoothly.

A complete description of the Service Campaign requirements and claim submission procedures will follow.

It is the retailer's responsibility to review the details provided in the materials listed below with all involved personnel.

- Service Manager Bulletin
- Retailer Tech Journal
- Parts Bulletin

Your cooperation in completing this Service Campaign is greatly appreciated.

Drive Safely,
Volvo Cars of North America, LLC.

VOLVO				TITLE:		GROUP:	NO:	
				Service Campaign 252: Replace Power Steering Pump Cover		64	252	
Service Manager Bulletin						Model Year 2010 - 2012 S80, 2010 - V70, 2011 - 2012 S60, XC60 and XC70		ISSUING DEPARTMENT:
				Warranty				
Service Personnel: read and initial.				REFERENCE BULLETINS: TJ 26218, PB 64-252		CARMARKET:		
						United States and Canada		
SERVICE MANAGER		SERVICE WRITER		WARRANTY ADMINISTRATOR		DATE:		
						YEAR	MONTH	DAY
						2012	05	11
						Page 1 of 3		

- A. SERVICE CAMPAIGN 252 DESCRIPTION
- B. VEHICLES INVOLVED
- C. PARTS INFORMATION/PARTS RETURN
- D. OWNER NOTIFICATION
- E. VEHICLES IN RETAILER INVENTORY
- F. RETAILER RESPONSIBILITY
- G. CAMPAIGN REIMBURSEMENT PROCEDURES
- H. TECHNICIAN COMPETENCY REQUIREMENT
- I. RETAILER ALLOWANCE

A. SERVICE CAMPAIGN 252 DESCRIPTION

Volvo Cars of North America, LLC. on behalf of Volvo Car Corporation, has decided to launch a service campaign on certain model year 2010-2012 S80, 2010 V70 and 2011-2012 S60, XC60 and XC70 vehicles.

Volvo has identified that the noise reduction cover on the Electric Hydraulic Power Assisted Steering (EHPAS) pump may absorb water and expose the pump housing to moisture. In corrosive areas over a long period of time (at least 5 years), the corrosion protection of the pump housing may deteriorate and negatively affect the operation of the power steering pump and or engine performance.

The corrective action is to replace the noise reduction cover on the EHPAS pump.

Service Campaign 252 affects 13,819 vehicles in the U.S. and 2,381 vehicles in Canada.

PLEASE NOTE: This Service Campaign will be in effect until November 30, 2014 regardless of mileage. Coverage is automatically transferred to subsequent owners.

B. VEHICLES INVOLVED

NOTE: RETAILER MUST CONFIRM VEHICLE ELIGIBILITY PRIOR TO BEGINNING REPAIR FOR THIS SERVICE CAMPAIGN.

"Fixed Right — First Time"



Vehicle eligibility must be confirmed:

- Inquire in VRC² - Vehicle Warranty where the message "SERVICE CAMPAIGN 252 Replace EHPAS Pump (S69285) SMB 64-252" will appear for eligible vehicles.

All vehicles should be checked for any other incomplete recalls or service campaigns or service upgrades. All open Recall, Service Campaign or Service Action repairs should be completed.

RETAILER VEHICLE CAMPAIGN LIST

A "Retailer Campaign List" will be posted on VRC² in the Reports Menu under the Service Tab. This list details all affected vehicles that are on record as being retailed or currently in stock at your facility, and is updated monthly. Vehicle eligibility must be confirmed via VRC² prior to performing this service campaign.

C. PARTS INFORMATION / PARTS RETURN

Please refer to Parts Bulletin 64-252.

PARTS RETURN

Parts are not required to be returned for repairs done in accordance with this service campaign.

D. OWNER NOTIFICATION

Vehicle owners will be contacted directly by Volvo in the U.S. and Canada.

E. VEHICLES IN RETAILER INVENTORY

All vehicles in retailer inventory and qualifying for this service campaign should be repaired prior to a customer taking possession of the vehicle.

F. RETAILER RESPONSIBILITY

Retailers are to perform this service campaign on eligible vehicles regardless of mileage/kilometers or vehicle age. The campaign work covered under Service Campaign 252 is free of charge to the owner. If a customer presents a recall or service campaign letter for a vehicle that is not found via the VRC² inquiry function, please verify that the letter applies to the customer's vehicle and call the Warranty Assistance Desk at 1-800-807-7712 for instructions. If the Warranty Assistance Desk verifies that the vehicle qualifies for the Recall or Service Campaign, please perform the repair and place the recall or service campaign letter in the customer's file. Under no circumstances should a customer be denied the required service without a confirmation from VCNA/VCCL.

G. CAMPAIGN REIMBURSEMENT PROCEDURES

Service Campaigns 252 claims should be submitted using the LONG FORM application only.

H. TECHNICIAN COMPETENCY REQUIREMENT

The technician competency requirement for this campaign repair is: Level 2 Certified Tech.

I. RETAILER ALLOWANCE (LONG FORM APPLICATION)

Labor reimbursement is effective at time of release and may change in the future.

Claim Type: S69285
Cause Code: 02
CSC Code: XW
Main OP: 64795
Failed Part: 31360689

<u>Operation Number</u>	<u>Repair Description</u>	<u>Qty</u>	<u>Labor Time</u>
64795	Replace EHPAS Pump Cover	1	1.2 Hrs
64796	Replace EHPAS Pump Bushings If necessary	1	0.1 Hrs

Title Service Campaign 252, Power Steering Pump Cover
Ref No US26218.1.1 en-US
Issuer -
Partner 3 US 7510 Volvo Cars North America
Func Group 6400
Func Desc steering

Status Released
Status Date 2012-04-24
Issue Date 2012-04-19
Reference

Attachment

File Name	File Size
Service_Campaign_252.pdf	2.0755 MB

Vehicle Type

Type	Eng	Eng Desc	Sales	Body	Gear	Steer	Model Year	Plant	Chassis range	Struc Week Range
124							2010-2012		0134001-0143501	0-0
134							2011-2012		0000003-0021153	0-0
135							2010-2010		0167001-0191999	0-0
136							2011-2012		0094002-0104947	0-0
156							2011-2012		0135066-0176900	0-0

CSC Customer Symptom Codes

Code	Description
XW	Service action/Recall/Service action/Recall

DTC Diagnostic Trouble Codes

Text

Volvo Cars of North America, LLC. has decided to launch a service campaign on certain model year 2010-2012 S80 & V70, 2011 XC60 and 2011-2012 S60 and XC70 vehicles.

Volvo has identified that the noise reduction casing on the Electric Hydraulic Power Assisted Steering (EHPAS) pump, may absorb water and expose the pump housing to moisture. In corrosive areas over a long period of time (at least 5 years), the corrosion protection of the pump housing may deteriorate and negatively affect the operation of the power steering pump and or engine performance.

The corrective action is to replace the noise reduction cover on the EHPAS pump.

EHPAS = Electronic Hydraulic Power Assisted Steering

To view TJ attachment continue to next page:



Volvo Car Customer Service

Title	Power steering pump cover	Page	1(10)
Action	Service Campaign 252	Operation number:	64795-2 64796-3

Affected vehicles

Year	Model	Engine
2011, 2012	S60 (11-)	B6304T4
2010, 2011, 2012	S80 (07-)	B6304T4 B6324S4, S5
2010	V70 (08-)	B6304T4
2011, 2012	XC60	B6304T4 B6324S4, S5
2011, 2012	XC70 (08-	B6304T4 B6324S4, S5

Materials

Materials	Qty.	Part No.	Notes
Cover	1.0	31360689	
Rubber bushing, set of 4	1.0	31317220	

Special tools

Description	Part No.
Tensioner band	999 5682

Removal

Remove right front wheel, refer to:
Removal, replacement and installation
7 - Springs and wheels
77 - Wheels, tires, hubs
771 - Wheel and wheel trim

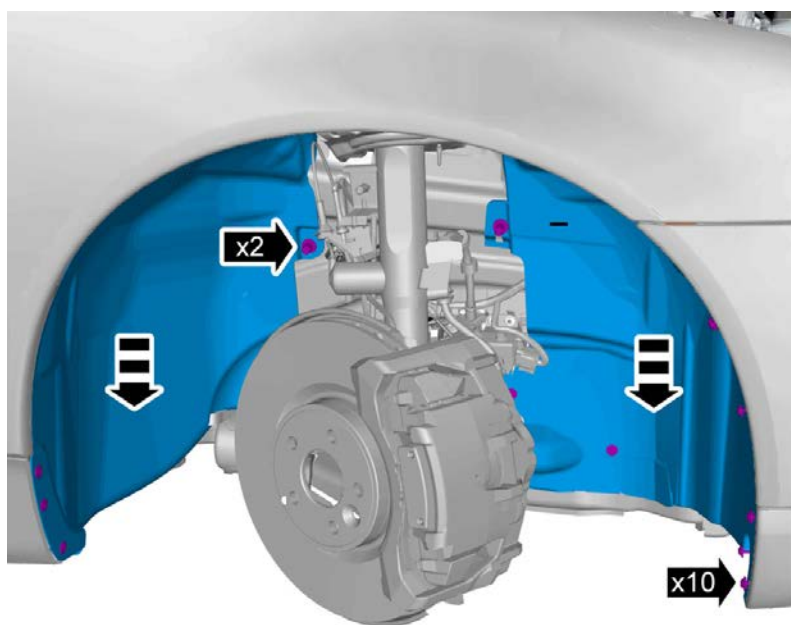

Remove the inner wheel housing as shown.

Detach right-hand side bumper, refer to:
Removal, replacement and installation
8 - Body and interior
86 - Bumpers and mudflaps
861 - bumper with suspension and damping

Hold the bumper cover using Tool 9995682 or similar.

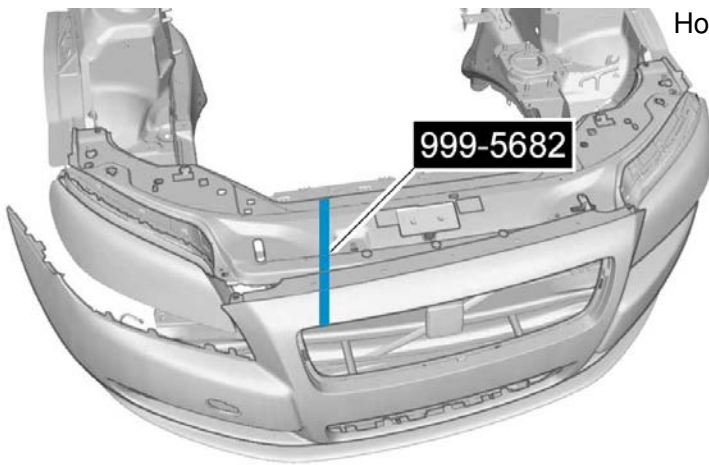

Be prepared to collect escaping fluid.

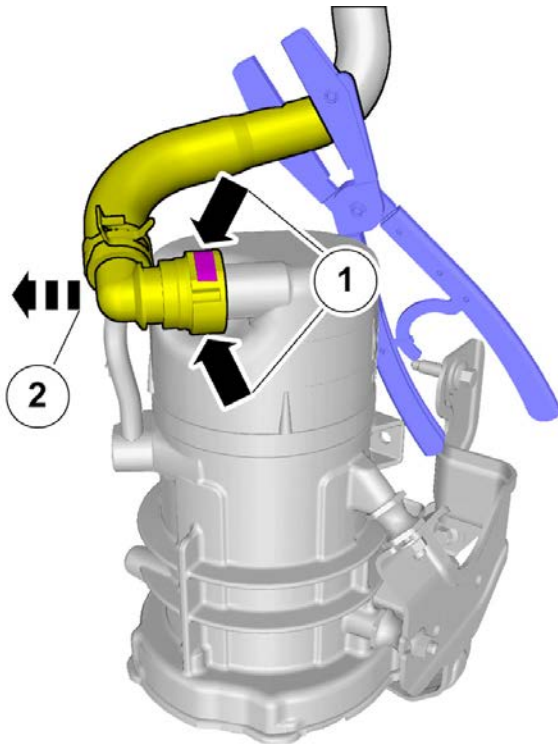

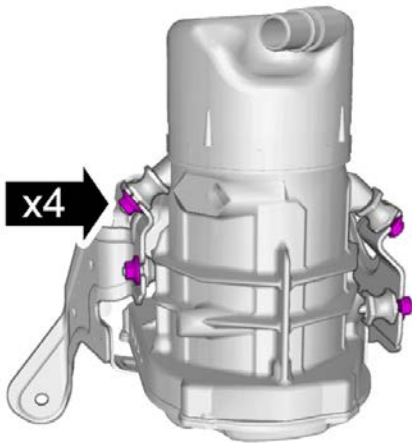

Remove the 4 M6 nuts.
Torque to 10Nm when reinstalling.

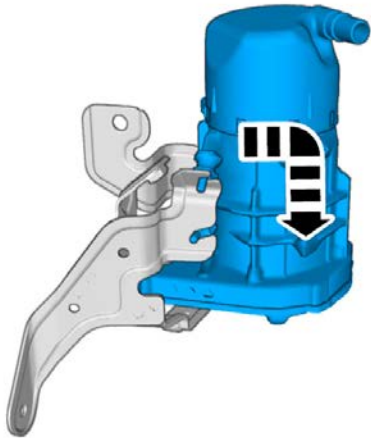

Lower the unit from its mounting bracket.

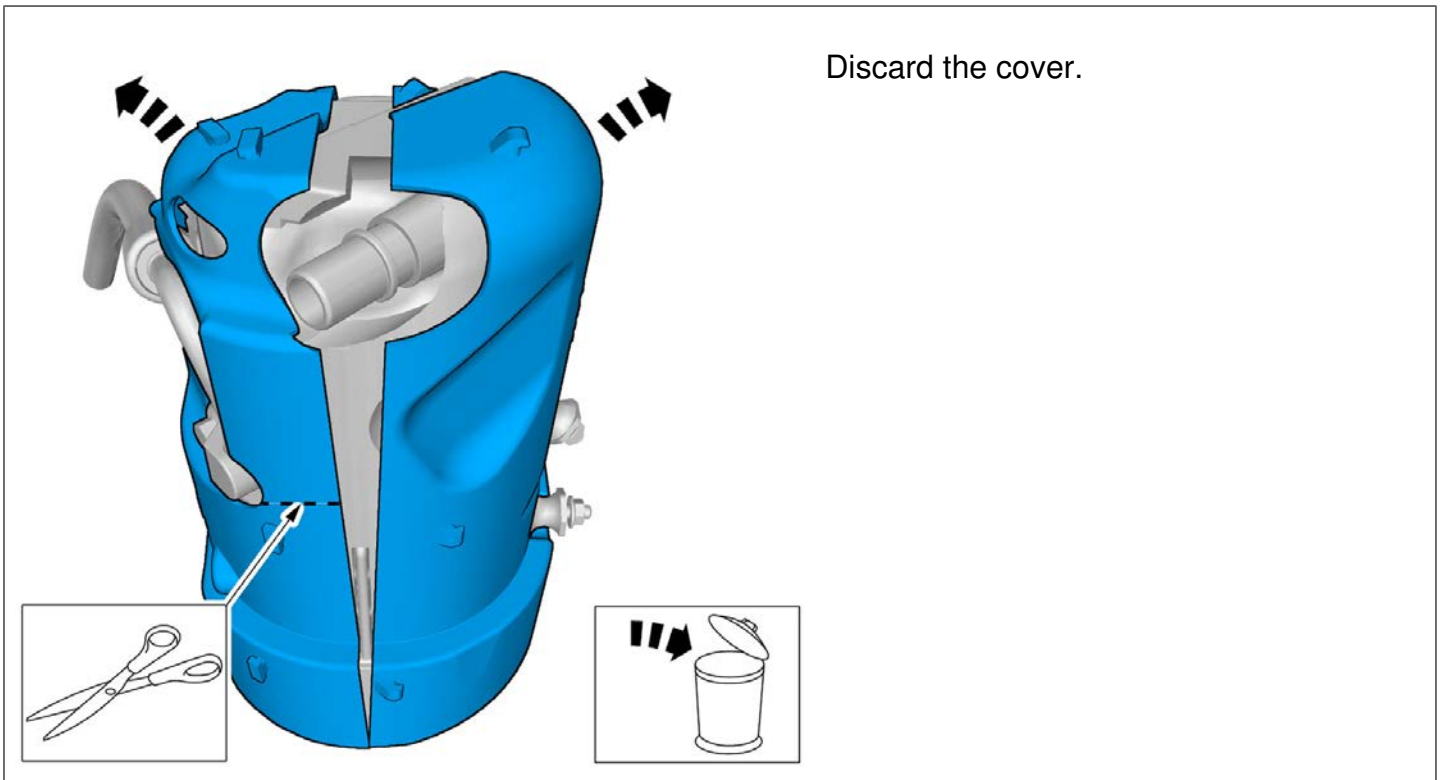
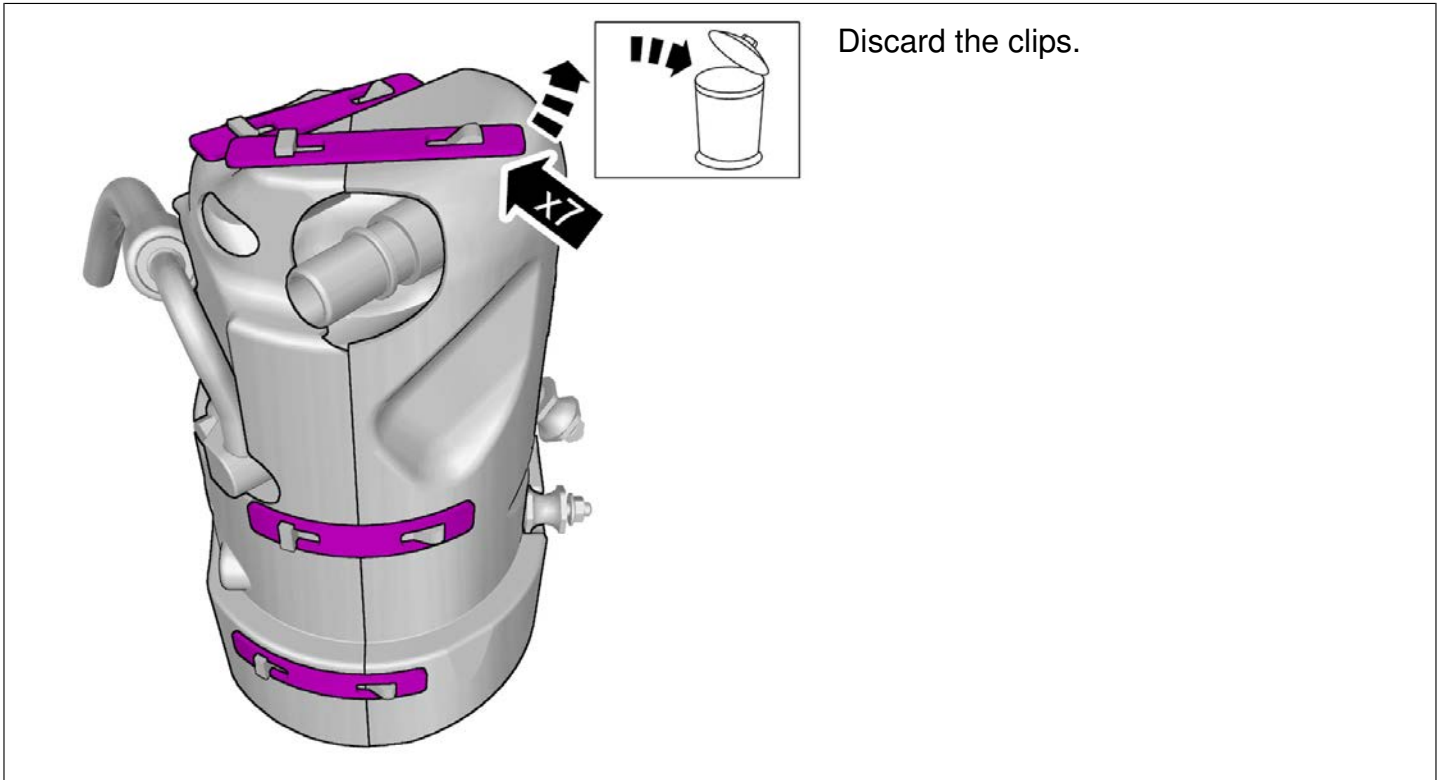

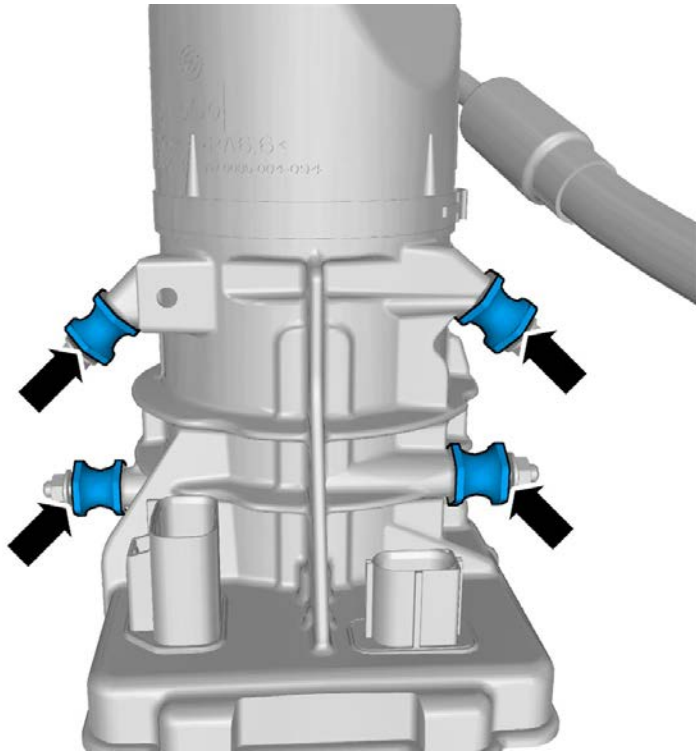

Check the condition of the rubber bushings.
Replace them if damaged.

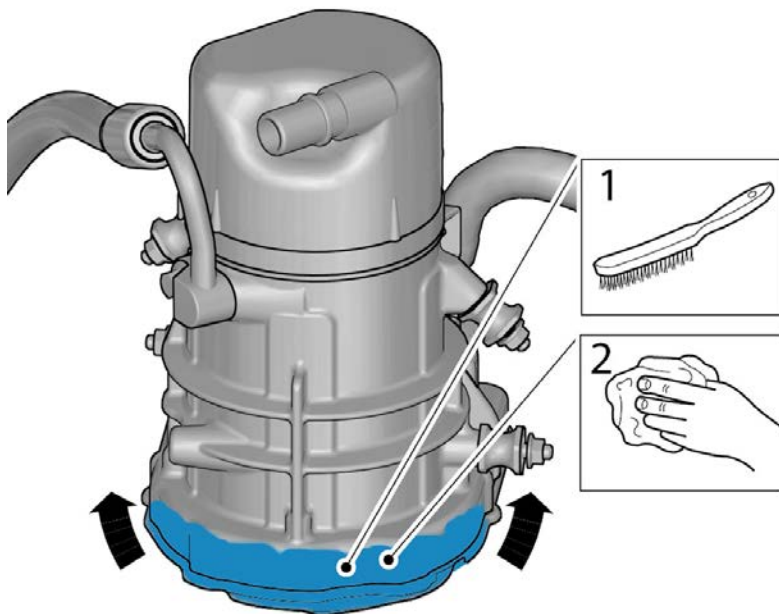

Make sure that the surface indicated is clean and free
of corrosion or other foreign material.

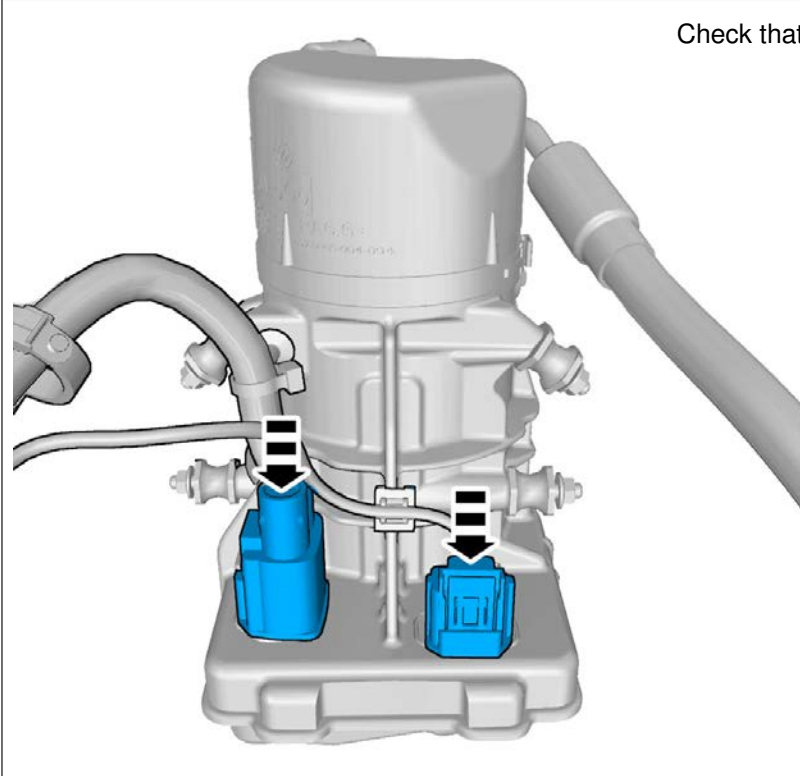

Check that the electrical connectors are properly connected.

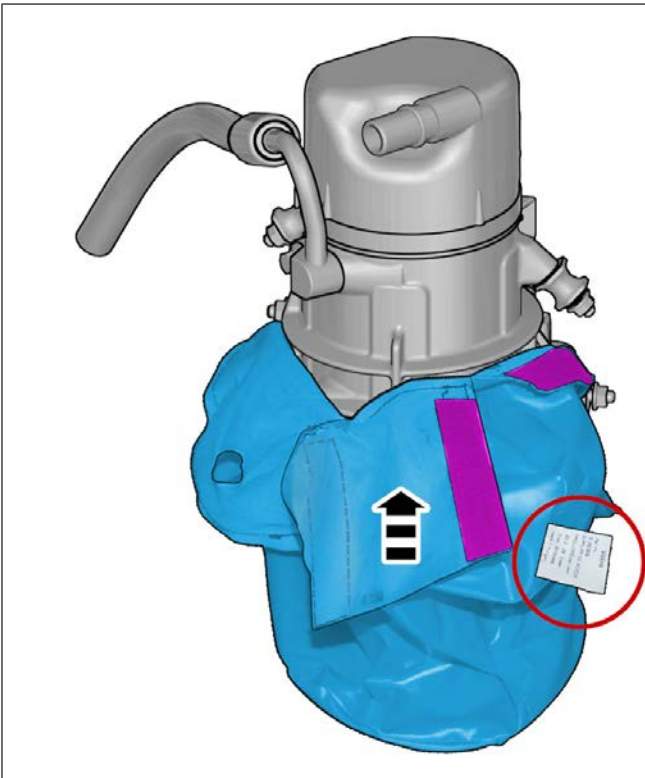

Begin installing the cover.
Note the position of the tag.



Continue installing the cover.
Push the holes in the cover over
the mounts so that the cover sits
in the middle of the rubber mounts
as shown.

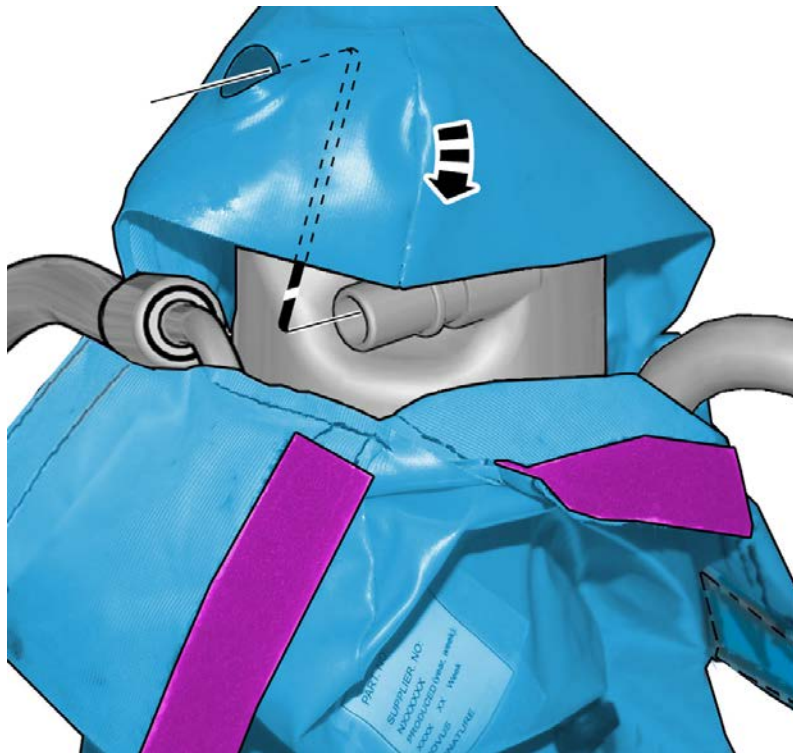

Install the top of the cover over the
unit as shown.

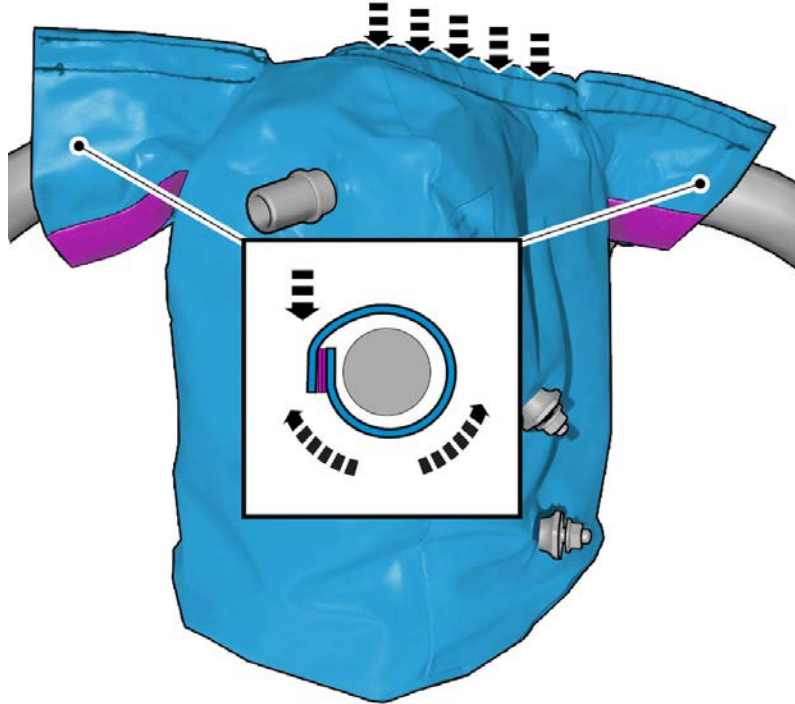

Continue installing the cover.
Wrap it over the wiring harness
and oil line as shown.

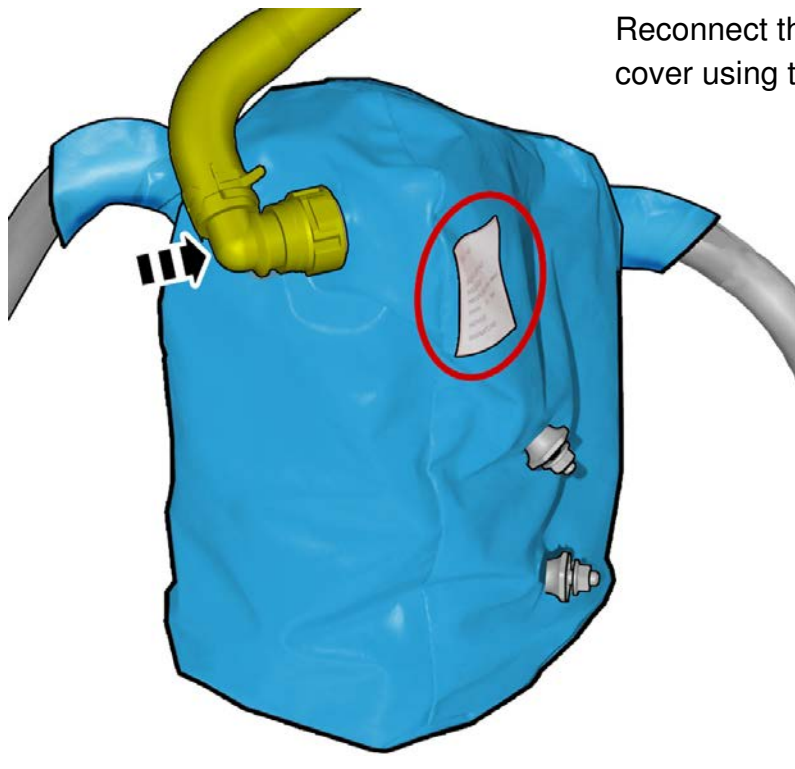

Reconnect the oil line and confirm the positioning of the
cover using the tag.

Installation

To install, reverse the removal procedure.

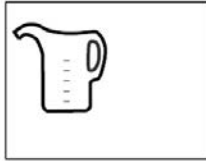

Make sure that fluid level is to the MAX mark.
Use power steering fluid, 30741424 as needed,
not eligible for reimbursement.



Parts Bulletin

SUBJECT Service Campaign 252: Replace Power Steering Pump Cover				GROUP 64		NO 252	
				MARKET United States, Canada		PAGE 1 of 1	
COPY TO / CIRCULATIONS (PLEASE INITIAL)							
GENERAL MGR	PARTS MGR	SERVICE MGR	SALES MGR	DATE	YEAR	MONTH	DAY
					2012	04	24

Reference Bulletins: SMB 64-252
TJ26218

Volvo Cars of North America, LLC. has decided to launch a service campaign on certain model year 2010-2012 S80, 2010 V70 and 2011-2012 S60, XC60 and XC70 vehicles.

Volvo has identified that the noise reduction casing on the Electric Hydraulic Power Assisted Steering (EHPAS) pump, may absorb water and expose the pump housing to moisture. In corrosive areas over a long period of time (at least 5 years), the corrosion protection of the pump housing may deteriorate and negatively affect the operation of the power steering pump and or engine performance.

The corrective action is to replace the noise reduction casing on the EHPAS pump.

PLEASE NOTE: This Service Campaign will be in effect until November 30, 2014 regardless of mileage. Coverage is automatically transferred to subsequent owners.

The following part numbers apply:

Part Number	Description	Qty
31360689	Casing	1
31317220	Rubber bushing	1

Service Campaign 252 affects 13,819 vehicles in the U.S. and 2,381 vehicles in Canada.

"Fixed Right — First Time"





Volvo Cars of North America, LLC

1 Volvo Drive
P.O. Box 914
Rockleigh, NJ 07647
Phone: 201-768-7300
www.volvocars.us

IMPORTANT SERVICE CAMPAIGN NOTICE

April 30, 2012

Dear Volvo Owner:

Your satisfaction with your Volvo and the Volvo organization are very important to us. We are committed to ongoing product improvements and methods; therefore we have launched Service Campaign 252.

The Reason for Service Campaign 252:

Volvo Cars of North America, LLC on behalf of Volvo Car Corporation, has decided to launch a service campaign on certain model year 2010-2012 S80, 2010 V70 and 2011-2012 S60, XC60 and XC70 vehicles.

Volvo has identified that the noise reduction cover on the Electric Hydraulic Power Assisted Steering (EHPAS) pump may absorb water and expose the pump housing to moisture. In corrosive areas over a long period of time (at least 5 years), the corrosion protection of the pump housing may deteriorate and negatively affect the operation of the power steering pump and or engine performance.

The corrective action is to replace the noise reduction cover on the EHPAS pump.

What you should do:

This procedure will be completed at no cost and can take up to two hours to complete; however, due to service scheduling and parts availability, the time your Volvo retailer requires to service your vehicle may vary.

PLEASE NOTE: This Service Campaign will be in effect until November 30, 2014 regardless of mileage. Coverage is automatically transferred to the subsequent owner.

Please contact:

If you have any questions, please contact your Volvo retailer. If your retailer is unable to answer your questions; please contact Volvo Customer Care Center at 1 Volvo Drive, Rockleigh, NJ 07647 or phone 1-800-458-1552, Monday through Friday, 8:30 A.M. to 5:00 P.M. Eastern Time. You may also e-mail us at customercare@volvoforlife.com.

We sincerely apologize for any inconvenience this action may cause you, but we trust you will appreciate our efforts to continually safeguard the quality and safety associated with our products.

Sincerely,

A handwritten signature in cursive script that reads "Mike Assainte".

Mike Assainte
Manager, Customer Support