

Applies To: **2012 Civic 4-Door – ALL****March 20, 2012**

## Driver's and Front Passenger's Doors Do Not Unlock in Freezing Weather

### SYMPTOM

In freezing weather, the driver's and front passenger's doors don't unlock with the remote or the key.

### PROBABLE CAUSE

Moisture in the lock cable freezes.

### CORRECTIVE ACTION

Dry and lubricate the lock cable.

### REQUIRED MATERIALS

Dow Corning 111 Valve Lubricant & Sealant  
(commercially available)

### WARRANTY CLAIM INFORMATION

The normal warranty applies.

OP#	Description	FRT
8180A2	Dry and lubricate the lock cable on one front door	0.4
A	Add for the other front door	0.4

Failed Part: P/N 72133-TR0-A01

Defect Code: 03214

Symptom Code: 07902

Skill Level: Repair Technician

### REPAIR PROCEDURE

1. Remove the power window switch panel from the affected door by pulling it upward and forward in the sequence shown, then disconnect the connectors.

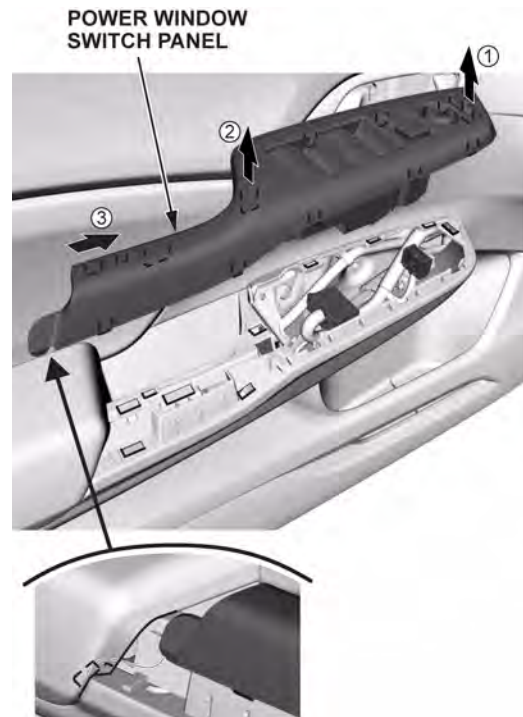

2. Push in the tab, then remove the inner handle cap.

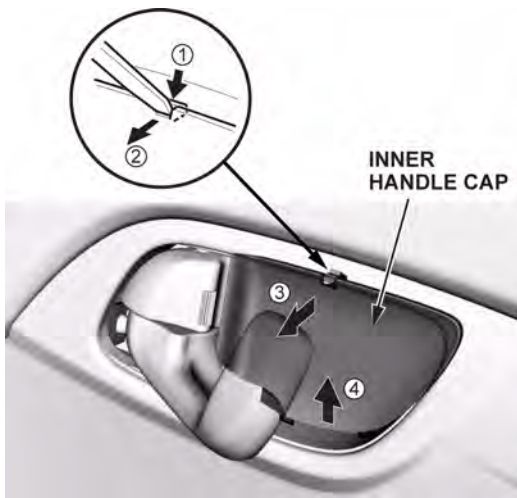

3. Remove the screw, then pull the inner door handle out of the door panel.

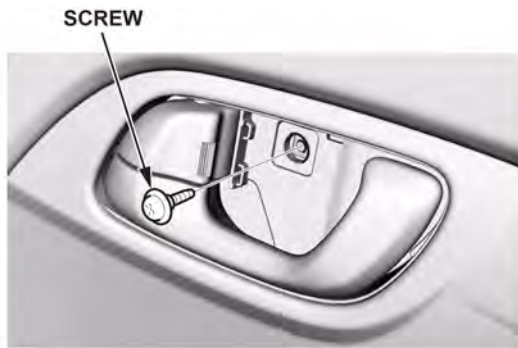

4. Remove the screw under the door handle.

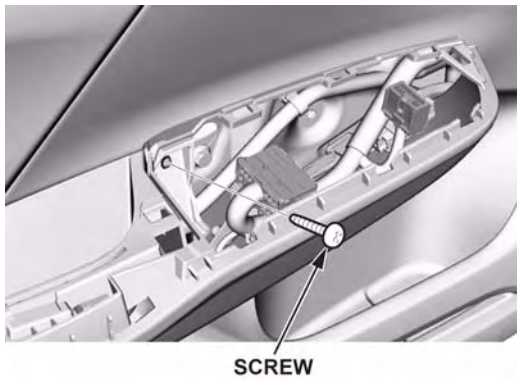

5. Carefully release the eight clips holding the door panel in place, and remove the panel by pulling upward.

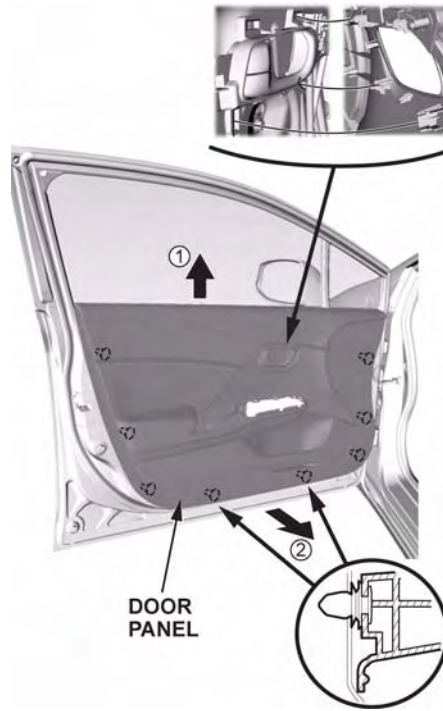

6. Remove any moisture from the lock cable by blowing compressed air into the cable end at the inner handle.



Blow are here.

7. Remove the door latch.
8. Clean the cable surface, and remove any potential traces of oxidation with a clean, dry towel.

Clean area with shop towel.



9. Apply DC 111 lubricant to the lock cable as shown.



10. Reinstall the door latch.
11. Reinstall the door panel.
12. Reattach the screw under the door handle.
13. Reinstall the door handle and the inner handle cap.
14. Reinstall the power window switch panel.