

 Applies To: **2009–11 TSX – ALL**
January 12, 2012

Windshield Side Trim Retainer Is Loose or Missing (Supersedes 09-016, dated October 14, 2010; see REVISION SUMMARY)

REVISION SUMMARY

This service bulletin was revised extensively; American Honda recommends that you review all sections thoroughly.

CORRECTIVE ACTION

Remove both windshield side trim pieces, and replace any retainers that are loose or missing. Then, reinstall or, if necessary, replace the trim pieces.

PARTS INFORMATION

Windshield Side Trim Retainer A:
P/N 91573-TL2-305

Windshield Side Trim Retainer B:
P/N 91574-TL2-305

Plastic Slide Clip, Left: P/N 73163-TL0-E01

Plastic Slide Clip, Right: P/N 73153-TL0-E01

Right Side Trim Kit:

(Includes windshield side trim, three windshield side trim retainers A, and one windshield side trim retainer B)

P/N 73152-TL2-305ZA (B-538M)
P/N 73152-TL2-305ZB (B-553P)
P/N 73152-TL2-305ZC (NH-624P)
P/N 73152-TL2-305ZD (NH-731P)
P/N 73152-TL2-305ZE (NH-736M)
P/N 73152-TL2-305ZF (NH-737M)
P/N 73152-TL2-305ZG (NH-743M)
P/N 73152-TL2-305ZH (R-530P)

Left Side Trim Kit:

(Includes windshield side trim, three windshield side trim retainers A, and one windshield side trim retainer B)

P/N 73162-TL2-305ZA (B-538M)
P/N 73162-TL2-305ZB (B-553P)
P/N 73162-TL2-305ZC (NH-624P)
P/N 73162-TL2-305ZD (NH-731P)
P/N 73162-TL2-305ZE (NH-736M)
P/N 73162-TL2-305ZF (NH-737M)
P/N 73162-TL2-305ZG (NH-743M)
P/N 73162-TL2-305ZH (R-530P)

REQUIRED MATERIALS

Konishi Bond SL211B: P/N 08713-0008
(one tube repairs about two vehicles)

WARRANTY CLAIM INFORMATION

The normal warranty applies.

OP#	Description	FRT
8310A5	Remove and reinstall or replace both windshield side trim pieces.	0.4
A	Add for replacing one or two retainers.	0.1
B	Add for replacing three or four retainers.	0.2
C	Add for replacing five or six retainers.	0.3
D	Add for replacing seven or eight retainers.	0.4

Failed Part: P/N 91573-TL0-E01

Defect Code: 06201

Symptom Code: 06101

Skill Level: Repair Technician

REPAIR PROCEDURE

NOTE:

- The bridges on the windshield side trim may break when removing the trim.
- Make sure not to break the bottom clip retainer tabs so the trim can be reused.
- Allow the adhesive to cure for a minimum of 24 hours before removing the tape from the vehicle.
- Advise the client not to wash the vehicle for at least 24 hours.

- Starting at the top, work your way down to remove the windshield side trim from the retainers using the appropriate KTC trim tool.

NOTE: Make sure you do not damage the rubber seal on the windshield side trim.



- Slide the trim up to release it from the bottom clip.

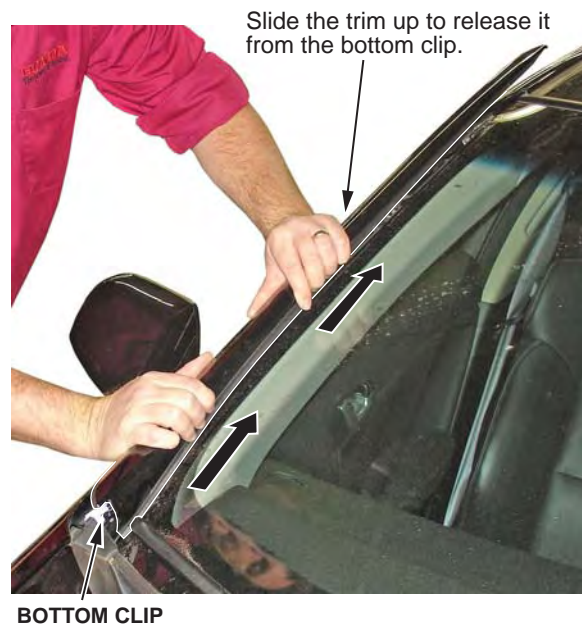

- Inspect the bottom clip retainer tabs on the windshield side trim.
 - If the bottom clip retainer tabs are broken or stress whitened, discard the trim and use a new windshield side trim to complete the repair, then go to step 9.
 - If the bottom clip retainer tabs are OK, go to step 4.

NOTE: The new windshield side trim comes with new retainers and a bottom plastic clip.



- Inspect the trim for retainers. If any retainers are attached, bend the tabs out to remove them from the trim.

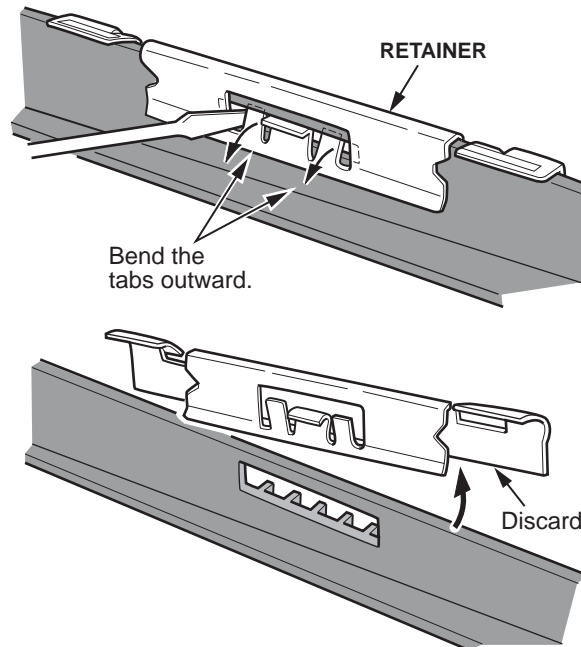

5. Inspect the windshield side trim for broken or cracked bridges. If a bridge is broken or cracked, use diagonal cutters and trim it as shown.

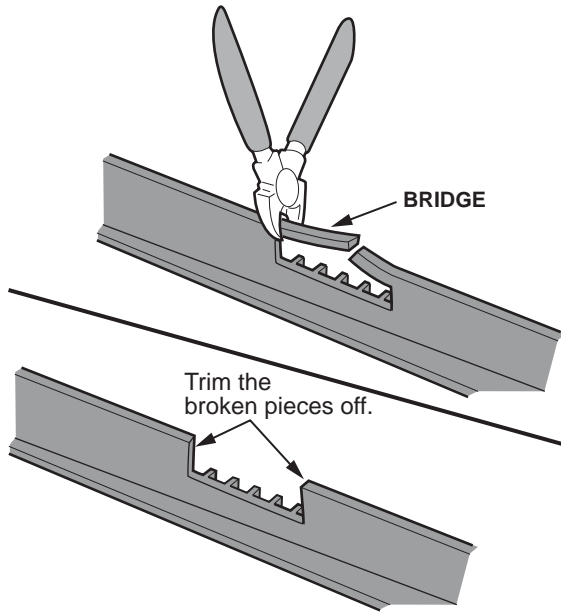

6. Remove the plastic bottom clip on the vehicle by turning it 90 degrees. If the bottom clip is damaged or stress-whitened, replace it.

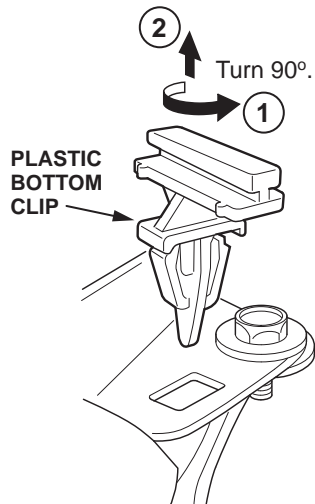

7. Reinstall the plastic bottom clip onto the windshield side trim. Make sure the projection on the clip points up.

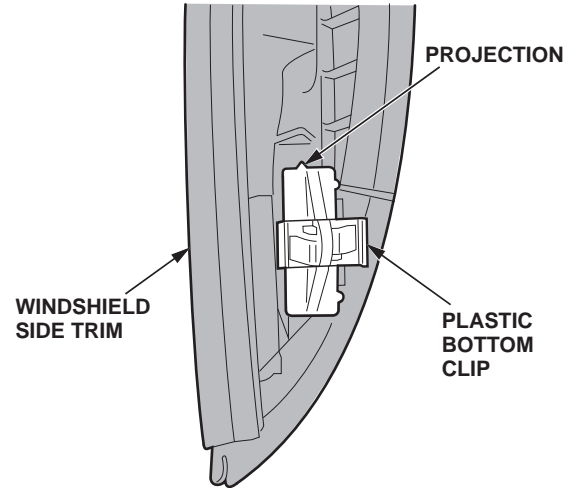

8. Clean the trim with a shop towel dampened with 3M general purpose cleaner or isopropyl alcohol. Keep oil, grease, and water from getting on the bonding surface.
9. Inspect the retainers on the vehicle:
 - If any retainers are missing or loose, go to step 11.
 - If any retainers are firmly attached to the A-pillar, remove any plastic trim pieces from them with a flat-tip screwdriver. Go to step 10.

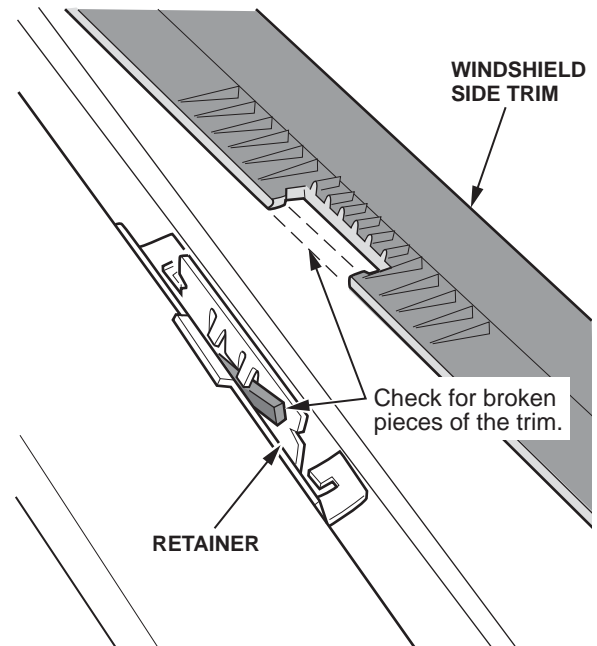

10. Bend the tabs on the retainers back into place as shown.

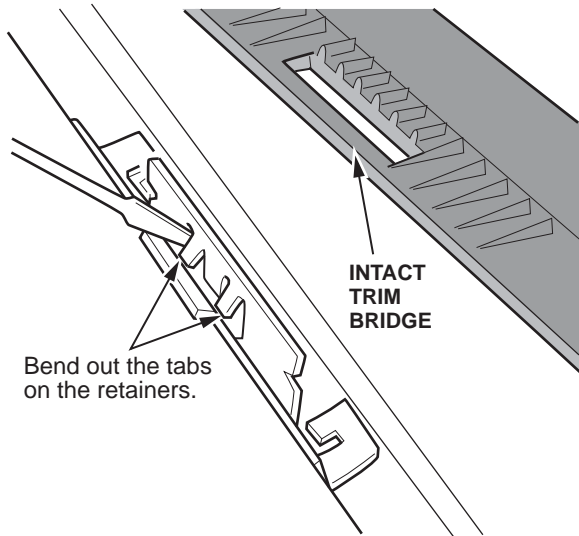

11. Remove any loose retainers or adhesive from the body:

- Using a heat gun, heat the retainer or adhesive to 212°–248°F (100°–120°C). Avoid damaging the paint by applying heat gradually.
- Use a plastic scraper to remove the loose retainer or glue from the body.
- Be careful not to scratch the body.
- While applying heat, use the plastic scraper to remove any double-sided tape that may be stuck to the A-pillar.

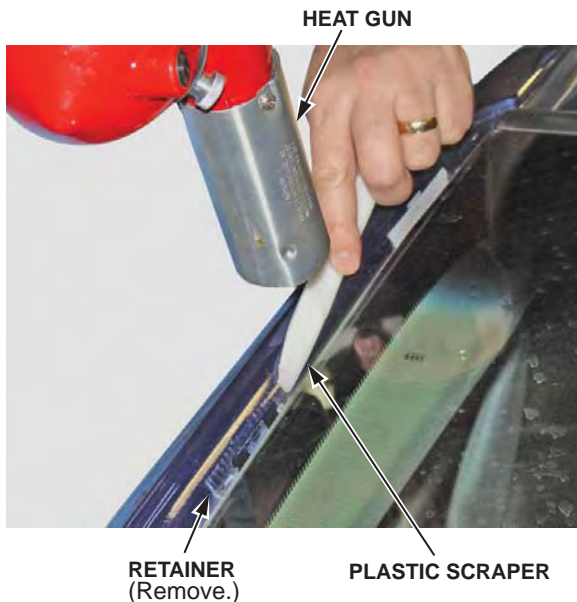

12. Clean the bonding surface on the body with a shop towel dampened with 3M General Purpose Adhesive Cleaner or isopropyl alcohol. After cleaning, keep oil, grease, and water from getting on the bonding surface.

13. Cut the Konishi Bond applicator tip to a diameter of 6 mm.

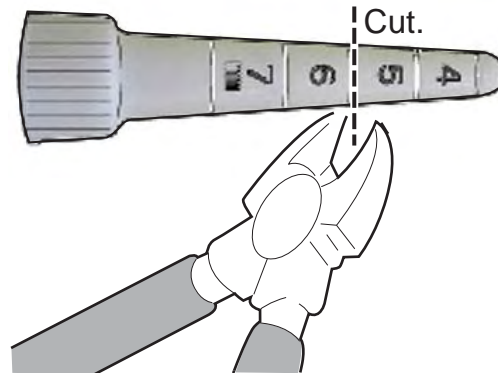

14. Apply a thin layer of Konishi Bond to the entire bonding surface on each new retainer as shown.

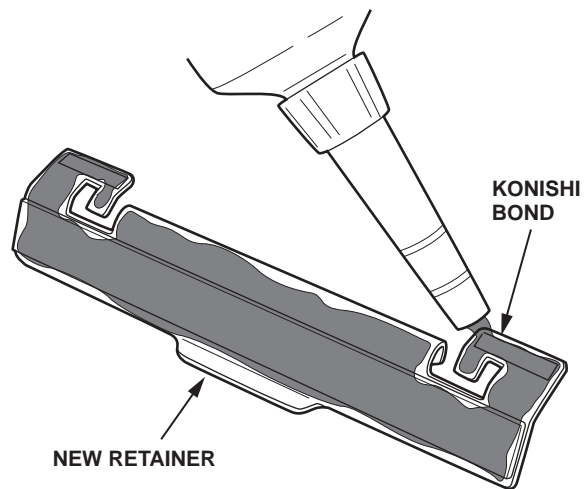

15. Install the new retainers in the locations where the original retainers were removed, and allow the Konishi Bond to cure for 15 minutes before going to the next step.

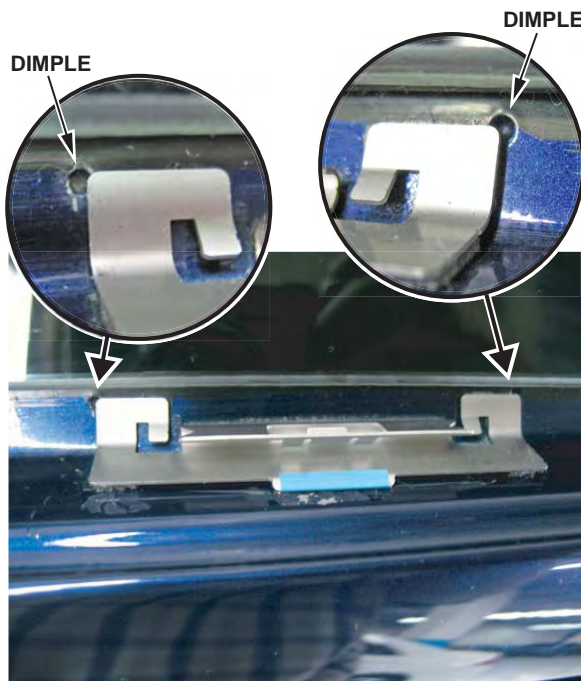

16. As a guide, lay the windshield side trim down next to the retainers before applying the Konishi Bond.

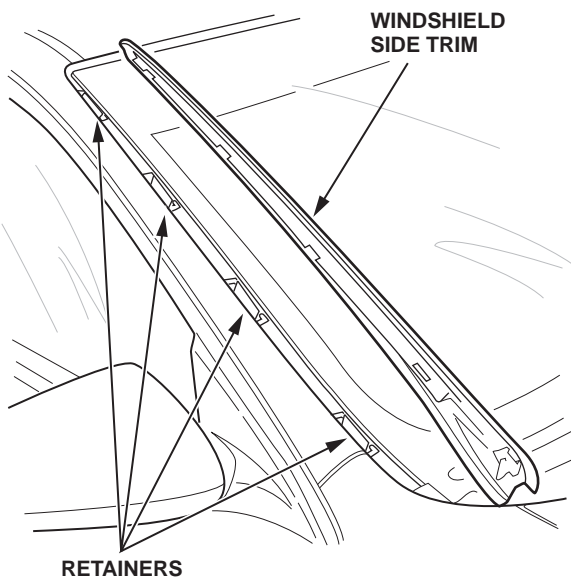

17. Starting at the bottom, apply a bead of Konishi Bond between each retainer, and into any retainer where the windshield side trim bridge location was cut out. Make sure the bead is at least 5 mm high.

NOTE: Konishi Bond adhesive begins curing with exposure to moisture in the atmosphere. Do step 18 immediately after applying the adhesive.

Do not apply Konishi Bond into any retainer where the bridge is still intact on the windshield side trim.

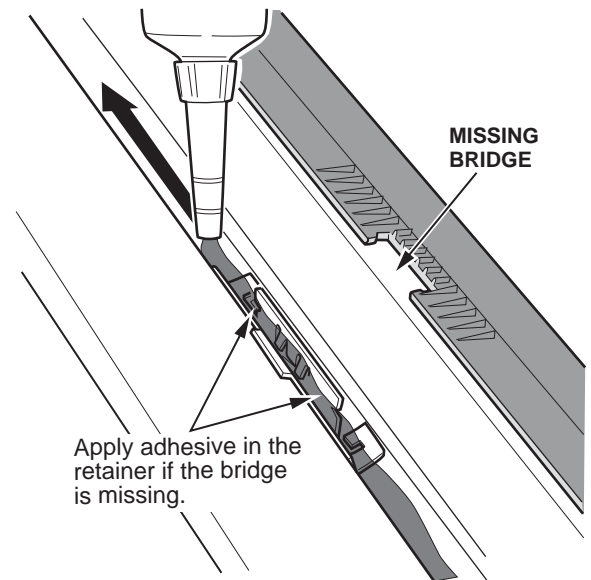
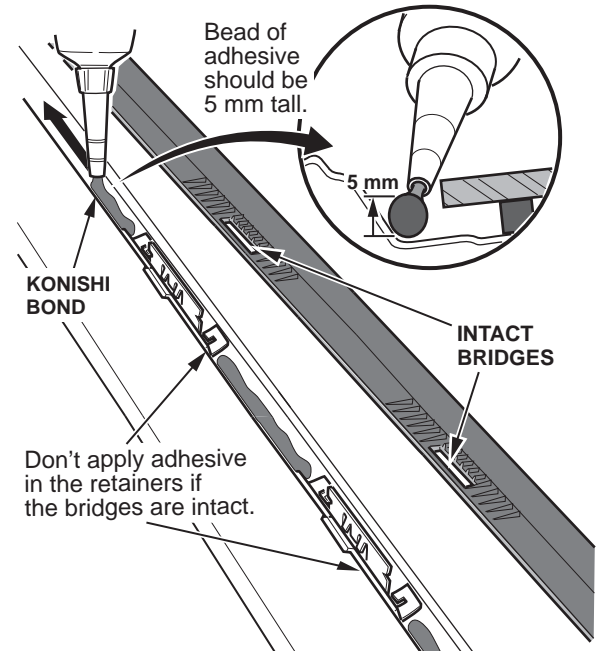

18. Starting at the top, position the windshield side trim to align the top retainer between the trim alignment ribs. Firmly press the trim into the retainers and bottom clip hole until they click into place.

NOTE:

- The trim will click into place only where the bridge on the trim is intact.
- If you don't confirm that the windshield side trim has clicked into place, you may get a comeback.

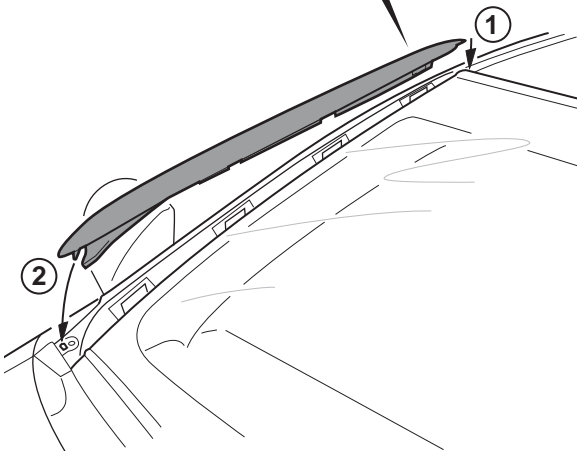
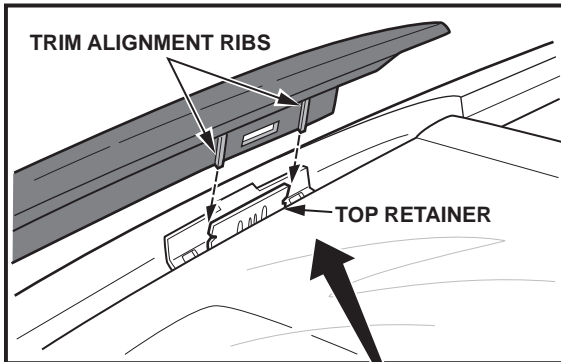

Use your elbow and leverage your body weight to set stubborn clips,



19. Secure the trim with low-tack masking tape as shown.



20. Repeat steps 1 thru 19 on the other side.

NOTE:

- Allow the adhesive to cure a minimum of 24 hours before removing the tape from the vehicle.
- Advise the client not to wash the vehicle for at least 24 hours.
- To prevent the remaining Konishi Bond adhesive from curing in the tube, squeeze the tube from the bottom to remove any air before replacing the cap.