

Description of Revisions: *This bulletin replaces the version dated June 2011. The use of channel locks is now advised if the technician does not have a star gauge removal tool (p/n 87340-4404). The gauge removal tool is no longer available at the PDC.*

General Information

The fuel level gauge introduced with the EPA 2010 engines may intermittently drop to empty. The gauge will remain at empty for approximately 25 miles (40 KM) then return to normal. This inaccuracy is due to the gauge picking up incorrect information over the proprietary J1587 databus.

To resolve this problem, a new fuel gauge has been introduced.

Parts

Parts are available through the PDCs. See [Table 1](#) for fuel level gauge parts.

Fuel Level Gauge Parts		
Part	Original Fuel Gauge Part Number	Replacement Fuel Gauge Part Number
Gauge-Fuel, DEF, 2010, Black	A22-65831-000	A22-69320-000
Gauge-Fuel, DEF, 2010, Gold	A22-65831-001	A22-69320-001
Gauge-Fuel, DEF, 2010, Bright	A22-65831-002	A22-69320-002

Table 1, Fuel Level Gauge Parts

Gauge Replacement

1. Apply the parking brakes and chock the tires.
2. Open the main instrument dash panel by removing the four fasteners. See [Fig. 1](#). Tip the instrument panel forward to access the rear of the gauges.

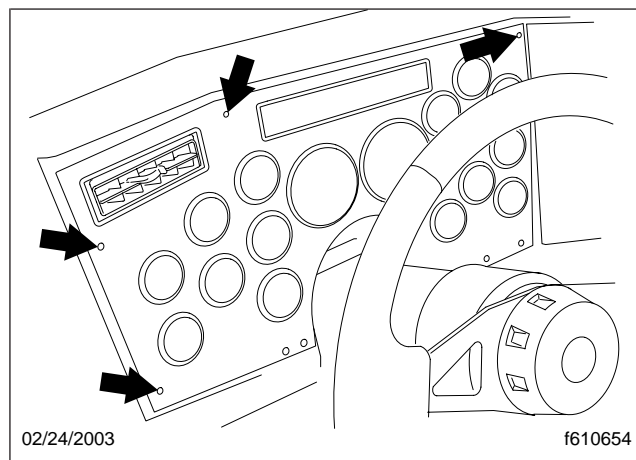

Fig. 1, Main Instrument Dash Panel Fasteners

3. Unplug the connector from the back of the gauge.

NOTE: If the removal tool is not available, use a pair of channel locks.

4. Place the appropriate gauge removal tool (p/n 87340-4404) over the retaining ring.
5. Insert the end of a hand ratchet into the end of the removal tool and unscrew the retaining ring.
6. Remove the gauge from the dash panel.
7. Install the new gauge. Refer to [Table 1](#) for the correct gauge.
8. Insert the gauge into the dash panel and align the index tab with the slot in the panel.
9. Slide the retaining ring onto the back of the gauge and tighten it finger-tight.
10. Place the gauge removal tool over the retaining ring, and using a small torque wrench inserted into the end of the removal tool, tighten the ring to 35 lbf-in (40 N-cm). If the removal tool is not available, tighten carefully using a pair of channel locks.

NOTICE

Over-tightening of the gauge retaining ring will cause the retaining ring to weld to the gauge, making it impossible to remove the gauge without damaging it.

11. Plug the connector into the back of the gauge.
12. Close the instrument panel and secure with the four fasteners.

Warranty

This procedure is warrantable only if the described condition exists and the repair is performed within the applicable base or extended coverage warranty period. If a failure is not found, this procedure is considered preventive and warranty does not apply.

Normal warranty applies. See [Table 2](#) for QuickClaim damage code and labor allowance information. Refer to this service bulletin by number at the beginning of the claim comments. See [Table 3](#) for OWL VMRS codes and labor allowance information. Enter this service bulletin number in the *Service Bulletin #:* field.

QuickClaim Damage Code and Labor Allowance			
Damage Code	SRT Code	Description	Time: Hours
844-001910600	844-5015A	Gauge, Fuel Level, R/R	0.2

Table 2, QuickClaim Damage Code and Labor Allowance

OWL VMRS Codes and Labor Allowance				
Component Code	Cause Code	SRT Code	Description	Time: Hours
003-001-020	33	844-5015A	Gauge, Fuel Level, R/R	0.2

Table 3, OWL VMRS Codes and Labor Allowance