

FLA COE
 FLB COE
 > FLD Conventional
 Business Class

FLC 112 Conventional
 > Century Class Conventional
 Argosy COE
 Cargo

> Columbia
 > Coronado
 > Business Class M2
 > Cascadia

Description of Revisions: This bulletin replaces the version dated March 2010. A new figure is added to clarify the components of the slip clamp assembly.

General Information

Early style bellows used on the CGI of EPA07 Caterpillar engines are prone to fatigue, which can lead to bellows failure and possible engine damage when not properly maintained. A new more robust bellows has been designed and is now available through the PDCs. See **Table 1** for associated part numbers.

The bellows should be inspected regularly, and replaced before they fail. Inspection procedures and replacement requirements are being added to the vehicles' maintenance manuals. See **Table 2** for CGI bellows inspection and replacement schedule.

EPA07 CGI Exhaust Bellows Replacement Parts		
Description	Original Part Number	Replacement Part Number
CGI Bellows	04-24080-000 or 04-26501-000	04-29368-000
Clamp Assembly (2 each) See Fig. 1 .	TCPA25SD	TCX AMS030AM

Table 1, EPA07 CGI Exhaust Bellows Replacement Parts

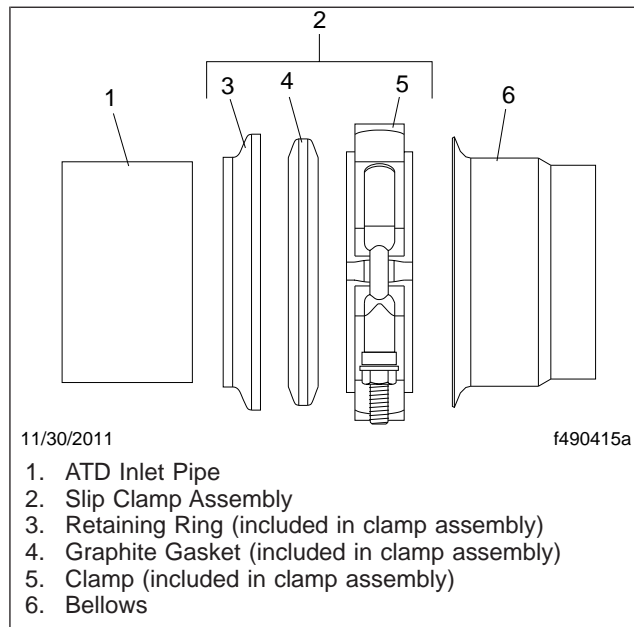

Fig. 1, Slip Clamp Assembly

CGI Bellows Inspection and Replacement Schedule		
Vehicle	Inspect	Replace
FLD Conventional	M1	M4
Century Class Trucks	M1	M3
Business Class M2	M1	M5
Cascadia	M1	M3

Freightliner Service Bulletin

FLA COE
FLB COE
> FLD Conventional
Business Class

FLC 112 Conventional
> Century Class Conventional
Argosy COE
Cargo

> Columbia
> Coronado
> Business Class M2
> Cascadia

CGI Bellows Inspection and Replacement Schedule		
Vehicle	Inspect	Replace
Columbia	M1	M3

Table 2, CGI Bellows Inspection and Replacement Schedule

Replacement

Refer to [Fig. 2](#) for this procedure.

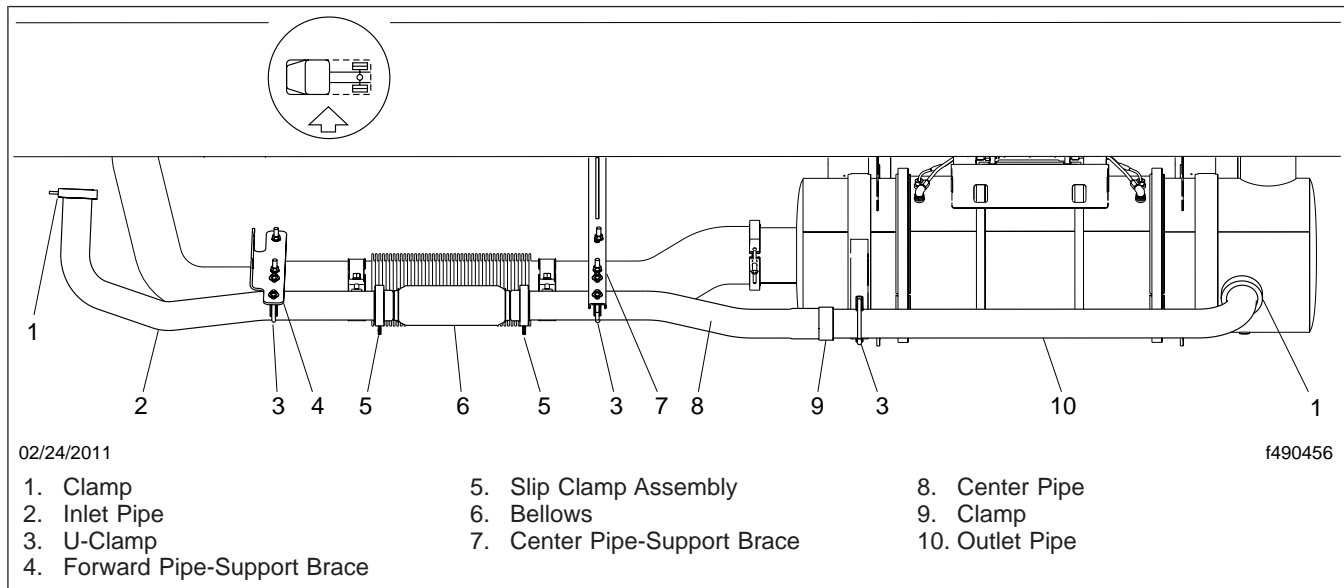

Fig. 2, CAT EPA07 Exhaust Installation with CGI Bellows

1. Park the vehicle, set the parking brake, chock the wheels.
2. Open the hood.
3. Remove the right side inner fender/splash shield as needed.
4. Remove the CGI piping between the engine and aftertreatment device (ATD).
5. On the workbench, remove the CGI bellows from the exhaust piping. Do not damage the piping.

NOTE: The following step, and its substeps, is to be done without the bellows installed. This will align the pipes so that the bellows can be installed correctly.

6. Install the CGI piping (without CGI bellows) and align piping.
 - 6.1 Attach the aft CGI pipe to the ATD.
 - 6.2 Attach the forward CGI pipe to the engine.

NOTICE

When the CGI pipes and bellows are installed, there should be approximately 3/4 inch (19 mm) clearance from the main bellows. Contact between the bellows could result in an exhaust leak, which in this case may allow ingestion of contaminants into the engine causing engine damage.

FLA COE
FLB COE
> FLD Conventional
Business Class

FLC 112 Conventional
> Century Class Conventional
Argosy COE
Cargo

> Columbia
> Coronado
> Business Class M2
> Cascadia

Freightliner
Service Bulletin

- 6.3 Use a straightedge to align the pipes so that the pipe ends that attach to the bellows are parallel and concentric.

NOTICE

When shortening the CGI pipe(s), it is critical to leave a minimum of 1 inch (25.4 mm) of straight pipe on the end of each CGI pipe to allow for pipe insertion and clamp clearance. Failure to do this could result in an exhaust leak, which in this case may allow ingestion of contaminants into the engine causing engine damage.

7. Once the pipes are aligned, measure the pipe gap between the CGI pipes and record the distance. See [Fig. 3](#), Ref. A.

The existing pipe gap is designed at 10 inches (254 mm). A 10.75 inches (273 mm) pipe gap is required for the replacement CGI bellows and clamps. This requires one or both of the CGI pipes to be shortened.

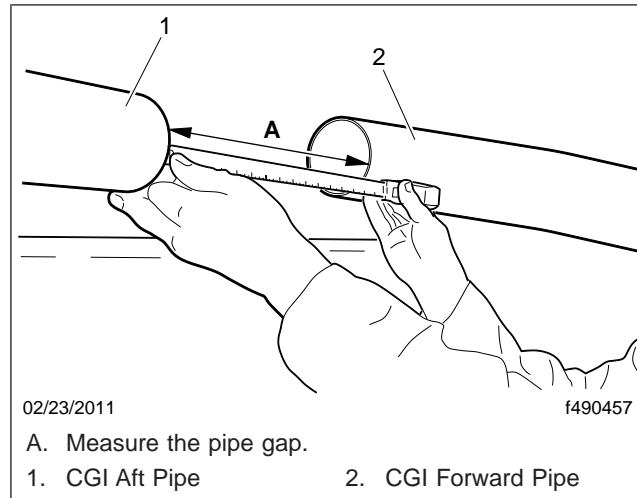

Fig. 3, Measuring the Pipe Gap (typical)

8. Using a yellow paint pen, mark the pipes 1.5 inches (38 mm) in from the end of each pipe. These two marks will be used to center the bellows between the two pipes.
9. Once the pipes are correctly aligned and separated at the correct distance, secure the aft CGI pipe to the ATD and to any CGI pipe support brackets.
10. Remove the forward CGI pipe from the truck.
11. Slide the slip clamp assembly, with the retaining ring and graphite gasket ring, on the aft CGI pipe. See [Fig. 4](#) for proper installation.
12. Slide the new bellows onto the aft CGI pipe as far as it will go. See [Fig. 5](#), Ref. A. Measurement A should be at least 7/16 inch (10 mm) past the face of the flange.
13. Install the slip clamp assembly with the retaining ring and graphite gasket ring, onto the forward CGI pipe. See [Fig. 6](#) for proper installation.
14. Slide the end of the forward CGI pipe into the bellows, and properly align the pipe.
15. Secure the forward CGI pipe to the engine and any CGI pipe support brackets.

Freightliner Service Bulletin

FLA COE
FLB COE
> FLD Conventional
Business Class

FLC 112 Conventional
> Century Class Conventional
Argosy COE
Cargo

> Columbia
> Coronado
> Business Class M2
> Cascadia

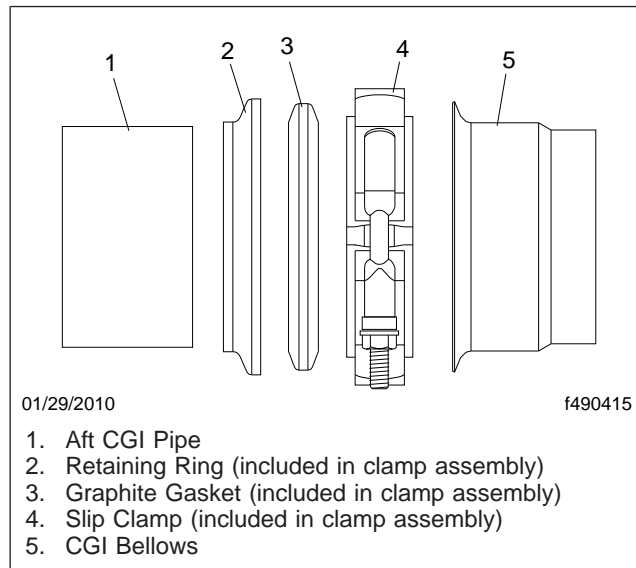

Fig. 4, Aft Facing Slip Clamp Installation

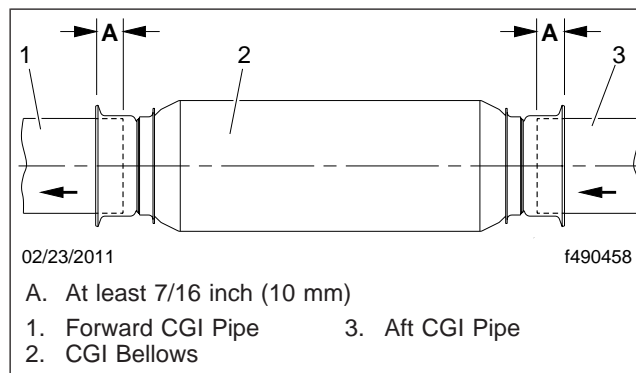

Fig. 5, CGI Bellows Installation

16. Using the yellow marks, center the bellows between the exhaust pipes. Verify that the pipe is inserted at least 7/16 inch (10 mm) past the face of the flange. See **Fig. 5**, Ref. A.
17. Install the slip clamp assemblies on the bellows. Tighten the slip clamps 11 lbf-ft (15 N-m).
18. Start the engine and check for exhaust leaks. Tighten any clamps as needed.

Parts

Parts are available through the PDC.

Warranty

This bulletin is informational only. Warranty does not apply.

FLA COE
FLB COE
> FLD Conventional
Business Class

FLC 112 Conventional
> Century Class Conventional
Argosy COE
Cargo

> Columbia
> Coronado
> Business Class M2
> Cascadia

**Freightliner
Service Bulletin**

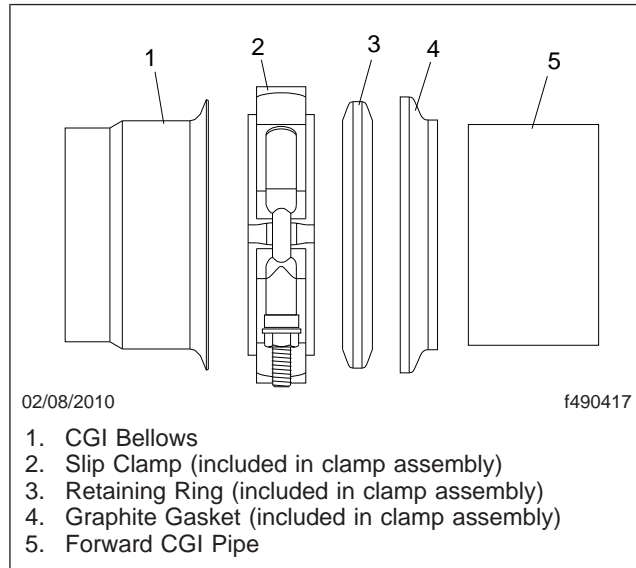

Fig. 6, Forward Facing Slip Clamp Installation