



Applies To: **2009 TSX L4 – ALL**
2010 TSX L4 – From VIN JH4CU2...AC000001 thru JH4CU2...AC027068

October 6, 2012

Engine Rattles at Cold Start-Up

(Supersedes 10-024, dated November 17, 2010; see REVISION SUMMARY)

REVISION SUMMARY

This service bulletin has been revised extensively. American Honda recommends that you review the entire bulletin.

SYMPTOM

At cold start-up, the engine rattles loudly for about 2 seconds.

PROBABLE CAUSE

The variable valve timing control (VTC) actuator is defective.

CORRECTIVE ACTION

Replace the VTC actuator. This procedure does not require the complete removal of the cam chain and associated parts, so repair time is much shorter.

PARTS INFORMATION

VTC Actuator: P/N 14310-R40-A01

REQUIRED MATERIALS

Hondabond HT Liquid Silicone Gasket:
 P/N 08718-0004
 (One tube repairs about two vehicles.)

TOOL INFORMATION

Stopper (lock pin): P/N 14511-PNA-003
 Tappet Adjuster: P/N 07MAA-PR70110
 Tappet Locknut Wrench: P/N 07MAA-PR70120

WARRANTY CLAIM INFORMATION

The normal warranty applies.

Operation Number: 1101Z9
 Flat Rate Time: 2.0 hours
 Failed Part: P/N 14310-R40-A01
 Defect Code: 03214
 Symptom Code: 04201
 Template ID: 10-024B

DIAGNOSIS

NOTE: If viewing this service bulletin on ISIS and your computer has sound, [click](#) on the picture below to hear a sample of the engine's rattle.



1. Allow the engine oil to drain from the VTC system by not starting the engine **for at least 6 hours**.
2. Start the engine, and immediately listen for a loud rattle.

On start-up, do you hear a loud engine rattle that lasts about 2 seconds?

Yes – Go to REPAIR PROCEDURE.

No –

- If you hear a different noise, continue with normal troubleshooting.
- If you don't hear an abnormal noise, get more information from the client and, if needed, continue with normal troubleshooting.

REPAIR PROCEDURE

NOTE: This procedure is in an outline form that you can also use as a checklist for the repair. If you need more details, bookmark the following procedures in the *2009–2010 TSX Service Manual*, or view them online:

- Cylinder Head Cover Removal
 - Cylinder Head Cover Installation
 - Valve Clearance Adjustment
1. Remove the frame (strut) brace (if equipped).
 2. Remove the engine cover.



CLIENT INFORMATION: The information in this bulletin is intended for use only by skilled technicians who have the proper tools, equipment, and training to correctly and safely maintain your vehicle. These procedures should not be attempted by “do-it-yourselfers,” and you should not assume this bulletin applies to your vehicle, or that your vehicle has the condition described. To determine whether this information applies, contact an authorized Acura automobile dealer.

- Remove the ignition coil cover and the ignition coils.

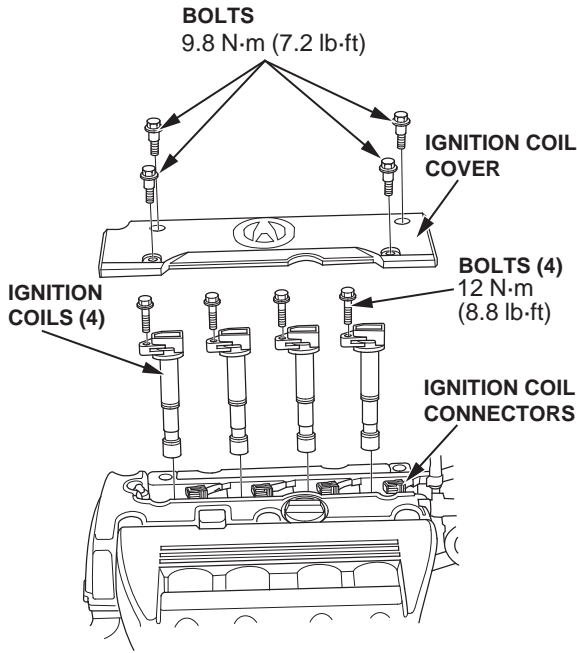

- Remove the engine oil dipstick, then disconnect the breather hose and the brake booster vacuum hose from the cylinder head cover.

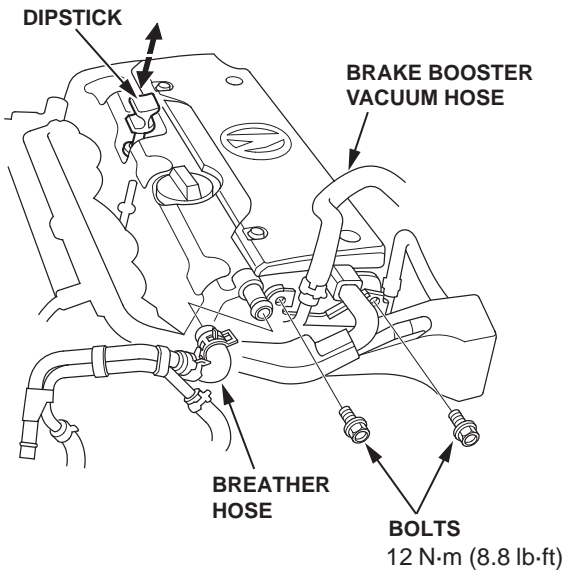

- Remove the two bolts holding the EVAP canister purge valve bracket to the cylinder head.
- Remove the cylinder head cover.
- Raise the vehicle on a lift.
- Turn the front wheels or remove the right front wheel.
- Remove the splash shield to provide access to the crankshaft pulley.

- Remove the camshaft auto-tensioner (chain case) cover.
- Rotate the crankshaft clockwise to top dead center (TDC) No. 1 cylinder.
- Rotate the crankshaft counterclockwise to compress the auto-tensioner. Align the hole in the lock and auto-tensioner, then insert a 1.2 mm (0.05 in) diameter stopper (lock pin).

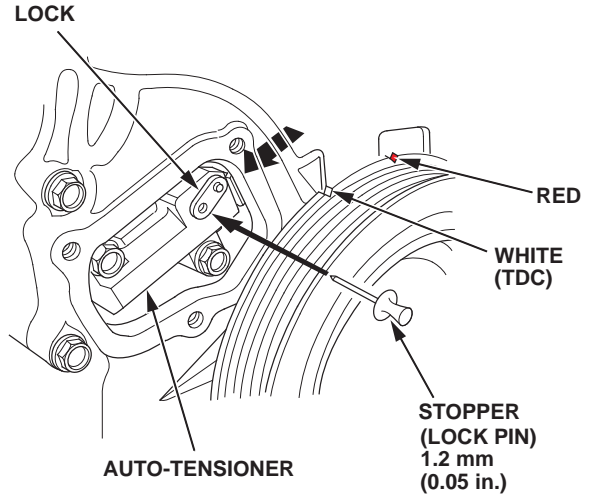

- Rotate the crankshaft clockwise to TDC No. 1 cylinder.
- Lower the vehicle.
- Mark the timing chain at the punch marks on the exhaust camshaft sprocket and VTC actuator. Secure the chain to the sprocket with a wire tie.

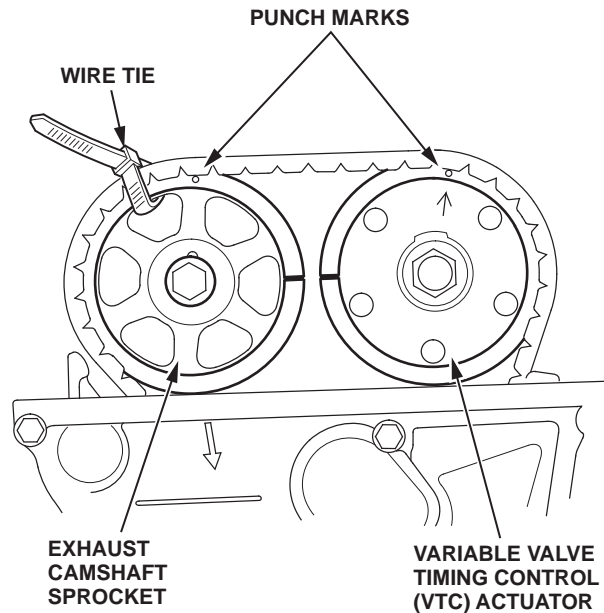

- Loosen the camshaft holder bolts, in sequence, two turns at a time.

17. Remove the five camshaft holders. Set them aside on a clean surface in the exact order and position that they were removed from the cylinder head.
18. Carefully tip up the end of the intake camshaft until there is enough slack for an assistant to lift the chain off the VTC actuator teeth.
19. Remove the intake camshaft/VTC actuator assembly while the assistant keeps light tension on the chain. Place the camshaft/VTC actuator assembly on a clean, padded workbench.
20. Secure the timing chain to the A/C compressor hose using a wire or zip tie to keep it from falling into the front cover.
21. On the workbench, as an assistant holds the camshaft steady with an open-end wrench, remove the actuator mounting bolt, then separate the VTC actuator from the camshaft. Discard the faulty actuator.



22. Before installing the new VTC actuator, make sure it is in the unlocked position.

VTC ACTUATOR

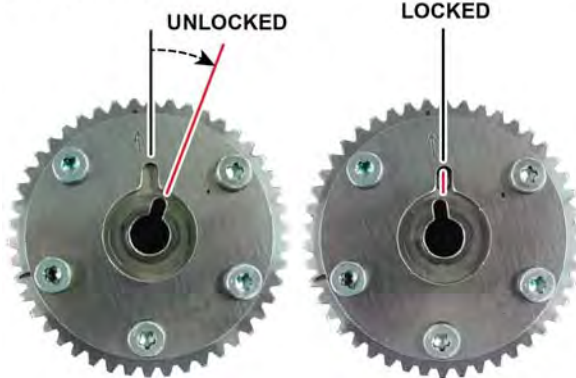

23. Install the new, unlocked VTC actuator onto the camshaft; do not force it on.

24. Once fitted, with the VTC actuator facing you, carefully rotate it **counterclockwise** until it engages the camshaft's locator pin. When installed and rotated this way, the VTC actuator will not lock. Apply clean engine oil to the mounting bolt threads, then install the mounting bolt finger tight.

NOTE: If the new VTC actuator is unlocked after installation on the camshaft, proceed to step 28. If the actuator is locked following installation on the camshaft, go to step 25..

25. To **unlock** a locked VTC actuator, apply clean engine oil to the mounting bolt threads, then install the mounting bolt on the actuator finger tight.
26. Seal pressure port #1 on the camshaft with several wraps of electrical tape. Secure the tape with a zip tie, as shown.

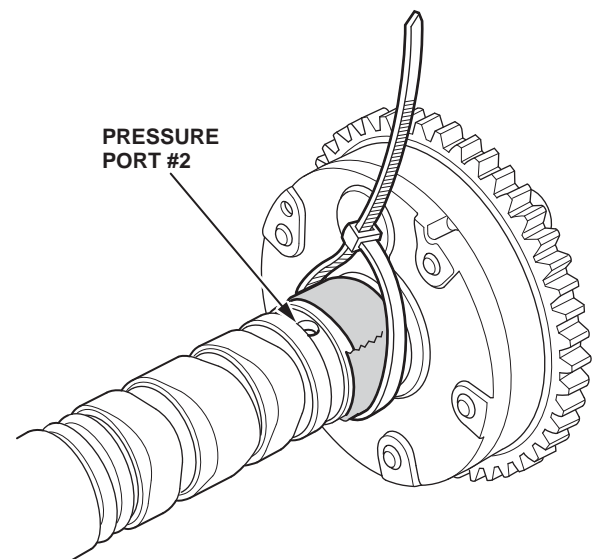
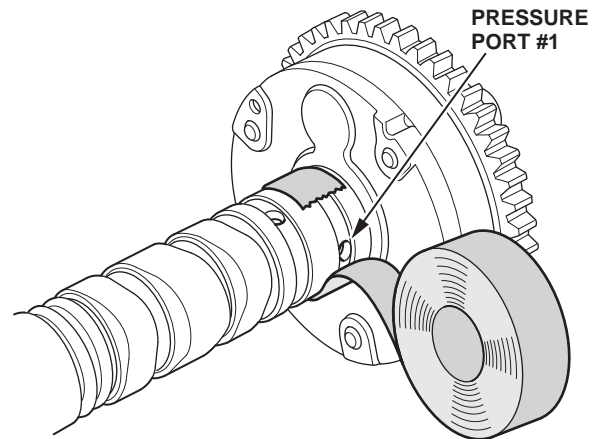

27. Apply compressed air to pressure port #2. While air pressure is applied to pressure port #2, rotate the VTC Actuator by hand in the direction shown (as needed) to unlock the VTC Actuator.

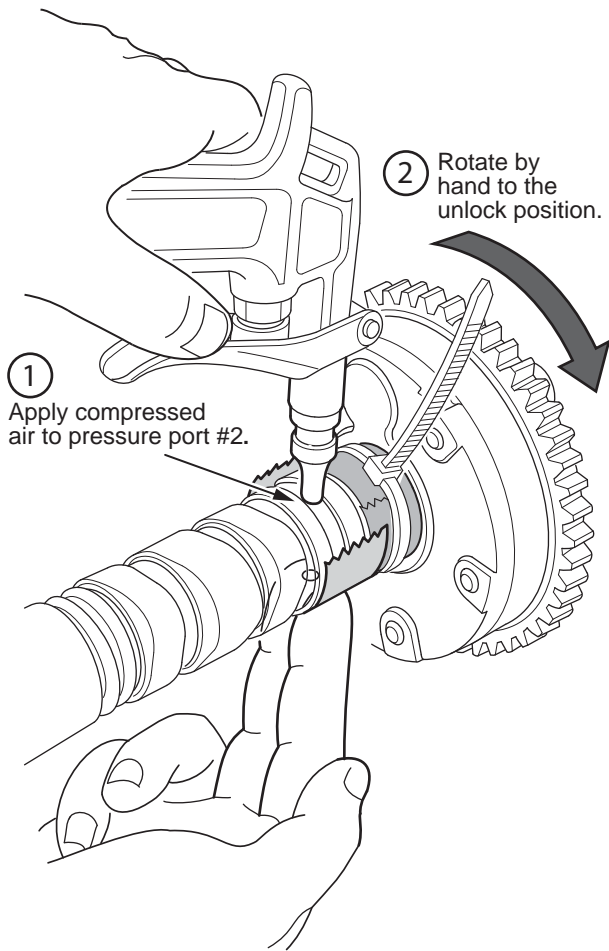

Verify the actuator has moved to the unlock position.

VTC ACTUATOR

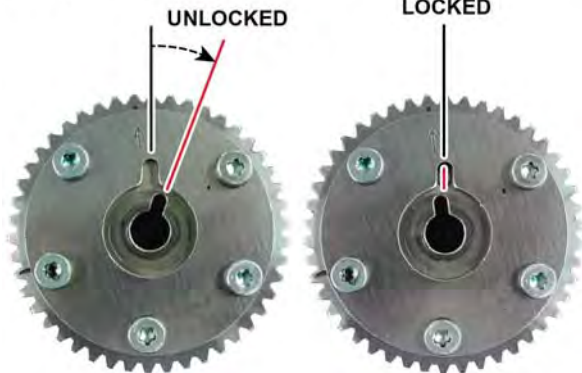

Afterward, make sure to remove all electrical tape and adhesive residue.

28. Have an assistant hold the camshaft/VTC actuator assembly steady on the padded workbench with an open-end wrench, use a torque wrench to torque the mounting bolt to **113 N·m (83 lb-ft)**.

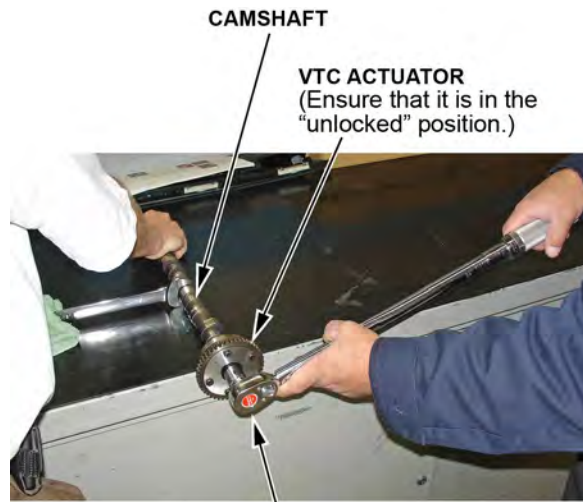

Torque to 113 N·m (83 lb-ft).

NOTE: Be careful to not scratch or damage the camshaft. Also, **do not** use an impact wrench to tighten the mounting bolt; it will cause internal damage to the VTC actuator housing, vanes, or lockpin.

29. After the mounting bolt is torqued, rotate the VTC actuator to the locked position.
30. Remove the wire tie holding the chain to the AC compressor as an assistant keeps light tension on the chain.
31. Slide the camshaft/VTC actuator in at an angle so that the chain can slip over the actuator's teeth.

32. Line up the marks you made on the chain with the punch marks on the exhaust camshaft sprocket and VTC actuator.

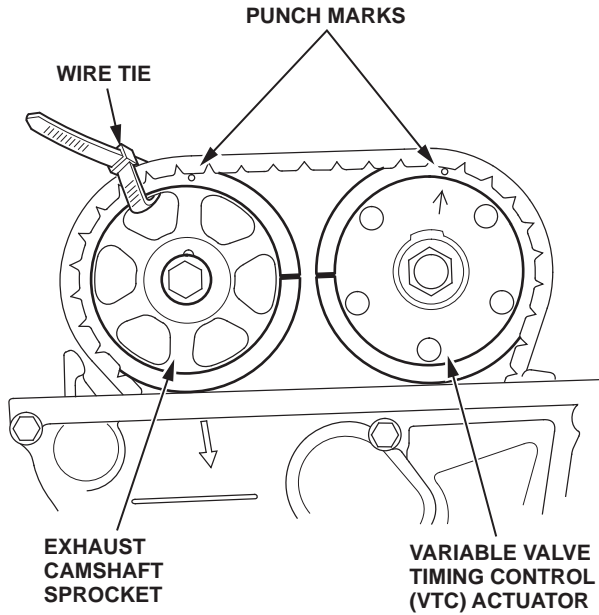

33. Apply engine oil to the journals and caps for both camshafts. Lower the camshaft/VTC actuator assembly onto its journals.
34. Install the camshaft holders. Tighten them down two turns at a time, starting in the middle and working your way outward, following the numbered sequence.

Torque
 8 x 1.25 mm
 22 N·m (16 lb·ft)
 6 x 1.0 mm
 12 N·m (8.7 lb·ft)
 6 x 1.0 mm Bolts: (21), (22), (23)

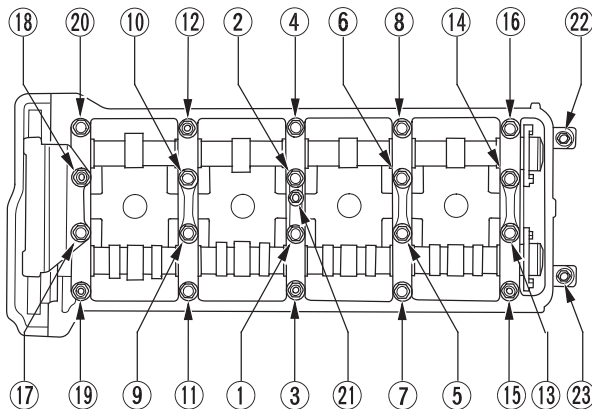

35. Remove the lock pin from the auto-tensioner, then remove the wire tie from the exhaust cam sprocket.

36. Rotate the crankshaft in the direction of engine rotation (clockwise) two full turns, then stop at the white TDC mark. Make sure both camshafts line up, as shown in step 15.

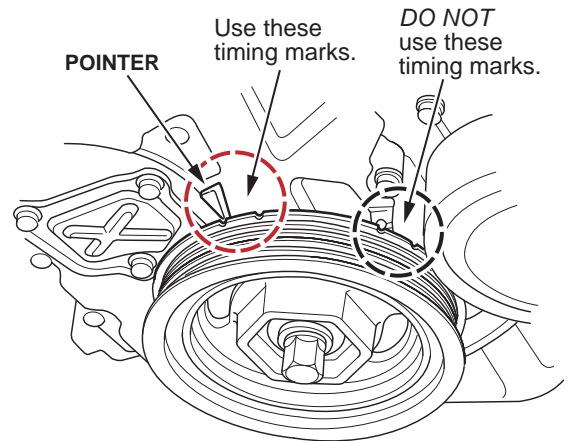

37. Inside the cylinder block, visually confirm that the timing chain is properly riding on its guide, and has not slipped behind the guide in the block. If so, realign the chain as needed.
38. Remove the old sealant, dry, reseal, then reinstall the auto-tensioner (chain case) cover.

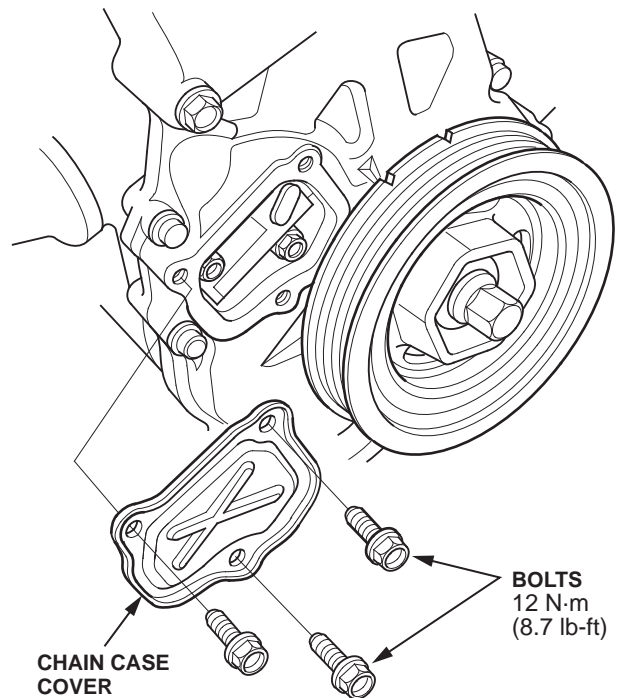

NOTE: Wait 30 minutes before adding oil, if needed, and wait 3 hours before starting the engine.

39. Check and, if needed, adjust the valve clearance using a tappet adjuster.

Intake: 0.21 - 0.25 mm (0.008 - 0.010 in)

Exhaust: 0.25 - 0.29 mm (0.010 - 0.011 in)

40. Following adjustment, use a tappet locknut wrench to torque the locknuts.

Intake and Exhaust: 14 N·m (10 lb-ft)

41. Raise the vehicle.

42. Reinstall the splash shield.

43. Straighten the wheels or reinstall the right front wheel (if removed).

44. Lower the vehicle.

45. Reinstall the cylinder head cover, tightening the bolts in three steps. In the final step, tighten all bolts, in sequence, to **12 N·m (8.7 lb-ft)**.

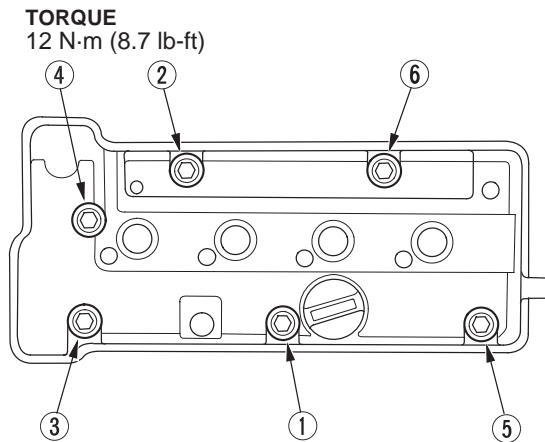

46. Reinstall the EVAP canister purge valve bracket.

47. Reinstall the engine oil dipstick, and reconnect the breather hose and the brake booster vacuum hose.

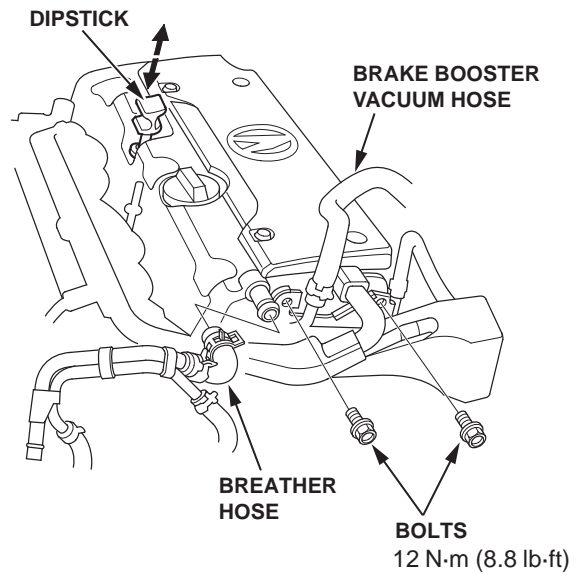

48. Reinstall the ignition coils and the ignition coil cover.

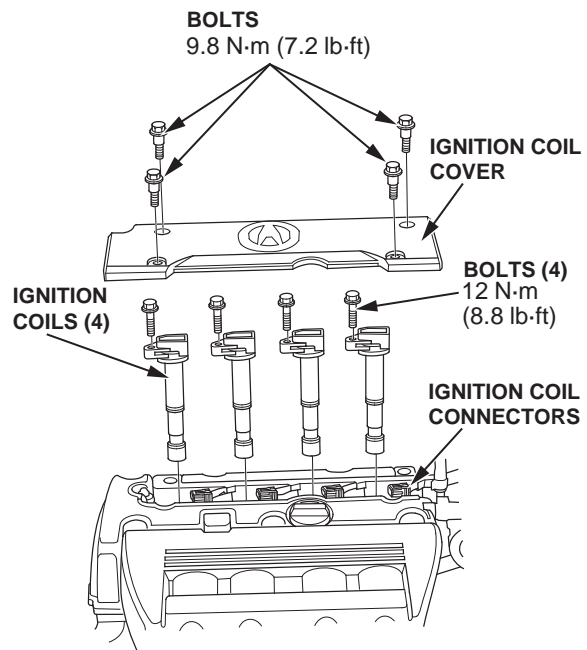

49. Reinstall the engine cover.

50. Reinstall the frame (strut) brace (if equipped). Torque the bolts to **22 N·m (16 lb-ft)**.