

SB-10037065-6239SI M11 02 07
EngineMay 2012
Technical Service

This Service Information bulletin supersedes SI M11 02 07 **dated April 2012.**

NEW designates changes to this revision

SUBJECT**Rattle Noise from Engine****MODEL**

R55 Cooper S with N14 engine

R56 Cooper S with N14 engine

From start of production up May 4, 2009

NEW SITUATION

The customer complains of a rattle noise from the engine.

- During cold start-up: most often at the 1,600-1,800 rpm range, or in some instances (elongated timing chain) from the idle speed up to 2,000 rpm.
- The rattle noise occurs more frequently when driving short distances.
- The noise is more prevalent when the outside temperature is approximately 15 Celsius (59 Fahrenheit) or below.

CAUSE

The complaint can be caused by one or both of the following reasons:

- Insufficient tension of the timing chain
- The chain tensioner has not been bled sufficiently.

PROCEDURE

Work through the following procedure in order to eliminate other possible causes:

1. If a fault is stored in the DME memory (e.g., misfiring, VANOS, etc.), then work through all relevant test plans first.

Note: When the ISTA system message displays :

Battery voltage only "XX.XX" V. Please connect charger.

Please note the displayed battery voltage reading in the repair order comments section.

2. A one-off short shrill will be heard within the first two seconds of engine operation. This is an

inherent noise caused by the first regulation cycle of the engine oil pump. This is normal operation and no parts should be replaced.

3. If the noise appears to be coming from the valve cover or the vacuum pump area, refer to [SIM11 02 08](#). To verify the source of the noise, disconnect the vacuum hose from the mechanical vacuum pump to eliminate the knocking noise. This is not a failure of the mechanical vacuum pump; do not replace any parts.
4. Ensure that the noise is not created or eliminated by depressing the clutch pedal, if equipped.
5. Disconnect the electrical connector from the tank ventilation valve. If the noise disappears when the connector is removed, reconnect to verify whether the noise returns. If the noise returns, replace the tank ventilation valve.

If all of the steps above are unsuccessful in eliminating the noise, please proceed to step 6.

6. Remove the right-hand wheel arch trim to access the crankshaft central bolt.
7. **NEW** Disconnect the battery and remove the ignition coils and the spark plugs. Turn the engine in the clockwise direction by hand to move the flywheel to approximately 90° before TDC. Rotating the engine counterclockwise may cause an incorrect measurement.

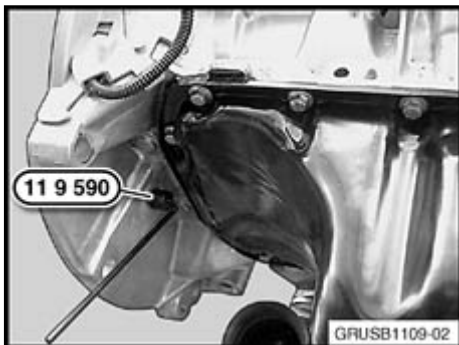

8. Install the locating pin (Special Tool 11 9 590) to lock the position of the engine.

NEW Note:

Do not remove the cylinder head cover! Do not install camshaft locking tool during this procedure. To achieve an accurate measurement, the camshafts need to rotate.

9. Remove the chain tensioner and collect the residual oil with a shop towel.

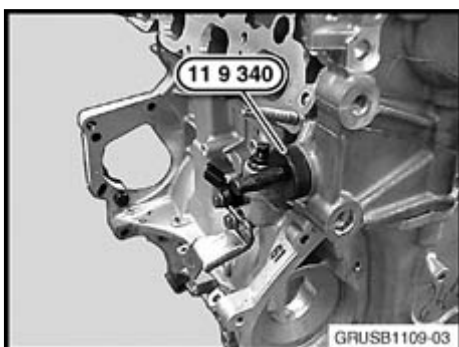

10. Fit the chain tensioner (Special Tool 11 9 340) without the seal ring and with the lock nut loose. Pretension the chain tensioner with Special Tool 00 9 250 to **0.6 Nm**. Finger-tighten the lock nut on Special Tool 11 9 340.

NEW Note:

Gently turn Special Tool 00 9 250 while applying the torque. Quickly rotating the tool will provide an inaccurate measurement result.

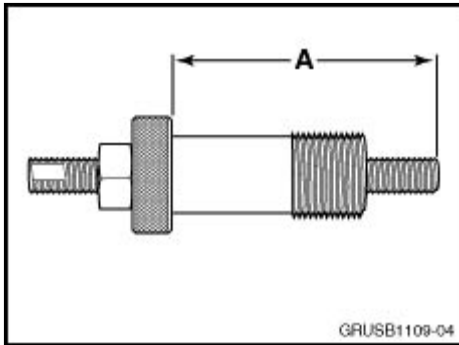

11. **NEW** Remove the chain tensioner Special Tool 11 9 340 from the engine, with the lock nut still tight. Measure the distance (A), as described in the illustration.

12. **NEW** If distance (A) is less than 68mm (and the noise can be reproduced only between 1,600-1,800 rpm), only replace the chain tensioner with P/N 11 31 7 607 551 and substitute the seal ring supplied with the new chain tensioner with improved seal ring P/N 11 31 7 631 972 (refer to parts list A).

Discard the seal ring that was originally supplied with the new timing chain tensioner. Refer to Repair Instruction REP 11 31 090 (Installing and removing/replacing chain tensioner piston N14).

13. **NEW** If distance (A) is 68mm or greater (and the noise is reproducible both at 1,600-1,800 rpm range as well as at idle speed when cold), replace the following components in the list below (refer to parts list B).
- Guide rail
 - Tensioner rail
 - Sliding rail
 - Sprocket on the crankshaft
 - Bearing bolts for the tensioner and guide rails

NEW If you are uncertain regarding repair attempts already made, each chain tensioner part number is stamped on the outer sleeve. It must be removed from the engine in order to read the part number.

Install timing chain tensioner P/N 11 31 7 597 895 and improved seal ring P/N 11 31 7 631 972 only! Discard the seal ring that was originally supplied with the new timing chain tensioner.

NEW Note: P/N 11 31 7 607 551, Timing chain tensioner should not be installed with a new timing chain.

Refer to Repair Instruction REP 11 31 051 (Replacing timing chain N14).

Refer to the EPC for additional parts required, i.e., gaskets, seals, etc.

The incorrect crankshaft central bolt tightening torque is stated in the current release of ISTA. Disregard the torque specified in the current Repair Instructions when performing repairs that include replacing the crankshaft central bolt, P/N 11 21 7 585 184. The correct torque specification is described below.

11 21 Crankshaft and Bearings

1 AZ	Type	Thread	Tightening	Measure
Torsion	N14	M14 x 1.5 x 74	specification	
Dampener (hub) to crankshaft (central bolt)			Replace screws Lightly oil screws and threads	
			Jointing torque	50 Nm
			Torque angle	180°

Do not replace the hydraulic valve lifters (HVA), intake camshaft VANOS adjustment unit, or the exhaust camshaft sprocket for this type of noise. It is NOT necessary to obtain a Part Replacement Authorization (TeileClearing) for this specific issue. Refer to the Warranty section of this bulletin for more details.

14. **NEW** After the repair is completed, reprogram the vehicle with the current version of ISTA/P. The new DME calibration software includes optimized injection timing strategy, as well as an increased operating pressure, improving the injector's operation.

Manual transmission vehicles: R056-09-12-520 or lower

or

F21 AISIN automatic transmission vehicles: R056-10-11-510 or lower

Note that ISTA/P will automatically reprogram and code all programmable control modules that do not have the latest software.

For information on programming and coding with ISTA/P, refer to Centernet / Aftersales Portal / Service / Workshop Technology / Vehicle Programming.

PARTS INFORMATION

Part Number	Description	Quantity
Parts List A		
11 31 7 607 551	Chain tensioner	1
11 31 7 631 972	Chain tensioner seal ring	1
Parts List B		
11 31 7 597 895	Chain tensioner	1
11 31 7 631 972	Chain tensioner seal ring	1

11 31 7 534 784	Timing chain	1
11 31 7 568 241	Guide rail	1
11 31 7 534 833	Tensioner rail	1
11 31 7 534 771	Bearing bolt	1
11 31 7 534 768	Bearing bolt	2
11 31 7 550 461	Bearing bolt gasket ring A14x21	1
11 31 7 546 697	Slide rail	1
11 21 7 534 654	Crankshaft sprocket	1
11 21 7 585 184	Bolt	1

Refer to the EPC for additional gaskets, seals and bolts, as described in Repair Instruction REP 11 31 051.

WARRANTY INFORMATION

Covered under the terms of the MINI New Passenger Car Limited Warranty or the MINI NEXT Certified Pre-Owned MINI Program, as applicable.

Defect Code	Refer to KSD2	See the note below
A. Repairs Performed Based on the Completion of Steps 1 through 5		
Labor Operation:	Labor Allowance:	Description:
00 00 006	Refer to KSD2	Performing vehicle test
and if necessary, also		
61 21 528	Refer to KSD2	Charging battery when the ISTA system message displays Battery voltage only "X.XX" V. Please connect charger.
11 99 000	4 FRU	Work time to perform repair procedure steps 2-5.

Note: Claims resulting from performing repair procedure steps 1 through 5 only, submit with the applicable defect codes and labor operations listed in KSD2 and the regular claim procedures that apply.

Labor operation code 00 00 006 is a main labor operation. If you are using a main labor code for another repair; use the plus code labor operation 00 00 556 instead.

Even though work time labor operation code 11 99 000 ends in "000"; it has a designated FRU allowance and as described above, it is not considered a main labor operation.

B. Repairs Performed Based on the Completion of Steps 1 through 12 or 13

Defect Code **11 31 04 39 00**

Labor Operation:	Labor Allowance:	Description:
00 00 006	Refer to KSD2	Performing vehicle test

and if necessary,
also

61 21 528	Refer to KSD2	Charging battery when the ISTA system message displays Battery voltage only "X.XX" V. Please connect charger.
-----------	---------------	---

11 99 000	10 FRU	Work time to perform repair procedure steps 2-11.
-----------	--------	---

Replace Piston for Timing Chain Tensioner (Parts List A)

11 31 590	Refer to KSD2	Replacing piston for timing chain tensioner (Parts list A)
-----------	---------------	--

or

Replace Timing Chain (Parts List B) and Programming/Encoding Control Units (as applicable)

11 31 555	Refer to KSD2	Replacing timing chain (Parts list B)
-----------	---------------	---------------------------------------

61 00 710	Refer to KSD2	Programming/encoding control unit(s), without CAS
-----------	---------------	---

or

61 00 720	Refer to KSD2	Programming/encoding control unit(s), with CAS
-----------	---------------	--

Refer to KSD2	Refer to KSD2	Concluding work (initializations) as described in the ISTA/P final report
---------------	---------------	---

Labor operation code 00 00 006 is a main labor operation. If you are using a main labor code for another repair; use the plus code labor operation 00 00 556 instead.

Even though work time labor operation code 11 99 000 ends in "000"; it has a designated FRU allowance and as described above, it is not considered a main labor operation.

If a control module fails to program correctly, or initialization is required, work through the Measures Plan and/or Final Report. Claim this additional work under the defect code listed in this bulletin, refer to the KSD2 for the labor operation codes and labor allowances.

Part replacement authorization is NOT required. Do NOT submit a TeileClearing PuMA case, FASTA data must be transmitted. When submitting a warranty claim, please include "replaced per SI M11 02 07" in the comments section.

Please refer to the Warranty Policy and Procedures Manual regarding add-ons, proper support,

documentation, claims submission and archiving requirements for claims, as applicable.

[MINI, a division of BMW of North America, LLC
Copyright © 2012 BMW of North America, LLC]