

Description of Revisions: *This bulletin replaces the version dated February 2011. A new figure is added to clarify the components of the slip clamp assembly.*

General Information

If you have a failed exhaust bellows on an EPA07 engine installation, replace it with a new style bellows, and two new matching clamps. Also, if vehicle currently has the early style turbo outlet pipe support bracket (p/n 04-24627-000) installed, replace it with a revised part (p/n 04-29024-000) that provides better support and reduces vibration. Refer to **Table 1** for the original and replacement part numbers. Refer to **Fig. 1** for the clamp assembly configuration.

NOTE: The two part numbers for each size clamp are only for packaging purposes. The clamps are the same for both part numbers, so clamps with either number can be used together.

Follow the procedure below, and refer to the *Western Star Workshop Manual* for vehicle specific information.

EPA07 Exhaust Bellows Replacement Parts			
Description	Original Part Number	Replacement Part Number	New Clamp Assembly Part Number
5-Inch Bellows	A04-25022-018	04-28522-000	TCX AMS015AM (2 ea) or TCX AMS015 (2 ea)
4-Inch Bellows	A04-25922-018	04-28578-000	TCX AMS014AM (2 ea) or TCX AMS014 (2 ea)
	A04-26193-018		
Turbo Outlet Pipe Support Bracket	04-24627-000	04-29024-000	—

Table 1, EPA07 Exhaust Bellows Replacement Parts

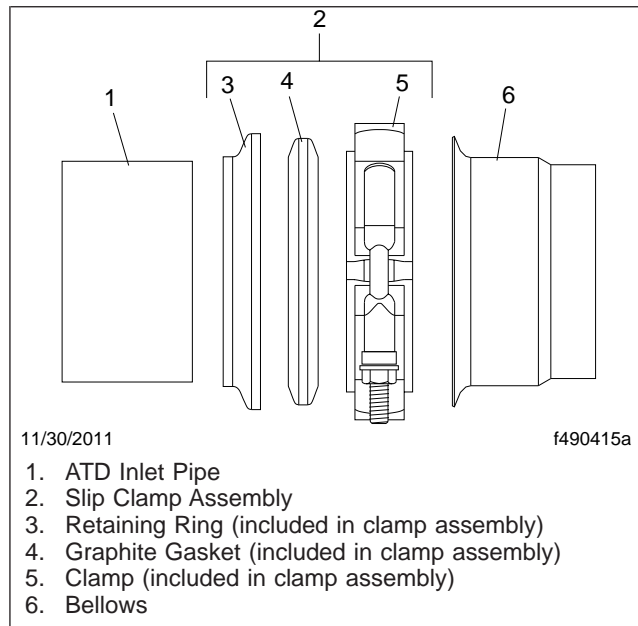

Fig. 1, Slip Clamp Assembly

Replacement

1. Remove the exhaust piping between the turbo and aftertreatment device (ATD).
2. On the workbench, remove the exhaust bellows from the exhaust piping. Do not damage the piping.

NOTE: The following step, and its substeps, is to be done without the bellows installed. This will align the pipes so that the bellows can be installed correctly.

3. Check and align the ATD inlet pipe with the turbo outlet pipe.
 - 3.1 Install the ATD inlet pipe on the ATD.
 - 3.2 Install the turbo outlet pipe on the turbo.
 - 3.3 Measure the vertical distance between the pipe ends and the frame rail. See [Fig. 2](#). This measurement must be the same for both pipe ends.
 - 3.4 Measure the horizontal distance between the pipe and the frame rail. See [Fig. 3](#). This measurement must be the same for both pipe ends.

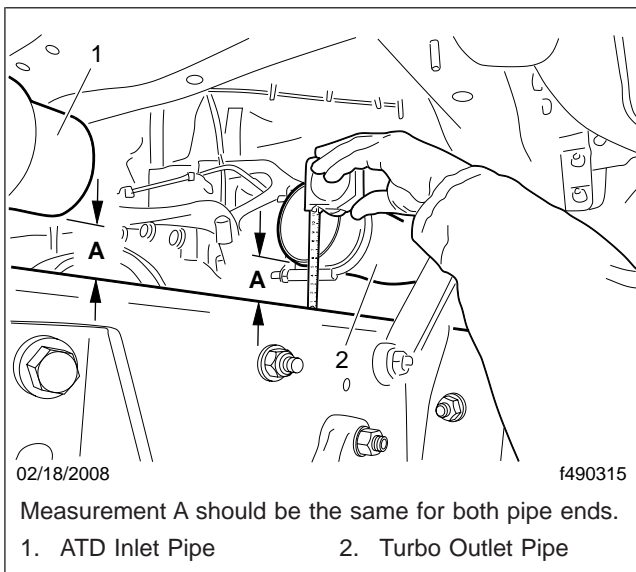

Fig. 2, Vertical Measurement

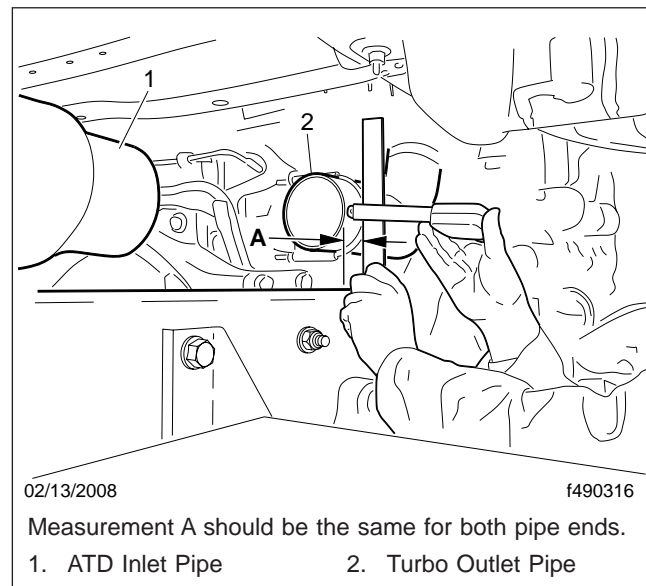

Fig. 3, Horizontal Measurement

4. Once the pipes are aligned and concentric, measure the distance between the ATD inlet pipe and turbo outlet pipe. See [Fig. 4](#).

The minimum distance should be 13-3/8 inches (340 mm), and the maximum should be 14-3/8 inches (365 mm). If they are too close together cut an equal amount off of each pipe to meet the minimum distance.

5. Using a yellow paint pen mark the pipes 1.5 inches (38 mm) in from the end of each pipe. These two marks will be used to center the bellows between the two pipes.
6. Once the pipes are correctly aligned and separated at the correct distance, secure the ATD inlet pipe.
7. Remove the turbo outlet pipe from the truck.
8. Slide the slip clamp assembly, with the retaining ring and graphite gasket ring, on the ATD inlet pipe. See [Fig. 5](#) for proper installation.

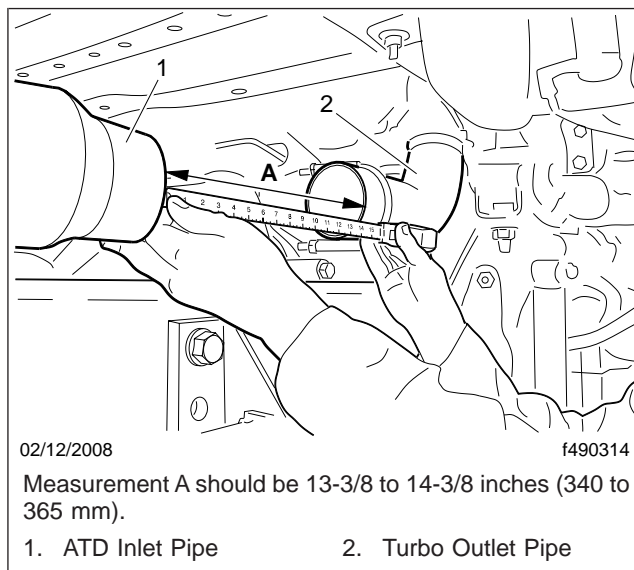

Fig. 4, Measuring Between the Pipes

9. Slide the new bellows onto the ATD inlet pipe as far as it will go. See [Fig. 6](#).

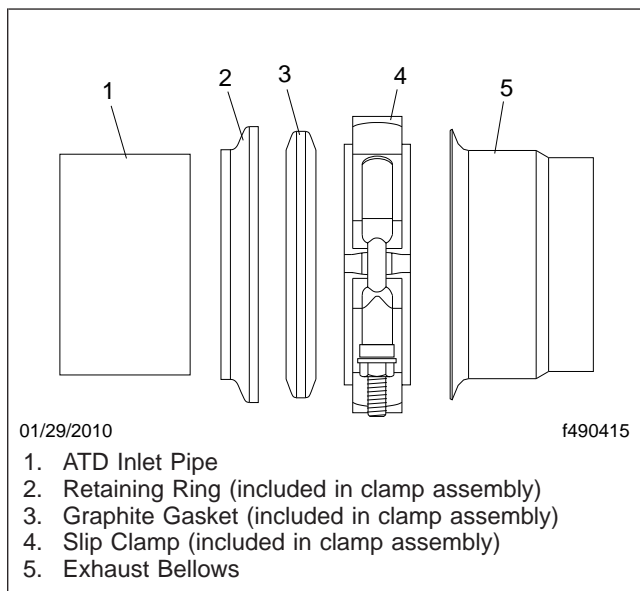

Fig. 5, Aft Facing Slip Clamp Installation

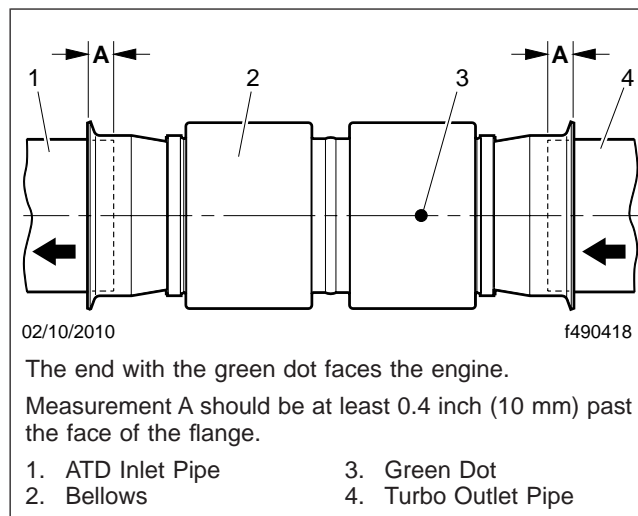

Fig. 6, EPA10 Exhaust Bellows

10. Install the slip clamp assembly, with the retaining ring and graphite gasket ring, onto the turbo outlet pipe. See [Fig. 7](#) for proper installation.
11. Slide the outlet end of the turbo outlet pipe into the bellows, and align the other end to the turbo.
12. If not already replaced, remove the old style turbo outlet pipe support bracket (04-24627-000) from the frame rail and discard it.

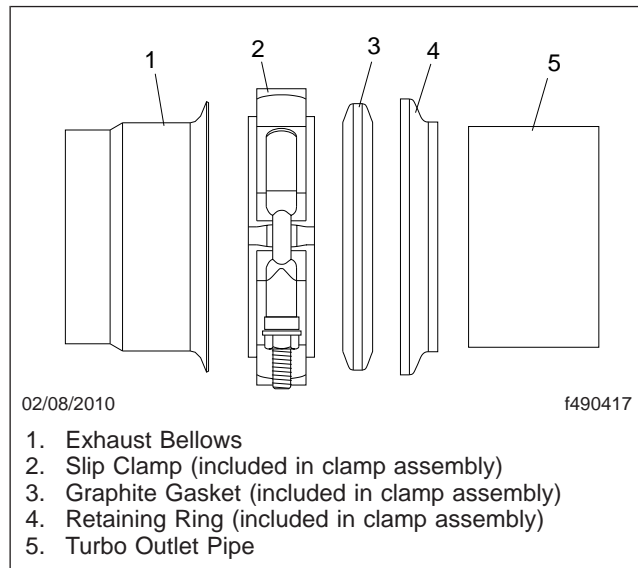

Fig. 7, Forward Facing Slip Clamp Installation

13. Install the new support bracket (04-29024-000). Tighten 103 lbf·ft (140 N·m).
14. Using the original clamp, secure the turbo outlet pipe to the turbo and pipe support bracket.
15. Using the yellow marks, center the bellows between the exhaust pipes. Verify that the pipe is inserted at least 7/16 inch (10 mm) past the face of the flange. See [Fig. 6](#).
16. Install the slip clamps on the bellows. Tighten the slip clamps 15 lbf·ft (20 N·m).
17. Start the engine and check for exhaust leaks. Tighten any clamps as needed.

Warranty

This bulletin is informational only. Warranty does not apply.