



# Service Bulletin

## PRELIMINARY INFORMATION

**Subject:** Accessory Soft Tonneau Cover Loose

**Models:** 2004-2012 Chevrolet Colorado  
2007-2013 Chevrolet Silverado  
2004-2012 GMC Canyon  
2007-2013 GMC Sierra

*This PI is being revised to add model years. Please discard PI0383A.*

The following diagnosis might be helpful if the vehicle exhibits the symptom(s) described in this PI.

### Condition/Concern

Some customers may comment that the accessory soft tonneau cover is loose.



A rivet (location shown circled in the graphic above) that retains the pivot blocks to the side rail assembly may have loosened or detached.

### Recommendation/Instructions

Do This	Don't Do This
Install new pivot block rivets to side rail assembly.	DO NOT replace the tonneau cover or side rails.

**Important:** When a pivot block rivet is found to be loose on either end of a tonneau side rail, always replace the rivets on BOTH of that rail's pivot blocks.

Verify the condition and install a new rivet to each pivot block on the affected side rail(s). Follow the steps below, starting with the front pivot block location.

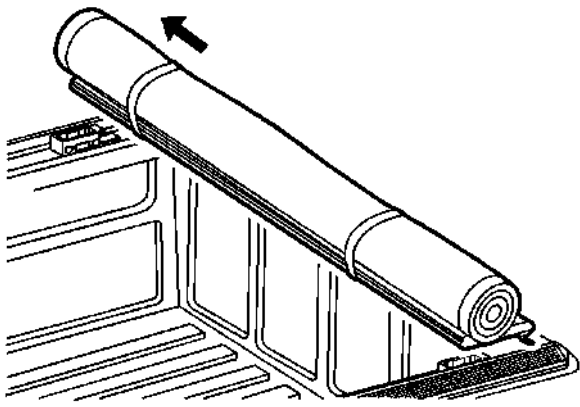

1. Remove the tonneau cover and the side rail(s) on the affected side. Refer to Soft Tonneau Cover Package Installation in SI.

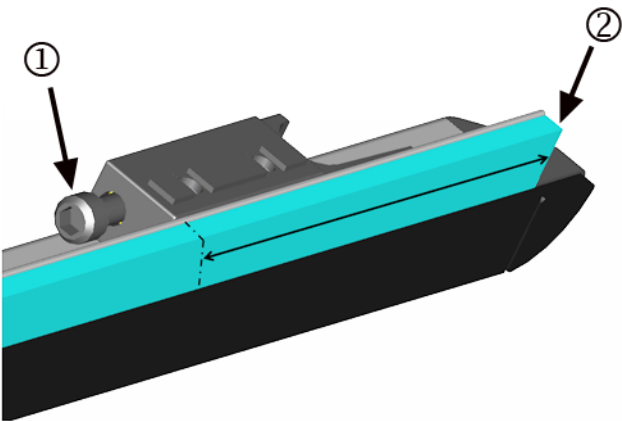

2. Remove the front tension adjustment screw (1).
3. In order to access the rivet on the pivot block, remove approximately 152 mm (6 in) from the end of the inboard foam tape (2) on the underside of the rail.

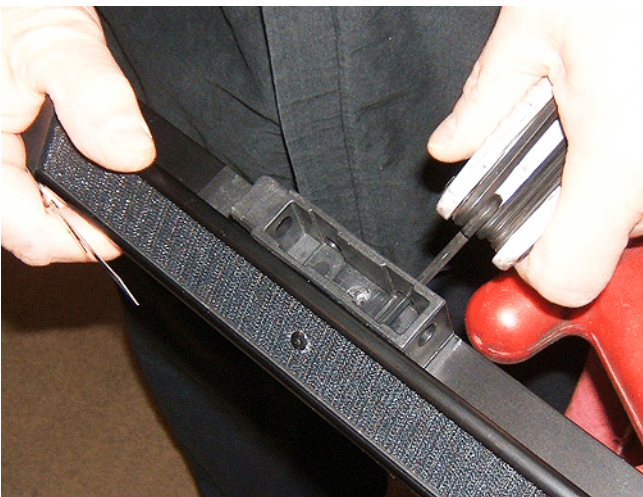

4. Loosen the two pivot block set screws securing the pivot block to the side channel of the rail assembly.

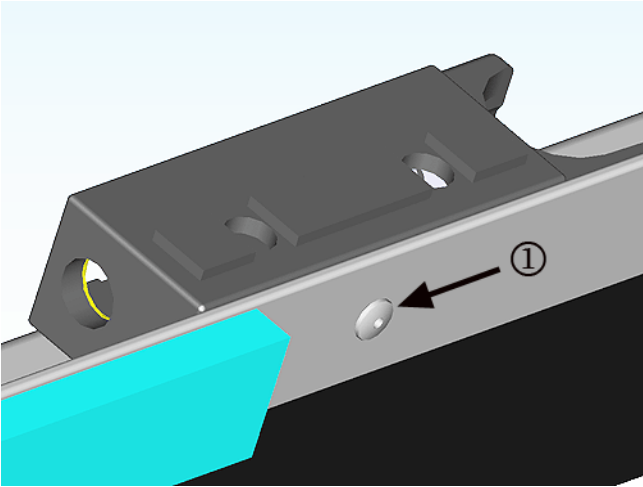

5. From the bottom side of the rail, use a 1/8 inch drill bit to drill out the old rivet (1).

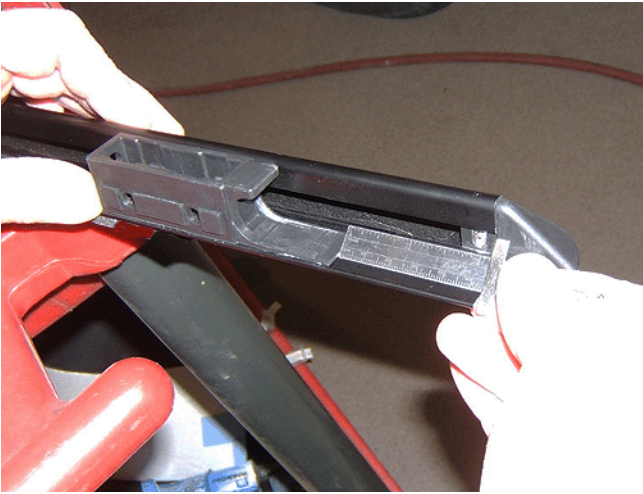

6. Reposition the pivot block 54.5 mm (2.15 in) from the end of the rail and re-secure the two set screws.

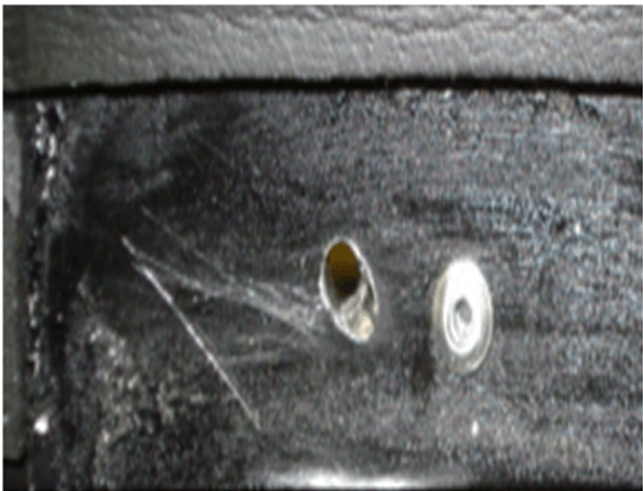

**Note:** A new hole is required for the rivet installation because the original hole may be distorted. For the front pivot block, drill the new hole forward of the original, and for the rear pivot block, drill the hole rearward of the original.

7. Layout the new hole position and drill an 1/8 inch hole through the side rail and the pivot block.
8. Remove any burrs and/or metal shavings from the underside of the rail and foam. Also clean any residue adhesive from the underside of the rail.

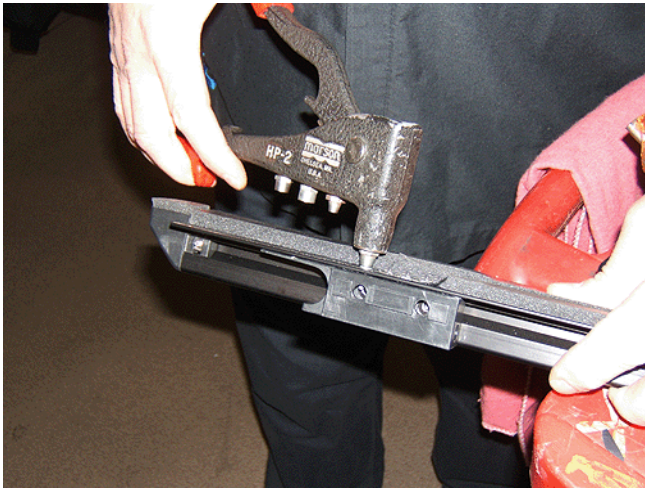

9. Install a new 1/8 x 1/4 inch long rivet (obtained locally) into the new hole and secure the rivet.
10. At the rail end where the original foam tape was removed, install a length of \*3M™ Scotchfoam™ Black Vinyl Foam Tape P/N 06370, or equivalent, to the underside of the rail.
11. Reinstall the tension adjustment screw to the pivot block. The tension adjustment should be performed during rail installation.
12. Repeat steps 3-10 to install a new rivet to the rear pivot block location.

**Note:** During reinstallation of the rail(s) and tonneau, pay particular attention to the positioning of the rails/clamps, along with the cover tensioning adjustment.

13. Reinstall the rail(s) and tonneau cover to the vehicle. Refer to Soft Tonneau Cover Package Installation in SI.

\* We believe this source and their products to be reliable. There may be additional manufacturers of such products/materials. General Motors does not endorse, indicate any preference for, or assume any responsibility for the products or material from this firm or for any such items that may be available from other sources.

## Parts Information

3M products may be purchased through your local distributor. Information about 3M product retailers in your area may be obtained by calling 1-866-364-3577 (U.S. and Canada).

Part Number	Description	Material Allowance
06370	3M™ Scotchfoam™ Black Vinyl Foam Tape (¼ in thick x ¾ in wide)	\$2.22

## Warranty Information

For vehicles repaired under warranty, use:

Labor Operation	Description	Labor Time
B9968*	Replace Pivot Block Rivets on Tonneau Side Rail	0.5 hr
Add	Repair Other Side Rail	0.3 hr

\*This is a unique labor operation for bulletin use only. It will not be published in the Labor Time Guide.

---

GM bulletins are intended for use by professional technicians, NOT a "do-it-yourselfer". They are written to inform these technicians of conditions that may occur on some vehicles, or to provide information that could assist in the proper service of a vehicle. Properly trained technicians have the equipment, tools, safety instructions, and know-how to do a job properly and safely. If a condition is described, DO NOT assume that the bulletin applies to your vehicle, or that your vehicle will have that condition. See your GM dealer for information on whether your vehicle may benefit from this information.



WE SUPPORT VOLUNTARY TECHNICIAN CERTIFICATION