



**Countries:** UNITED STATES **Document ID:** IK2200116  
**Availability:** ISIS **Revision:** 1  
**Major System:** BUS BODY **Created:** 4/30/2012  
**Current Language:** English **Last Modified:** 11/5/2012  
**Other Languages:** NONE **Author:** Charles Schroeder  
**Viewed:** 847

[Less Info](#)

Hide Details

Coding Information

Copy Link	Copy Relative Link	Bookmark	Add to Favorites	Print	Provide Feedback	Helpful	Not Helpful
		 <a href="#">View My Bookmarks</a>				 32	 10

**Title:** Bus Door Adjustment procedure for Electric and Air

**Applies To:** BE, CE, and RE Bus Models Built 9/15/11 or later

## DESCRIPTION

Adjustment procedure for:

Electric Operated Doors built 9/15/2011 and later  
 Air Operated Bus Doors built 9/15/2011 and later

## SYMPTOMS

- **Electric Door** - motor failures, water leaks, header box fit, bent adjustment rods, poor link arm clearance
- **Air Door** - doors blow open at highway speeds/high cross winds, poor closing force, water leaks, header box fit, poor link arm clearance, poor vandal lock operation, bent adjustment rods

## RESOLUTION

# Electric Door

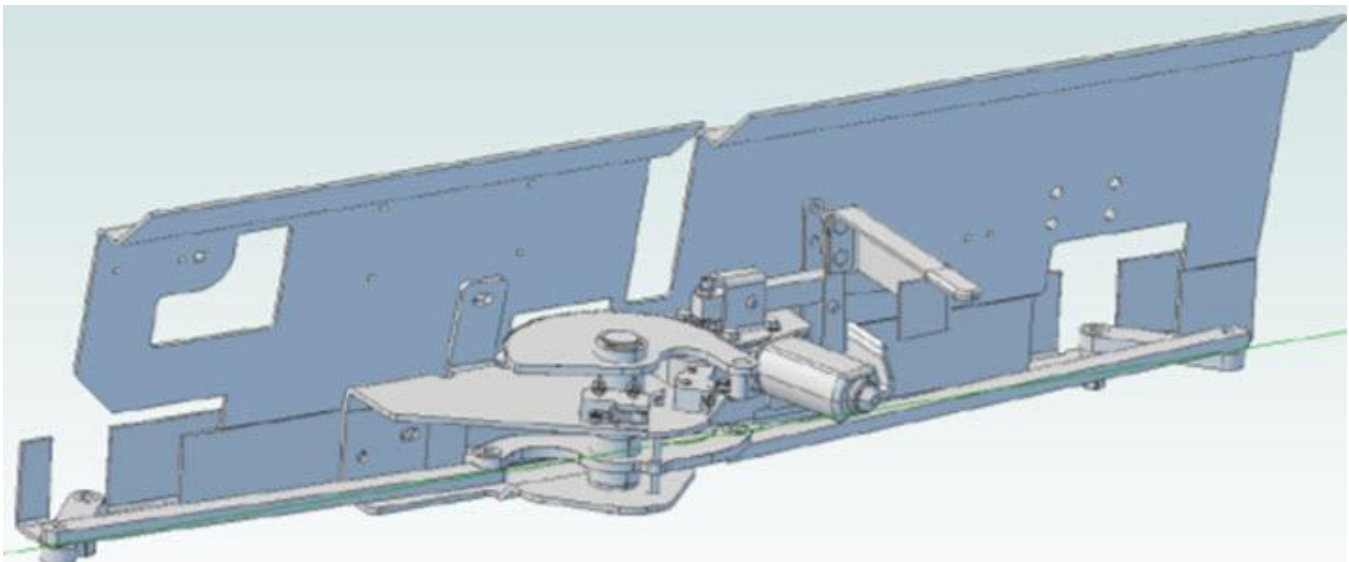

- **Power OFF**
- **Door Closed**

- Visually inspect actuator assembly.
- All fasteners should be properly tightened.
- Adjustable tie-bars should be straight.
- No interferences should be found in the moving components to the frame assembly.
- Gear plate to base assembly should be positioned near the mechanical stop.
- Base assembly closed alignment holes should be closely aligned allowing a 3/8" pin to be installed through the base assembly components.

**NOTE:**

Installation of the 3/8" pin is typically not required unless the door actuator assembly is being replaced requiring initial tie-bar adjustment. After final adjustment, the alignment holes will not be perfectly aligned.

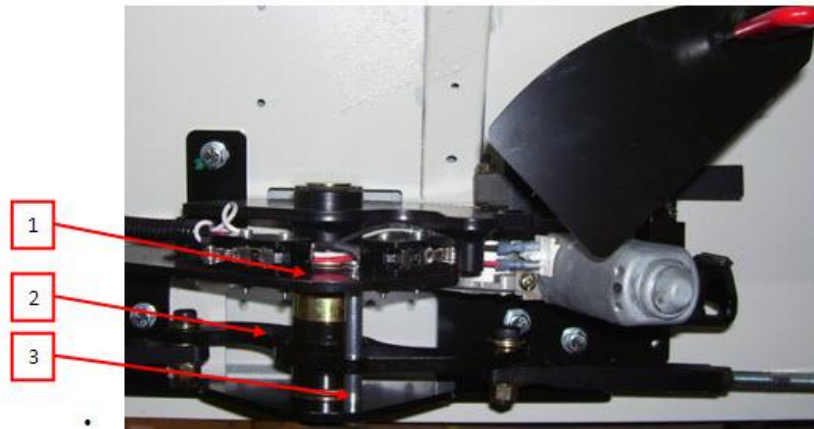

- 1) Base Assembly
- 2) "S" Cam
- 3) 3/8" pin

- Adjust closed micro switch outward to allow addition travel if required to gain travel toward the mechanical stop.



- 1) Open Micro Switch
- 2) Closed Mechanical Stop
- 3) Closed Micro Switch

- **Door Open**

- Visually inspect actuator assembly.
- No interferences should be found in the moving components to the frame assembly.
- Gear plate to base assembly should be positioned near the mechanical stop (Located on the underside of the gear plate).
- Adjust open micro switch outward to allow addition travel if required to gain travel toward the mechanical stop.

**NOTE:**

If the open or closed position referenced above is not achieved, loosening of the tie-bars or adjustment of the cylinder may be required.

- **Power ON**

- **Door Closed**

- Adjust aft door tie-bar to position aft door parallel to the upper door casing. Upper door casing seal should be compressed evenly across the aft door surface.
- Adjust forward door tie-bar to position forward door parallel to the upper casing. Upper door casing seal should be compressed evenly across the forward door surface.



1) Tie-Bar Assembly (Forward Shown)



Upper Door Casing Seal Evenly Compressed

- Adjust closed micro switch. Micro switch position should disengage power to the motor as the door achieves the full closed position.

- **Door Open**

- Adjust open micro switch. Micro switch position should disengage power to the motor as the door achieves the full open position.
- Verify door achieves 85 to 90 degree opening.
- Cycle door to confirm open and closed position is repeated and that no air gaps are seen.
- Install a test light on the motor or use a digital multi meter to confirm the open and close micro switch is disengaging power to the motor in the open and closed position. Test light should only be ON as the door is in transition.

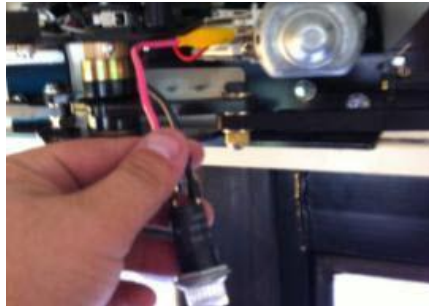

---

## Air Door

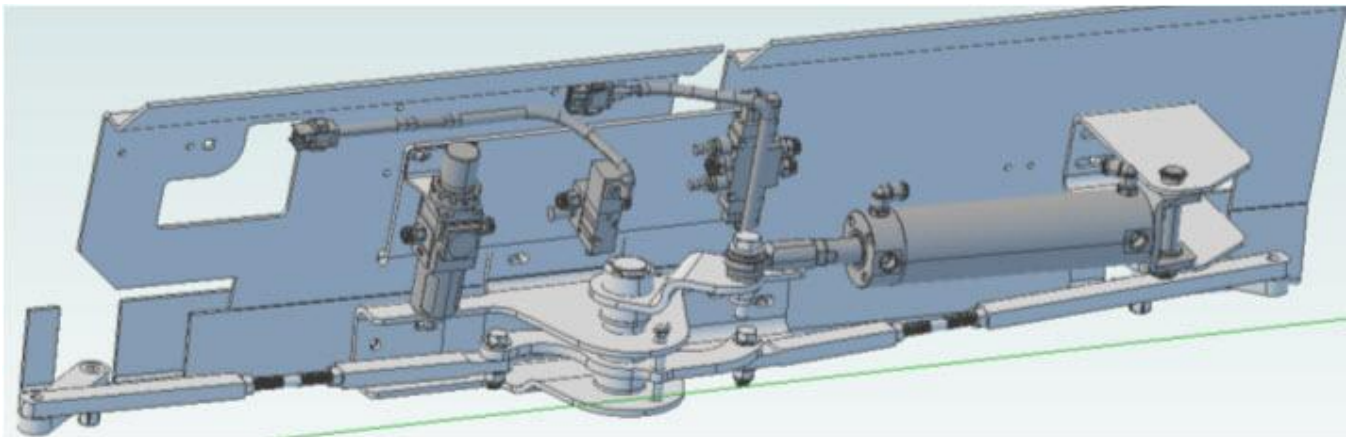

- **Power OFF**
- **Door Closed**
  - Visually inspect actuator assembly.
    - All fasteners should be properly tightened.
    - Adjustable tie-bars should be straight.
    - Air lines should not be kinked.
    - No interferences should be found in the moving components to the frame assembly.
- **Door Open**
  - Visually inspect actuator assembly.
    - No interferences should be found in the moving components to the frame assembly.

- **Power ON**
- **Door Closed**

- Base assembly closed alignment holes should be closely aligned allowing a 3/8" pin to be installed through the base assembly components.
- No interferences should be found in the moving components to the frame assembly.

**NOTE:**

Installation of the 3/8" pin is typically not required unless the door actuator assembly is being replaced requiring initial tie-bar adjustment. After final adjustment, the alignment holes will not be perfectly aligned.

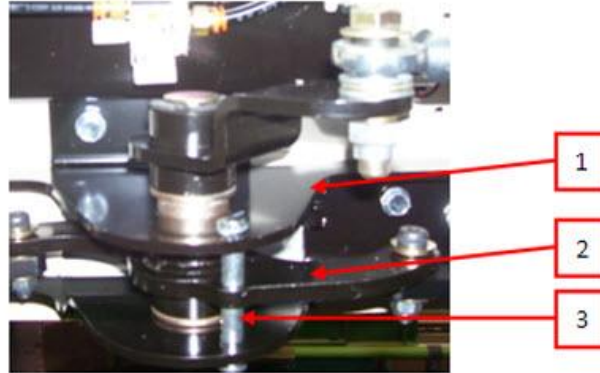

- 1) Base Assembly
- 2) "S" Cam
- 3) 3/8" pin

- **Door Open**

- No interferences should be found in the moving components or the frame assembly.
- "S" cam should be positioned near the base assembly mechanical stop.

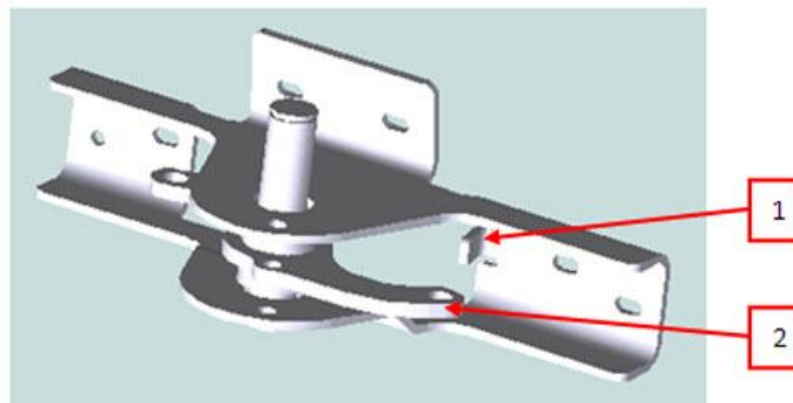

- 1) Base assembly mechanical stop
- 2) "S" Cam

**NOTE:**

If the open or closed position referenced above is not achieved, loosening of the tie-bars or adjustment of the cylinder may be required.

- **Door Closed**

- Adjust aft door tie-bar to position aft door parallel to the upper door casing. Upper door casing seal should be compressed evenly across the aft door surface.
- Adjust forward door tie-bar to position forward door parallel to the upper casing. Upper door casing seal should be compressed evenly across the forward door surface.

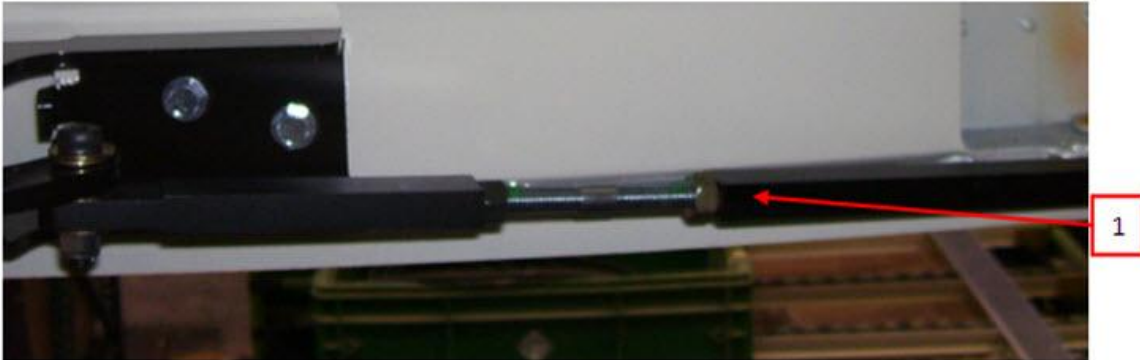

1) Tie-Bar Assembly (Aft Shown)



Upper Door Casing Seal Evenly Compressed

- **Door Open**

- Verify door achieves 85 to 90 degree opening.
- Verify "S" cam is not making hard contact with base assembly mechanical stop.
- Cycle door to confirm open and closed position is repeated and that no air gaps are seen.
- Operation of the door should not result in the air cylinder reaching the end of the cylinder stroke in either the open or closed cycle.
- If the air cylinder is bottomed out in the closed position, the actual force applied to the doors will be reduced. In the open position, the amount of travel can be reduced if the air cylinder has reached full stroke.

- **Air Regulator/Filter Assembly**

- Regulator is factory set at 60 psi. Regulator pressure can be increased between 60 psi to 100% system pressure by adjusting the regulator. In areas with high cross winds, adjusting the regulator to full system pressure will assist in eliminating door flutter and gaps during transport.
- When increasing the air pressure, the open and close speed controls also need to be adjusted to maintain door operating speeds.

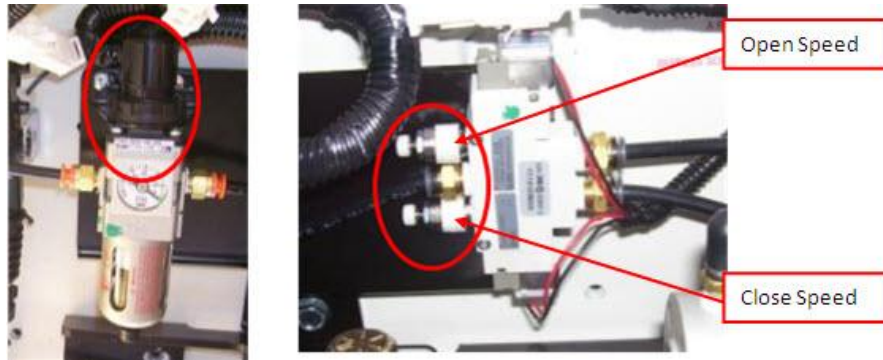

- All air door components are rated to operate within the air system operating pressure.

**NOTE:**

Customer should be informed the regulator gauge is not inoperative when the regulator pressure is increased past the 60 psi setting.

Hide Details

Feedback Information

Viewed: 846  
Helpful: 32  
Not Helpful: 10

No Feedback Found