



Service Bulletin

PRELIMINARY INFORMATION

Subject: Power Steering Gear Leak

Models: 2013 Cadillac XTS

Condition/Concern

Some customers may comment on a fluid leak under the front of the vehicle. Upon further investigation, the technician may find fluid leaking from the power steering system.

Recommendation/Instructions

Power Steering Leak Inspection

1. Start the vehicle and allow the power steering system to reach normal operating temperatures.
Caution: DO NOT hold the steering wheel against the stops to avoid damaging the power steering pump.
2. Turn the steering wheel to the stops in each direction while bumping the steering wheel against the stops 3-4 times. This will build maximum steering system pressure and help identify the source of the leak if a leak is present.
3. Raise and support the vehicle. Refer to Lifting and Jacking the Vehicle in SI.
4. Determine if there is a power steering fluid leak at the power steering gear inlet or outlet pipes.
 - If a leak is not present, lower the vehicle. No further action is required.
 - If a leak is present, replace the power steering gear inlet hose and outlet hose seals. Refer to Seal Replacement for Power Steering Gear Inlet and Outlet Hoses in this bulletin below.

Seal Replacement for Power Steering Gear Inlet and Outlet Hoses

Caution: With wheels of the vehicle facing straight ahead, secure the steering wheel utilizing steering column anti-rotation pin, steering column lock or a strap to prevent rotation. Locking of the steering column will prevent damage and a possible malfunction of the SIR system. The steering wheel must be secured in position before disconnecting the following components:

- The steering column
- The intermediate shaft
- The steering gear

After disconnecting these components, do not rotate the steering wheel or move the front tires and wheels. Failure to follow this procedure may cause the SIR coil assembly to become un-centered and cause possible damage to the SIR coil. If you think the SIR coil has become un-centered refer to your specific SIR coil's centering procedure to re-center the SIR Coil.

1. Lock the steering column in the straight-ahead position using the J-42640 Steering Column Anti-Rotation Pin. For equivalent regional tools refer to Special Tools in SI.
2. Disconnect the intermediate steering shaft from the steering gear. Refer to Intermediate Steering Shaft Replacement in SI.
3. Remove the air cleaner assembly. Refer to Air Cleaner Assembly Replacement in SI.
4. Remove as much power steering fluid from the power steering fluid reservoir as possible.
5. Install the universal engine support fixture. Refer to Engine Support Fixture in SI.
6. Raise and support the vehicle. Refer to Lifting and Jacking the Vehicle in SI.

7. Remove the through bolts for the front and rear transmission mounts. Refer to Transmission Front Mount Replacement and Transmission Rear Mount Replacement in SI.
8. **FOR AWD VEHICLES ONLY:** Remove the propeller shaft. Refer to Propeller Shaft Replacement in SI.
9. Remove the exhaust front pipe. Refer to Exhaust Front Pipe Replacement in SI.
10. Position adjustable jack stands underneath the left and right sides of the rear of the drivetrain and front suspension frame.
11. Lower the vehicle until the drivetrain and front suspension frame is resting lightly on the jack stands.

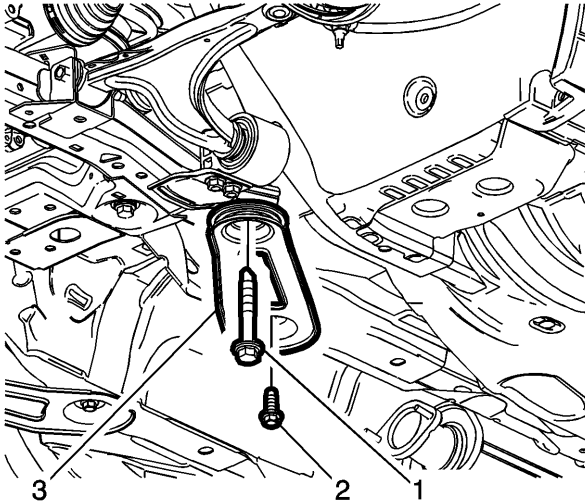

12. Remove the front suspension frame rear bolts (1), reinforcement bolts (2), and reinforcements (3).
13. Loosen the drivetrain and front suspension frame front bolts.
14. Raise the vehicle while the drivetrain and front suspension frame rests on the jack stands. Do not allow the gap between the body and rear the frame to exceed a maximum of 50 mm (2 in).
15. Place drain pans under the vehicle.

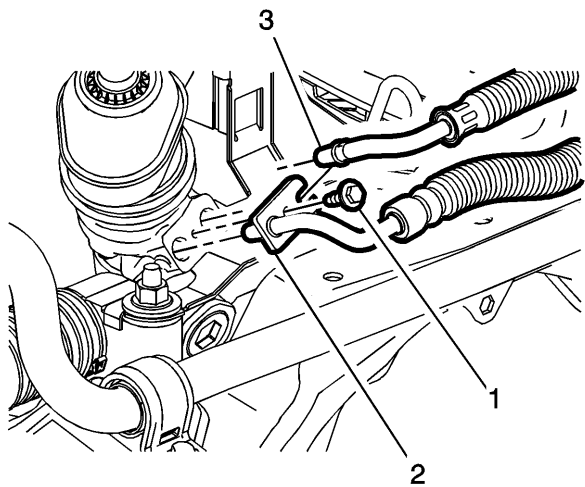

16. Remove the power steering gear inlet and outlet hose bolt (1) and disconnect the power steering gear inlet hose (2) and power steering gear outlet hose (3) from the steering gear.

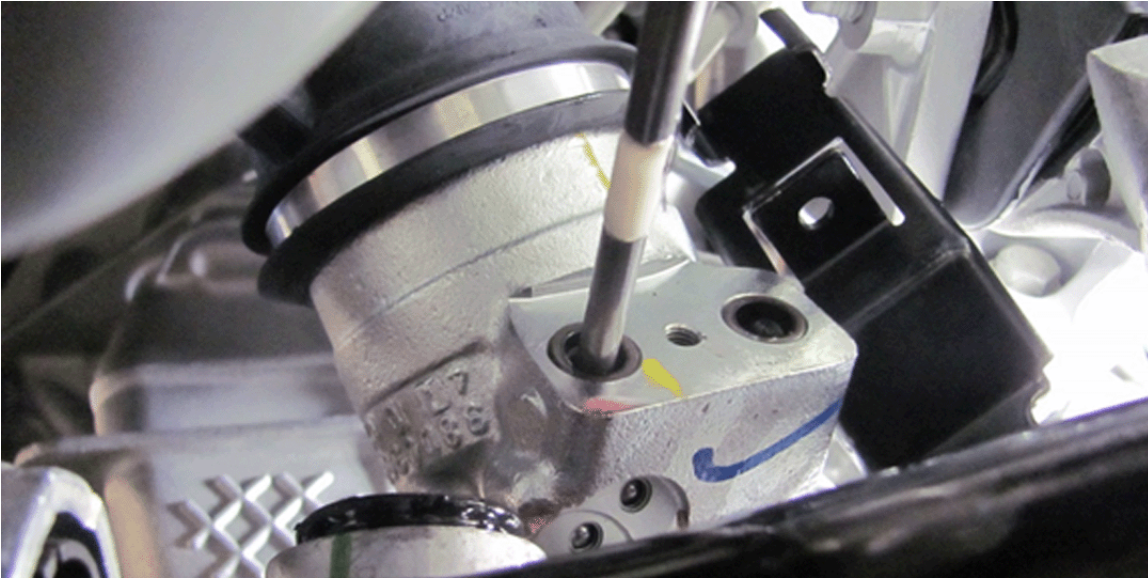

17. Remove the power steering gear inlet and outlet hose seals from the steering gear housing using the J-42640.
18. Install new power steering gear inlet and outlet hose seals into the power steering gear housing using your fingers. Ensure that the seals are installed flush to the housing and not angled in the bore.
19. Connect the power steering gear inlet hose (2) and power steering gear outlet hose (3) to the steering gear.
Caution: Refer to Fastener Caution in SI.
20. Install the power steering gear inlet and outlet hose bolt (1).
Tighten: Tighten the bolt to 9 Y (80 lb in).
21. Tighten the power steering gear inlet hose bolt (1) to 50 Y (37 lb ft).
22. Clean any excess power steering fluid from the vehicle and remove the drain pans.
23. Lower the vehicle until the gap between the frame and body is approximately 12 mm (0.5 in).

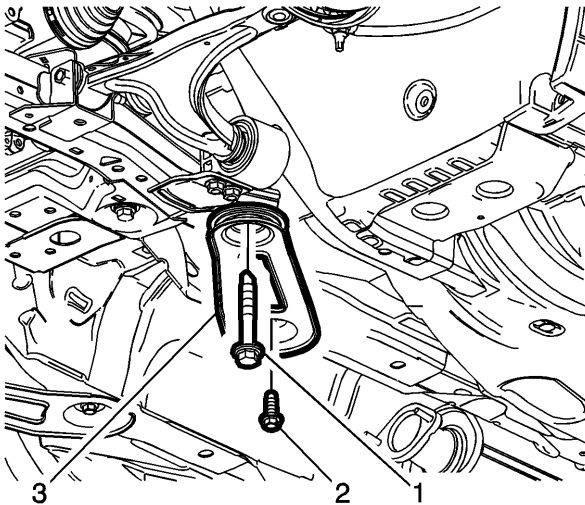

24. Install the front suspension frame reinforcements (3), reinforcement bolts (2), and rear bolts (1).
25. Tighten the front suspension frame rear bolts (1) to 160 Y (118 lb ft).
26. Tighten the front suspension frame reinforcement bolts (2) to 60 Y (44 lb ft).
27. Tighten the drivetrain and front suspension frame front bolts. Refer to Drivetrain and Front Suspension Frame Replacement in SI.
28. Remove the jack stands from the vehicle.
29. Install the exhaust front pipe. Refer to Exhaust Front Pipe Replacement in SI.
30. **FOR AWD VEHICLES ONLY:** Install the propeller shaft. Refer to Propeller Shaft Replacement in SI.

31. Install the through bolts for the front and rear transmission mounts. Refer to Transmission Front Mount Replacement and Transmission Rear Mount Replacement in SI.
32. Remove the universal engine support fixture. Refer to Engine Support Fixture in SI.
33. Install the air cleaner assembly. Refer to Air Cleaner Assembly Replacement in SI.
34. Connect the intermediate steering shaft to the steering gear. Refer to Intermediate Steering Shaft Replacement in SI.
35. Fill and bleed the power steering system. Refer to Power Steering System Bleeding in SI.

Parts Information

Part Number	Description	Quantity
26100863	SEAL, P/S GR INL HOSE	2 (If Req'd)
88861037 (in Canada, 19264717)	FLUID, A/TRANS (DEXRON VI)	2 (If Req'd)

Warranty Information

For vehicles repaired under warranty, use:

Labor Operation	Description	Labor Time
E9539*	Inspect and Replace Inlet & Outlet Pipe/Hose Seals – FWD	2.1 hrs
	Inspect and Replace Inlet & Outlet Pipe/Hose Seals – AWD	2.3 hrs
*This is a unique labor operation for bulletin use only. It will not be published in the Labor Time Guide.		

GM bulletins are intended for use by professional technicians, NOT a "do-it-yourselfer". They are written to inform these technicians of conditions that may occur on some vehicles, or to provide information that could assist in the proper service of a vehicle. Properly trained technicians have the equipment, tools, safety instructions, and know-how to do a job properly and safely. If a condition is described, DO NOT assume that the bulletin applies to your vehicle, or that your vehicle will have that condition. See your GM dealer for information on whether your vehicle may benefit from this information.



WE SUPPORT VOLUNTARY TECHNICIAN CERTIFICATION