



# Service Bulletin

## PRELIMINARY INFORMATION

**Subject:** Diagnosis and Repair HVAC Blower Function

**Models:** 2008-2013 Cadillac Escalade Models  
2007-2013 Chevrolet Silverado  
2008-2013 Chevrolet Suburban, Tahoe  
2007-2013 GMC Sierra  
2008-2013 GMC Yukon Models  
All Built Prior to November 1, 2012

*This PI is being revised to add the 2013 model year and build date information. Please discard PI0695.*

### Condition/Concern

Some customers may comment that the HVAC blower motor is not functioning. They may also comment that there is no air flow from the HVAC vents. This may be an intermittent condition.

One possible cause of this condition may be the contacts in the HVAC junction block(s) located at the right side of the instrument panel.

### Recommendation/Instructions

**Important:** Do Not Replace the HVAC blower motor assembly to correct this condition.

Use the following steps to diagnose the condition and, if necessary, replace the affected connector terminal in the instrument panel junction block.

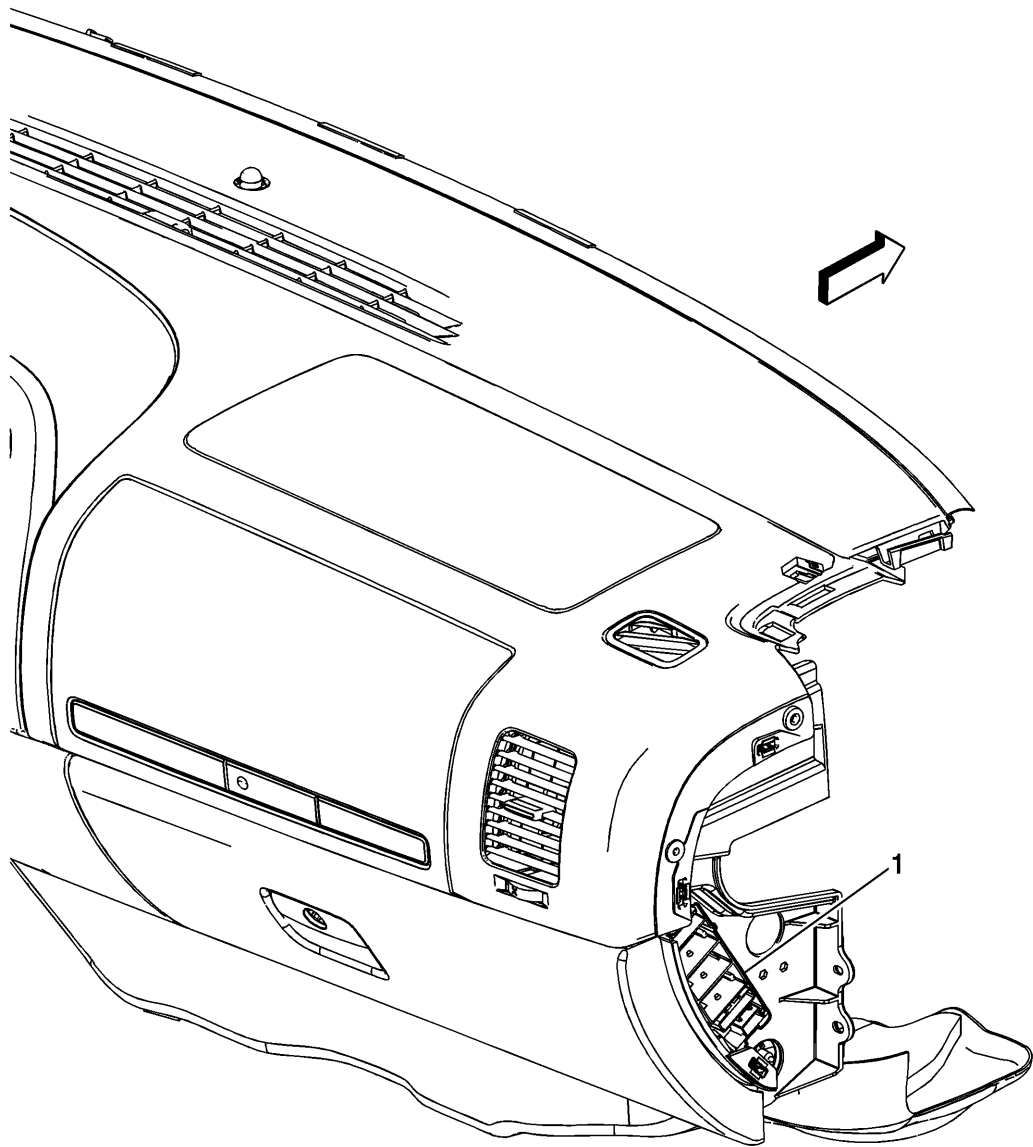

1. Remove the cover on the right side of the instrument panel, exposing the junction blocks.

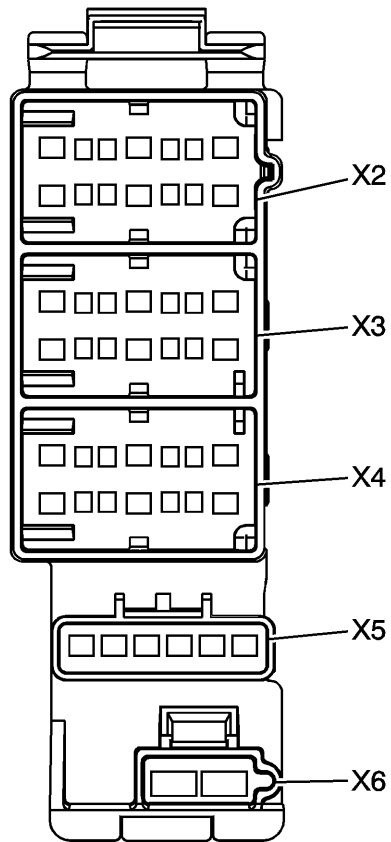

2. Identify Junction Block X4 and X6.
3. With the ignition key in the on position, turn on the HVAC blower and apply light hand pressure to the connectors. Determine if this movement affects the blower operation (intermittent operation).
4. Determine which junction block is affecting the blower operation.

## Junction Block X4 Correction

Use the following diagnostic and repair steps if the fault is determined to be caused by the X4 junction block.

1. Make sure there are no backed out or loose terminals using the appropriate Terminal Test Probe.

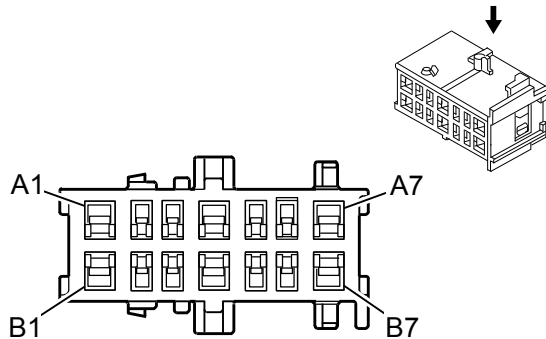

2. Locate Pin A6, Circuit 754.
3. Perform a pin drag test using test probe J-35616-2A (GY).
4. If the terminal fails the pin drag test, replace the terminal for Pin A6. Refer to Junction Block - Right I/P X4 in SI.
5. Cut off the terminal between the core and the insulation crimp to minimize any wire loss.
6. To minimize wire loss, remove only the insulation required.
7. Position the stripped wire in the terminal.

8. Hand crimp the core wings first.
9. Hand crimp the insulation wings around the cable.
10. Solder the hand crimp terminal.

## Junction Block X6 Correction

Use the following diagnostic and repair steps if the fault is determined to be caused by the X6 junction block.

1. Make sure there are no backed out or loose terminals using the appropriate Terminal Test Probe.

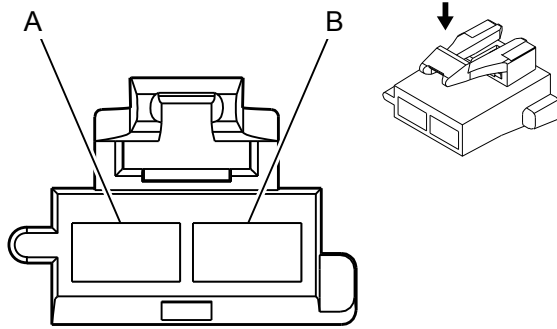

2. Locate Pin A, Circuit 542.
3. Perform a pin drag test using test probe J-35616-42 (RD).
4. If the terminal fails the pin drag test, replace the terminal for Pin A. Refer to Junction Block - Right I/P X6 in SI.
5. Cut off the terminal between the core and the insulation crimp to minimize any wire loss.
6. To minimize wire loss, remove only the insulation required.
7. Position the stripped wire in the terminal.
8. Hand crimp the core wings first.
9. Hand crimp the insulation wings around the cable.
10. Solder the hand crimp terminal.

Reconnect the junction block.

Verify the condition has been corrected.

Reinstall the instrument panel right cover.

## Parts Information

**Note:** Following a warranty repair, all parts are to be turned into the parts department by the technician for tagging, retention and/or return.

Part Number	Description
12191812/19	Junction Block X4–Terminal/Tray
12084590/3	Junction Block X6–Terminal/Tray

## Warranty Information

For vehicles repaired under warranty, and found to have had the above condition, use:

Labor Operation	Description	Labor Time
N9682*	Diagnose/Repair – HVAC Blower Inoperative	0.3 hr
Add	Replace First Junction Block Terminal	0.2 hr

Add	Each Additional Terminal Replacement	0.1 hr
-----	--------------------------------------	--------

\*This is a unique labor operation for bulletin use only. It will not be published in the Labor Time Guide.

**Customer Complaint Code**

Code	Description (Category: 06 Heating/Ventilation/Air Conditioning)
0723	Heating/Ventilation/Air Conditioning - Heater Performance

**Cause Code**

Code	Description (Category: 06 Heating/Ventilation/Air Conditioning)
7083	Wiring/Electrical/Sensors - Poor Contact

GM bulletins are intended for use by professional technicians, NOT a "do-it-yourselfer". They are written to inform these technicians of conditions that may occur on some vehicles, or to provide information that could assist in the proper service of a vehicle. Properly trained technicians have the equipment, tools, safety instructions, and know-how to do a job properly and safely. If a condition is described, DO NOT assume that the bulletin applies to your vehicle, or that your vehicle will have that condition. See your GM dealer for information on whether your vehicle may benefit from this information.



WE SUPPORT VOLUNTARY TECHNICIAN CERTIFICATION