



Service Bulletin

PRELIMINARY INFORMATION

Subject: Navigation Radio Will Not Display Map Data, Message Display is On

Models: 2011 Cadillac Escalade Models
Equipped with Navigation Radio (RPO GMQ)

This PI is being revised to update the Recommendation/Instructions and Parts Information. Please discard PI0504B.

Condition/Concern

Some customers may comment that the navigation radio will not display map data. The following display conditions have been reported:

- Most commonly, the system continuously shows the "Updating in Progress" screen.

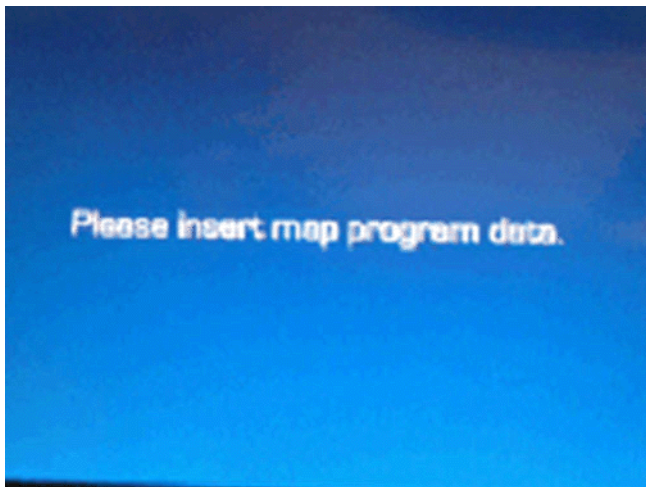

- Another screen that may also be seen is the "Please insert map program data" screen.

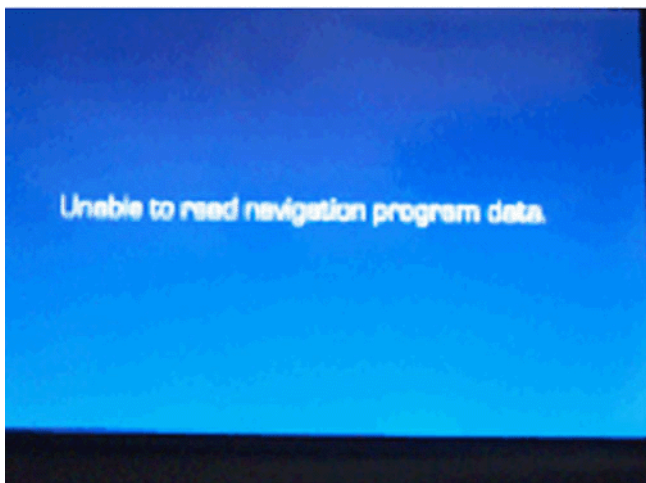

- A final screen sometimes encountered is the “Unable to read navigation program data” screen.

The cause of this condition may be anomalies in the software.

Recommendation/Instructions

Do This	Don't Do This
Install the 2012 MY, (version 2012), or Newer Nav Service Compact Flash Card and load software into the radio.	DO NOT replace the radio.

Install the 2012 MY, (version 2012), or newer, Nav Service Compact Flash Card and load the updated software, following the steps below:

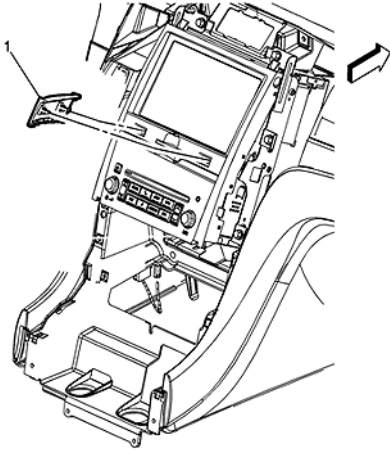

1. Remove the radio faceplate (1) that is located just below the screen. Refer to Navigation Map Interface Module Receptacle Opening Cover Replacement (Cadillac) in SI.



2. With radio powered off, eject the customers Nav compact flash card from the slot in the radio.
3. Insert the GM compact flash card included with the 2012 MY, (version 2012), or newer, GM Service Kit.

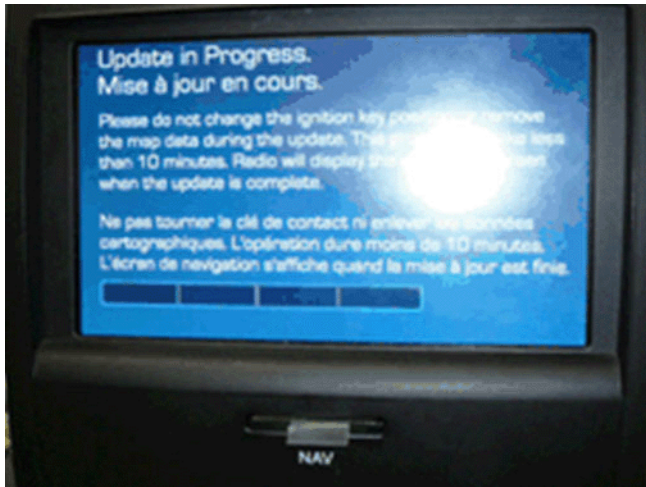

4. Power the radio on. The screen above will appear:



Note: Partial progress is shown in the graphic above.

5. Wait until the progress bar is completely filled.
- It might take about 10 seconds for the progress bar to show up.
 - It might take up to 10 minutes for it to complete.
6. Once reprogramming is completed, the radio will restart and boot up normally.
7. Verify the software by the simultaneous “config” and “seek-up” button press when in FM mode:
- It is accomplished easiest by pressing and holding the “config” button first, then pressing the “seek-up” button.
 - The radio screen may change; just go back to FM mode to view the software. It should read 100B.
 - It may take a few attempts before the software is displayed.



- Once the software installation is verified, reinstall the radio faceplate to complete the installation. Refer to Navigation Map Interface Module Receptacle Opening Cover Replacement (Cadillac) in SI.

Parts Information

Contact the GM Navigation Disc Center toll-free phone number, 1-877-NAV-DISC (1-877-628-3472) or on the web at www.gmnavdisc.com. Press 1 or say "Yes" at the first prompt to order the 2012 MY, (version 2012), or newer, GM Service Kit.

Note: The compact flash card needed to perform the update is included with the Service Kit. The flash card cannot be ordered separately.

Warranty Information

For vehicles repaired under warranty, use:

Labor Operation	Description	Labor Time
R0761	Navigation Map Data Storage Device Replacement	Use Published Labor Operation Time

GM bulletins are intended for use by professional technicians, NOT a "do-it-yourselfer". They are written to inform these technicians of conditions that may occur on some vehicles, or to provide information that could assist in the proper service of a vehicle. Properly trained technicians have the equipment, tools, safety instructions, and know-how to do a job properly and safely. If a condition is described, DO NOT assume that the bulletin applies to your vehicle, or that your vehicle will have that condition. See your GM dealer for information on whether your vehicle may benefit from the information.



WE SUPPORT VOLUNTARY TECHNICIAN CERTIFICATION