



Service Bulletin

PRELIMINARY INFORMATION

Subject: Slip In Forward Ranges Immediately After Replacing The Input Housing - 621 - Check Input Housing - 621 - For Improperly Drilled Feed Holes

Models: 2004-2007 Buick Rainer
1999-2006 Cadillac Escalade, Escalade ESV, Escalade EXT
1999-2006 Chevrolet Avalanche, Express, Silverado, Suburban, Tahoe
1999-2002 Chevrolet Camaro
2002-2007 Chevrolet Trailblazer
2004-2006 Chevrolet SSR
1999-2006 GMC Savana, Sierra, Yukon, Yukon XL
2002-2007 GMC Envoy
2002-2004 Oldsmobile Bravada
1999-2002 Pontiac Firebird
Equipped with 4L60E, 4L65E or 4L70E (RPO M30, M32 or M70) Automatic Transmission and Service Input Housing Part Number 17803687

The following diagnosis might be helpful if the vehicle exhibits the symptom(s) described in this PI.

Condition/Concern

Note: This information only applies to Input Housing (621) with Service Part Number 17803687. This information does not apply to GM Service Transmission Assemblies or to Original Equipment (O.E.) Transmission Assemblies.

A few transmissions may experience a condition of slip or no engagement to any forward gear immediately after replacing the Input Housing (621).

The Input Housing (621) from GM Service Parts may have an incorrectly drilled input shaft.

Air leaking from 3-4 apply hole may be noted when applying air pressure to the forward clutch apply hole during an air check with the Input Housing (621) fully assembled with seals and clutches.

Note: When testing a fully assembled housing, a small amount of air leaking between the input shaft and the housing is not an indicator of a defective part. The press fit between the shaft and housing is designed to contain transmission fluid under pressure but is not air tight.

Recommendation/Instructions

Inspect the 3-4 clutch and the forward clutch oil feed passages for leakage between circuits. Apply regulated compressed air to the 3-4 clutch feed hole and the forward clutch feed hole one at a time with the Input Housing (621) completely assembled. See picture below.

Air should not leak out of the 3-4 clutch feed hole when applying air to the forward clutch feed hole and air should not leak out of the forward clutch feed hole when applying air to the 3-4 clutch feed hole. If air leakage is noted between the two feed holes the Input Housing (621) should be replaced with one from GM Service Parts. (Order new housing part number 19125752.)

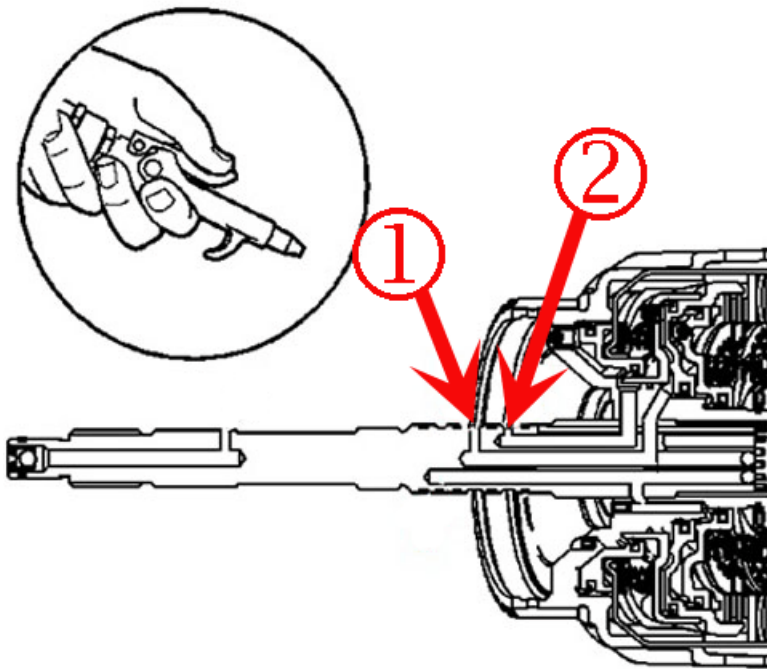

Call out 1: Forward clutch feed hole.

Call out 2: 3-4 clutch feed hole.

Do not replace an Input Housing (621) assembly solely because of a small air leak between the shaft and housing.

Re-use or replace the part based on results of inspection as described in Input Housing and Shaft Assembly Inspection above.

Parts Information

Part Number	Description	QTY
19125752	Input Housing And Turbine Shaft Assembly	1

Warranty Information

For vehicles repaired under warranty use:

Labor Operation	Description	Labor Time
K7251	Input Housing And Turbine Shaft Assembly - Replace	Use Published Labor Operation Time

Please follow this diagnostic or repair process thoroughly and complete each step. If the condition exhibited is resolved without completing every step, the remaining steps do not need to be performed.

GM bulletins are intended for use by professional technicians, NOT a "do-it-yourselfer". They are written to inform these technicians of conditions that may occur on some vehicles, or to provide information that could assist in the proper service of a vehicle. Properly trained technicians have the equipment, tools, safety instructions, and know-how to do a job properly and safely. If a condition is described, DO NOT assume that the bulletin applies to your vehicle, or that your vehicle will have that condition. See your GM dealer for information on whether your vehicle may benefit from the information.



WE SUPPORT VOLUNTARY TECHNICIAN CERTIFICATION