

**LACMTA 45CLFW: Door Mechanism Mounting Bracket
Attachment Repair**



Prepared by: Kalman Takacs
Field Service Engineer
256-241-1243

Approved By: Dan Allen
Chief Engineer

Property and Top Bus Number: LA 45CLFW-03, 95000, 218000, 269000, 286000



Issue: Door mechanism mounting bracket attachment to the sidewall.

Reason/ cause: Still under investigation. Possible contributing factors:

- Improper surface preparation or adhesive application
- Misaligned doors

Solution: On an as-needed basis, prepare and reinstall bracket per this work instruction (SOI).

LACMTA 45CLFW: Door Mechanism Mounting Bracket Attachment Repair



Number of affected buses: as required

Estimate repair hours/bus: 8 hours

Necessary parts:

Bracket, entrance door,	NABI Part #: 802-4055-903 ,	as required,
Bracket, exit door,	NABI Part #: 802-4055-904 ,	as required,
PC-120, primer,	NABI Part #: 5016117 ,	as required,
Plexus AO-420, adhesive,	NABI Part #: 5016116 ,	1 tube / bracket,
or		
Plexus MA-425, adhesive,	NABI Part #: 5016135 ,	1 tube / bracket,
Screw, #10x1, sheet, PH, SS,	NABI Part #: 270116 ,	3 / bracket

Necessary tools:

Regular hand tools (sockets, wrenches, screwdrivers, etc.), drill, angle grinder, 24G or 36G abrasive disc, Plexus gun – air operated, brush, rag, acetylene torch (in case the bracket is not completely separated), Sharpie marker pen

LACMTA 45CLFW: Door Mechanism Mounting Bracket Attachment Repair



SAFETY PRECAUTIONS MUST BE FOLLOWED ACCORDING TO ACCEPTED INDUSTRY STANDARDS AND LOCAL/PROPERTY REQUIREMENTS.

Note: this work instruction applies on both the front (entrance) and the rear (exit) doors.

1. Park the bus and apply the parking brake.
2. Turn off main battery disconnect switch.
3. Drain the air from the passenger door so the door panels can be moved freely.
4. Remove door mechanism assembly, door panels and door shafts. Refer to Maintenance Manual.
5. Remove mounting bracket. If the bracket has not completely separated than heat up the bracket and use pry bar to separate it from the bus structure. **Do not damage the composite bus structure.** Follow local safety requirements. Have a fire extinguisher be available.
6. Remove any adhesive traces from the mounting bracket.

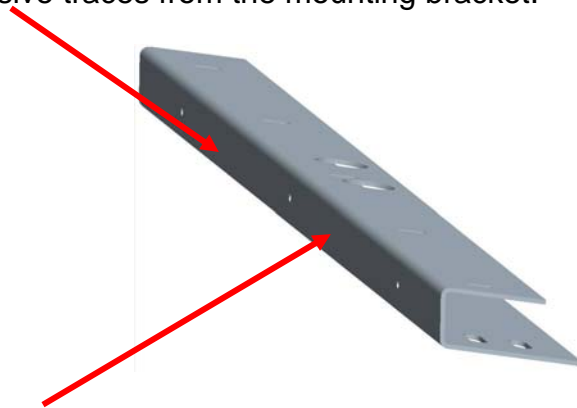

7. Grind the entire back surface of the mounting bracket (where it will be attached to the composite structure) with 24G or 36G abrasive disc. Abrasive blasting (sand blasting) cleaning process also can be used if equipment is available. The below pictures of sample plates show what kind of quality must be achieved with the surface preparation.

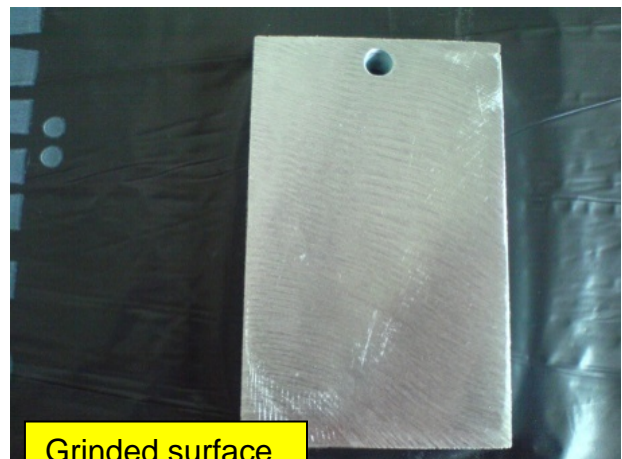
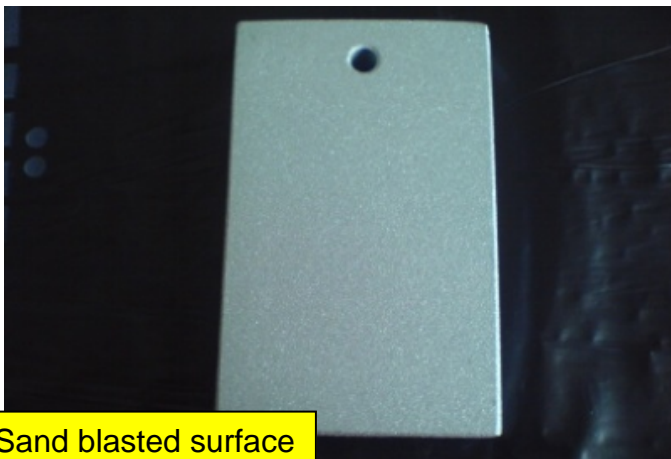

LACMTA 45CLFW: Door Mechanism Mounting Bracket Attachment Repair



8. Drill new 3/16" size holes 1" from the original holes. These holes are for the new sheet metal screws. These sheet metal screws will keep the bracket in place while the adhesive cures. Remove burr around the new holes.
9. Degrease back surface with acetone.
10. Apply PC-120 primer. Refer to **SB-11-04-01**.



NABI Service Bulletin: SB-11-04-01

To: Bus Operations Managers, Bus Maintenance Managers and Bus Maintenance Personnel
 From: Kalman Takacs - Field Service Engineer
 Subject: Using Plexus Adhesives on Compo Buses
 Date Issued: September 26, 2011

First page of the NABI Service Bulletin is shown. This document has 2 pages

This Service Bulletin provides information about the Plexus adhesives used on NABI CLFW Compo buses.

NABI using the following Plexus adhesive products:

Name	Tensile strength, (psi)	Working Time (min)	Operating temp (F)	Gap Filling (inch)
A0420	2700-3000	4-6	-67 to 250	to .375
MA310	4000-4500	1.5-10	-67 to 250	to .125
MA425	2000-2500	20-30	-67 to 250	to .375
PC-120, primer,		NABI Part #: 5016117,		Metal primer / conditional designed for aluminum and stainless steel.
Plexus A0-420, adhesive,		NABI Part #: 5016116,		Perfect for all thermoplastic and steel parts.
Plexus MA-310, adhesive,		NABI Part #: 5016110,		High strength adhesive, especially recommended for bonding ABS, PVC, FRP, Urethanes, Epoxies, Vinyl Esters, Acrylics.
Plexus MA-425, adhesive,		NABI Part #: 5016135,		Use when extended working time is required (large parts)

General rules about using Plexus adhesives:

1. Use only aluminum or stainless steel material for steel parts with Plexus. Read Technical Data Sheets (TDS) of the adhesives about other useable materials like fiberglass, ABS, PVC, FRP, etc.
2. Make surface of the steel (or other material) part rough by using Scotch Brite wheels or 80G abrasive discs.
3. Sand the composite surfaces (bus structure) with 36G abrasive disc. Remove paint, gel-coat and any loose material (like separated fiberglass layers, etc.) *Wear respirator and safety goggles!*
4. Remove dust and clean the surfaces with isopropyl alcohol.
5. Apply PC-120 primer to the steel part where the adhesive will be added. Some important details:
 - Do not use too much PC-120, only a thin layer is needed.
 - Use a clean rag to wipe PC-120 off before it completely dries to remove surface contaminants it has cleaned
 - Check the lot number for the date to make sure the PC-120 is less than a year old.
 - Read the instructions written on the bottle for more details about application and drying time.
6. Apply Plexus adhesive suitable for the job to the part and install it according to the engineering drawing. Place small washers or 0.035 welding wire pieces underneath the bracket to provide a min thickness for the adhesive. These spacers will remain between the part and the composite surface.

SOP-19-07

Revision: Initial

LACMTA 45CLFW: Door Mechanism Mounting Bracket Attachment Repair



11. While the PC-120 primer dries, clean the composite structure: remove old adhesive and scuff the surface gently with 24G or 36G abrasive disc. **Do not cut the fiberglass/carbon fiber layers!** Just make the surface rough so the adhesive will bound better.



12. Degrease composite surface with acetone.

13. Mark the location of the bracket on the composite surface. See drawings below.

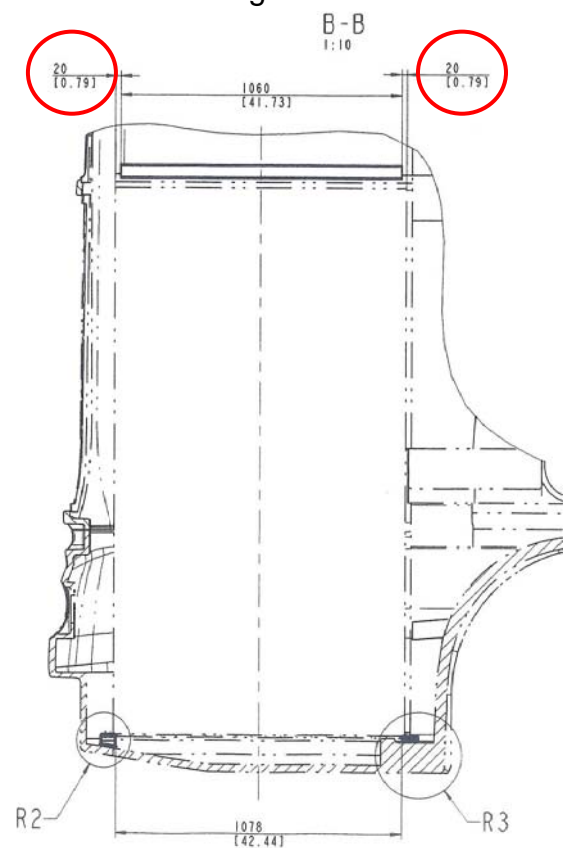
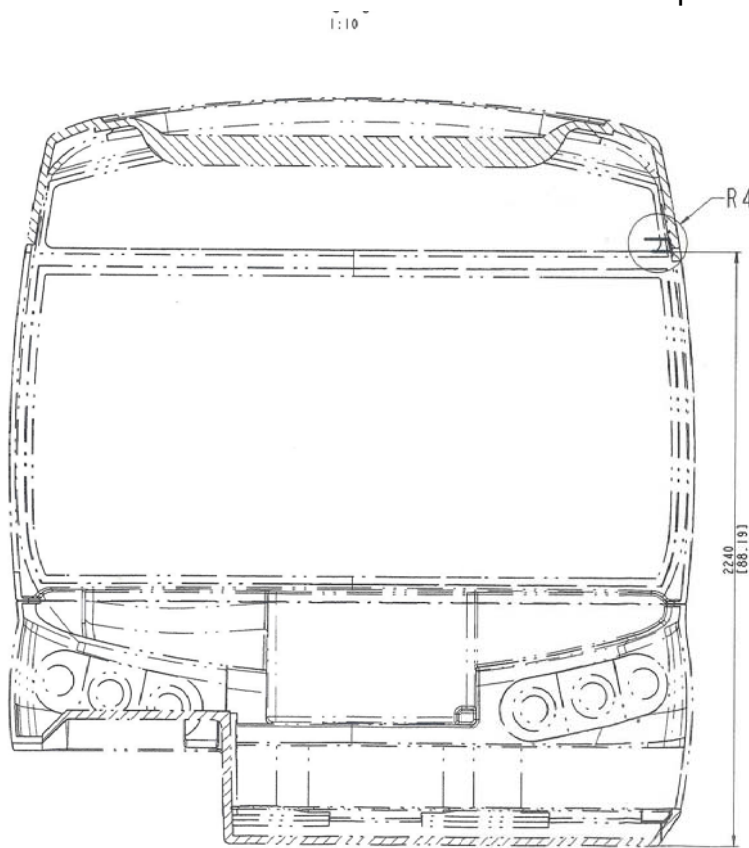

LACMTA 45CLFW: Door Mechanism Mounting Bracket Attachment Repair

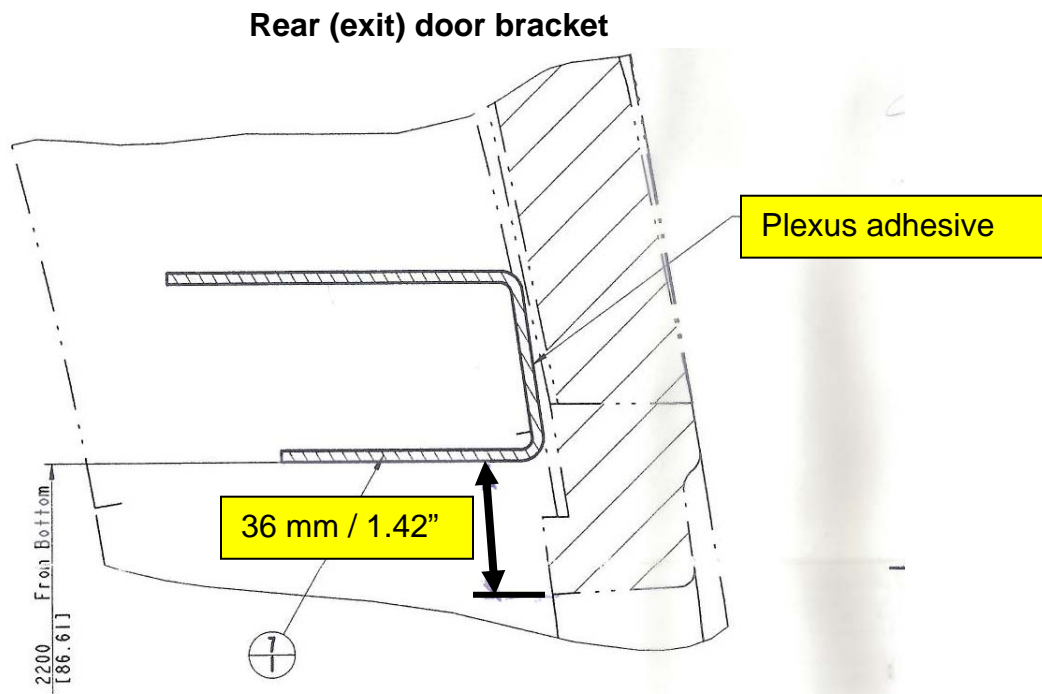
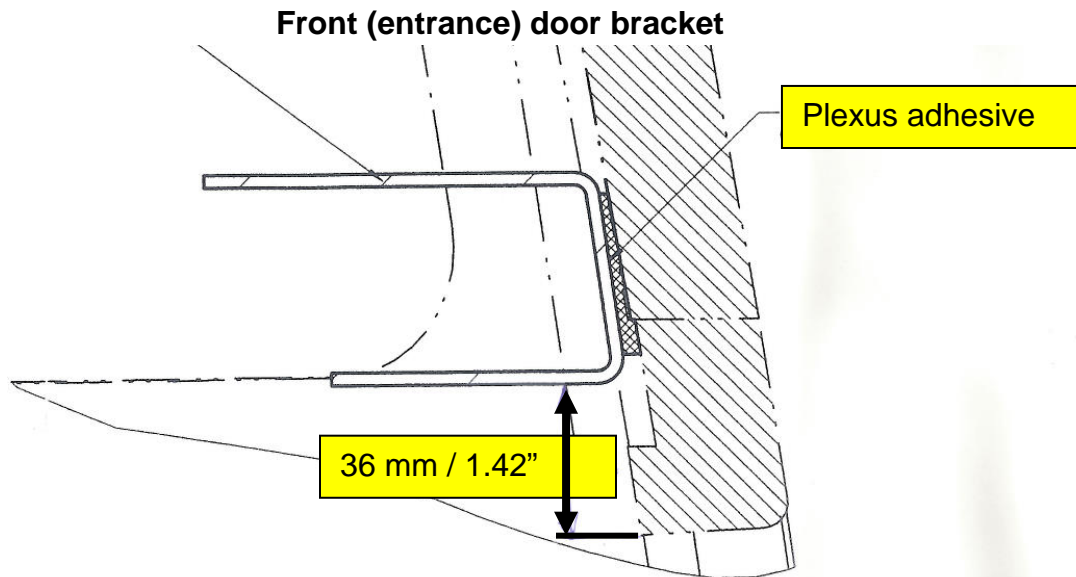

LACMTA 45CLFW: Door Mechanism Mounting Bracket Attachment Repair



14. Place the bracket to the composite structure and check the gaps around the edges. Notice the area where the gap is larger and ensure that these areas will be covered with the correct amount of adhesive (see next step).
15. Apply a continuous bead of AO-420 or MA-425 Plexus adhesive to the prepared surface of the bracket. Ensure to use the correct MC 10-24 mixing tube and applicator (gun) for the Plexus adhesive. It is recommended to use air operated gun that would allow faster application. See picture below how to cut the end of the mixing tube. Ensure that the two components of the adhesive are mixing well (they are different colors for easy identification). The entire surface has to be covered with adhesive. Apply more adhesive to those areas where larger gaps were noticed. **Note: the AO-420 adhesive has a very short working time. The bracket has to be in place within 4 minutes after the plexus adhesive application was started on the bracket.**

MC 10-24 mixing tube for Plexus adhesive



Cutting the Plexus mixing tube

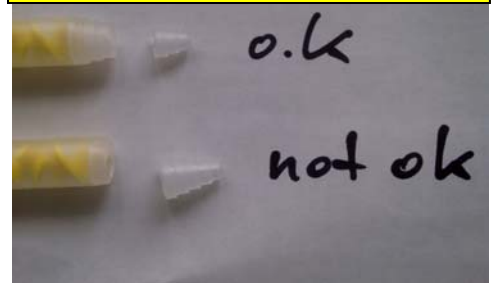

Plexus applicator with 380 ml (13 oz.) adhesive tube



Plexus application on a sample surface and not on the actual Vapor bracket

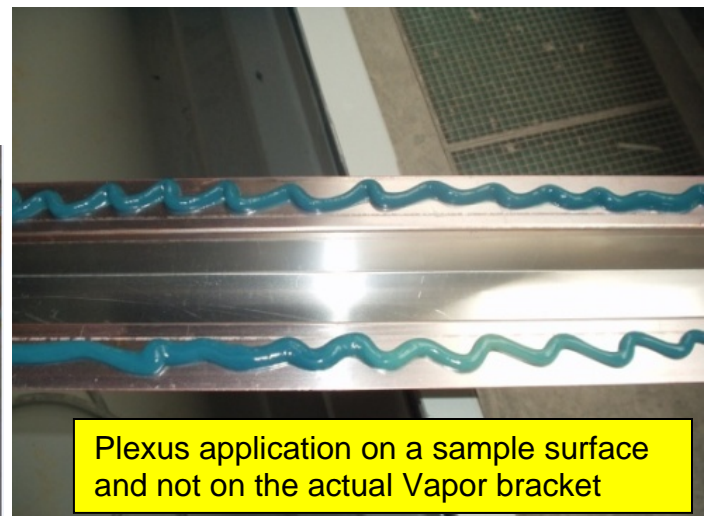

16. Place ¼" size flat washers on the bracket, over the new holes. These washers will provide the required gap between the bracket and the composite structure. The min. required gap is 2-3 mm.

LACMTA 45CLFW: Door Mechanism Mounting Bracket Attachment Repair



17. Push the bracket against the composite structure. Have a helper who can install the sheet metal screws. Refer to **SB-11-04-01**. The adhesive has to squeeze all the way around from underneath the bracket and through the holes of the original sheet metal screws. This will indicate that the correct amount of adhesive was applied and it fills the gap between the bracket and the composite structure. Remove excess adhesive all around the perimeter of bracket and around the holes.
18. Let the Plexus cure for 1 hour. Do not install door parts nor move the bus during this time.
19. Reinstall removed door components. Refer to NABI Maintenance Manual.
20. Adjust the door per Maintenance Manual. ***The correct adjustment is critical: out of adjustment may overload certain door components and may cause improper door operation.***
21. Remove all the tools from work area.
22. Check for completeness of work.
23. Turn the main battery disconnect switch(es) on.
24. Start the bus and make sure that the doors are working correctly.
25. Record bus number, date of repair and name of technician who completed the work.