

## New Jersey Transit: Fan Support Bracket Repair



**Prepared by:** Kalman Takacs  
Field Service Engineer  
256-241-1243

**Approved By:** Dan Allen  
Chief Engineer

**Property and Top Bus Number:** New Jersey Transit 416.15, 164200, 164400, 279000, 279500, 289000



**Issue:** Cracks at the fan support bracket area.

**Reason/ cause:** NABI updated the structure to enhance the durability.

**Solution:** Repair cracks and add reinforcement parts per this work instruction (SOI).

# New Jersey Transit: Fan Support Bracket Repair



**Number of affected buses:** 859  
**Estimate repair hours/bus:** 6 hours

## Necessary parts:

PLATE BACKING, Curb Side,	Part #: <b>10C-1301-221,</b>	1 / bus,
PLATE BACKING, Street Side,	Part #: <b>10C-1301-223,</b>	1 / bus,
PLATE TIE, Curb Side,	Part #: <b>10C-1301-224,</b>	1 / bus,
PLATE TIE, Street Side,	Part #: <b>10C-1301-226,</b>	1 / bus,
TUBE Reinforcement, Fan mount,	Part #: <b>10C-1301-410,</b>	2 / bus,
SUPPORT GUSSET,	Part #: <b>10C-1301-207,</b>	2 / bus
BRACE REMOVABLE WELDMENT, powder coated,	Part #: <b>10C-1301-240,</b>	1 / bus,
Slotted bar, 90, 1 x 3 slots,	Part #: <b>5015886,</b>	1 / bus,
1/4"-20x1" ZINC-PLATED HHCS,	Part #: <b>220420088,</b>	2 / bus,
1/4" ZINC-PLATED LOCK WASHER,	Part #: <b>2504,</b>	2 / bus,
Masking tape, 2" wide,	Part #: <b>NPN,</b>	as required,
Industrial primer,	Part #: <b>NPN,</b>	1 can
Rubberized undercoating,	Part #: <b>NPN,</b>	1 can
Penetrate test kit (cleaner-, penetrate- and developer sprays):	Part #: <b>NPN,</b>	as required,
Wire tie, 14", Aqua, Hi temp,	Part #: <b>5001036,</b>	10 / bus,

See some pictures below about the possible usable products.



## Necessary tools:

Basic hand tools, drill, 1/8" drill bit, angle drill, brush, 80G abrasive disc, air grinder, belt sander, rags, Electric grinder with 1/16" thick cut off and grinding wheels suitable for stainless steel material, GMAW welder (Welding process: 135 (EN ISO 4063, Gas Metal Arc Welding process)) with 308LSi .035 welding wire and shielding gas (see WPS sheets for details)

# New Jersey Transit: Fan Support Bracket Repair



## **SAFETY PRECAUTIONS MUST BE FOLLOWED ACCORDING TO ACCEPTED INDUSTRY STANDARDS AND LOCAL/PROPERTY REQUIREMENTS.**

1. Start the bus and check the driver's display: the Park Brake, Speed Switch and sometimes the Proheat lights should be on. If there are other warning lights on (check engine, transmission, etc.) then notify the superintendent of the garage before starting any repair. It is important to document any electrical issues prior the repair because after the repair is completed the bus has to be in the same condition.



2. Park the bus and apply the parking brake.
3. Turn off main battery disconnect switch(es).
4. Tag and disconnect batteries cables.
5. Disconnect the ECU of engine, transmission and ABS. Disconnect the destination signs. Turn off and disconnect the PA system. Open the light panels and disconnect all the IO modules.  
**Disconnect the 2 way weather pack connector at the fire suppression bottle, located at the street side (SS) in front of the rear axle.** See some example pictures on the next page.

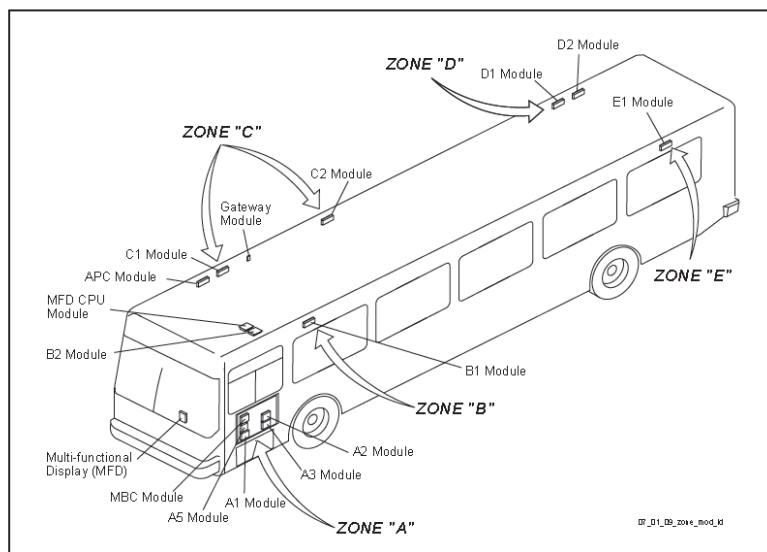
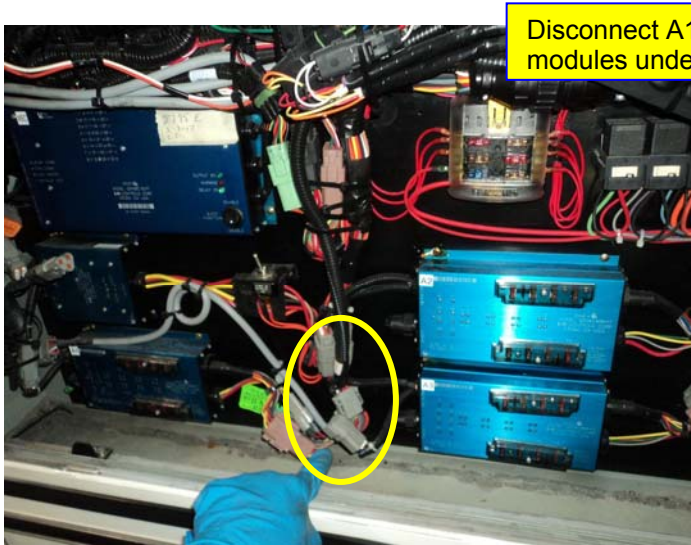

Figure 1- Zone and Module Identification

# New Jersey Transit: Fan Support Bracket Repair



Disconnect A1, A2, A3 and MBC modules underneath the driver's window



Disconnect the clever device behind the front SS seats

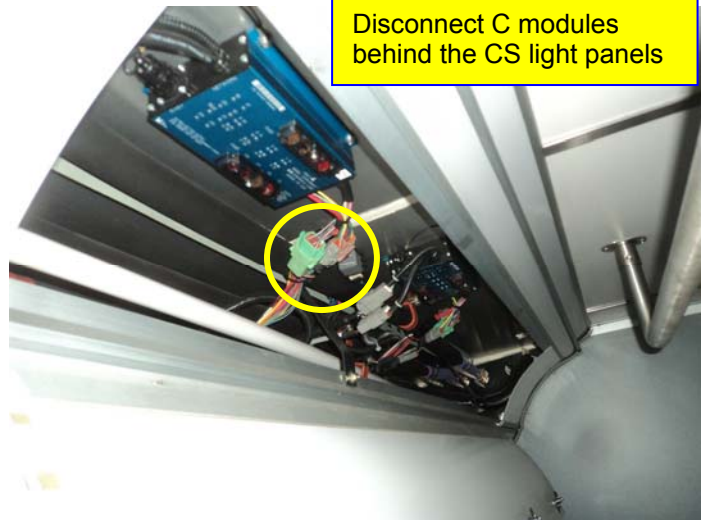

Disconnect C modules behind the CS light panels

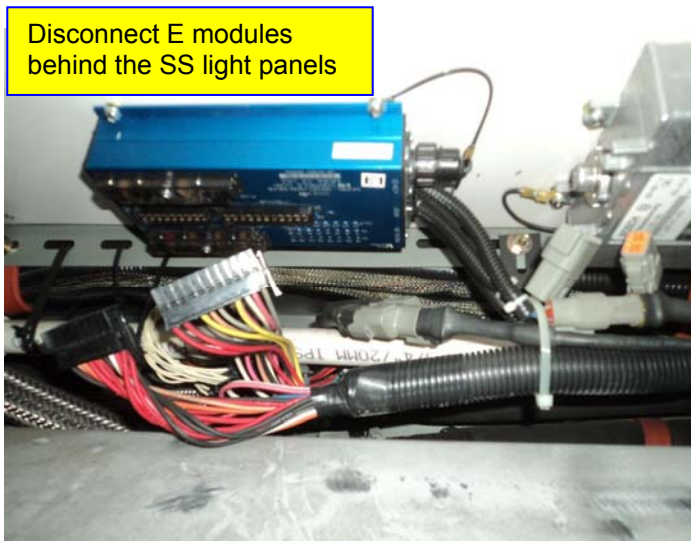

Disconnect E modules behind the SS light panels



Disconnect transmission ECU behind the SS rear light panel (or above the transmission)

## New Jersey Transit: Fan Support Bracket Repair



6. Open the rear engine and the attic compartment doors.

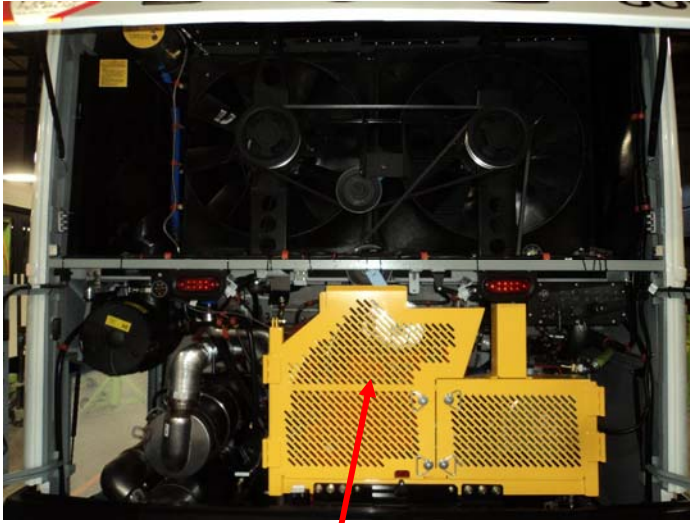

7. Remove belt guard and its mounting brackets.

8. Remove curb side (CS) tail light.

9. Remove both the street side (SS) and CS fire suppression nozzles.

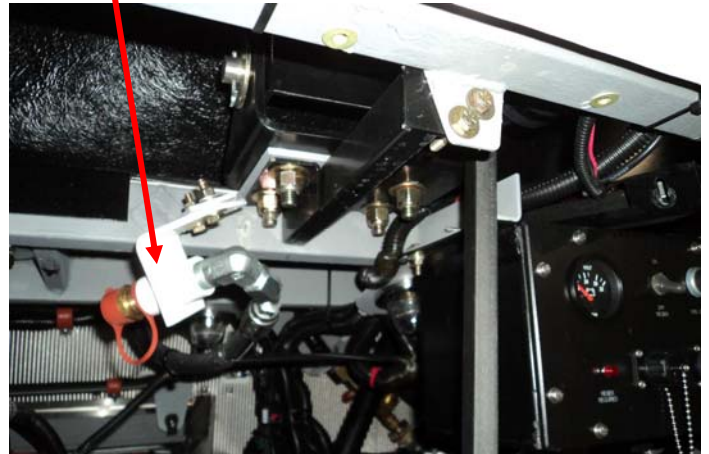

## New Jersey Transit: Fan Support Bracket Repair



10. Remove rear engine control box and tape the electrical connectors.

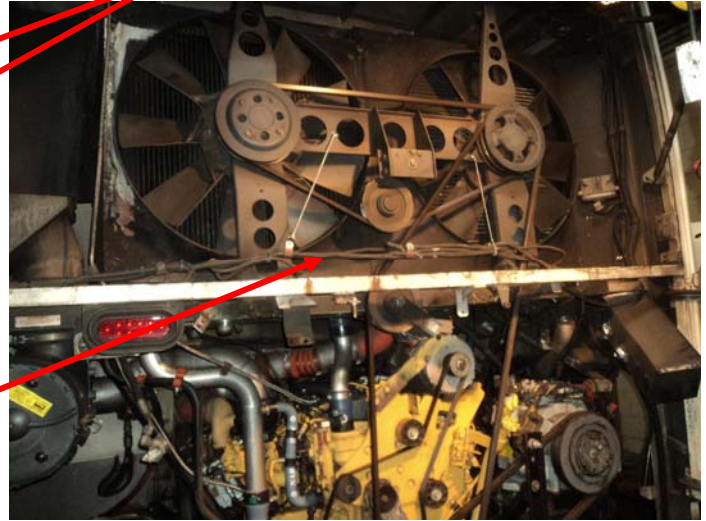
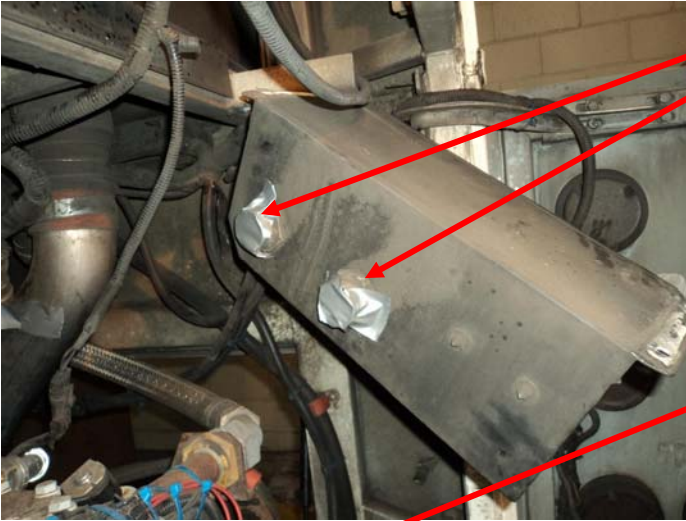

11. Remove electrical harnesses as required. Protect them with fireproof blankets.



12. Cover the engine and other surrounding components in order to protect them from damage caused by grinding sparks and welding splatters. Must use fire proof blankets and shields as required. Cover the engine doors also.
13. Mark structure where the reinforcement parts will be installed and remove paint by using scrapers and 80G abrasive disc.
14. On buses equipped with CAT and 2007 Cummins engines, cut the inner mounting bracket of the control box.

## New Jersey Transit: Fan Support Bracket Repair



15. Cut the CS fire suppression nozzle mounting bracket (slotted bar) off.

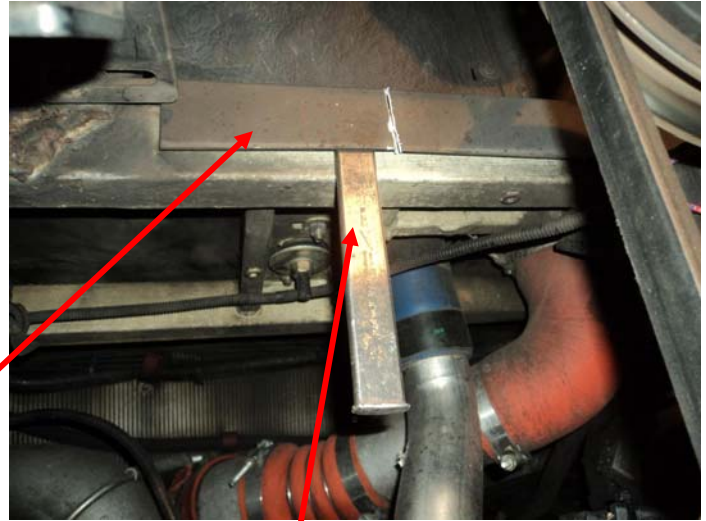
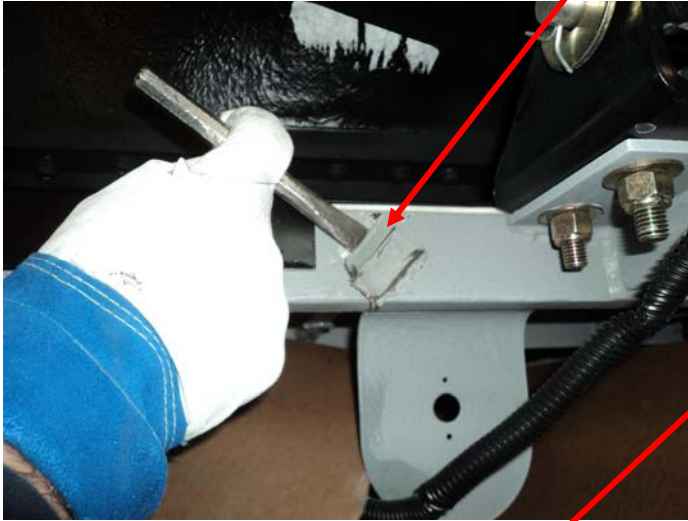

16. Mark and cut the aluminum closeout panel above the structure. Pry the panel away from the structure to provide clearance for the cutting wheel. **Do not hurt the structure!**

17. Check for cracks around the fan support bracket. Use magnifying glass and/or penetrant test to identify cracks.

18. If crack was found then:

- Find the end of the crack,
- Drill a 1/8" size hole at the end of the crack,



- Bevel the crack profile 2x30° for single V-groove weld,
- Clean the surface in the welding area (mechanical cleaning).

## New Jersey Transit: Fan Support Bracket Repair



- Degrease surfaces.
- Fix the tube the right position, use hydraulic ram (or mechanical clamp). This step will reduce the residual stress after welding, which means higher service life.
- Weld the crack according to WPS No. **WPS 35/40LFW-R03**.
- Check the welds by Visual Test and/or Penetrate Test.

# New Jersey Transit: Fan Support Bracket Repair



19. Install SS backing plate P/N **10C-1301-221** and CS backing plate P/N **10C-1301-223**:

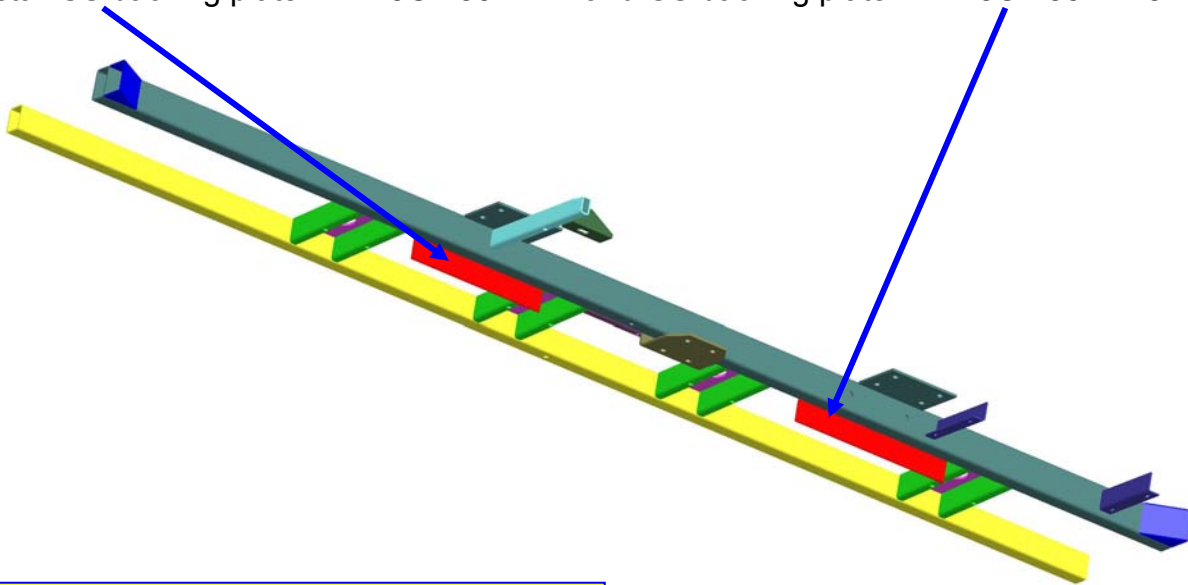

Notch the CS backing plate (PN **10C-1301-223**) as picture shows below. It is necessary to provide clearance around the threaded stud of the temperature sensor (see picture below)



## New Jersey Transit: Fan Support Bracket Repair



- Position plates as drawing shows below. Make sure the backing plates are hanging below the cross-member at least 1-3/4"

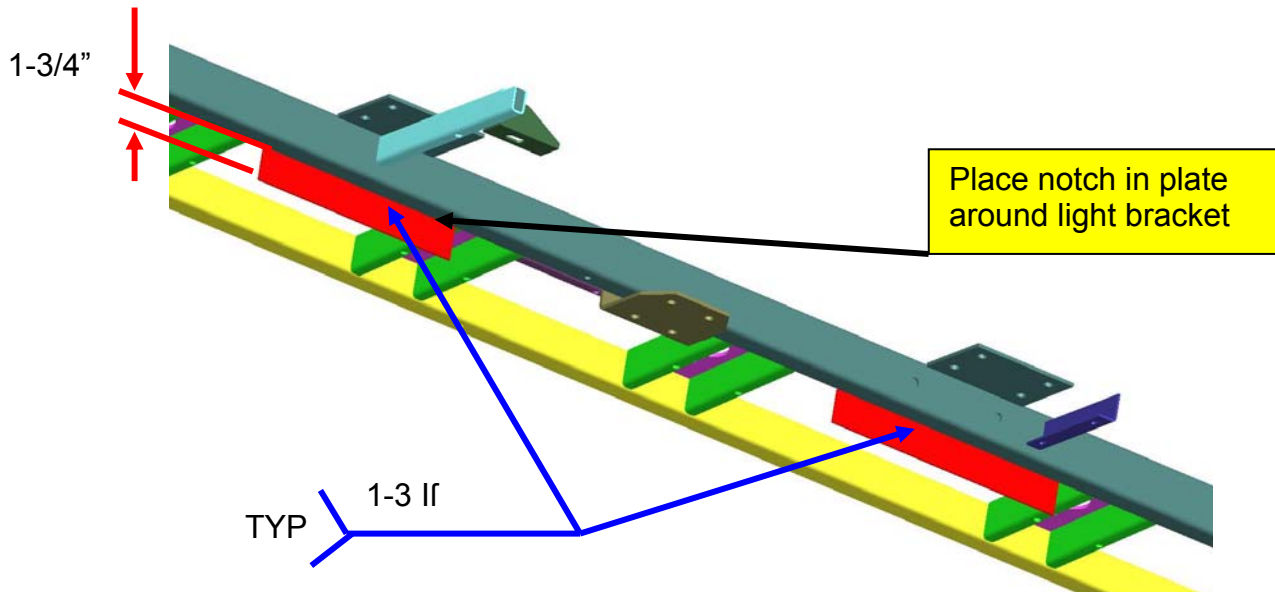

- Weld at interface between back corner of tube and backing plate. Weld is stitch weld, 1-3 (1" long weld and 3" between the centers of the welds) per **WPS 35/40LFW-R01**.



- Grind weld smooth so the next part will fit correctly.

## New Jersey Transit: Fan Support Bracket Repair



### 20. Install CS and SS reinforcement tubes P/N 10C-1301-410:

- Install reinforcement tubes below the fan drive support. Center the tube on the structure. Grind welds as needed for a flush mount fit.

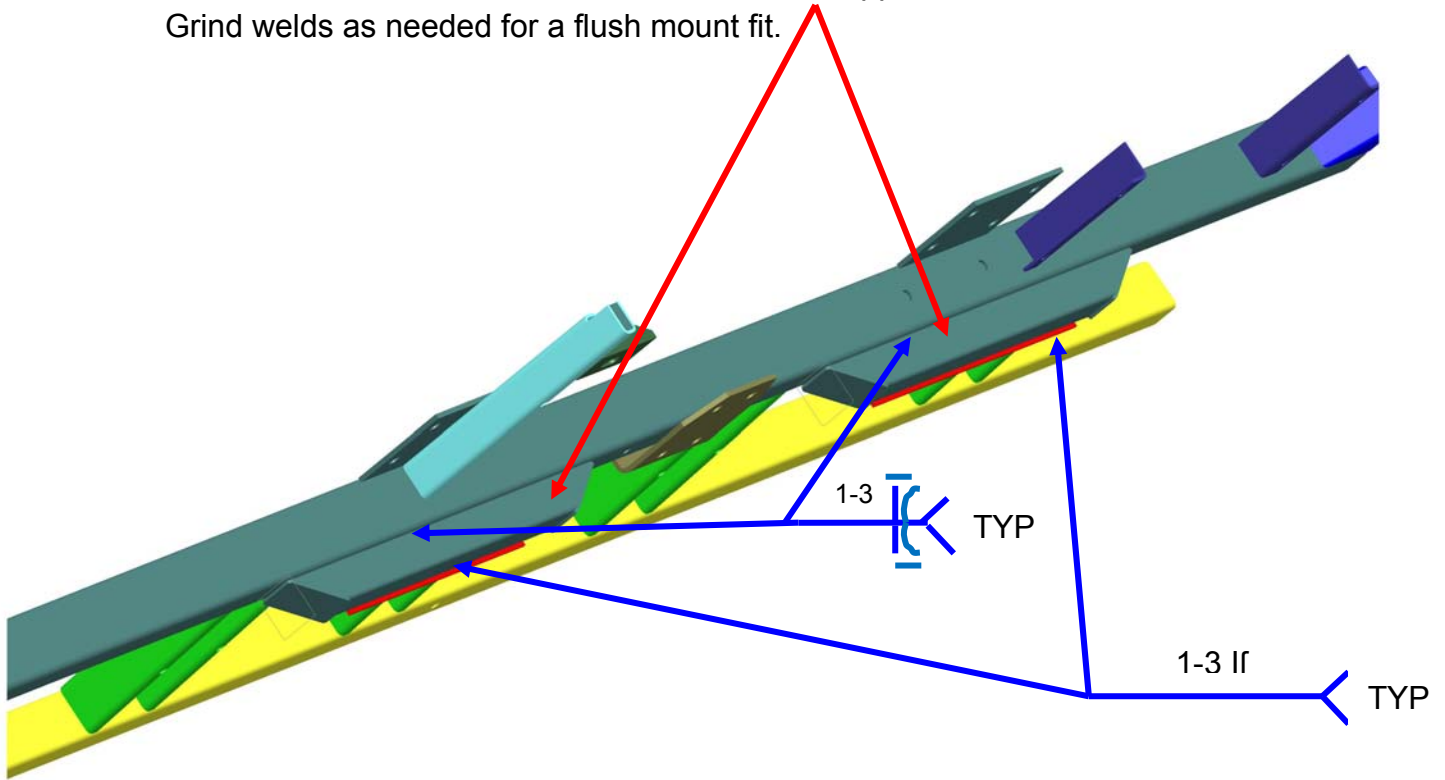

- Weld the corner between the cross-member and the support tube and also weld between the support tube and the backing plate. Weld is 1-3. **WPS 35/40LFW-R01**.



- Grind weld smooth so the next part will fit correctly.

## New Jersey Transit: Fan Support Bracket Repair



21. Install CS and SS tie plates P/N **10C-1301-224** and **10C-1301-226**:

- Position plates as picture shows below.

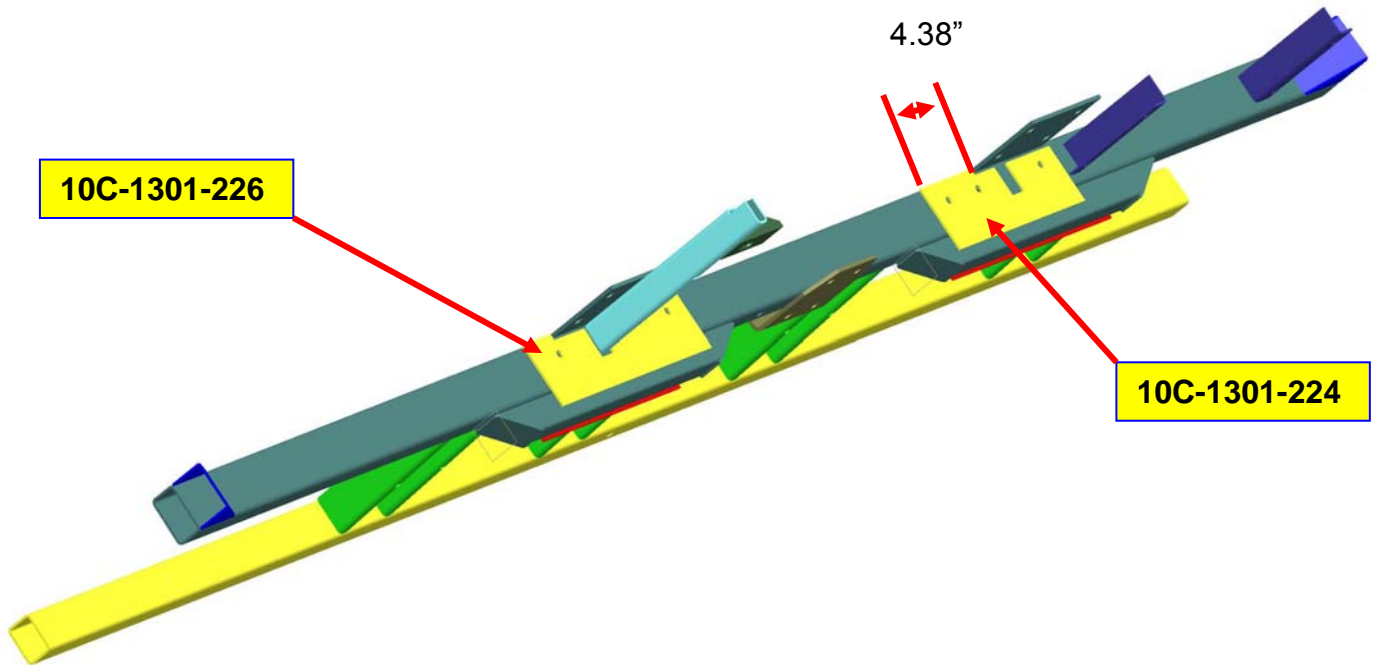

- Weld along bottom edge with 1-3 stitch, weld sides solid and weld top with 1-3 stitch welds. Weld solid at cutout around brace. Weld 3 plug welds at the holes. Welds per **WPS 35/40LFW-R02**.
- Grind welds as required.

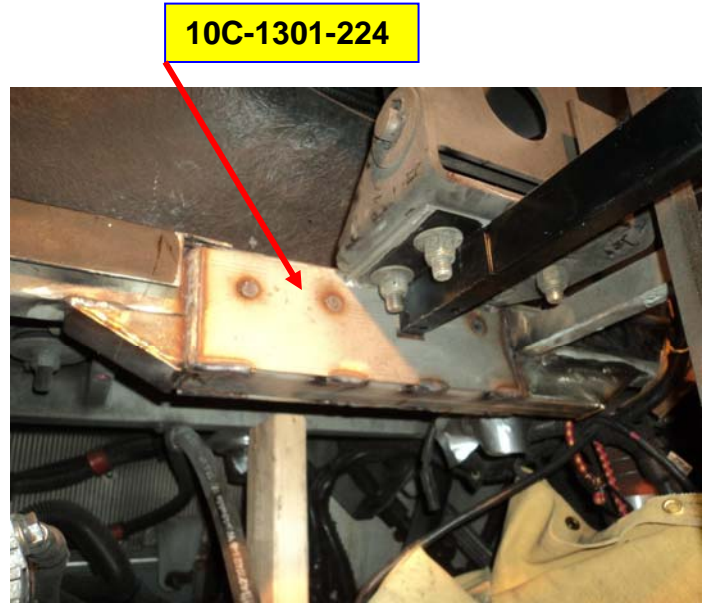

## New Jersey Transit: Fan Support Bracket Repair



### 22. Install CS removable brace P/N **10C-1301-240**:

- Install removable brace P/N 10C-1301-240 and CS support gusset P/N 10C-1301-207 with ¼-20 bolts. This way the support gusset will be positioned correctly. Tack weld the support gusset to the tie plate then remove the brace so the gusset can be welded.

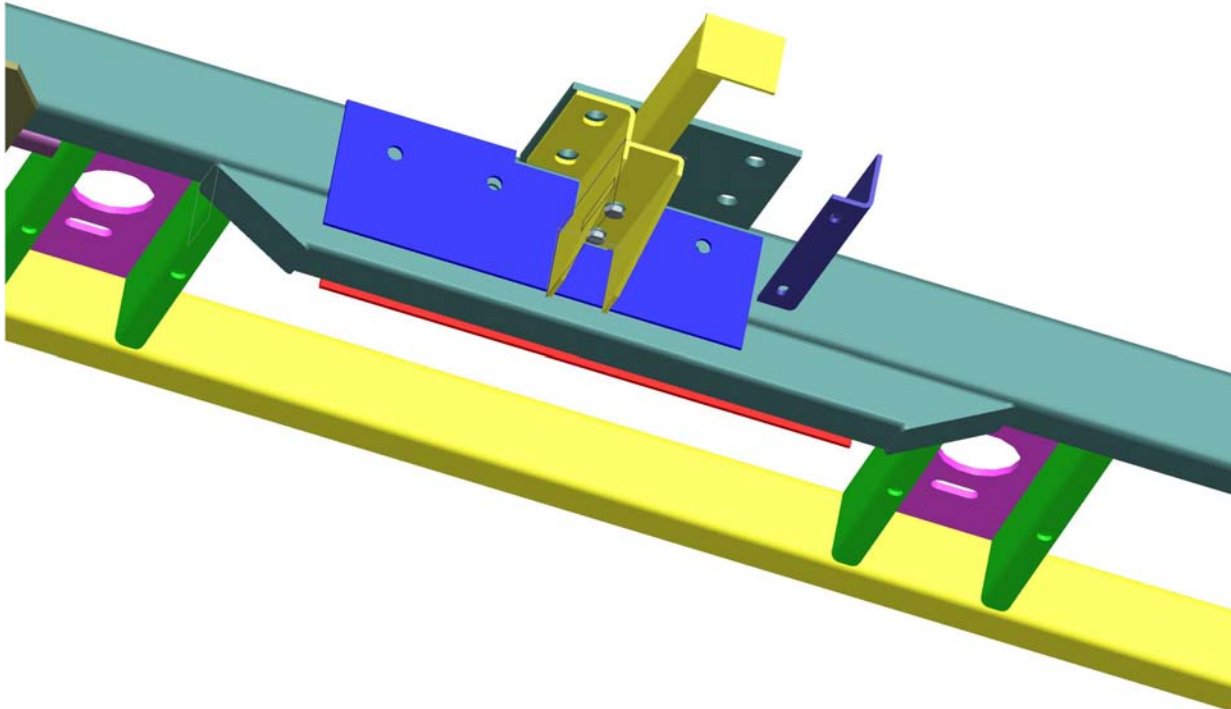

- **Note:** buses equipped with CAT and 2007 Cummins engines, the brace is not removable. Cut 1.5" off from the end of support bracket (see below) to provide clearance for the snuber bracket then weld the support gusset underneath the original brace (see next paragraph about welding instructions).



## New Jersey Transit: Fan Support Bracket Repair



23. Install CS and SS support gussets P/N 10C-1301-207:

- Position support gussets as picture shows below.

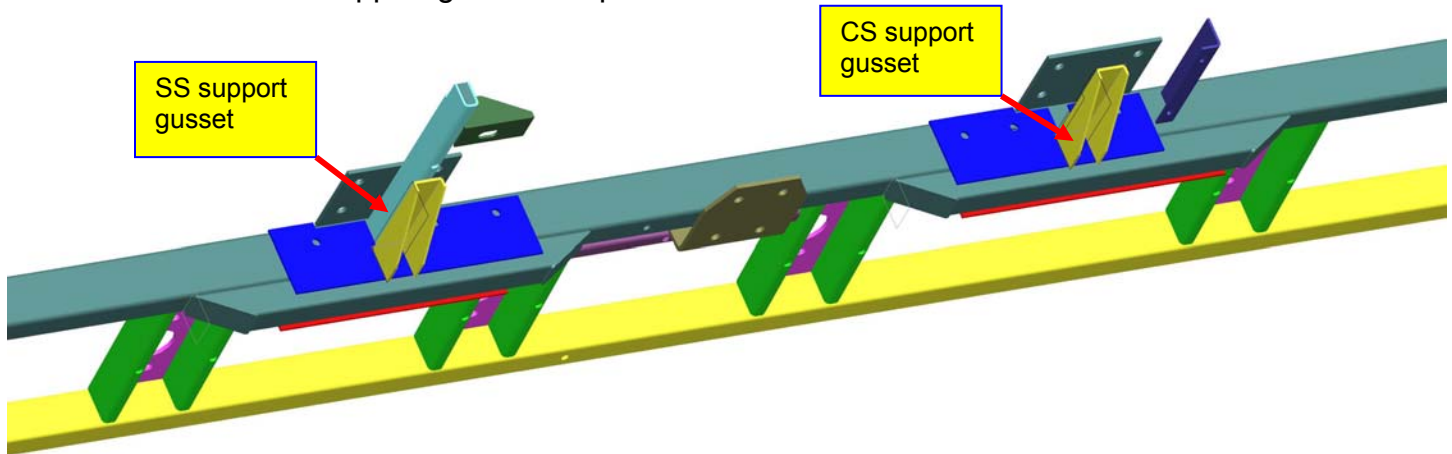

# New Jersey Transit: Fan Support Bracket Repair



- Weld SS support gusset solid at interface with cross-member and 1-3 stitch with the longitudinal beam.
- Plug weld the SS support gusset to the bottom of the brace. On buses equipped with CAT and 2007 Cummins engines weld the CS support gusset same as the SS bracket.

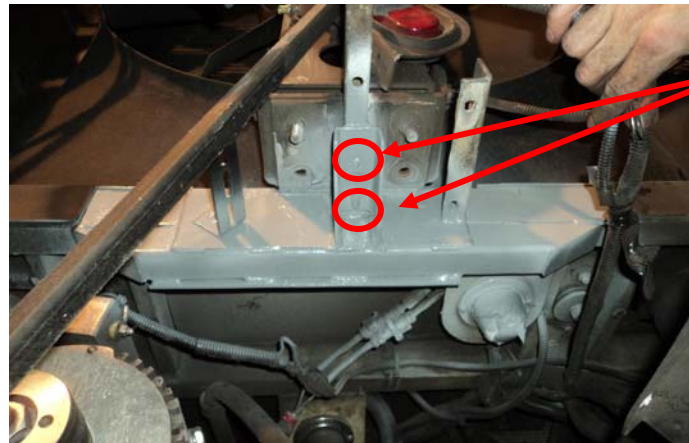

Plug welds

**On buses equipped with the 2010 Cummins engine the CS support brace is removable in order to replace fan drive belt. Do not weld the support bracket to the brace! The slots on the support bracket are for the 1/4-20 bolts!**

- Weld CS support gusset solid at interface with cross-member. On buses equipped with CAT and 2007 Cummins engines weld the CS support gusset same as the SS bracket.
- Welds per **WPS 35/40LFW-R02**.

1-3  TYP

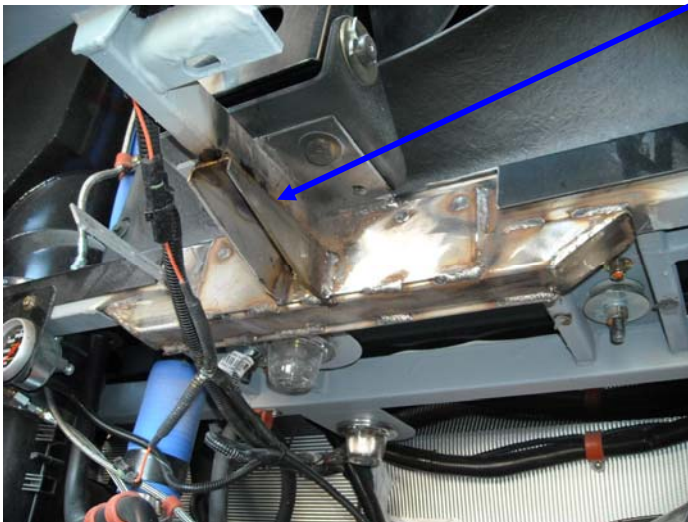

## New Jersey Transit: Fan Support Bracket Repair



24. On buses equipped with CAT engines, weld the original inner bracket of the control box to the CS tie plate (P/N **10C-1301-224**).

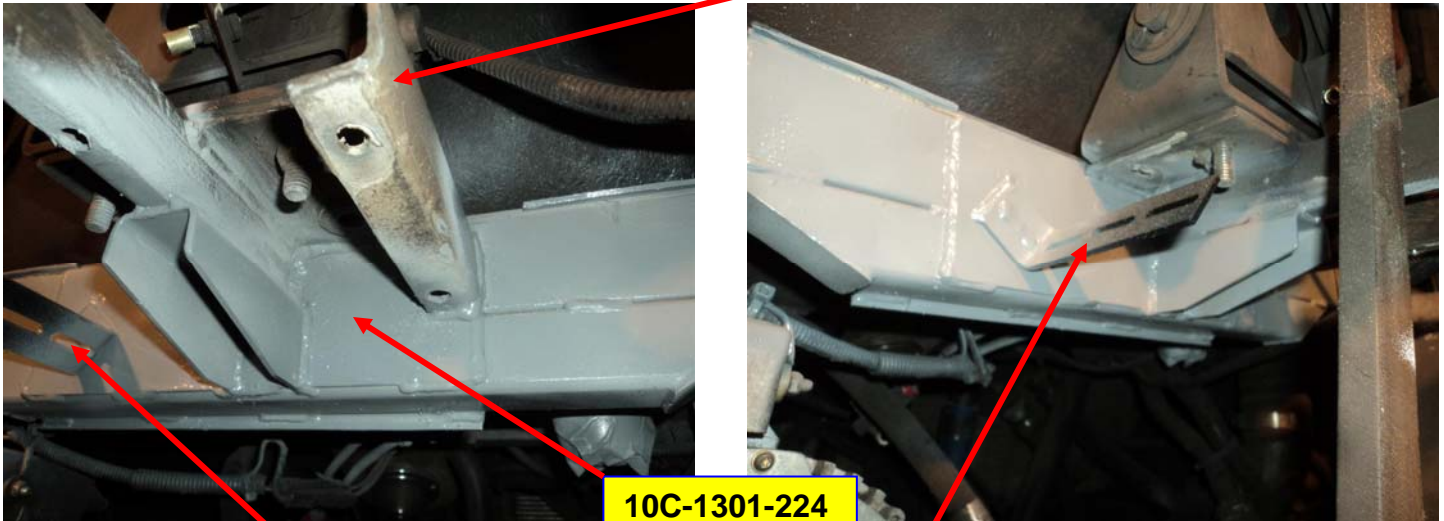

25. Weld the slotted bar (PN **5015886**) to the CS tie plate as picture shows above.

26. Clean welded area with wire brush.

27. Degrease surfaces.

28. Apply primer onto the new parts.

29. Apply gray color paint to the primed surfaces.

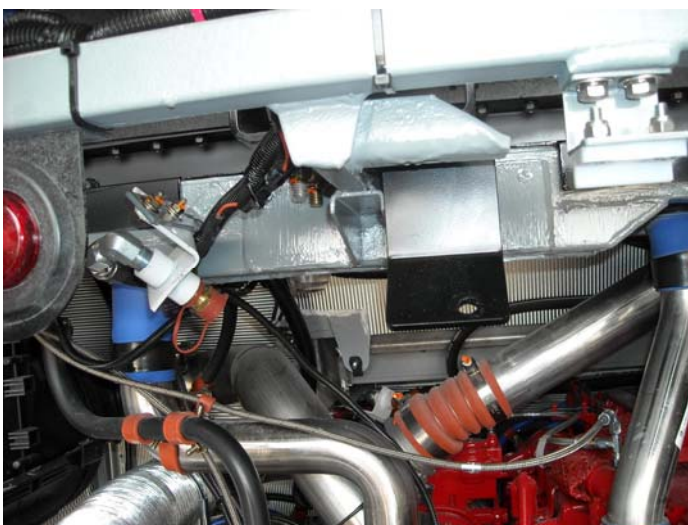

## New Jersey Transit: Fan Support Bracket Repair



30. Reinstall removed components.
31. Reconnect the ECU of engine, transmission and ABS. Reconnect the destination signs. Reconnect and turn on the PA system. Reconnect the 2 way weather pack connector at the fire suppression bottle. Reconnect the clever device behind the front SS seat. Reconnect all IO control modules.
32. Reconnect battery cables. Ensure that the battery compartment is well ventilated: use a fan to remove any trace of hydrogen gases from the compartment. **Wear safety glasses and gloves!**
33. Check for completeness of work.
34. Remove all tools from work area.
35. Turn the main battery disconnect switch(es) on.
36. Ensure that the control panel of the fire suppression system is on and the fire alarm light is off.
37. Start the bus and check the driver's display for warning lights.
38. Check the rear marker lights to make sure they are all working.
39. Record bus #, mileage, date of completion and the name of technician who performed the work.

