

REFERENCE:	Nova Bus Manuals
SECTION:	09 Engine
RS N°:	MQR 7621-336
EFFECTIVE IN PROD.:	L692-34 (2012DE)

APPLICATION DEADLINE: 2013DE11
-----------------------------------

SUBJECT:	Engine cooling system
JUSTIFICATION:	Certain clamps could loosen and cause a coolant leak.

LEVEL	DESCRIPTION	DIRECT CHARGES		TIME
		LABOUR	MATERIAL	
1	Verify the positioning of the breeze clamps, and if necessary, replenish the liquid coolant system.	Nova Bus	Nova Bus	1h
2	–	–	–	–

**MATERIAL**

QTY	PART N°	REV.	DESCRIPTION	REPLACES PART N°
<b>LEVEL 1</b>				
–	–	–	–	–
<b>LEVEL 2</b>				
–	–	–	–	–

**DISPOSAL OF PARTS**

REMOVED PARTS ARE:	DISCARDED	RETAINED	–
	–	–	

**REVISION HISTORY**

REV.	DATE	CHANGE DESCRIPTION	WRITTEN BY
NR	2012NO06	Initial release	Danielle Lacroix

CLIENT	ORDER	ROAD NUMBER		VIN (2NVY/4RKY...)		QTY
		FROM	TO	FROM	TO	
New York City Transit - New York	L608	8000	8014	L82U6B4000047	L82U0B4000061	15
New York City Transit - New York	L620	8015	8074	L82U2B4000062	L82U7B4000123	60
New York City Transit - New York	L621	8075	8089	L82U9B4000124	L82U9B4000138	15
New York City Transit - New York	L643	5895	5895	S92U1B4000143	S92U1B4000143	1
New York City Transit - New York	L670	5771	5894	S92U9B4000147	S92U8C4500060	124
New York City Transit - New York	L670	5770	5770	S92UXC4500061	S92UXC4500061	1
New York City Transit - New York	L681	5896	5986	S92U2C4500023	S92U9C4500164	91
New York City Transit - New York	L681	5253	5283	S92U0C4500165	S92U9C4500195	31
New York City Transit - New York	L692	5284	5317	S92U3C4500158	S92U9C4500228	34

**WARNING**

Follow your internal safety procedures.

**PROCEDURE**

- 1.1. Ensure the proper positioning of the clamp on the hoses according to the specifications in Figure 1. The clamp must be over the hose, perpendicular to the hose/piping assembly, at a minimum of 1/16 inch from the end of the hose, and before the fitting/piping bead. See Figure 2 for the installation steps.

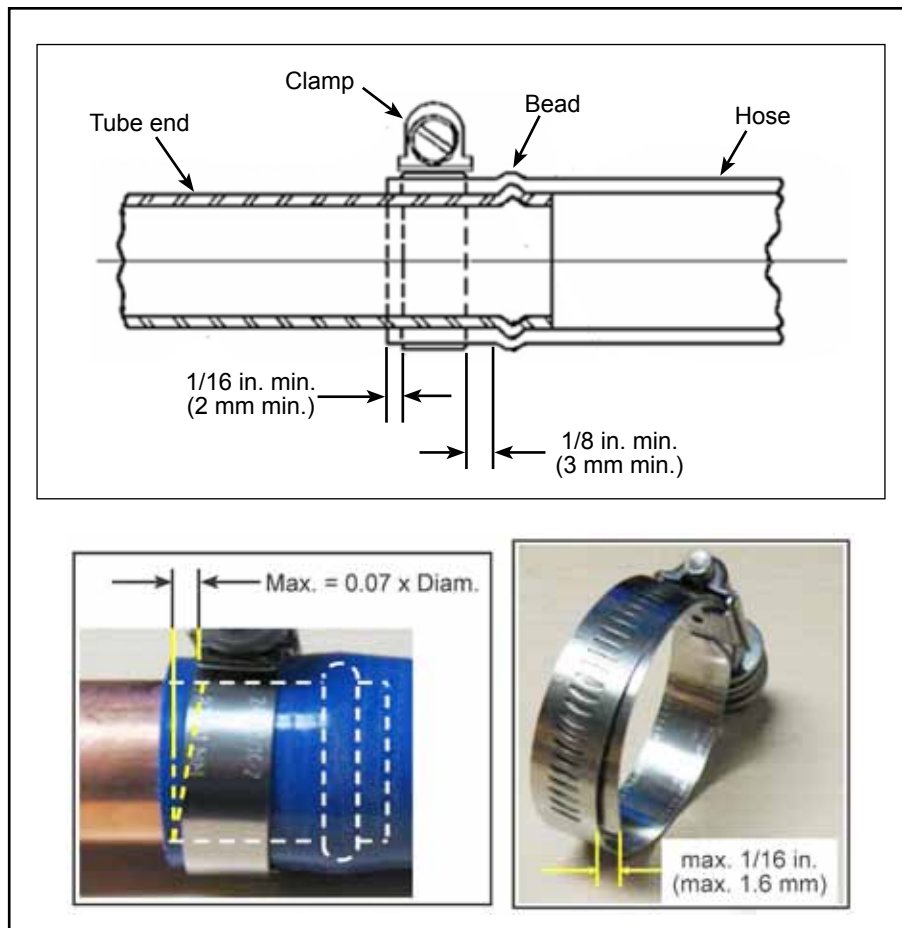
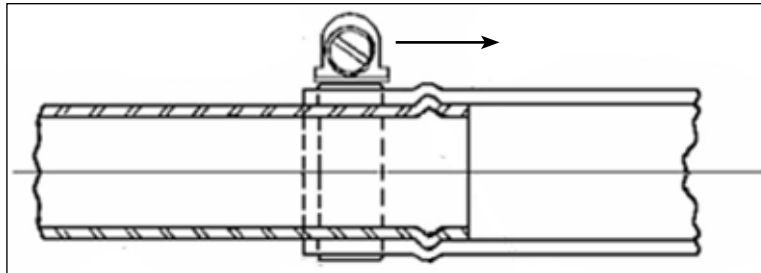
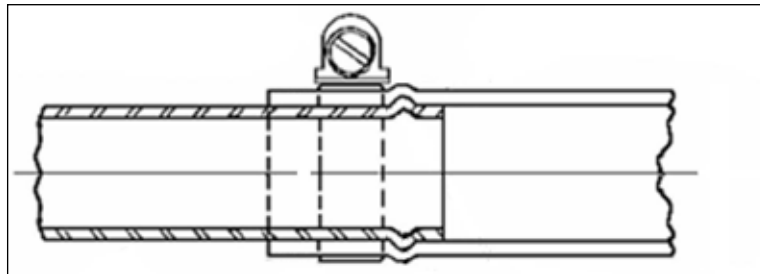

Figure 1 - Specifications for the Installation of Breeze Clamps



Step 1: Place the clamp on the hose and tighten until you feel a slight resistance while moving the clamp along the hose...



Step 2: ...but not able to go further than the beginning of the bead.

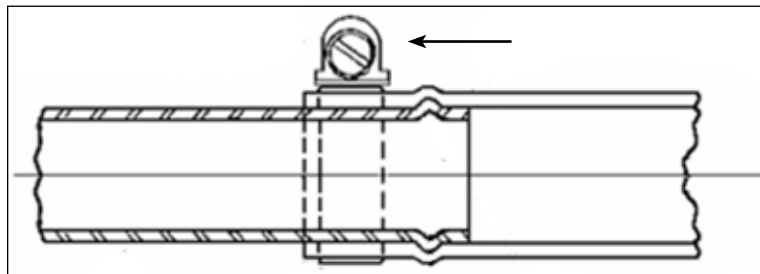

Step 3: Move the clamp back of at least 1/8 in. (3 mm). Make sure there is at least 1/16 in. (2 mm) from the edge of the hose to the edge of the clamp.

Specifications:

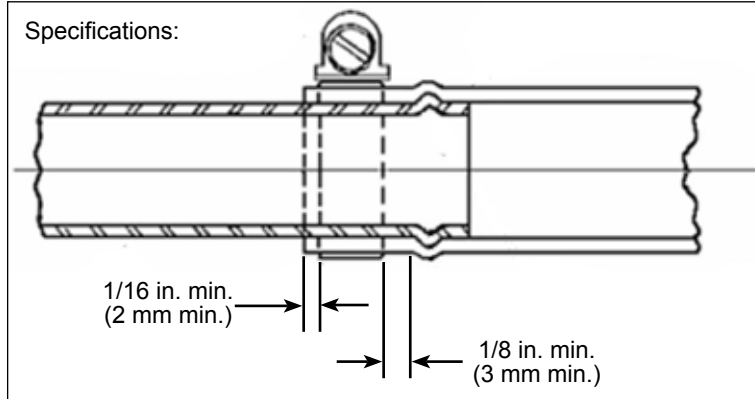

Figure 2 - Steps for the Installation of the Clamps

- 1.2. All the clamps in the bus should be checked, but a particular attention should be given to the clamps shown in Figures 3 to 9. Reposition a clamp only if there is a leak. If the overlap of the hose on a pipe is insufficient, move the pipe towards the hose to allow a sufficient overlap.
- 1.3. If a clamp has been repositioned, tighten the clamps securely to the torque indicated in the Figures. Be careful not to over tighten and damage the hoses.
- 1.4. Check the level in the coolant system. If necessary, refill the system with a coolant pre-mix 50/50 (ethylene glycol/water) as per AVT-0018 in Annex 1. ❖

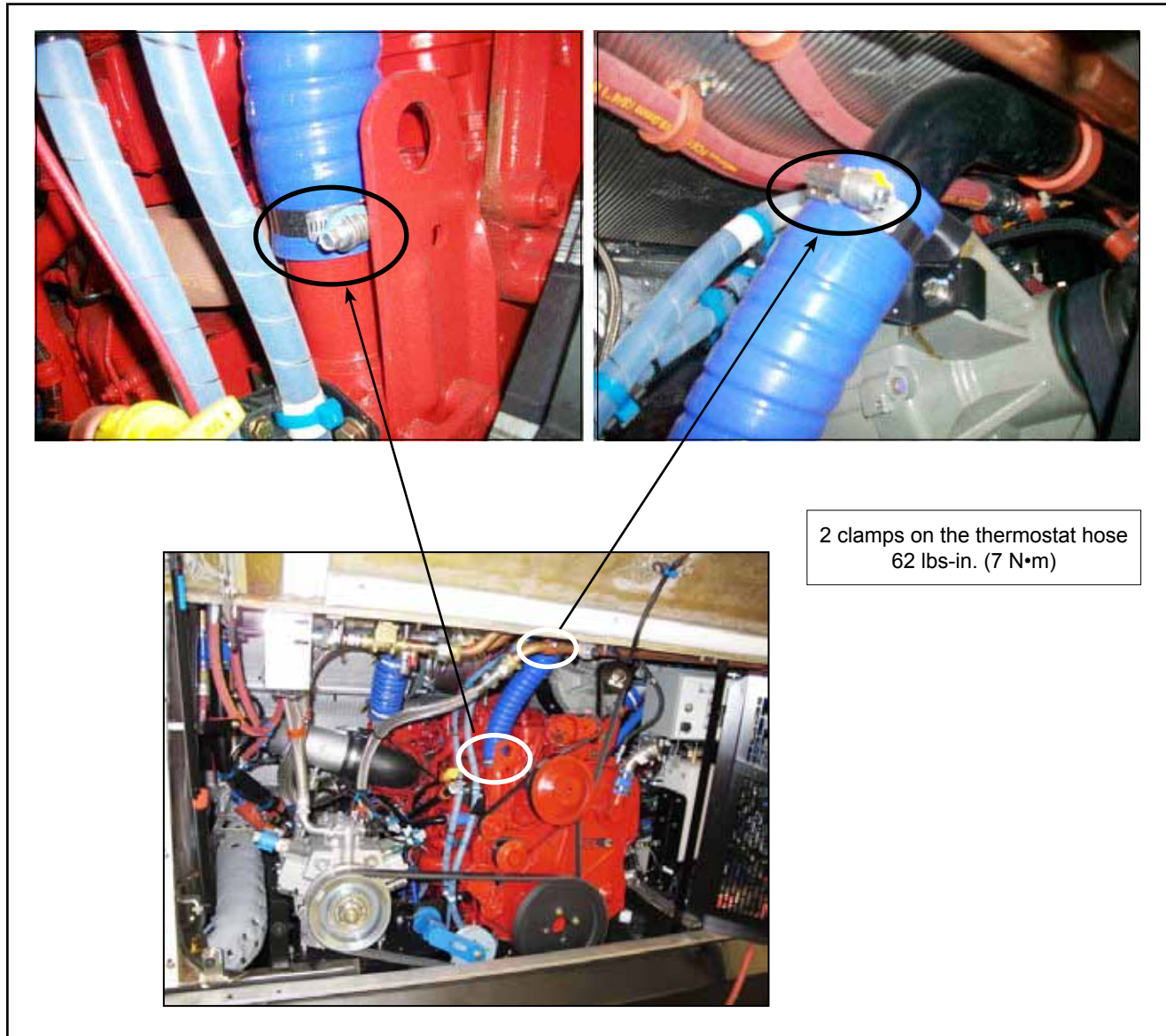

Figure 3 - View From the Rear Engine Access Door

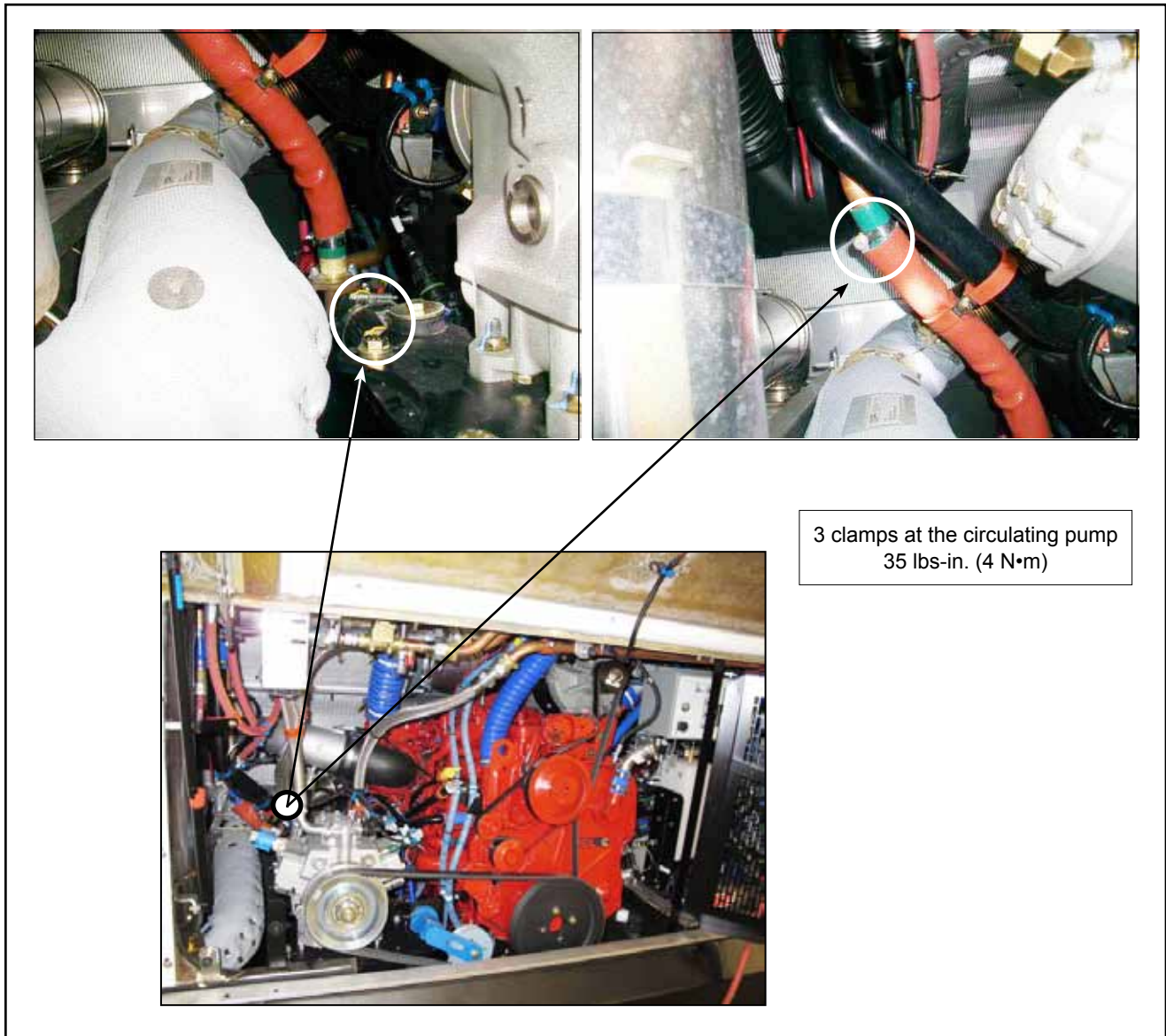
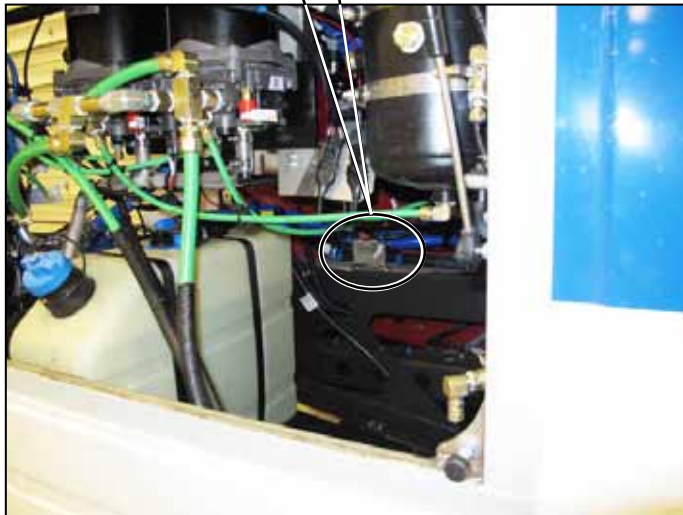

Figure 4 - Zone view From the Rear Engine Access Door



2 clamps in DEF area  
22.5 lbs-in. (2.5 N•m)



*Figure 5 - View From the Curb Side Engine Access Door*

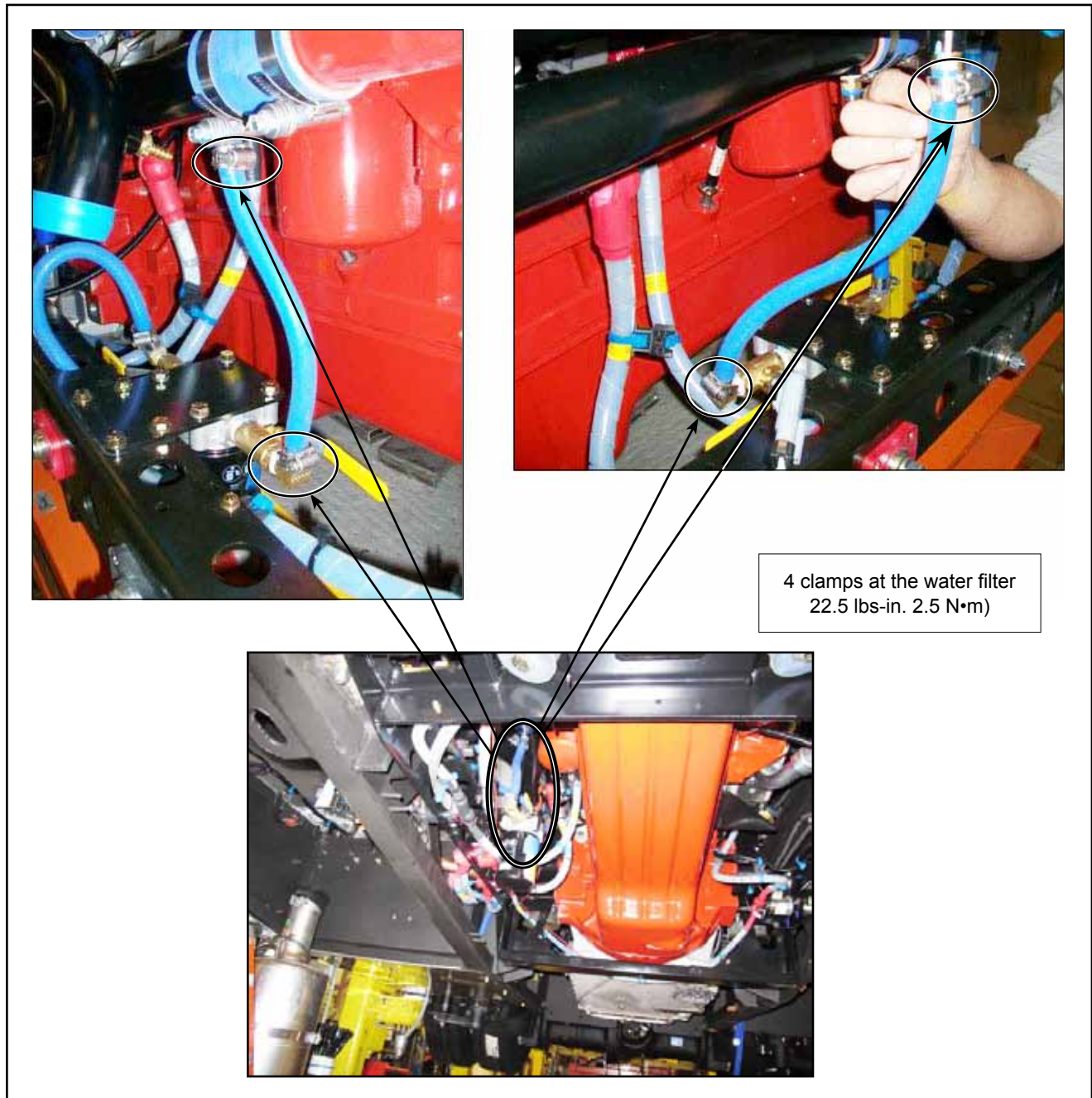

Figure 6 - Zone View From Under the Vehicle

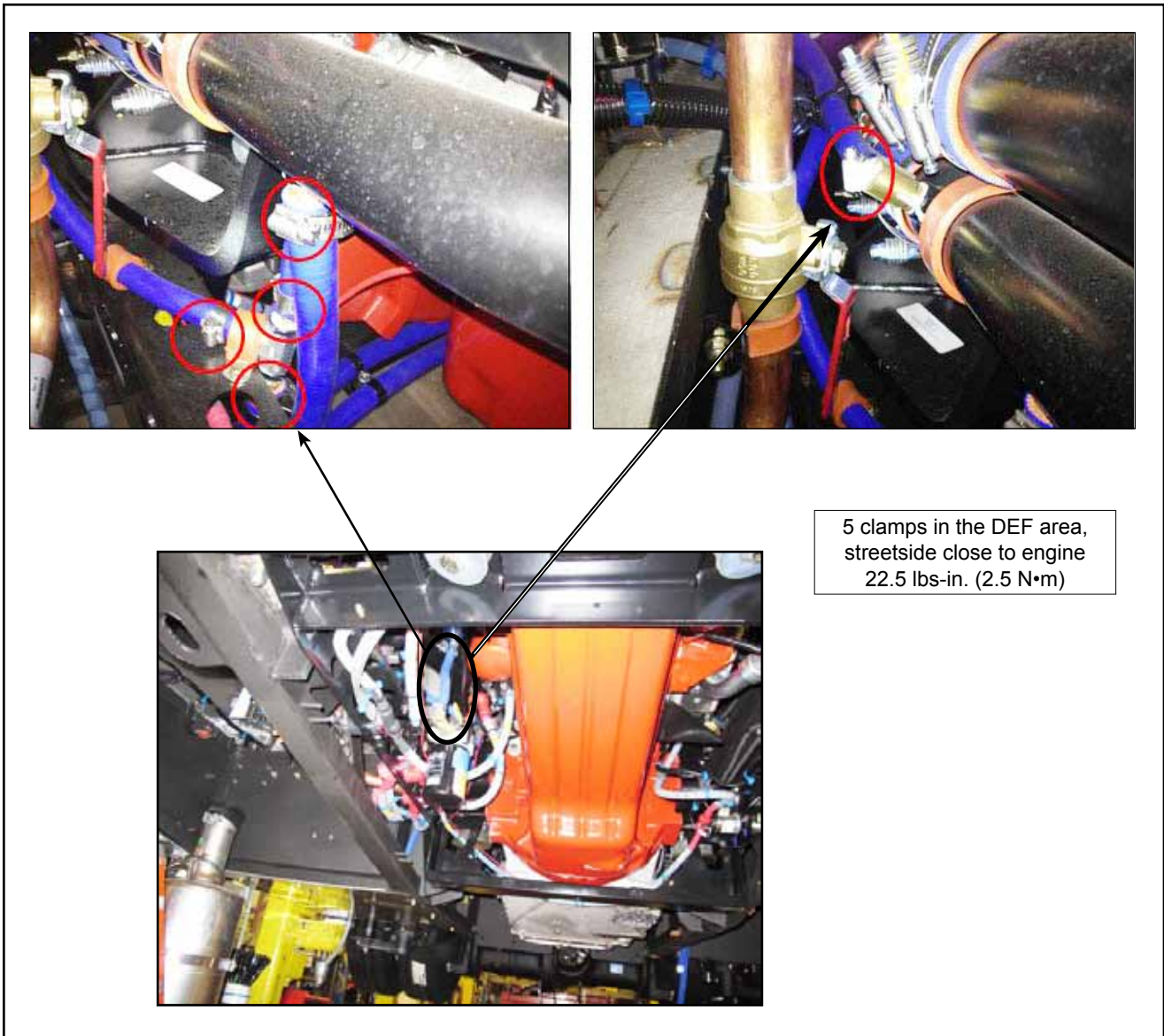

Figure 7 - Zone View From Under the Vehicle

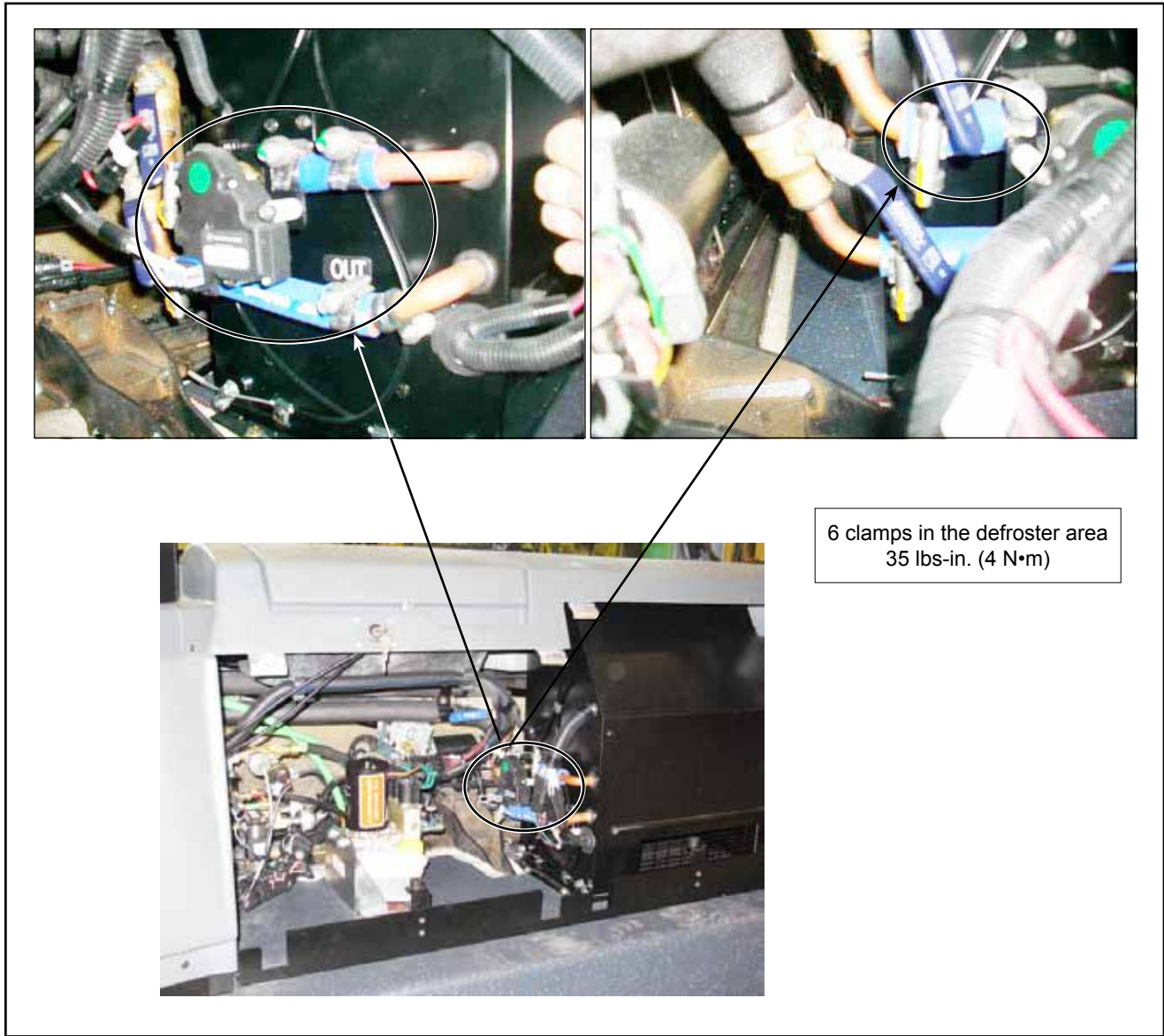
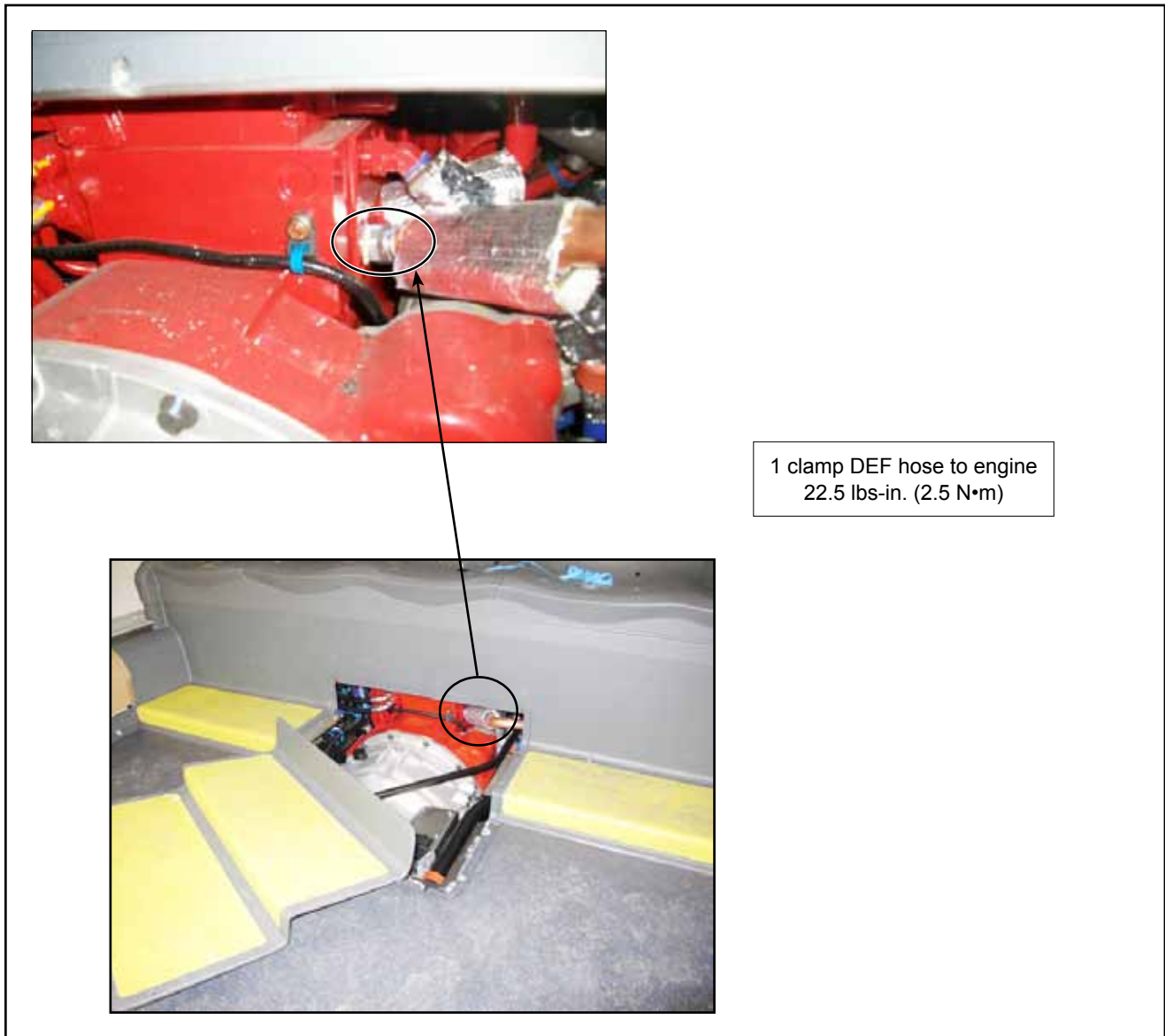

Figure 8 - Zone Under the Dash



*Figure 9 - Access Door in Front of the 5-Place Seat*

**ANNEX 1**

NOVA BUS TECHNICAL NOTICE  
***ENGINE COOLING SYSTEM FILLING, AND COLD FLUID CHECK PROCEDURE***  
*AVT-0018*



**TECHNICAL NOTICE**

<b>RE:</b>	<b>ENGINE COOLING SYSTEM FILLING and COLD FLUID CHECK PROCEDURE</b>	<b># AVT-0018</b>
		<b>PAGE: 1 / 8</b>
		<b>Model: NOVA LFS</b>

**1.0 OBJECTIVE**

To develop a procedure for filling the vehicle cooling system.

**2.0 FILLING**

**Note1** : Cooling liquid quantity show on BOM must be used as reference only. To properly fill up the cooling system this procedure must be followed.

- 2.1** Make sure the heating system drain valves are closed:
  - floor radiator valves
  - main drain valve located at the front of the bus, in the center, next to the defroster.
- 2.2** Make sure that the defroster supply/return valves are open when present under the dashboard.
- 2.3** Also check that the recirculating pump valve is open.
- 2.4** Connect the coolant filling hose to the quick connect fitting located at the rear of the vehicle and put a bucket or any recipient under the drain pipe to collect any overflowing.
- 2.5** Ensure that the Master switch, located on the driver side console, is set to Off.



**Figure 1**

<b>MANUFACTURING ENGINEERING DEPT.</b>	<b>REV</b>	<b>DATE</b>
<b>PREPARED BY: Denis ST-JEAN</b>	<b>NR</b>	<b>1999-02-02</b>
<b>REVISED BY: Sylvain Bradet</b>	<b>Q</b>	<b>2012-10-12</b>
<b>VERIFIED BY: Dave O'Connor</b>	<b>Q</b>	<b>2012-10-12</b>

**TECHNICAL NOTICE**

<b>RE:</b>	<b>ENGINE COOLING SYSTEM FILLING and COLD FLUID CHECK PROCEDURE</b>	<b># AVT-0018</b>
		<b>PAGE: 2 / 8</b>
		<b>Model: NOVA LFS</b>

- 2.6** Set the Maintenance switch, located on the driver top (above the driver's seat on the left side), to On (figure 2).



**Figure 2**

- 2.7** Set the dashboard heat switch to Heat to allow the coolant to fill (figure 3).



**Figure 3**

- 2.8** Activate HVAC switch located on the front top panel (Figure 4)

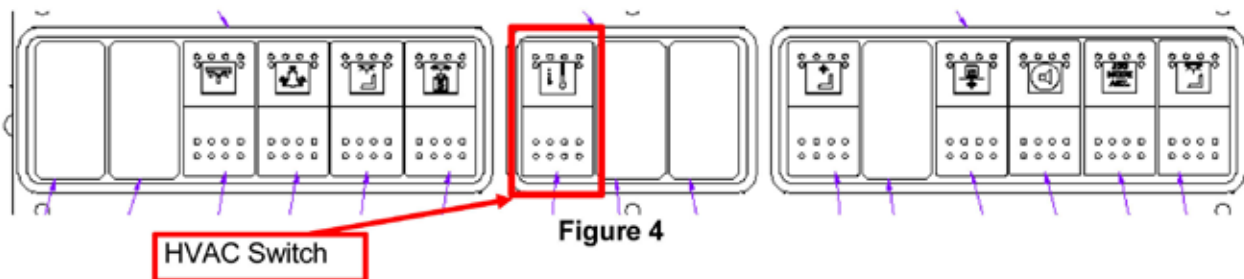

**Figure 4**

<b>MANUFACTURING ENGINEERING DEPT.</b>	<b>REV</b>	<b>DATE</b>
<b>PREPARED BY: Denis ST-JEAN</b>	<b>NR</b>	<b>1999-02-02</b>
<b>REVISED BY: Sylvain Bradet</b>	<b>Q</b>	<b>2012-10-12</b>
<b>VERIFIED BY: Dave O'Connor</b>	<b>Q</b>	<b>2012-10-12</b>

**TECHNICAL NOTICE**

<b>RE:</b>	<b>ENGINE COOLING SYSTEM FILLING and COLD FLUID CHECK PROCEDURE</b>	<b># AVT-0018</b>
		<b>PAGE: 3 / 8</b>
		<b>Model: NOVA LFS</b>

- 2.9 If vehicle has a CARRIER air conditioning unit, the roof unit valve must be activated with a test cable.
  - 2.9.1 Open inside panel to access the roof unit control panel.
  - 2.9.2 Remove the relay identify HEAT (Figure 5).
  - 2.9.3 Where was located the relay HEAT, connect one end of the test cable on the terminal 87 (Figure 5).
  - 2.9.4 Connect the other end of the test cable on the 24V power (Figure 5).

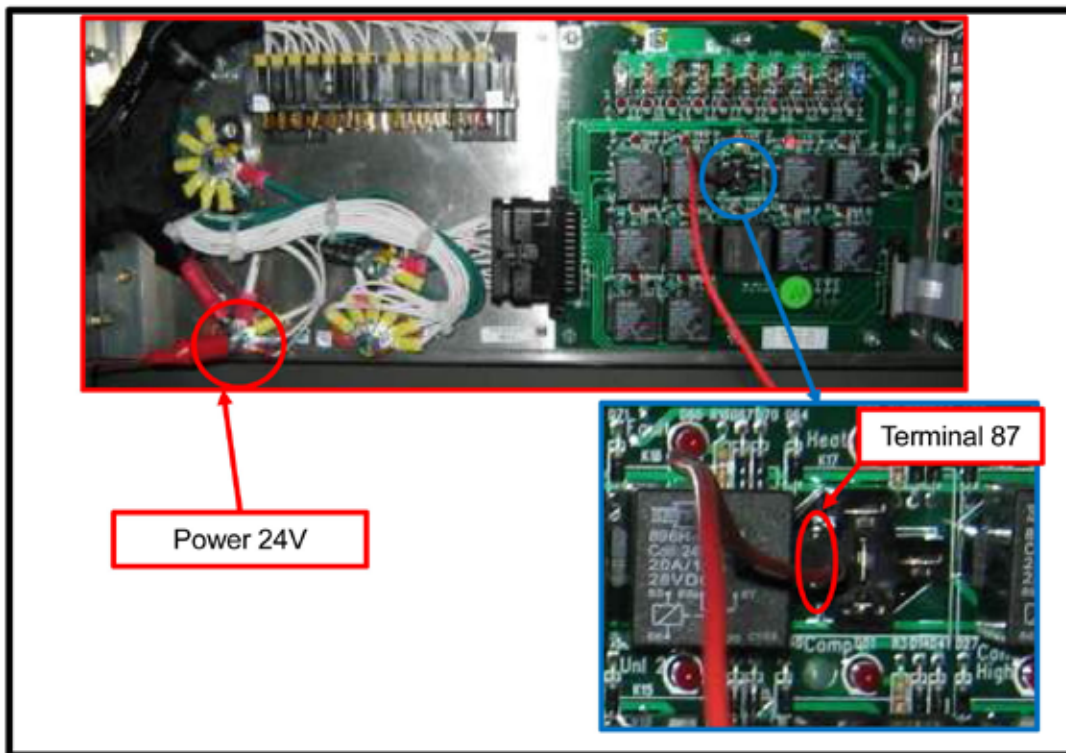

**Figure 5**

<b>MANUFACTURING ENGINEERING DEPT.</b>	<b>REV</b>	<b>DATE</b>
<b>PREPARED BY: Denis ST-JEAN</b>	<b>NR</b>	<b>1999-02-02</b>
<b>REVISED BY: Sylvain Bradet</b>	<b>Q</b>	<b>2012-10-12</b>
<b>VERIFIED BY: Dave O'Connor</b>	<b>Q</b>	<b>2012-10-12</b>

**TECHNICAL NOTICE**

<b>RE:</b>	<b>ENGINE COOLING SYSTEM FILLING and COLD FLUID CHECK PROCEDURE</b>	<b># AVT-0018</b>
		<b>PAGE: 4 / 8</b>
		<b>Model: NOVA LFS</b>

**2.10** Set the Engine control switch, located on the rear engine control box in the engine compartment, in center position (figure6).



**Figure 6**

**2.11** Press the Engine start switch, located on the rear engine control box in the engine compartment, down for 5 seconds and release. (figure 7)



**Figure 7**

**2.12** Press the Engine start switch down once more for 1 second and release. The center brake light should flash slowly. (figure 7)

<b>MANUFACTURING ENGINEERING DEPT.</b>	<b>REV</b>	<b>DATE</b>
<b>PREPARED BY: Denis ST-JEAN</b>	<b>NR</b>	<b>1999-02-02</b>
<b>REVISED BY: Sylvain Bradet</b>	<b>Q</b>	<b>2012-10-12</b>
<b>VERIFIED BY: Dave O'Connor</b>	<b>Q</b>	<b>2012-10-12</b>



TECHNICAL NOTICE

RE:	ENGINE COOLING SYSTEM FILLING and COLD FLUID CHECK PROCEDURE	# AVT-0018
		PAGE: 5 / 8
		Model: NOVA LFS

- 2.13 Then press the Engine start switch down once more for 1 second and release. The center brake light should flash more quickly and the circulating pump should activate, allowing the fluid to circulate. (figure 7)
- 2.14 Start to fill the system and press and hold the button under the quick connect fitting to purge the air from the surge tank. It is **VERY IMPORTANT** that the button stay press throughout the filling to avoid a buildup of pressure inside the tank.
- 2.15 If the vehicle is equipped with an electric cooling package (ECP), fill the system until the low level light on the motor control box (ACTIA) turns off and then add 4 more liters. If equipped with a hydraulic radiator, fill the system until overflow is coming out from the drain pipe.
- 2.16 Start the engine to purge the air from the system and validate the cooling system level. To start the engine, set the Engine control switch to Rear and press on Engine start. (figure 8). Let the engine run at fast idle for ten minutes.



Figure 8

MANUFACTURING ENGINEERING DEPT.	REV	DATE
PREPARED BY: Denis ST-JEAN	NR	1999-02-02
REVISED BY: Sylvain Bradet	Q	2012-10-12
VERIFIED BY: Dave O'Connor	Q	2012-10-12

TECHNICAL NOTICE

RE:	ENGINE COOLING SYSTEM FILLING and COLD FLUID CHECK PROCEDURE	# AVT-0018
		PAGE: 6 / 8
		Model: NOVA LFS

2.17 Validate the engine cooling system level using ACTIA. The ACTIA message should stop flashing once the level is ok. (figure 9)



Figure 9

2.18 Disconnect the test cable installed previously.

3.0 **SYSTEM DE-AERATION for electric fan cooling package only**  
(For hydraulic fan cooling package go to the next section.)

3.1 With pressure cap removed, start the engine.  
**IMPORTANT:** release pressure before removing the cap.

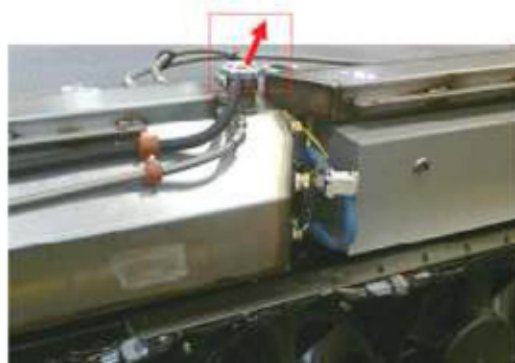

Figure 10

MANUFACTURING ENGINEERING DEPT.	REV	DATE
PREPARED BY: Denis ST-JEAN	NR	1999-02-02
REVISED BY: Sylvain Bradet	Q	2012-10-12
VERIFIED BY: Dave O'Connor	Q	2012-10-12



**TECHNICAL NOTICE**

<b>RE:</b>	<b>ENGINE COOLING SYSTEM FILLING and COLD FLUID CHECK PROCEDURE</b>	<b># AVT-0018</b>
		<b>PAGE: 7 / 8</b>
		<b>Model: NOVA LFS</b>

- 3.2 Let engine run at idle for 3 minutes.
- 3.3 Validate the engine cooling system level using ACTIA. If needed add coolant following procedure shown in previous section.



**Figure 11**

- 3.4 Run the engine at 2200 RPM until the coolant temperature reaches 190° F (approximately 10 min, depending on the ambient temperature) and then let it run for another 15 min. Make sure the coolant temperature doesn't exceed 200°.

**Note 2 :** It's also possible to shut off coolant fans in the breaker box to accelerate the heating of the coolant.

- 3.5 Decrease gradually the engine speed to idle speed to prevent coolant splashing.
- 3.6 Validate the engine cooling system level using ACTIA. If needed add coolant.
- 3.7 Turn off the engine.
- 3.8 Reinstall the pressure cap.
- 3.9 Turn main switch 'off'
- 3.10 Engine control to 'normal'
- 3.11 Set the Maintenance switch to "Off".

MANUFACTURING ENGINEERING DEPT.	REV	DATE
PREPARED BY: Denis ST-JEAN	NR	1999-02-02
REVISED BY: Sylvain Bradet	Q	2012-10-12
VERIFIED BY: Dave O'Connor	Q	2012-10-12

F.4.09.3 REV. 11/2002

NOVA BUS

## TECHNICAL NOTICE

RE:	ENGINE COOLING SYSTEM FILLING and COLD FLUID CHECK PROCEDURE	# AVT-0018
		PAGE: 8 / 8
		Model: NOVA LFS

## 4.0 ADJUSTMENTS

**NOTE:** Coolant verification results are only valid when the vehicle coolant is considered "cold". This has been defined as being between 5°C and 40°C.

- 4.1 The coolant level must be checked once again after the vehicle coolant has cooled enough to be considered cold
- 4.2 If any coolant level adjustments are required, they must be made when the vehicle coolant is considered cold
- 4.3 If the vehicle is equipped with a coolant recovery tank (coolant tank overflow), the tank must be emptied once the final coolant level has been established.

## 5.0 REVISIONS

- Q Section 2.8 added  
Figure 4 added

MANUFACTURING ENGINEERING DEPT.	REV	DATE
PREPARED BY: Denis ST-JEAN	NR	1999-02-02
REVISED BY: Sylvain Bradet	Q	2012-10-12
VERIFIED BY: Dave O'Connor	Q	2012-10-12

F.4.09.3 REV. 11/2002