

WC36 - Replacing Retaining Clip for Temperature Sensor (Workshop Campaign)

Vehicle Type: **Cayenne S (92A)/Cayenne Turbo (92A)**

Model Year: **2012**

Concerns: **Retaining clip for coolant temperature sensor in the coolant hose**

Information: This is to inform you of a voluntary Workshop Campaign on the above-mentioned vehicles.

There is a possibility that retaining clips of the wrong size were used to secure the coolant temperature sensor on the affected vehicles due to a supplier error.

As a result, the retaining clip can become detached from the temperature sensor.

Action Required: Replace the retaining clip for the coolant temperature sensor prior to vehicle delivery to customers.

Affected Vehicles: The VIN(s) can be checked by using PIWIS Vehicle Information link to verify if the campaign affects the vehicle. This Campaign is scope specific to the VIN! Failure to verify in PIWIS may result in an improper repair.

Note: DUE TO THE LOW NUMBER OF AFFECTED VEHICLES **THERE WILL BE NO AUTOMATIC ALLOCATION OF PARTS** FOR THIS CAMPAIGN. PLEASE FILE A PTEC FOR RELEASE OF REQUIRED PART(S).

Parts Info: 000.043.207.93 ⇒ Retaining clip 1 ea.

Tools: Pliers

Work Procedure: See Attachment "A".

Claim Submission: See Attachment "B".

Attachment "A": **Work Procedure**

1 Open front lid.

WARNING**Hot fluid**

- **Danger of scalding**
- ⇒ **Let the fluid cool down.**
- ⇒ **Wear personal protective gear.**

- 2 Carefully open the cap on the coolant reservoir briefly to relieve any residual pressure in the cooling system.

**Information**

Have new retaining clip ready before removing the old retaining clip from the temperature sensor.

**Information**

As soon as you have removed the old retaining clip from the temperature sensor, **press against** the temperature sensor to prevent it from slipping out of the coolant hose connecting piece and to prevent coolant from leaking out.

- 3 Replace retaining clip for coolant temperature sensor.
- 3.1 Pull off retaining clip ⇒ *Figure 1 -1-* for the temperature sensor ⇒ *Figure 1 -2-* using a pliers.
Hold the temperature sensor firmly while doing this to prevent it from slipping out of the coolant hose connecting piece.
- 3.2 **Fit new** retaining clip ⇒ *Figure 1 -1-*, Part No. **000.043.207.93**, on the temperature sensor ⇒ *Figure 1 -2-*.
- 4 Close front lid.
- 5 Enter the workshop campaign in the Warranty and Maintenance booklet.

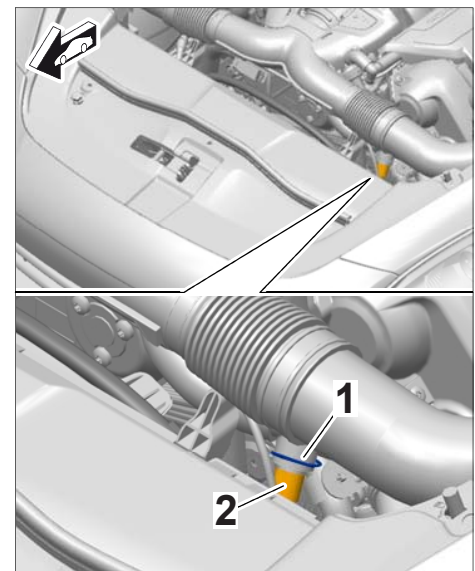

Figure 1

Attachment "B": **Claim Submission** - Workshop Campaign WC36
Warranty claims should be submitted via WWS/PQIS.

Open campaigns may be checked by using either the PIWIS Vehicle Information system or through PQIS Job Creation.

Labor will be inserted automatically when the technician is selected in WWS. If necessary, the required part numbers will need to be manually entered into WWS by the dealer administrator.

Scope 1: **Replacing retaining clip for temperature sensor**

Working time:
 Replacing retaining clip for temperature sensor Labor time: **31 TU**

Parts required:
 000.043.207.93 Retaining clip 1 ea.

⇒ **Damage code WC36 066 000 2**

Important Notice: Porsche Cars N.A Technical Bulletins are intended for use by professional technicians, not a "Do-it-yourselfer." They are written to inform these technicians of conditions that may occur on some vehicles, or to provide information that could assist in the proper service of a vehicle. Special tools may be required to perform certain operations identified in these bulletins. Use of tools and procedures other than those recommended in these bulletins may be detrimental to the safe operation of your vehicle. Properly trained technicians have the equipment, tools, safety instructions and know-how to do a job properly and safely. If a condition is described, do not assume that the bulletin applies to your vehicle, or that your vehicle will have that condition. See your Porsche Dealer for information on whether your vehicle may benefit from the information. Part numbers listed in these bulletins are for reference only. Always check with your authorized Porsche dealer to verify correct part numbers.

© Porsche Cars North America, Inc.

Dealership	Service Manager	Shop Foreman	Service Technician				
Distribution	Asst. Manager	Warranty Admin.	Service Technician				
Routing							

Dr. Ing. h.c. F. Porsche AG is the owner of numerous trademarks, both registered and unregistered, including without limitation the Porsche Crest®, Porsche®, Boxster®, Carrera®, Cayenne®, Cayman™, Panamera®, Tiptronic®, VarioCam®, PCM®, 911®, 4S®, FOUR, UNCOMPROMISED.® and the model numbers and distinctive shapes of Porsche's automobiles such as, the federally registered 911 and Boxster automobiles. The third party trademarks contained herein are the properties of their respective owners. Some vehicles may be shown with non-U.S. equipment. Porsche recommends seat belt usage and observance of traffic laws at all times.

Printed in the USA