

**WC19 - Checking and Reworking Wire Harness for Exterior Mirrors (Workshop Campaign)**

Vehicle Type: **Panamera/Panamera 4/  
Panamera S/Panamera 4S/Panamera S Hybrid  
Panamera Turbo/Panamera Turbo S**

Model Year: **As of 2011 up to 2012**

Equipment: Electrically retractable exterior mirrors (I-no. 258)  
Electrically retractable exterior mirrors with memory (I-no. 259)  
Electrically retractable exterior mirrors with automatic dimming (I-no. 260)  
Electrically retractable exterior mirrors with automatic dimming and memory (I-no. 261)

Concerns: **Wire harness for exterior mirrors**

Information: This is to inform you of a voluntary Workshop Campaign on the above-mentioned vehicles. There is the possibility that the wire harnesses in both exterior mirrors may not be routed correctly. As a result, the wire harnesses can become damaged when the exterior mirrors are folded in and the electric functions of the exterior mirrors can fail.

Action Required:

- Check routing of wire harnesses in both exterior mirrors and secure wire harnesses to the mirror base by installing an additional cable holder. ⇒ **Scope 1**
- Check routing of wire harnesses in both exterior mirrors, secure wire harnesses to the mirror base by installing an additional cable holder and replace wire harnesses that are already damaged. ⇒ **Scope 2 or 3**

Affected Vehicles: The VIN(s) can be checked by using PIWIS Vehicle Information link to verify if the campaign affects the vehicle. This Campaign is scope specific to the VIN! Failure to verify in PIWIS may result in an improper repair.

Note: NOT ALL VEHICLES WILL REQUIRE PARTS. VEHICLES MUST BE INSPECTED BEFORE PARTS CAN BE ORDERED. PLEASE FILE A PTEC FOR RELEASE OF REQUIRED PARTS AFTER A VEHICLE INSPECTION HAS BEEN COMPLETED. THERE WILL BE NO AUTOMATIC ALLOCATION OF PARTS.

Parts Info: **Scope 1:**  
Checking and reworking routing of wire harnesses in both exterior mirrors  
000.043.110.21 ⇒ Cable holder 2 ea.

**Scope 2 and 3:**

Checking and reworking routing of wire harnesses in both exterior mirrors and replacing wire harnesses that are already damaged.

000.043.110.21 ⇒ Cable holder 2 ea.

Different wire harnesses may also be needed for scope 2 and scope 3, depending on vehicle equipment.

- **Replacing one** damaged wire harness ⇒ use **Scope 2** for warranty processing.
- **Replacing two** damaged wire harnesses ⇒ use **Scope 3** for warranty processing.

Exterior mirror equipment		Part No.
Vehicles <b>with</b> Lane Change Assist (I-no. 457)		
I-no. 258	Electrically retractable exterior mirrors	970.612.666.50 ⇒ Wiring harness
I-no. 259	Electrically retractable exterior mirrors + memory	970.612.667.50 ⇒ Wiring harness
I-no. 260	Electrically retractable exterior mirrors + auto. dimming	970.612.668.50 ⇒ Wiring harness
I-no. 261	Electrically retractable exterior mirrors + auto. dimming + memory	970.612.669.50 ⇒ Wiring harness
Vehicles <b>without</b> Lane Change Assist		
I-no. 258	Electrically retractable exterior mirrors	970.612.666.00 ⇒ Wiring harness
I-no. 259	Electrically retractable exterior mirrors + memory	970.612.667.00 ⇒ Wiring harness
I-no. 260	Electrically retractable exterior mirrors + auto. dimming	970.612.668.00 ⇒ Wiring harness
I-no. 261	Electrically retractable exterior mirrors + auto. dimming + memory	970.612.669.00 ⇒ Wiring harness

Tools: Torx screw tool set Nr.49-1

Work Procedure: See Attachment "A".

Claim Submission: See Attachment "B".

Attachment "A": **Work Procedure**

**Checking and reworking routing of wire harnesses in both exterior mirrors**



**Information**

The procedure described here must be carried out **on both exterior mirrors**.

The figures show the work to be carried out on the **left** side of the vehicle in direction of travel. The work on the right side of the vehicle must be carried out in the same way.

- 1 Remove exterior mirror housing ⇒ *Workshop Manual '667919 Removing and installing housing for rear-view mirror - section on "Removing"*.
- 2 **Check routing of wire harness for exterior mirrors and check for signs of chafing.**



**Information**

**Figure 1** shows the **correct** routing of the wire harness at the exterior mirror.

**Figure 2** shows the **incorrect** routing of the wire harness.

- 2.1 **If** the wire harness for exterior mirrors ⇒ *Figure 1 -item 1-* as shown in ⇒ *Figure 1* is **in front of** the locking disc ⇒ *Figure 1 -item 2-* on the mirror base ⇒ *Figure 1 -arrow-* ⇒ the wire harness is **routed correctly**. ⇒ **Continue** with **Step 4.2** and secure the wire harness by installing an additional cable holder.

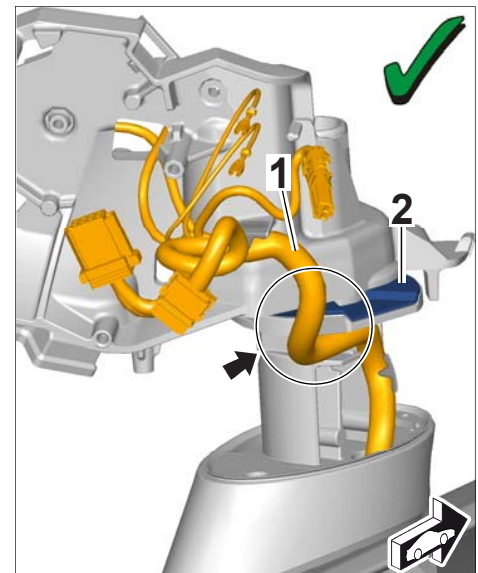

Figure 1

2.2 **If** the wire harness for exterior mirrors ⇒ *Figure 2 -item 1-* as shown in ⇒ *Figure 2* is **over** the locking disc ⇒ *Figure 2 -item 2-* on the mirror base ⇒ *Figure 2 -arrow-*⇒ the wire harness is **not routed correctly**. ⇒ **Continue** with **Step 2.2.1** and **check** the wire harness for signs of chafing.

2.2.1 **If** the protective sleeve (fabric tape) on the wire harness is **worn through**⇒ **continue** with **Step 3** and **replace** the wire harness.

2.2.2 **If** the protective sleeve (fabric tape) on the wire harness is **not worn through**⇒ **continue** with **Step 4** and **route the wire harness correctly** and secure it by fitting an additional cable holder.

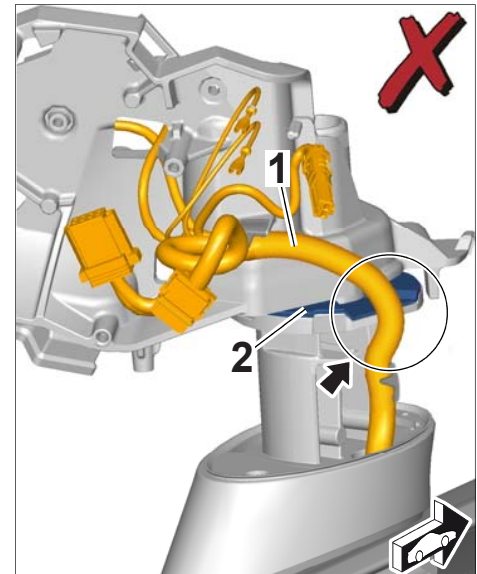

Figure 2



#### Information

If the protective sleeve (fabric tape) on the wire harness is **chafed** ⇒ **wrap insulating tape** around the chafed area and then route the wire harness correctly.

### 3 Replacing wire harness

3.1 Remove wire harness for exterior mirrors ⇒ *Workshop Manual '974319 Removing and installing wire harness for rear-view mirror - section on "Installing"*.

3.2 **Install new** wire harness for exterior mirrors ⇒ *Workshop Manual '974319 Removing and installing wire harness for rear-view mirror - section on "Installing"*.

### 4 Retrofit additional cable holder for securing the wire harness.

- 4.1 Route the wire harness ⇒ *Figure 3* -**item 1**- as shown in ⇒ *Figure 3* so that it is routed **in front of** the locking disc ⇒ *Figure 3* -**item 2**- on the mirror base.

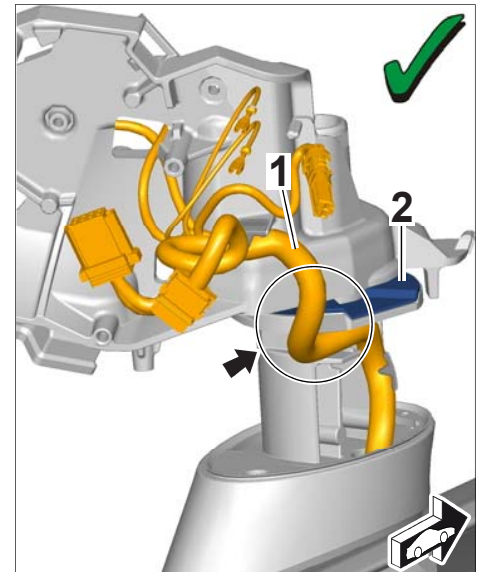

Figure 3

- 4.2 Install an additional cable holder ⇒ *Figure 4* -**item 2**- as shown in ⇒ *Figure 4* on the mirror base ⇒ *Figure 4* -**item 3**- and use it to secure the wire harness ⇒ *Figure 4* -**item 1**-.

- 5 Install exterior mirror housing ⇒ *Workshop Manual '667919 Removing and installing housing for rear-view mirror - section on "Installing"*.
- 6 Complete steps 1 to 5 on the other exterior mirror.
- 7 Enter the workshop campaign in the Warranty and Maintenance booklet.

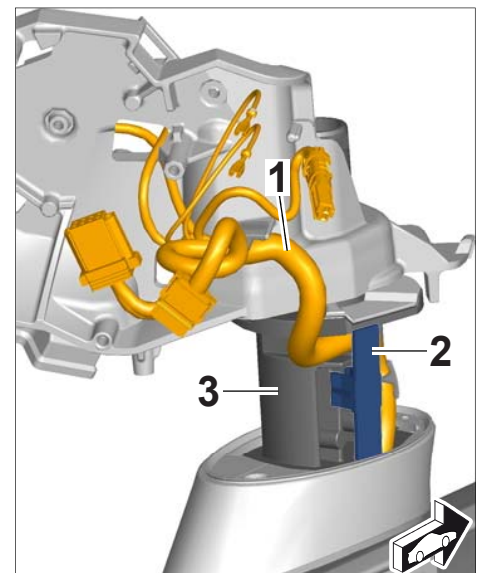

Figure 4

Attachment "B": **Claim Submission** - Workshop Campaign WC19

Warranty claims should be submitted via WWS/PQIS.

Note: Open campaigns can be checked by using the PIWIS Vehicle Information link.

Labor, parts, and sublet will be automatically inserted when Technician is selected in WWS/PQIS.

Scope 1: **Checking and reworking routing of wire harnesses in both exterior mirrors****Working time:**Checking and reworking routing of wire harnesses in both exterior mirrors Labor time: **62 TU**

## Includes:

- Removing and installing mirror glass
- Removing and installing mirror adjusting motor
- Removing and installing exterior mirror housing
- Retrofitting cable holder on wire harness

**Parts Required:**

000.043.110.21 Cable holder 2 ea.

⇒ **Damage code WC19 066 000 1**Scope 2: **Checking and reworking routing of wire harnesses in both exterior mirrors and replacing one wire harness****Working time:**Checking and reworking routing of wire harnesses in both exterior mirrors and replacing one wire harness Labor time: **96 TU**

## Includes:

- Removing and installing mirror glass
- Removing and installing mirror adjusting motor
- Removing and installing exterior mirror housing
- Removing and installing exterior mirrors
- Removing and installing wire harness for exterior mirrors
- Retrofitting cable holder on wire harness

**Parts Required:**

000.043.110.21 Cable holder 2 ea.

Also **one** of the following wiring harnesses, depending on vehicle equipment:Vehicles **with** Lane Change Assist (I-no. 457)

970.612.666.50 Wiring harness 1 ea.  
I-no. 258 - Vehicles with electrically retractable exterior mirrors

970.612.667.50 Wiring harness 1 ea.  
I-no. 259 - Vehicles with electrically retractable exterior mirrors + memory

970.612.668.50	Wiring harness I-no. 260 - Vehicles with electrically retractable exterior mirrors + auto. dimming	1 ea.
970.612.669.50	Wiring harness I-no. 261 - Vehicles with electrically retractable exterior mirrors + auto. dimming + memory	1 ea.
Vehicles <b>without</b> Lane Change Assist		
970.612.666.00	Wiring harness I-no. 258 - Vehicles with electrically retractable exterior mirrors	1 ea.
970.612.667.00	Wiring harness I-no. 259 - Vehicles with electrically retractable exterior mirrors + memory	1 ea.
970.612.668.00	Wiring harness I-no. 260 - Vehicles with electrically retractable exterior mirrors + auto. dimming	1 ea.
970.612.669.00	Wiring harness I-no. 261 - Vehicles with electrically retractable exterior mirrors + auto. dimming + memory	1 ea.
⇒ <b>Damage code WC19 066 000 2</b>		

Scope 3:

**Checking and reworking routing of wire harnesses in both exterior mirrors and replacing both wire harnesses**

<b>Working time:</b>	
Checking and reworking routing of wire harnesses in both exterior mirrors and replacing both wire harnesses	Labor time: <b>130 TU</b>
Includes:	
<ul style="list-style-type: none"> <li>Removing and installing mirror glass</li> <li>Removing and installing mirror adjusting motor</li> <li>Removing and installing exterior mirror housing</li> <li>Removing and installing exterior mirrors</li> <li>Removing and installing wire harness for exterior mirrors</li> <li>Retrofitting cable holder on wire harness</li> </ul>	
<b>Parts required:</b>	
000.043.110.21	Cable holder 2 ea.

Also **two** of the following wiring harnesses, depending on vehicle equipment:

Vehicles **with** Lane Change Assist (I-no. 457)

970.612.666.50	Wiring harness I-no. 258 - Vehicles with electrically retractable exterior mirrors	2 ea.
970.612.667.50	Wiring harness I-no. 259 - Vehicles with electrically retractable exterior mirrors + memory	2 ea.
970.612.668.50	Wiring harness I-no. 260 - Vehicles with electrically retractable exterior mirrors + auto. dimming	2 ea.
970.612.669.50	Wiring harness I-no. 261 - Vehicles with electrically retractable exterior mirrors + auto. dimming + memory	2 ea.

Vehicles **without** Lane Change Assist

970.612.666.00	Wiring harness I-no. 258 - Vehicles with electrically retractable exterior mirrors	2 ea.
970.612.667.00	Wiring harness I-no. 259 - Vehicles with electrically retractable exterior mirrors + memory	2 ea.
970.612.668.00	Wiring harness I-no. 260 - Vehicles with electrically retractable exterior mirrors + auto. dimming	2 ea.
970.612.669.00	Wiring harness I-no. 261 - Vehicles with electrically retractable exterior mirrors + auto. dimming + memory	2 ea.

⇒ **Damage code WC19 066 000 2**

- References:
- ⇒ *Workshop Manual '667819 Removing and installing mirror glass'*
  - ⇒ *Workshop Manual '667919 Removing and installing housing for rear-view mirror'*
  - ⇒ *Workshop Manual '668219 Removing and installing mirror adjusting motor'*
  - ⇒ *Workshop Manual '668919 Removing and installing rear-view mirror'*
  - ⇒ *Workshop Manual '706119 Removing and installing trim for front door panel'*



⇒ Workshop Manual '974319 Removing and installing wire harness for rear-view mirror'

**Important Notice:** Porsche Cars N.A Technical Bulletins are intended for use by professional technicians, not a "Do-it-yourselfer." They are written to inform these technicians of conditions that may occur on some vehicles, or to provide information that could assist in the proper service of a vehicle. Special tools may be required to perform certain operations identified in these bulletins. Use of tools and procedures other than those recommended in these bulletins may be detrimental to the safe operation of your vehicle. Properly trained technicians have the equipment, tools, safety instructions and know-how to do a job properly and safely. If a condition is described, do not assume that the bulletin applies to your vehicle, or that your vehicle will have that condition. See your Porsche Dealer for information on whether your vehicle may benefit from the information. Part numbers listed in these bulletins are for reference only. Always check with your authorized Porsche dealer to verify correct part numbers.

© Porsche Cars North America, Inc.

---

Dealership	Service Manager	_____	Shop Foreman	_____	Service Technician	_____	_____	_____	_____
Distribution	Asst. Manager	_____	Warranty Admin.	_____	Service Technician	_____	_____	_____	_____
Routing									

---

Dr. Ing. h.c. F. Porsche AG is the owner of numerous trademarks, both registered and unregistered, including without limitation the Porsche Crest®, Porsche®, Boxster®, Carrera®, Cayenne®, Cayman™, Panamera®, Tiptronic®, VarioCam®, PCM®, 911®, 4S®, FOUR, UNCOMPROMISED.® and the model numbers and distinctive shapes of Porsche's automobiles such as, the federally registered 911 and Boxster automobiles. The third party trademarks contained herein are the properties of their respective owners. Some vehicles may be shown with non-U.S. equipment. Porsche recommends seat belt usage and observance of traffic laws at all times.

Printed in the USA