



Service Bulletin

File in Section: -

Bulletin No.: PI0848

Date: October, 2012

PRELIMINARY INFORMATION

Subject: Front Side Door Window Upper Reveal Molding Fit/Appearance/Clearance

Models: 2010-2012 Buick LaCrosse
Built Prior to May 1, 2012

Condition/Concern

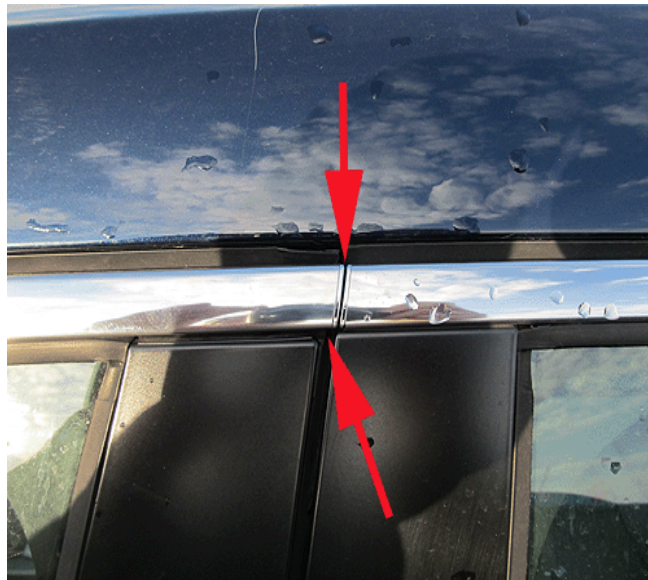

2964012

Some customers may comment that the gap between the front and rear door upper window reveal molding is too small or the front door reveal molding contacts the rear door reveal molding. This condition may be present on the left or right front door.

This condition may be caused by the metal section of the front side door reveal molding moving out of position within the molding assembly.

Recommendation/Instructions

Use the following steps to reposition and secure the front side door upper reveal molding metal strip to the surrounding rubber seal.

1. Place the front door window in the full down position.



2964013

2. Slide the molding metal strip forward in the vehicle to create a flush fit with the upper rear edge of the door frame.

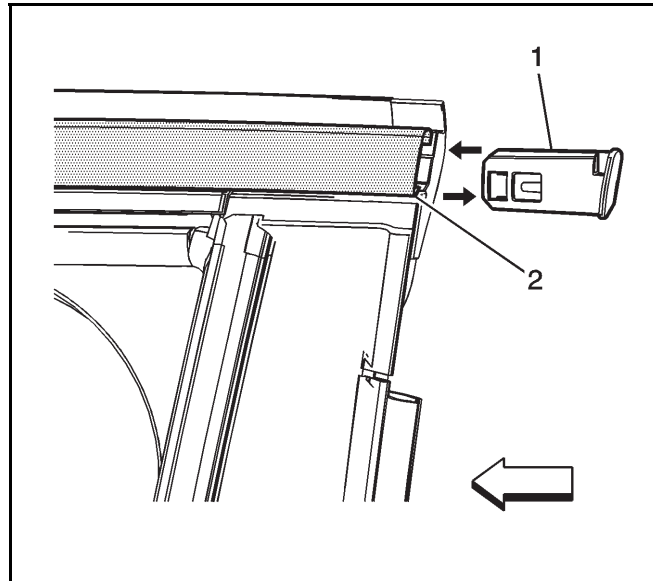

2369328

3. Remove the front side door upper reveal molding end cap (1), located at the top rear corner of the front door upper reveal molding (2).

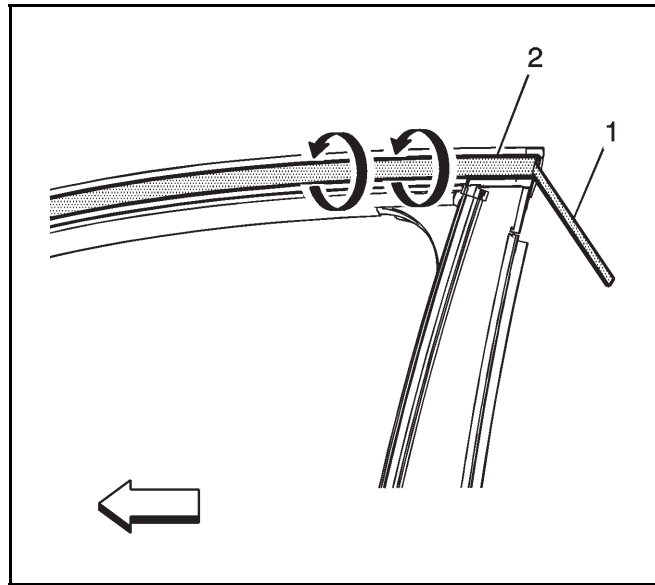

2369329

4. Insert a suitable plastic trim removal stick (1) under the rear corner of the reveal molding (2) and turn the plastic tool (1) clockwise while pulling upward. This will allow the reveal molding to release. Only loosen the last 50 mm (2.0 in) of the metal molding.

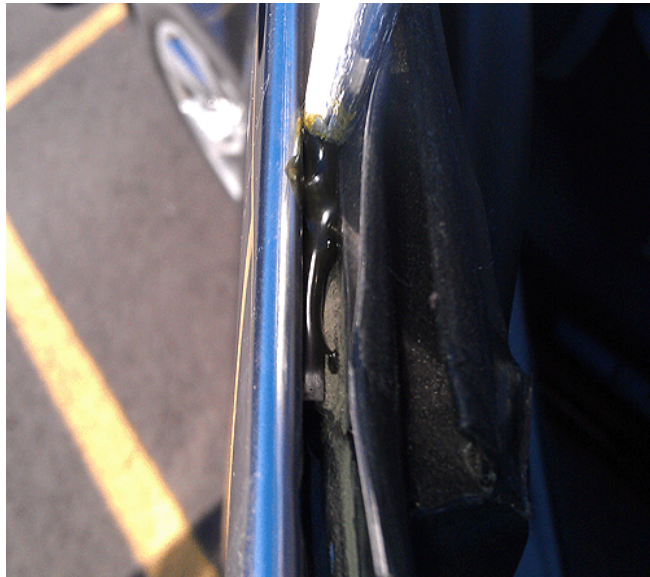

2964015

5. Apply GM Vehicle Care Weatherstrip Adhesive Gel-Black, P/N 12345097 (in Canada, P/N 10953479), to the weatherstrip where the reveal molding engages as shown.
6. Reinstall the end cap to the front door upper reveal molding.
7. Using the palm of your hand, push down and inward firmly to lock the metal reveal molding into the rubber molding.
8. Clean up any excess adhesive using a general purpose adhesive cleaner.

Parts Information

Part Number	Description
12345097 (in Canada, P/N 10953479)	GM Vehicle Care Weatherstrip Adhesive Gel-Black

Warranty Information

For vehicles repaired under warranty, use:

Labor Operation	Description	Labor Time
B6834*	Front Side Door Upper Reveal Molding – Align And Secure	0.3 hr
*This is a unique labor operation for bulletin use only. It will not be published in the Labor Time Guide.		