



**2013**

# **Touareg**

**Quick Reference  
Specification Book**



# 2013 Volkswagen Touareg Quick Reference Specification Book

## TABLE OF CONTENTS

<b>General Information .....</b>	<b>1</b>
Decimal and Metric Equivalents .....	1
Tightening Torque .....	2
Warnings and Cautions .....	4
<b>Vehicle Identification.....</b>	<b>9</b>
Vehicle Identification Number (VIN) Location .....	9
VIN Decoder .....	10
Vehicle Data Label Location .....	11
<b>Sales Codes .....</b>	<b>12</b>
Engine Codes .....	12
Transmission Codes .....	12
<b>Vehicle Lifting .....</b>	<b>13</b>
Hoist and Jack Mounting Points .....	13
Front .....	13
Rear .....	14

## ENGINES

<b>Engine Mechanical – 3.0L CNRB (TDI) .....</b>	<b>15</b>
General, Technical Data .....	15
Engine Number Location .....	15
Engine Data .....	16
Engine Assembly – 3.0L CNRB (TDI).....	17
Fastener Tightening Specifications.....	17
Crankshaft, Cylinder Block – 3.0L CNRB (TDI).....	18
Allocation of Crankshaft Bearing Shells for Cylinder Block ...	18
Allocation of Crankshaft Bearing Shells for Guide Frame .....	19
Fastener Tightening Specifications.....	20
Ribbed Belt Pulley Side Sealing Flange Tightening Specification.....	21
Guide Frame Tightening Specifications.....	24
Crankshaft Dimensions .....	25
Piston and Cylinder Dimensions.....	25
Piston Ring End Gaps .....	25
Piston Ring Clearance.....	25

Cylinder Head, Valvetrain – 3.0L CNRB (TDI).....	26
Fastener Tightening Specifications.....	26
Valve Dimensions .....	27
Compression Pressures .....	27
Left Cylinder Head Cover Tightening Specifications .....	28
Right Cylinder Head Cover Tightening Specifications .....	29
Cylinder Head Tightening Specifications .....	30
Upper Timing Chain Cover Tightening Specifications .....	31
Lower Timing Chain Cover Tightening Specifications .....	32
Cylinder Bank 1 (Right) Bearing Cap Tightening Specifications .....	35
Cylinder Bank 2 (Left) Bearing Cap Tightening Specifications .....	36
Lubrication – 3.0L CNRB (TDI).....	37
Fastener Tightening Specifications.....	37
Upper Oil Pan Tightening Specifications .....	38
Oil Pan Tightening Specifications .....	39
Cooling System – 3.0L CNRB (TDI) .....	41
Fastener Tightening Specifications.....	41
Fuel Supply – 3.0L CNRB (TDI) .....	41
Fastener Tightening Specifications.....	41
Turbocharger, G-Charger – 3.0L CNRB (TDI) .....	42
Fastener Tightening Specifications.....	42
Turbocharger Tightening Specifications .....	42
Exhaust System – 3.0L CNRB (TDI) .....	43
Fastener Tightening Specifications.....	43
Exhaust Manifold Tightening Specifications .....	44
EGR Pipe at the Intake Manifold Tightening Specifications ..	45
EGR Pipe at the Turbocharger Tightening Specifications .....	46
Diesel Fuel Injection – 3.0L CNRB (TDI).....	47
Fastener Tightening Specifications.....	47
Fuel Pressure Regulator Valve Tightening Specifications .....	47
Fuel Pressure Sensor Tightening Specifications .....	48
Intake Manifold Tightening Specifications .....	48
Ignition/Glow Plug System – 3.0L CNRB (TDI) .....	48
Fastener Tightening Specifications.....	48
<b>ENGINE MECHANICAL – 3.0L CGFA.....</b>	<b>49</b>
General, Technical Data .....	49
Engine Number Location .....	49
Engine Data .....	50

Engine Assembly – 3.0L CGFA.....	51
Fastener Tightening Specifications.....	51
Electro-Drive Drive Motor to Engine Tightening Specifications .....	52
Transmission to Electro-Drive Drive Motor Tightening Specifications .....	53
Crankshaft, Cylinder Block – 3.0L CGFA.....	54
Allocation of Crankshaft Bearing Shells for Cylinder Block ...	54
Allocation of Crankshaft Bearing Shells for Guide Frame .....	55
Fastener Tightening Specifications.....	56
Ribbed Belt Sealing Flange Tightening Specification .....	57
Guide Frame Tightening Specifications .....	58
Crankshaft Dimensions .....	59
Piston Ring End Gaps .....	59
Piston Ring Clearance.....	59
Piston and Cylinder Dimensions.....	59
Cylinder Head, Valvetrain – 3.0L CGFA.....	60
Fastener Tightening Specifications.....	60
Compression Checking Specifications .....	61
Valve Dimensions .....	61
Left Timing Chain Cover Tightening Specifications .....	62
Right Timing Chain Cover Tightening Specifications.....	63
Lower Timing Chain Cover Tightening Specifications .....	64
Cylinder Head Tightening Specifications .....	65
Camshaft Guide Frame Tightening Specifications .....	66
Left Cylinder Head Cover Tightening Specification .....	67
Right Cylinder Head Cover Tightening Specification.....	67
Engine Lubrication – 3.0L CGFA .....	68
Fastener Tightening Specifications.....	68
Upper Oil Pan Tightening Specifications .....	69
Oil Pan Tightening Specifications .....	70
Cooling System – 3.0L CGFA.....	70
Fastener Tightening Specifications.....	70
Fuel Supply – 3.0L CGFA.....	71
Fastener Tightening Specifications.....	71
Turbocharger, G-Charger - 3.0L CGFA.....	71
Fastener Tightening Specifications.....	71
Exhaust System, Emission Controls – 3.0L CGFA.....	72
Fastener Tightening Specifications.....	72
Left Exhaust Manifold Tightening Specifications .....	73
Right Exhaust Manifold Tightening Specifications.....	74

Multiport Fuel Injection – 3.0L CGFA.....	75
Technical Data .....	75
Fastener Tightening Specifications.....	75
Lower Intake Manifold Tightening Specification .....	76
Ignition/Glow Plug System – 3.0L CGFA .....	76
Technical Data .....	76
Fastener Tightening Specifications.....	76
<b>Engine Mechanical – 3.6L CGRA.....</b>	<b>77</b>
General, Technical Data .....	77
Engine Number Location .....	77
Engine Data .....	78
Engine Assembly – 3.6L CGRA.....	78
Fastener Tightening Specifications.....	78
Crankshaft, Cylinder Block – 3.6L CGRA.....	79
Allocation of Crankshaft Bearing Shells for Cylinder Block ...	79
Cylinder Block Identification .....	79
Crankshaft Identification .....	80
Fastener Tightening Specifications.....	82
Sealing Flange Tightening Specifications .....	83
Accessory Bracket Tightening Specifications .....	84
Crankshaft Dimensions .....	85
Piston Ring End Gaps .....	85
Piston Ring Clearance.....	85
Piston and Cylinder Dimensions.....	85
Cylinder Head, Valvetrain – 3.6L CGRA.....	86
Fastener Tightening Specifications.....	86
Compression Checking Specifications .....	86
Valve Dimensions .....	87
Dimensions for Intake Valves .....	87
Dimensions for Exhaust Valves .....	87
Cylinder Head Tightening Specifications .....	88
Camshaft Bearing Cap Tightening Specifications .....	89
Cylinder Head Cover Tightening Specification .....	90
Engine Lubrication – 3.6L CGRA.....	90
Fastener Tightening Specifications.....	90
Cooling System – 3.6L CGRA .....	91
Fastener Tightening Specifications.....	91
Fuel Supply – 3.6L CGRA.....	91
Fastener Tightening Specifications.....	91
Exhaust System, Emission Controls – 3.6L CGRA.....	92
Fastener Tightening Specifications.....	92

Multipoint Fuel Injection – 3.6L CGRA .....	92
Technical Data .....	92
Fastener Tightening Specifications.....	93
Upper Intake Manifold to Lower Intake Manifold Tightening Specification .....	94
Ignition – 3.6L CGRA.....	94
Technical Data .....	94
Fastener Tightening Specifications.....	94

## TRANSMISSION

<b>Automatic Transmission – 0C8 .....</b>	<b>95</b>
General, Technical Data .....	95
Transmission Identification .....	95
Code Letters and Transmission Allocations Vehicles with a Hybrid Engine.....	96
Vehicles with a Gas Engine .....	96
Vehicles with a Diesel Engine.....	96
Torque Converter .....	96
Fastener Tightening Specifications.....	96
Controls, Housing – 0C8 .....	97
Fastener Tightening Specifications.....	97
Securing Transmission to a 3.0L Hybrid Engine.....	98
Securing Transmission to a 3.0L TDI Engine .....	99
Securing Transmission to a 3.6L Engine .....	100
Gears, Hydraulic Controls – 0C8.....	101
Fastener Tightening Specifications.....	101
Valve Body Tightening Specifications.....	101
<b>Transfer Case And Final Drive .....</b>	<b>102</b>
General, Technical Data .....	102
Transfer Case Identification Location .....	102
Transfer Case Identification.....	103
Transfer Case Code Letter, Allocation and Capacities .....	104
Controls, Housing .....	104
Fastener Tightening Specifications.....	104
Front Final Drive – 0BM, 0C1 .....	105
Front Final Drive Identification Location .....	105
Front Final Drive Identification .....	105
Front Final Drive Code Letters, Allocation, Ratios and Capacities .....	106

Rear Final Drive – 0BN, 0BP .....	106
Rear Final Drive Identification Location .....	106
Rear Final Drive Identification .....	107
Rear Final Drive Code Letters, Allocation, Ratios and Capacities .....	108
Fastener Tightening Specifications.....	108

## **CHASSIS**

### **Suspension, Wheels, Steering ..... 109**

Front Suspension .....	109
Fastener Tightening Specifications.....	109
Rear Suspension .....	110
Fastener Tightening Specifications.....	110
Self-Leveling Suspension .....	111
Fastener Tightening Specifications.....	111
Wheels, Tires .....	112
Fastener Tightening Specifications.....	112
Wheel Alignment Data .....	112
Wheel Alignment Specified Values .....	112
Steering .....	113
Fastener Tightening Specifications.....	113

### **Brake System..... 115**

General Information .....	115
Vehicle Data Label.....	115
Front Brakes .....	116
Rear Brakes.....	116
Brake Master Cylinder and Brake Booster .....	116
Front Brakes, Brembo 17 Inch.....	117
Front Brakes, Brembo 18 Inch.....	118
Rear Disc Brakes.....	119
Drum Parking Brake .....	120
Anti-lock Brake System (ABS).....	121
Fastener Tightening Specifications.....	121
Mechanical Components .....	121
Fastener Tightening Specifications.....	121
Hydraulic Components .....	122
Fastener Tightening Specifications.....	122



<b>Body</b> .....	<b>123</b>
Air Gap Body Dimensions .....	123
Body, Front .....	123
Body, Center .....	124
Body, Rear .....	125
Body Exterior .....	126
Lock Carrier, Plenum Chamber Tightening Specifications ..	126
Front Fender, Noise Insulation and Underbody Trim Tightening Specifications .....	126
Front Hood Tightening Specifications .....	126
Rear Lid and Fuel Filler Door Tightening Specifications.....	126
Front and Rear Door Tightening Specifications .....	127
Sunroof Tightening Specifications .....	127
Front and Rear Bumper Tightening Specifications .....	127
Mirror and Roof Rail Tightening Specifications.....	128
Body Interior .....	128
Storage Compartment Covers and Trim Tightening Specifications .....	128
Passenger Protection Tightening Specifications .....	128
Interior Trim Tightening Specifications .....	129
Seat Frames Tightening Specifications .....	129
<b>Heating and Air Conditioning</b> .....	<b>130</b>
General, Technical Data .....	130
Refrigerant Oil Distribution .....	130
Refrigerant R134a Vapor Pressure Table .....	130
Heating, Ventilation.....	131
Fastener Tightening Specification .....	131
Air Conditioning .....	131
Fastener Tightening Specifications.....	131
<b>Electrical System</b> .....	<b>132</b>
Electrical Equipment.....	132
Battery, Starter, Generator, Cruise Control Tightening Specifications .....	132
Windshield Wiper/Washer Tightening Specifications.....	133
Exterior Lights, Switches Tightening Specifications .....	133
Interior Lights, Switches Tightening Specifications.....	133
Wiring Tightening Specifications.....	133

<b>DTC Chart.....</b>	<b>134</b>
Engine Code - CNRB .....	134
Fuel and Air Mixture, Additional Emissions Regulations.....	134
Ignition System .....	144
Additional Exhaust Regulation.....	145
Speed and Idle Control.....	147
Control Module and Output Signals.....	147
Fuel and Air Ratios Control Module.....	152
Additional Emissions Regulations .....	155
<b>DTC Chart.....</b>	<b>158</b>
Engine Code - CGFA.....	158
Fuel and Air Mixture, Additional Emissions Regulations.....	158
Ignition System .....	169
Additional Exhaust Regulation.....	171
Speed and Idle Control.....	173
Control Module and Output Signals.....	173
Fuel and Air Ratios Control Module.....	176
Ignition System .....	181
Additional Emissions Regulations .....	181
Fuel and Air Mixture, Additional Emissions Regulations.....	184
<b>DTC Chart.....</b>	<b>185</b>
Engine Code - CGRA .....	185
Fuel and Air Mixture, Additional Emissions Regulations.....	185
Ignition System .....	193
Additional Exhaust Regulation.....	196
Speed and Idle Control.....	196
Control Module and Output Signals.....	197
Fuel and Air Ratios Control Module.....	200
Ignition System .....	204
Additional Emissions Regulations .....	205

# GENERAL INFORMATION

## *Decimal and Metric Equivalents*

### Distance/Length

To calculate: mm x 0.03937 = in.

mm	in.	mm	in.	mm	in.	mm	in.
0.002	0.00008	0.01	0.0004	0.1	0.004	1	0.04
0.004	0.00016	0.02	0.0008	0.2	0.008	2	0.08
0.006	0.00024	0.03	0.0012	0.3	0.012	3	0.12
0.008	0.00031	0.04	0.0016	0.4	0.016	4	0.16
0.010	0.00039	0.05	0.0020	0.5	0.020	5	0.20
0.020	0.00079	0.06	0.0024	0.6	0.024	6	0.24
0.030	0.00118	0.07	0.0028	0.7	0.028	7	0.28
0.040	0.00157	0.08	0.0031	0.8	0.031	8	0.31
0.050	0.00197	0.09	0.0035	0.9	0.035	9	0.35
0.060	0.00236	0.10	0.0039	1.0	0.039	10	0.39
0.070	0.00276	0.20	0.0079	2.0	0.079	20	0.79
0.080	0.00315	0.30	0.0118	3.0	0.118	30	1.18
0.090	0.00354	0.40	0.0157	4.0	0.157	40	1.57
0.100	0.00394	0.50	0.0197	5.0	0.197	50	1.97
0.200	0.00787	0.60	0.0236	6.0	0.236	60	2.36
0.300	0.01181	0.70	0.0276	7.0	0.276	70	2.76
0.400	0.01575	0.80	0.0315	8.0	0.315	80	3.15
0.500	0.01969	0.90	0.0354	9.0	0.354	90	3.54
0.600	0.02362	1.00	0.0394	10.0	0.394	100	3.94
0.700	0.02756	2.00	0.0787	20.0	0.787		
0.800	0.03150	3.00	0.1181	30.0	1.181		
0.900	0.03543	4.00	0.1575	40.0	1.575		
1.000	0.03937	5.00	0.1969	50.0	1.969		
2.000	0.07874	6.00	0.2362	60.0	2.362		
3.000	0.11811	7.00	0.2756	70.0	2.756		
4.000	0.15748	8.00	0.3150	80.0	3.150		
5.000	0.19685	9.00	0.3543	90.0	3.543		
6.000	0.23622	10.00	0.3937	100.0	3.937		
7.000	0.27559	20.00	0.7874				
8.000	0.31496	30.00	1.1811				
9.000	0.35433	40.00	1.5748				
10.000	0.39370	50.00	1.9685				
20.000	0.78740	60.00	2.3622				
30.000	1.18110	70.00	2.7559				
40.000	1.57480	80.00	3.1496				
50.000	1.96850	90.00	3.5433				
60.000	2.36220	100.00	3.9370				
70.000	2.75591						
80.000	3.14961						
90.000	3.54331						
100.000	3.93701						

# Tightening Torque

## Nm-to-lb·ft (ft·lb)

To calculate: Nm x 0.738 = lb·ft

Nm	lb·ft (ft·lb)	Nm	lb·ft (ft·lb)	Nm	lb·ft (ft·lb)
10	7	55	41	100	74
11	8	56	41	105	77
12	9	57	42	110	81
13	10	58	43	115	85
14	10	59	44	120	89
15	11	60	44	125	92
16	12	61	45	130	96
17	13	62	46	135	100
18	13	63	46	140	103
19	14	64	47	145	107
20	15	65	48	150	111
21	15	66	49	155	114
22	16	67	49	160	118
23	17	68	50	165	122
24	18	69	51	170	125
25	18	70	52	175	129
26	19	71	52	180	133
27	20	72	53	185	136
28	21	73	54	190	140
29	21	74	55	195	144
30	22	75	55	200	148
31	23	76	56	205	151
32	24	77	57	210	155
33	24	78	58	215	159
34	25	79	58	220	162
35	26	80	59	225	166
36	27	81	60	230	170
37	27	82	60	235	173
38	28	83	61	240	177
39	29	84	62	245	181
40	30	85	63	250	184
41	30	86	63	260	192
42	31	87	64	270	199
43	32	88	65	280	207
44	32	89	66	290	214
45	33	90	66	300	221
46	34	91	67	310	229
47	35	92	68	320	236
48	35	93	69	330	243
49	36	94	69	340	251
50	37	95	70	350	258
51	38	96	71	360	266
52	38	97	72	370	273
53	39	98	72	380	280
54	40	99	73	390	288
55	41	100	74	400	295

## Nm-to-lb-in (in·lb), kg·cm

To calculate: Nm x 8.85 = lb-in • Nm x 10.20 = kg·cm

Nm	lb-in (in·lb)	kg·cm	Nm	lb-in (in·lb)	kg·cm
1	9	10	26	230	265
2	18	20	27	239	275
3	27	31	28	248	286
4	35	41	29	257	296
5	44	51	30	266	306
6	53	61	31	274	316
7	62	71	32	283	326
8	71	82	33	292	337
9	80	92	34	301	347
10	89	102	35	310	357
11	97	112	36	319	367
12	106	122	37	327	377
13	115	133	38	336	387
14	124	143	39	345	398
15	133	153	40	354	408
16	142	163	41	363	418
17	150	173	42	372	428
18	159	184	43	381	438
19	168	194	44	389	449
20	177	204	45	398	459
21	186	214	46	407	469
22	195	224	47	416	479
23	204	235	48	425	489
24	212	245	49	434	500
25	221	255	50	443	510

## N·cm-to-lb-in (in·lb), kg·cm

To calculate: N·cm x 0.089 = lb-in • N·cm x 0.102 = kg·cm

N·cm	lb-in (in·lb)	kg·cm	N·cm	lb-in (in·lb)	kg·cm
50	4	5	250	22	25
60	5	6	300	27	31
70	6	7	350	31	36
80	7	8	400	35	41
90	8	9	450	40	46
100	9	10	500	44	51
110	10	11	550	49	56
120	11	12	600	53	61
130	12	13	650	58	66
140	12	14	700	62	71
150	13	15	750	66	76
160	14	16	800	71	82
170	15	17	850	75	87
180	16	18	900	80	92
190	17	19	950	84	97
200	18	20	1000	89	102

## kg·cm-to-lb·in (in·lb), N·cm

To calculate:  $\text{kg}\cdot\text{cm} \times 0.868 = \text{lb}\cdot\text{in}$  •  $\text{kg}\cdot\text{cm} \times 9.81 = \text{N}\cdot\text{cm}$

kg·cm	lb·in (in·lb)	N·cm		kg·cm	lb·in (in·lb)	N·cm
5	4	49		110	95	1079
6	5	59		120	104	1177
7	6	69		130	113	1275
8	7	78		140	122	1373
9	8	88		150	130	1471
10	9	98		160	139	1569
20	17	196		170	148	1667
30	26	294		180	156	1765
40	35	392		190	165	1863
50	43	490		200	174	1961
60	52	588		210	182	2059
70	61	686		220	191	2157
80	69	785		230	200	2256
90	78	883		240	208	2354
100	87	981		250	217	2452

## Warnings and Cautions

### WARNINGS

- Some repairs may be beyond your capability. If you lack the skills, tools and equipment, or a suitable workplace for any procedure described in this manual, we suggest you leave such repairs to an authorized dealer service department or other qualified shop.
- Do not reuse any fasteners that have become worn or deformed during normal use. Many fasteners are designed to be used only once and become unreliable and may fail when used a second time. This includes, but is not limited to, nuts, bolts, washers, self-locking nuts or bolts, circlips and cotter pins. Always replace these fasteners with new parts.
- Never work under a lifted car unless it is solidly supported on stands designed for the purpose. Do not support a car on cinder blocks, hollow tiles or other props that may crumble under continuous load. Never work under a car that is supported solely by a jack. Never work under the car while the engine is running.
- If you are going to work under a car on the ground, make sure the ground is level. Block the wheels to keep the car from rolling. Disconnect the battery negative (-) terminal (ground strap) to prevent others from starting the car while you are under it.

- Never run the engine unless the work area is well ventilated. Carbon monoxide kills.
- Remove rings, bracelets and other jewelry so they cannot cause electrical shorts, get caught in running machinery, or be crushed by heavy parts.
- Tie back long hair. Do not wear a necktie, a scarf, loose clothing, or a necklace when you work near machine tools or running engines. If your hair, clothing, or jewelry were to get caught in the machinery, severe injury could result.
- Do not attempt to work on your car if you do not feel well. You increase the danger of injury to yourself and others if you are tired, upset, or have taken medication or any other substance that may keep you from being fully alert.
- Illuminate your work area adequately but safely. Use a portable safety light for working inside or under the car. Make sure the bulb is enclosed by a wire cage. The hot filament of an accidentally broken bulb can ignite spilled fuel, vapors or oil.
- Use a suitable container to catch draining fuel, oil, or brake fluid. Do not use food or beverage containers that might mislead someone into drinking from them. Store flammable fluids away from fire hazards. Wipe up spills at once, but do not store oily rags which can ignite and burn spontaneously.
- Always observe good workshop practices. Wear goggles when you operate machine tools or work with battery acid. Wear gloves or other protective clothing whenever the job requires working with harmful substances.
- Greases, lubricants and other automotive chemicals contain toxic substances, many of which are absorbed directly through the skin. Read the manufacturer's instructions and warnings carefully. Use hand and eye protection. Avoid direct skin contact
- Disconnect the battery negative (-) terminal (ground strap) whenever you work on the fuel or electrical system. Do not smoke or work near heaters or other fire hazards. Keep an approved fire extinguisher handy.
- Friction materials (such as brake pads or shoes or clutch discs) contain asbestos fibers or other friction materials. Do not create dust by grinding, sanding, or cleaning with compressed air. Avoid breathing dust. Breathing any friction material dust can lead to serious diseases and may result in death.

*(WARNINGS cont'd on next page)*

## **WARNINGS** *(cont'd)*

- Batteries give off explosive hydrogen gas during charging. Keep sparks, lighted matches and open flame away from the top of the battery. If hydrogen gas escaping from the cap vents is ignited, it ignites the gas trapped in the cells and causes the battery to explode.
- Connect and disconnect battery cables, jumper cables or a battery charger only with the ignition off. Do not disconnect the battery while the engine is running.
- Do not quick-charge the battery (for boost starting) for longer than one minute. Wait at least one minute before boosting the battery a second time.
- Do not allow battery charging voltage to exceed 16.5 volts. If the battery begins producing gas or boiling violently, reduce the charging rate. Boosting a sulfated battery at a high charging rate can cause an explosion.
- The A/C system is filled with chemical refrigerant, which is hazardous. The A/C system should be serviced only by trained technicians using approved refrigerant recovery/recycling equipment, trained in related safety precautions, and familiar with regulations governing the discharging and disposal of automotive chemical refrigerants.
- Do not expose any part of the A/C system to high temperatures such as open flame. Excessive heat increases system pressure and may cause the system to burst.
- Some aerosol tire inflators are highly flammable. Be extremely cautious when repairing a tire that may have been inflated using an aerosol tire inflator. Keep sparks, open flame or other sources of ignition away from the tire repair area. Inflate and deflate the tire at least four times before breaking the bead from the rim. Completely remove the tire from the rim before attempting any repair.
- Some cars are equipped with a Supplemental Restraint System (SRS) that automatically deploys airbags and pyrotechnic seat belt tensioners in the event of a frontal or side impact. These are explosive devices. Handled improperly or without adequate safeguards, they can be accidentally activated and cause serious injury.
- The ignition system produces high voltages that can be fatal. Avoid contact with exposed terminals and use extreme care when working on a car with the engine running or the ignition on.



- Place jack stands only at locations specified by manufacturer. The vehicle lifting jack supplied with the vehicle is intended for tire changes only. Use a heavy duty floor jack to lift the vehicle before installing jack stands.
- Battery acid (electrolyte) can cause severe burns. Flush contact area with water, seek medical attention.
- Aerosol cleaners and solvents may contain hazardous or deadly vapors and are highly flammable. Use only in a well ventilated area. Do not use on hot surfaces (such as engines or brakes).
- Do not remove coolant reservoir or radiator cap with the engine hot. Burns and engine damage may occur.

## CAUTIONS

- If you lack the skills, tools and equipment, or a suitable workshop for any procedure described in this manual, we suggest you leave such repairs to an authorized dealer or other qualified shop.
- Before starting a job, make certain that you have all the necessary tools and parts on hand. Read all the instructions thoroughly and do not attempt shortcuts. Use tools appropriate to the work and use only replacement parts meeting original specifications. Makeshift tools, parts and procedures will not make good repairs.
- Use pneumatic and electric tools only to loosen threaded parts and fasteners. Never use these tools to tighten fasteners, especially on light alloy parts. Always use a torque wrench to tighten fasteners to the tightening torque specification listed.
- Be mindful of the environment and ecology. Before you drain the crankcase, find out the proper way to dispose of the oil. Do not pour oil onto the ground, down a drain, or into a stream, pond or lake. Dispose of in accordance with Federal, State and Local laws.
- The control module for the Anti-lock Brake System (ABS) cannot withstand temperatures from a paint-drying booth or a heat lamp in excess of 95°C (203°F) and should not be subjected to temperatures exceeding 85°C (185°F) for more than two hours.
- Before doing any electrical welding on cars equipped with ABS, disconnect the battery negative (-) terminal (ground strap) and the ABS control module connector.

*(CAUTIONS cont'd on next page)*

## **CAUTIONS** *(cont'd)*

- Always make sure the ignition is off before disconnecting battery
- Label battery cables before disconnecting. On some models, battery cables are not color coded.
- Disconnecting the battery may erase fault code(s) stored in control module memory. Check for fault codes prior to disconnecting the battery cables.
- If a normal or rapid charger is used to charge the battery, disconnect the battery and remove it from the vehicle to avoid damaging paint and upholstery.
- Do not quick-charge the battery (for boost starting) for longer than one minute. Wait at least one minute before boosting the battery a second time.
- Connect and disconnect a battery charger only with the battery charger switched off.
- Sealed or “maintenance free” batteries should be slow-charged only, at an amperage rate that is approximately 10% of the battery’s ampere-hour (Ah) rating.
- Do not allow battery charging voltage to exceed 16.5 volts. If the battery begins producing gas or boiling violently, reduce the charging rate. Boosting a sulfated battery at a high charging rate can cause an explosion.

# VEHICLE IDENTIFICATION

## Vehicle Identification Number (VIN) Location

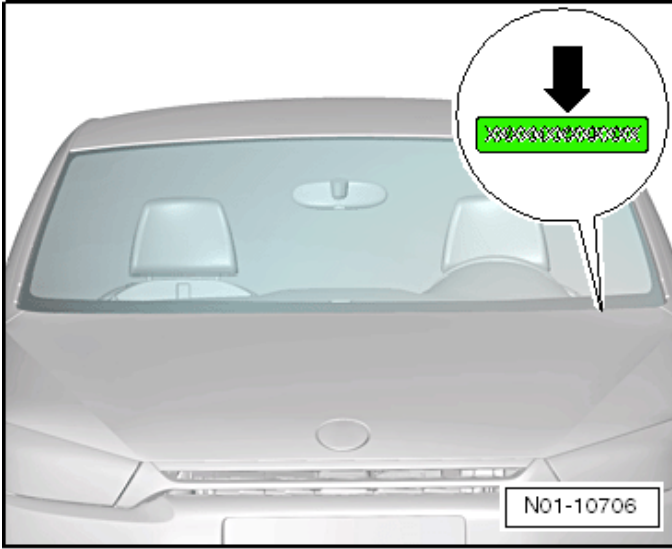

Vehicle  
Identification

The VIN (➡) is on the left side of the vehicle in the area of the windshield wiper mount. It is visible from the outside.  
(Typical illustration shown).

# VIN Decoder

## 2013 Volkswagen VIN Decoder (except Routan)

Country of origin	Manufacturer	Vehicle Type	Series	Engine	Restraint system	Model (7 & 8)	Check digit	Model year	Assembly plant	Sequential production number (position 12 - 17)							
1	2	3	4	5	6	7	8	9	10	11	12	13	14	15	16	17	
W	V	V	B	P	7	A	N	8	D	E	5	0	2	0	1	3	
<p><b>Series:</b></p> <p>A= CC Sport w/Man Trans, Golf Zdr w/5 Spd Manual, Passat S, Tiguan w/Auto Trans</p> <p>B= CC Sport/Sport w/Auto Trans, Eos Kombi/Sport w/Auto Trans, Golf Zdr w/Auto Trans, Jetta SE w/5 Spd Man, Passat SE, Tiguan w/Auto Trans and 4-Motion</p> <p>C= Golf Zdr w/5 Spd Manual, Passat SEL, Tiguan w/Man Trans</p> <p>D= Golf Zdr w/Auto Trans, Jetta SE w/Auto Trans</p> <p>E= GTI Zdr w/Man Trans, Touareg V6 FSI/ TDI /Hybrid</p> <p>F= Beetle w/6 Spd Auto Trans, Eos Lux/Exec w/Auto Trans, GTI Zdr w/Auto Trans</p> <p>G= CC V6 Exec w/Auto Trans and 4Motion, GTI 4dr w/Man Trans, Jetta SEL w/5 Spd Man Trans</p> <p>H= CC V6 Lux w/Auto Trans, Beetle 2.5L TDI w/5 Spd Manual, GTI 4dr w/Auto Trans</p> <p>J= Beetle 2.5L TDI w/6 Spd</p> <p>K= Jetta SportWagen w/5 Spd Man Trans</p> <p>L= Jetta SEL/TDI w/Auto Trans</p> <p>M= Golf Zdr w/6 Spd Manual, Jetta SportWagen w/6 Spd Manual</p> <p>N= Golf Zdr w/6 Spd Manual</p> <p>P= Golf R 4dr w/Man Trans, Jetta SportWagen w/6 Spd Auto Trans</p> <p>R= Beetle TDI w/6 Spd Man, CC Lux w/Auto Trans, Golf R Zdr w/Man Trans</p> <p>S= Beetle Turbo w/6 Spd Auto Trans</p> <p>T= Jetta / S w/5 Spd Manual</p> <p>2= Jetta / S w/Auto Trans</p> <p>3= Jetta TDI w/6 Spd Man</p> <p>4= Beetle Turbo w/6 Spd Manual, Jetta GLI w/Auto Trans</p> <p>5= Beetle Conv. 2.5 L TDI w/6 Spd. Auto Trans, Jetta GLI w/6 Spd Manual</p> <p>6= Beetle Conv. TDI w/6 Spd Man Trans, Jetta Hybrid w/Auto Trans</p> <p>7= Beetle Conv. Turbo w/6 Spd Auto Trans</p> <p>8= Beetle Conv. Turbo w/6 Spd Man Trans</p>											<p><b>D = 2013</b></p> <p>Sequential production number (position 12 - 17)</p>						
<p><b>WWV</b> = Europe - Pass. Car  <b>VWV</b> = USA - Pass. Car  <b>3WV</b> = Mexico - Pass. Car  <b>VWV</b> = Europe - S.U.V.</p>											<p><b>A3**</b> = Passat  <b>AH (1F)</b> = Eos  <b>AJ (16)***</b> = Golf, Golf R, GTI, Jetta, Jetta SportWagen  <b>AN (3C)</b> = CC  <b>AT</b> = Beetle, Beetle Conv.  <b>AX (5N)</b> = Tiguan  <b>BP (7P)</b> = Touareg</p>						
<p><b>C</b> = Chattanooga  <b>D</b> = Bratislava  <b>E</b> = Emden  <b>M</b> = Mexico</p>											<p><b>P</b> = Mosel  <b>V</b> = Portugal  <b>W</b> = Wolfsburg</p>						
<p><b>* PZEV</b> = Partial Zero Emissions Vehicle  <b>** SULEV</b> = Super Low Emissions Vehicle  <b>***</b> 7 position US model characters are alphabetic beginning with 2010 MY. RCW model characters, where different, are listed in parenthesis (), for reference only.  <b>****</b> Jetta and Jetta SportWagen models are identified by WMI code of <b>3WV</b>, <b>GTI</b> and <b>Golf</b> models are identified by WMI code of <b>WWV</b>.</p>											<p><b>A=</b> 4 cyl 2.0L 200hp (CBFA-PZEV) Beetle, Beetle Convertible, Jetta, Jetta GLI  <b>B=</b> 5 cyl 2.5L 170hp (CBTA-M) Golf  <b>B=</b> 5 cyl 2.5L 170hp (CBTA-M-PZEV) Golf  <b>D=</b> 4 cyl 2.0L 200hp (CBFA-M-PZEV) GTI  <b>D=</b> 4 cyl 2.0L 200hp (CCTA) Eos  <b>F=</b> 4 cyl 2.0L 256hp (CRZA) Golf R  <b>F=</b> VR6 3.6L 280hp (CGRK) Touareg  <b>G=</b> 5 cyl 3.0L 333hp + 34 Kw (CQFA) Touareg Hybrid  <b>H=</b> 5 cyl 2.5L 170hp (CBTA-M) Passat  <b>K=</b> 4 cyl 2.0L 115hp (CBPA) Passat  <b>L=</b> 4 cyl 2.0L TDI 140hp (CJAA) Jetta, Jetta SportWagen, Beetle, Beetle Convertible  <b>M=</b> 4 cyl 2.0L TDI 140hp (CJAA) Golf  <b>M=</b> VR6 3.6L 280hp (CCTB) Passat  <b>N=</b> 4 cyl 2.0L 200hp (CCTA) CC  <b>N=</b> 4 cyl 2.0L TDI 140hp (CKRA) Passat  <b>P=</b> 4 cyl 2.0L 200hp (CBFA-PZEV) CC  <b>P=</b> 5 cyl 2.5L 170hp (CBFA-M-PZEV) Beetle, Beetle Convertible, Jetta, Jetta SportWagen, Passat  <b>P=</b> VR6 3.0L TDI 240hp (CNRB) Touareg  <b>P=</b> VR6 3.6L 280hp (CJAA) CC  <b>V=</b> 4 cyl 2.0L 200hp (CCTA) GTI, Tiguan  <b>W=</b> 4 cyl 2.0L 200hp (CBFA-SULEV) Eos  <b>X=</b> 5 cyl 2.5L 170hp (CBTA-M) Beetle, Beetle Convertible, Jetta, Jetta SportWagen  <b>3=</b> 4 cyl 1.4L 150hp + 28 Kw (CNLA) Jetta Hybrid  <b>6=</b> 4 cyl 2.0L 200hp (CCTA) Beetle, Beetle Convertible, Jetta GLI</p>						

October 1, 2012 (Rev 4)

Country of origin	Manufacturer	Vehicle Type	Series	Engine	Restraint system	Model (position 7 & 8)	Check digit	Model year	Assembly plant	Sequential production number (position 12 - 17)							
M	V	V	B	P	7	A	N	8	D	E	5	0	2	0	1	3	
<p><b>2013 Restraint System:</b></p> <p>All = Active-Dri-Pass - Front Air Bag - Dri-Pass</p> <p>7 = Advanced Front Air Bags + Side Impact Air Bags - Front + Side Curtain Air Bags</p> <p>8 (Eos Only) = Advanced Front Air Bags + Side Impact Air Bags - Front + Knee Air Bags - Front + Side Curtain Air Bags</p> <p>8 (Jetta Only) or 8 (All Others) = Advanced Front Air Bags + Side Impact Air Bags - Fr.Rr. + Side Curtain Air Bags</p> <p>9 (Tiguan) = Advanced Front Air Bags + Side Impact Air Bags - Fr. Rr. + Side Curtain Air Bags</p> <p>9 (Touareg) = Advanced Front Air Bags + Side Impact Air Bags - Front + Side Curtain Air Bag</p>											<p><b>Calculate per NHTSA Code</b></p>						
<p><b>Sequential Product Number</b></p>											<p><b>Sequential production number (position 12 - 17)</b></p>						
<p><b>M = 1991</b>  <b>N = 1992</b>  <b>P = 1993</b>  <b>R = 1994</b>  <b>S = 1995</b>  <b>T = 1996</b>  <b>V = 1997</b>  <b>W = 1998</b>  <b>X = 1999</b>  <b>Y = 2000</b>  <b>1 = 2001</b>  <b>2 = 2002</b>  <b>3 = 2003</b>  <b>4 = 2004</b>  <b>5 = 2005</b>  <b>6 = 2006</b>  <b>7 = 2007</b>  <b>8 = 2008</b>  <b>9 = 2009</b>  <b>A = 2010</b>  <b>B = 2011</b>  <b>C = 2012</b>  <b>D = 2013</b></p>											<p><b>2013 Volkswagen VIN Decoder (except Routan)</b></p>						

## Vehicle Data Label Location

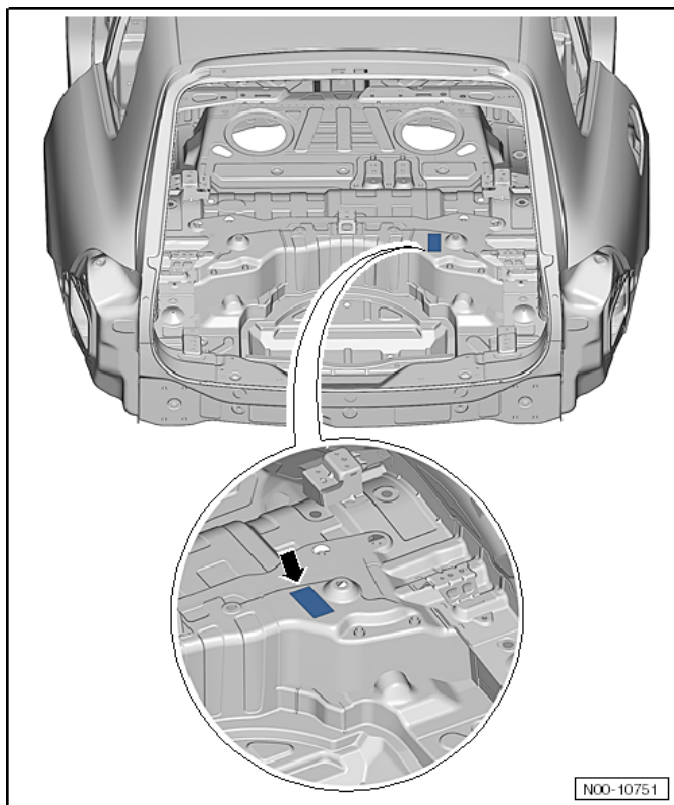

The vehicle data label (➡) is above the right spare wheel well.

Vehicle  
Identification

# SALES CODES

## Engine Codes

<b>CNRB</b>	3.0L 6-cylinder TDI
<b>CGFA</b>	3.0L 6-cylinder
<b>CGRA</b>	3.6L 6-cylinder

## Transmission Codes

<b>0C8</b>	8-speed automatic transmission
------------	--------------------------------

# VEHICLE LIFTING

## *Hoist and Jack Mounting Points*

Front

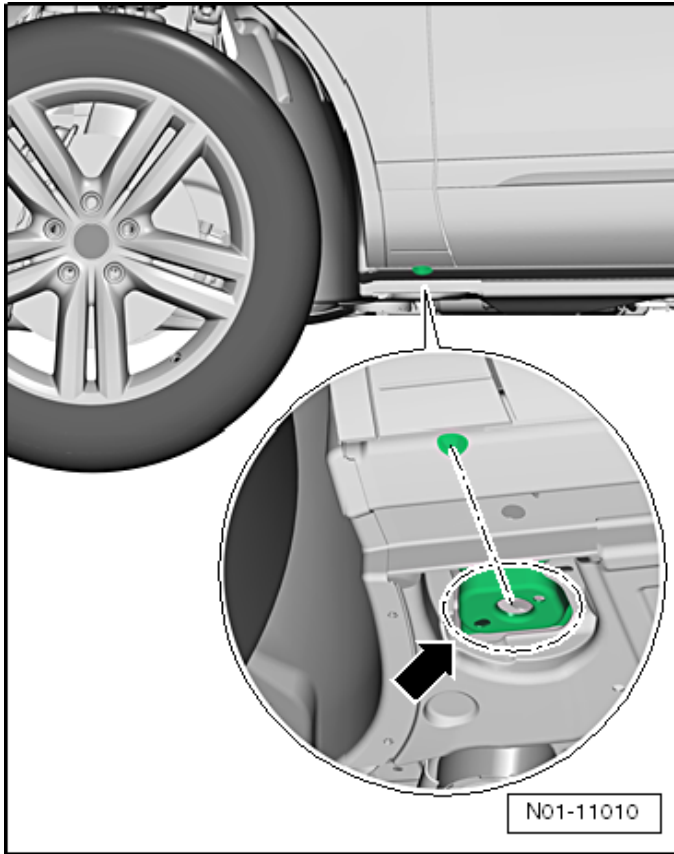

Position the support plate on the floor plate longitudinal reinforcement (➡).



### **WARNING**

Never raise the front of the vehicle by the side member vertical stiffener.

Sales  
Codes

Vehicle  
Lifting

## Rear

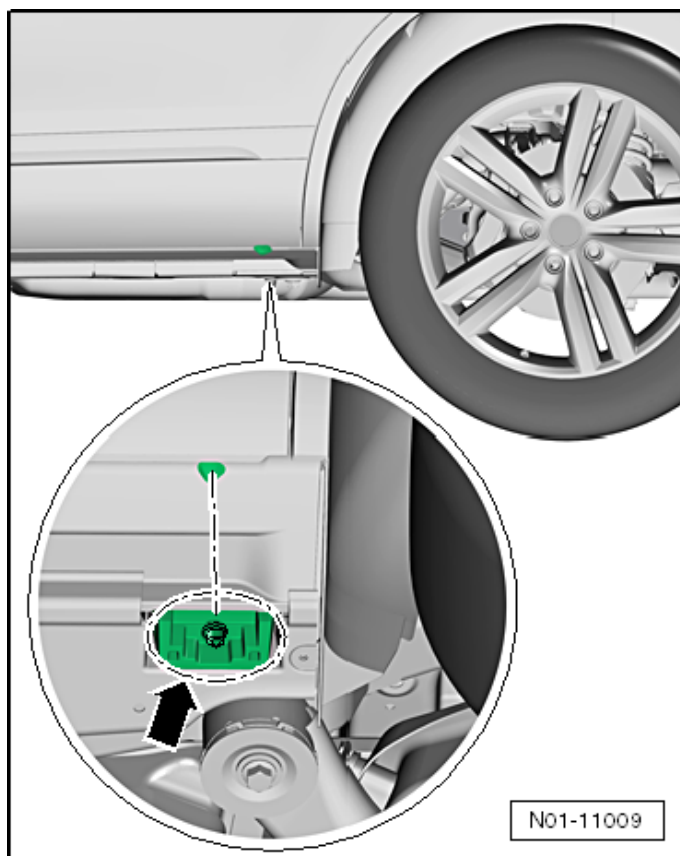

Position the support plate on the floor plate reinforcement near the rear axle (➡).



# ENGINE MECHANICAL – 3.0L CNRB (TDI)

## *General, Technical Data*

### Engine Number Location

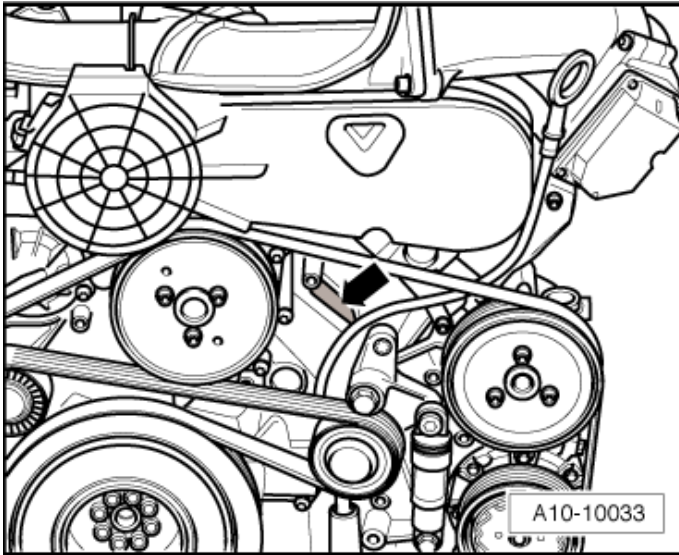

The engine number (engine code and serial number) is located on the left front side under the high pressure pump toothed belt (➔).

The first 3 digits of the engine code indicate the displacement and mechanical structure of the engine. The fourth digit describes the engine output and torque.

## Engine Data

Engine code		CNRB
Manufactured		from 05.12
Emission values in accordance with		BIN5/ULEV2
Displacement	liter	3.0
Output	kW at RPM	176 @ 4000
Torque	Nm at RPM	550 @ 2100
Bore	diameter mm	83.0
Stroke	mm	91.4
Compression ratio		16.8
Fuel	conforms to	---
Ignition sequence		1-4-3-6-2-5
Exhaust Gas Recirculation (EGR)		Yes
Turbocharger, Supercharger		Turbocharger
Catalytic converter		Yes
Particulate filter		Yes
Charge Air Cooler (CAC)		Yes
Oxygen Sensor (O2S) regulation		Yes
Valves per cylinder		4
Selective Catalytic Reduction (SCR) system		Yes

# Engine Assembly – 3.0L CNRB (TDI)

## Fastener Tightening Specifications

Component	Fastener size	Nm
Bolts and nuts	M6	10
	M7	15
	M8	25
	M10	40
	M12	60
Electrohydraulic engine mount solenoid valve to bracket bolt <sup>1)</sup>	-	5
Engine mount bolts <sup>1)</sup>	-	60
Engine mount to engine support nut	-	75
Engine support to frame bolt	-	120 plus an additional 180° (½ turn)
Engine support to engine block bolt <sup>1)</sup>	-	50 plus an additional 90° (¼ turn)
Ground cable to right engine support	-	15
Vacuum reservoir to bracket bolt	-	205
Vacuum reservoir and electrohydraulic engine mount solenoid valve bracket	-	9

<sup>1)</sup> For bolt tightening clarification, refer to ElsaWeb, *Subframe Overview*, items 13 and 19.

# Crankshaft, Cylinder Block – 3.0L CNRB (TDI)

## Allocation of Crankshaft Bearing Shells for Cylinder Block

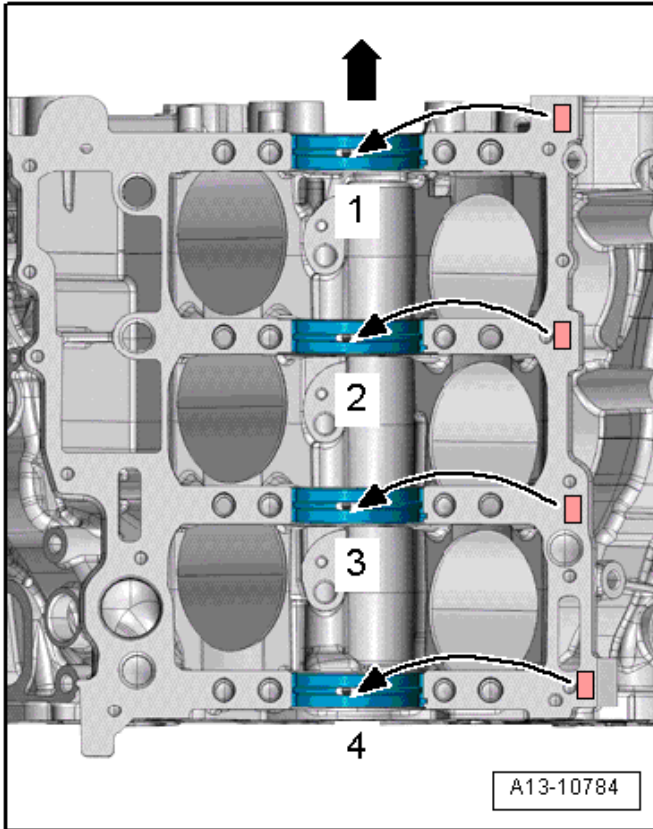

Bearing shells with the correct thickness are allocated to the cylinder block in the factory. Colored dots on the bearing shells identify bearing shell thickness. The ➡ points to the belt pulley side. The allocation of the bearing shells to the cylinder block is identified with a letter by each bearing.

Letter on cylinder block	Color of bearing
R	Red
G	Yellow
B	Blue

## Allocation of Crankshaft Bearing Shells for Guide Frame

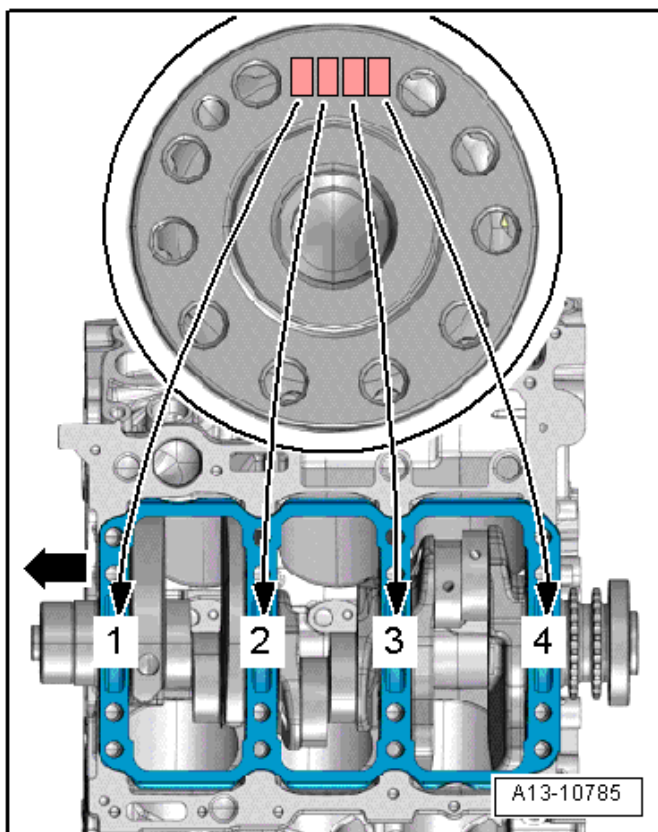

Bearing shells with the correct thickness are allocated to the bearing cap at the factory. Colored dots on sides of bearing shells serve for identifying bearing shell thickness. Allocation of bearing shells to guide frame is marked on flywheel flange of crankshaft by a row of letters. The first letter of the row of letters represents bearing “1” the second letter is for bearing “2”, etc.

Letter on crankshaft	Color of bearing
R	Red
G	Yellow
B	Blue

## Fastener Tightening Specifications

Component	Fastener Size	Nm
A/C compressor bracket to cylinder block bolt <sup>1)</sup>	-	40
Balance shaft bolt	-	60
Balance shaft gear carrier bolt <sup>3)</sup>	-	9
Belt tensioner bolt	M10	50 plus an additional 90° (¼ turn)
	M11	60 plus an additional 90° (¼ turn)
Connecting rod bearing cap to connecting rod bolt <sup>2)</sup>	-	35 plus an additional 90° (¼ turn)
Drive chain sprocket bolt	-	23
Drive plate to crankshaft bolt <sup>2)</sup>	-	60 plus an additional 90° (¼ turn)
Generator bracket bolt <sup>1)</sup>	-	40
Idler roller bolt	-	23
Oil spray jet	-	9
Oil temperature sensor 2 bolt	-	9
Vibration damper bolt <sup>2)</sup>	-	20 plus an additional 90° (¼ turn)

<sup>1)</sup> Tighten the bolts in a diagonal sequence and in stages.

<sup>2)</sup> Replace fastener(s).

<sup>3)</sup> Insert with locking compound.

## Ribbed Belt Pulley Side Sealing Flange Tightening Specification

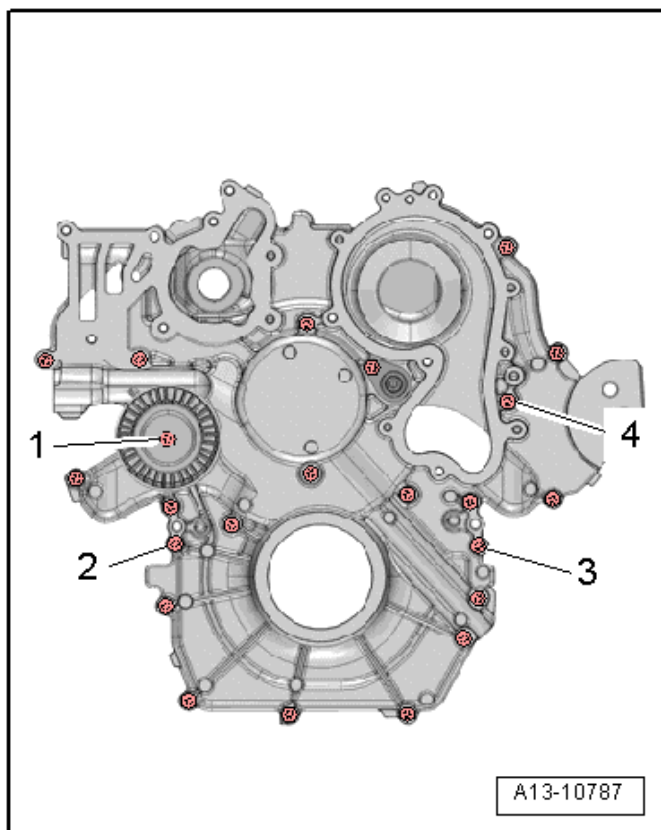

Replace the bolts that have been tightened to additional torque. There is a risk of damaging the aluminum bolts when installing the sealing flange. Aluminum bolts must not be used to tighten the sealing flange to the cylinder block. Therefore prepare 3 M6x20 steel bolts to tighten the sealing flange as instructed as follows. Tighten the bolts in 10 steps in the sequence shown.

Step	Bolts	Nm
1	Tighten bolts in a diagonal sequence	Attach the sealing flange with the seal to the cylinder block
2	1	23
3	2, 3, 4	M6 x 20 to 9 Nm

## Ribbed Belt Pulley Side Sealing Flange Tightening Specification (cont'd)

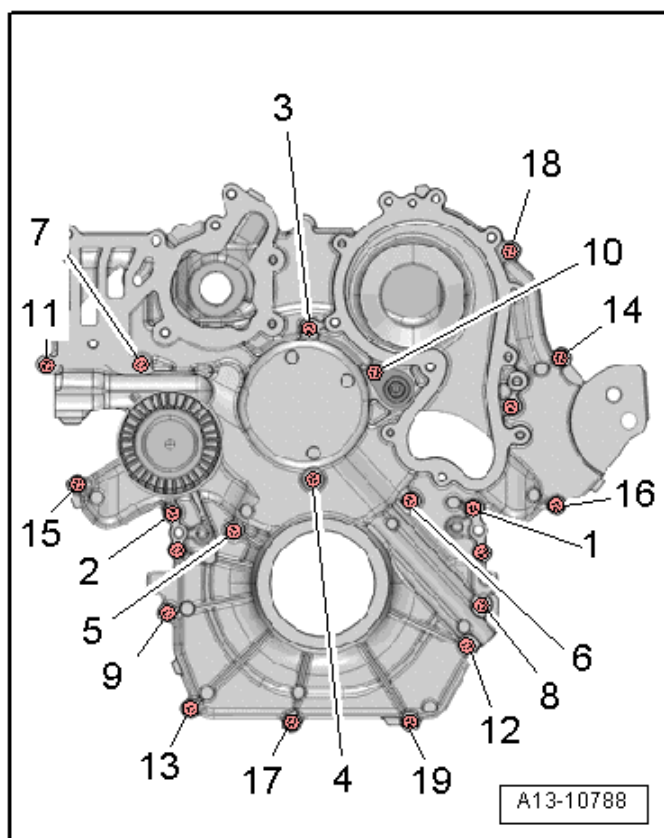

Step	Bolts	Nm
4		Insert a temperature regulator for the engine oil cooler with the cover
5	10	Install all the way in by hand.
6	1 through 19	3 Nm
7	1 through 19	3 Nm - this measurement accounts for the seal shrinkage
8	1 through 19	Tighten an additional turn 90°



## Ribbed Belt Pulley Side Sealing Flange Tightening Specification (cont'd)

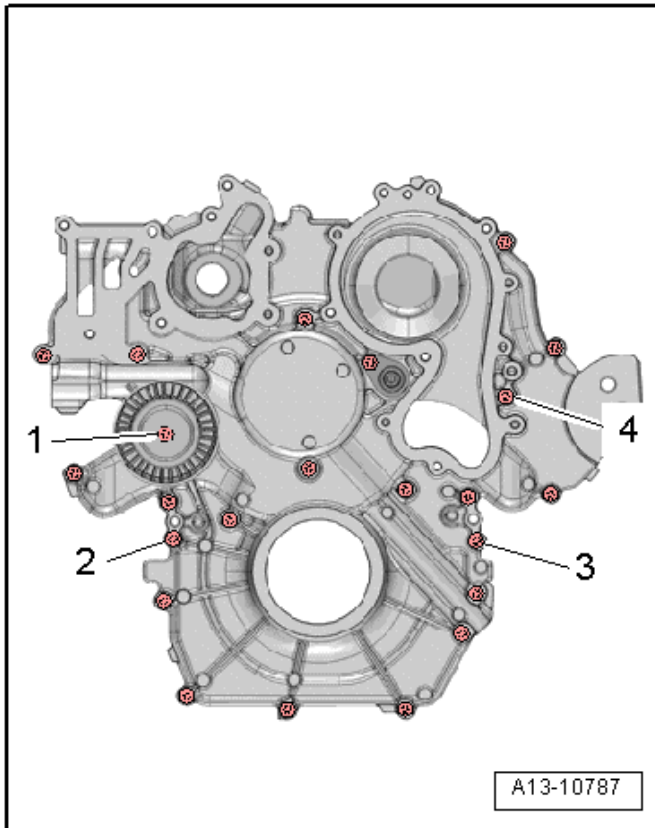

Step	Bolts	Nm
9	2, 3, 4	Remove the steel bolts M6 x 20
10	2, 3, 4	Insert the aluminum bolts and tighten to 3 Nm
11	2, 3, 4	Turn the aluminum bolts 90° further

## Guide Frame Tightening Specifications

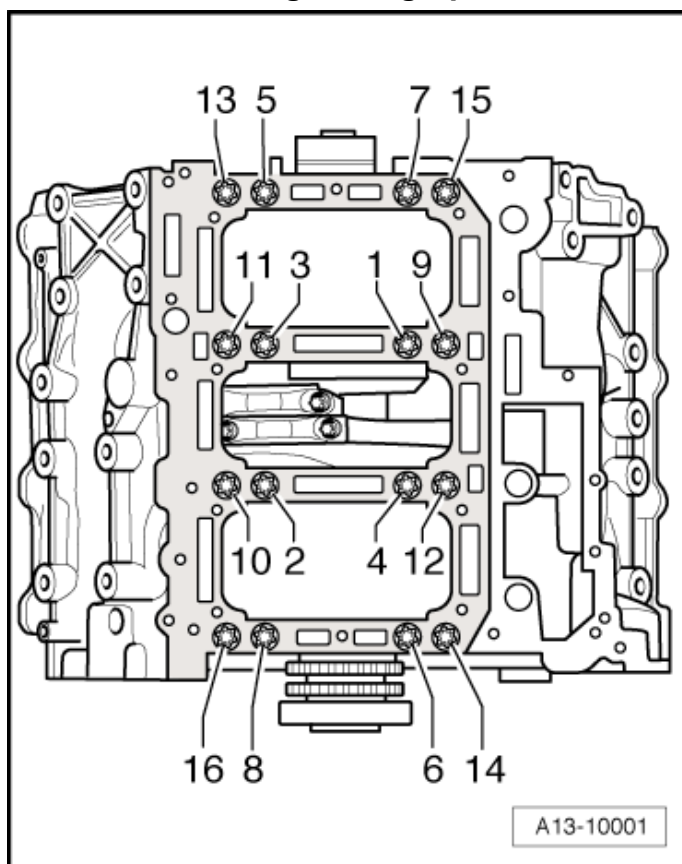

Step	Component	Nm
1	Tighten bolts 1 through 16 in sequence <sup>1)</sup>	30
2	Tighten bolts 1 through 16 in sequence	50
3	Tighten bolts 1 through 16 in sequence	an additional 180° (½ turn)

<sup>1)</sup> Replace fastener(s).

## Crankshaft Dimensions

Honing dimension in mm	Crankshaft bearing pin diameter		Crankshaft connecting rod journal diameter	
Basic dimension	65.00	-0.022	60.00	-0.022
		-0.042		-0.042

## Piston and Cylinder Dimensions

Honing dimensions in mm	Piston diameter	Cylinder bore diameter
Basic dimension	82.924 to 82.936 <sup>1)</sup>	83.006 to 83.014 <sup>2)</sup>
Repair stage	82.964 to 82.976 <sup>1)</sup>	83.046 to 83.054 <sup>2)</sup>

<sup>1)</sup> Measurements without graphite coating (thickness = 0.02 mm). The graphite coating wears off.

<sup>2)</sup> Measure 50 mm inside the cylinder bore.

## Piston Ring End Gaps

Piston ring dimensions in mm	New	Wear limit
1 <sup>st</sup> compression ring	0.25 to 0.40	0.60
2 <sup>nd</sup> compression ring	0.70 to 0.90	1.20
Oil scraping ring	0.25 to 0.50	0.70

## Piston Ring Clearance

Piston ring dimensions in mm	New	Wear limit
1 <sup>st</sup> compression ring	0.009 to 0.130	0.160
2 <sup>nd</sup> compression ring	0.05 to 0.09	0.11
Oil scraping ring	0.03 to 0.09	0.10

# Cylinder Head, Valvetrain – 3.0L CNRB (TDI)

## Fastener Tightening Specifications

Component	Nm
Camshaft chain sprocket bolt	23
Chain tensioner bolt	5 plus an additional 90° (¼ turn)
Engine lifting eye bolt	23
Heat shield bolt	9
Oil pump drive chain sprocket bolt <sup>3)</sup>	30 plus an additional 45° (⅛ turn)
Oil pump drive chain tensioner	5 plus an additional 90° (¼ turn)
Oil pump drive chain glide track guide pin	5 plus an additional 90° (¼ turn)
Tensioning rail guide pin	23
Timing chain guide rail pin <sup>1)</sup>	5 plus an additional 90° (¼ turn)
Timing chain guide rail pin <sup>2)</sup>	23

<sup>1)</sup> For bolt tightening clarification, refer to ElsaWeb, *Camshaft Timing Chain Overview*, items 6 and 16.

For bolt tightening clarification, refer to ElsaWeb, *Camshaft Timing Chain Overview*, item 13.

<sup>3)</sup> Replace fastener(s).

## Valve Dimensions

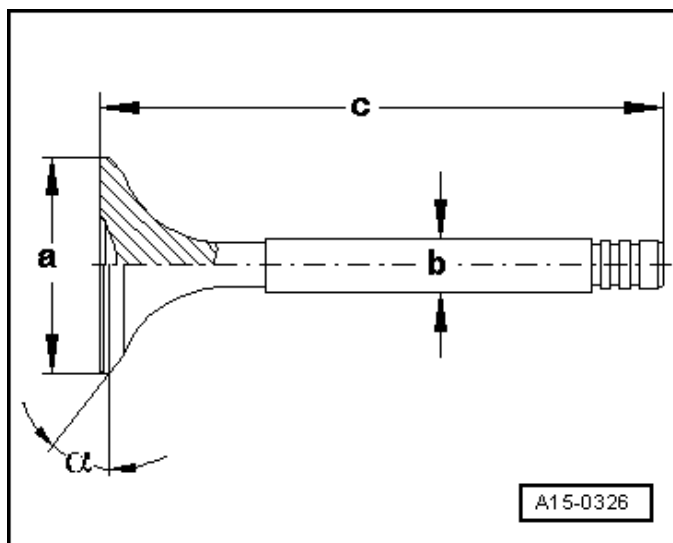

Dimension		Intake valve	Exhaust valve
Diameter a	mm	28.5 to 28.7	25.9 to 26.1
Diameter b	mm	5.968 to 5.982	5.958 to 5.972
c	mm	97.2 to 97.4	99.0 to 99.2
$\alpha$	$^{\circ}$	$45^{\circ} 10'$	$45^{\circ} 10'$

NOTE: Intake and exhaust valves must not be refaced by grinding. Only lapping is permitted.

## Compression Pressures

Compression pressure	Bar pressure
New	28 to 33
Wear limit	21
Maximum difference between cylinders	5

## Left Cylinder Head Cover Tightening Specifications

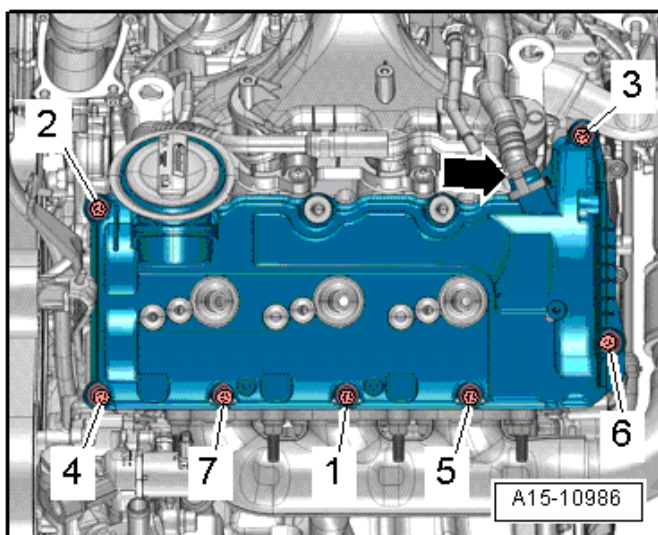

Replace the bolts that have been tightened to additional torque.

Step	Component	Nm
1	Tighten bolts 1 through 7 in sequence	Hand-tighten
2	Tighten bolts 1 through 7 in sequence	8
3	Tighten bolts 1 through 7 in sequence	an additional 90° (¼ turn)

## Right Cylinder Head Cover Tightening Specifications

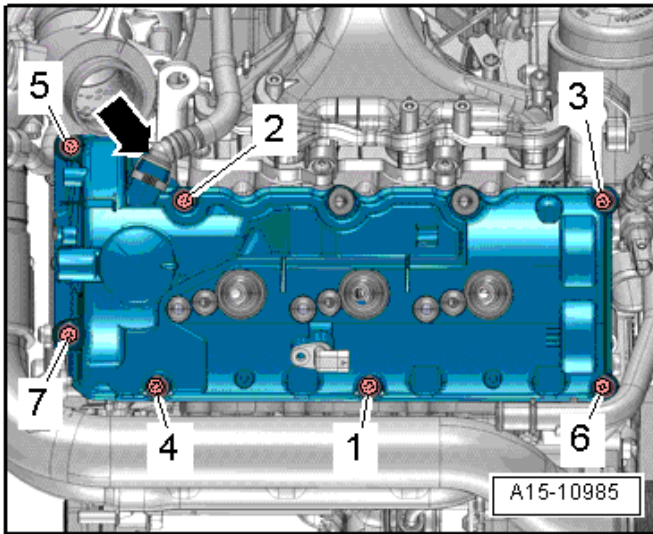

Replace the bolts that have been tightened to additional torque.

Step	Component	Nm
1	Tighten bolts 1 through 7 in sequence	Hand-tighten
2	Tighten bolts 1 through 7 in sequence	8
3	Tighten bolts 1 through 7 in sequence	an additional 90° (¼ turn)

## Cylinder Head Tightening Specifications

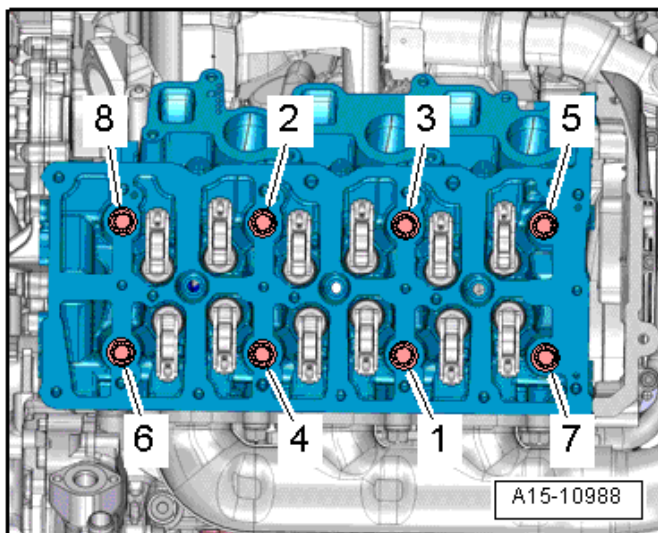

Replace the bolts that have been tightened to additional torque.

Step	Component	Nm
1	Tighten bolts 1 through 8 in sequence	Hand-tighten
2	Tighten bolts 1 through 8 in sequence	35
3	Tighten bolts 1 through 8 in sequence	60
4	Tighten bolts 1 through 8 in sequence	an additional 90° (¼ turn)
5	Tighten bolts 1 through 8 in sequence	an additional 90° (¼ turn)



## Upper Timing Chain Cover Tightening Specifications

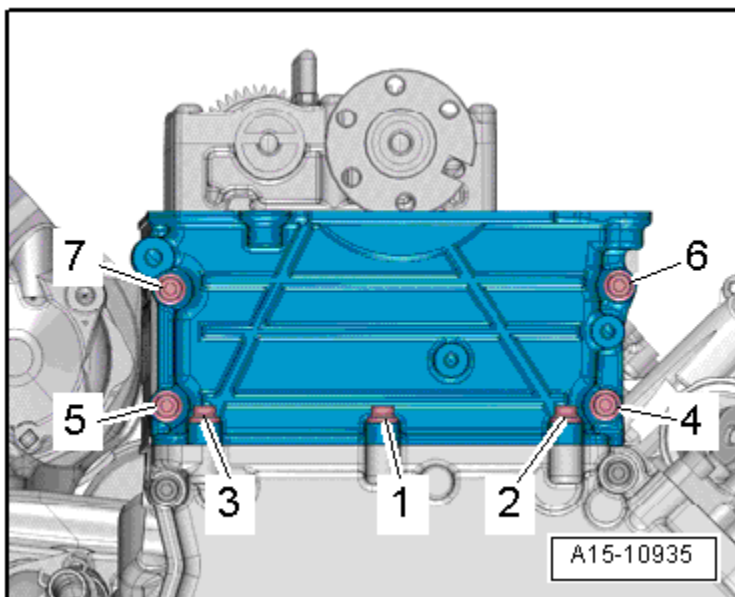

Replace the bolts that have been tightened to additional torque

Step	Component	Nm
1	Tighten bolts 1 through 3 in sequence	Hand-tighten
2	Tighten bolts 4 through 7 in sequence	Hand-tighten
3	Tighten bolts 1 through 7 in sequence	8
4	Tighten bolts 1 through 7 in sequence	8 Nm - this measurement takes into account the timing chain guard shrinkage.
5	Tighten bolts 1 through 7 in sequence	an additional 90° (¼ turn)

## Lower Timing Chain Cover Tightening Specifications

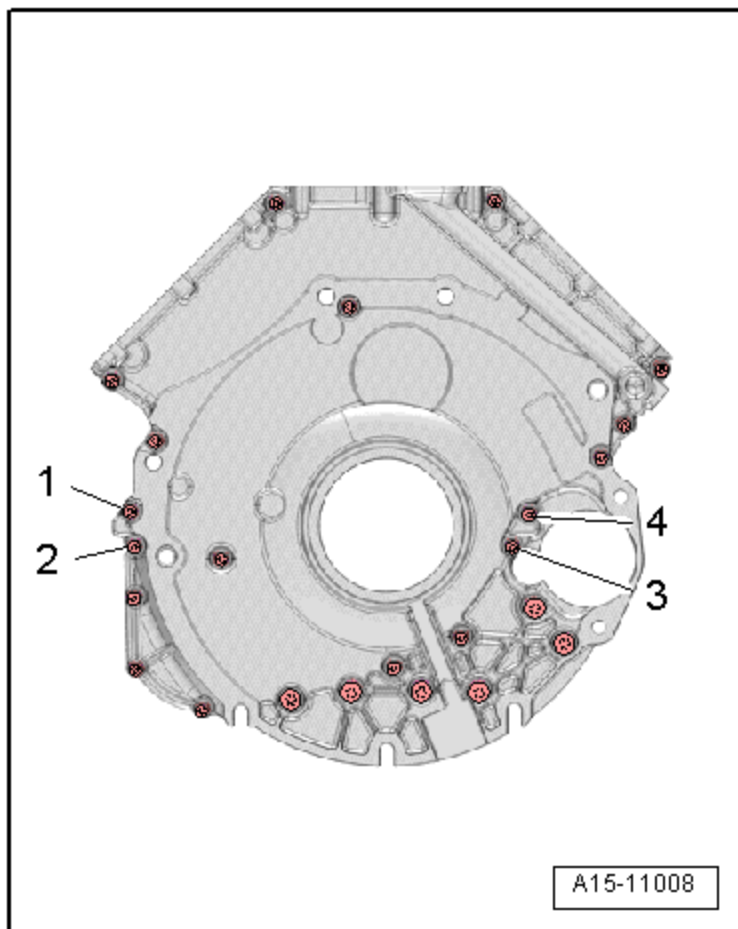

Replace the bolts that have been tightened to additional torque.

Step	Component	Fastener Size	Nm
1		-	Attaching the timing chain guard lower section with the sealant and the sealing pieces to the cylinder block
2	Tighten bolts 1 - 4 in sequence	M26x20	9

## Lower Timing Chain Cover Tightening Specifications (cont'd)

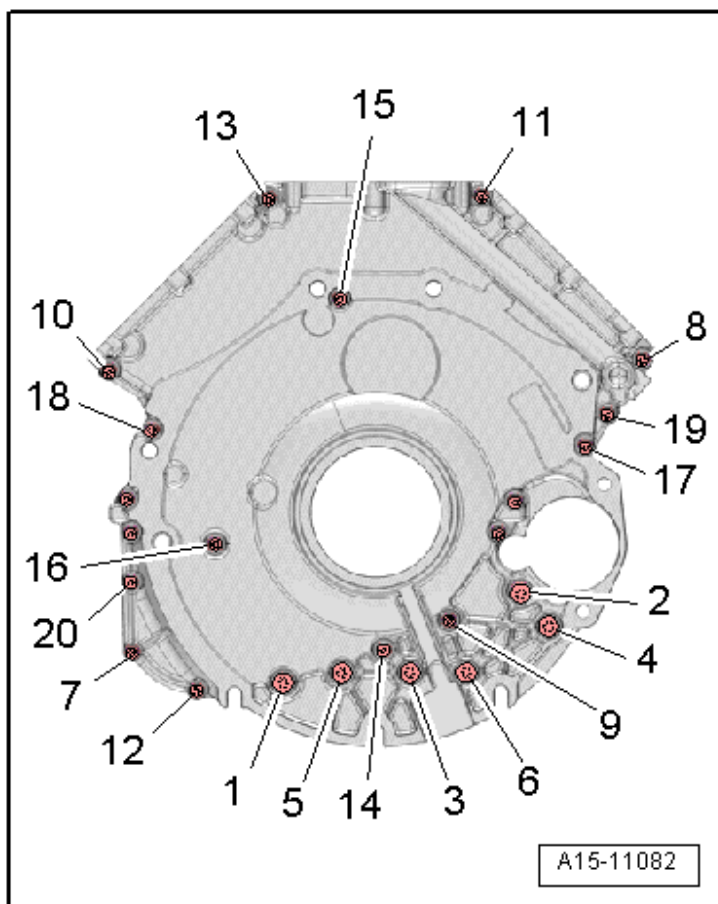

Step	Component	Nm
3	Tighten bolts 1 through 20 in sequence	3
4	Tighten bolts 1 through 20 in sequence	3 Nm - this measurement takes into account the timing chain guard lower section shrinkage
5	Tighten bolts 1 through 20 in sequence	an additional 90° (¼ turn)

## Lower Timing Chain Cover Tightening Specifications (cont'd)

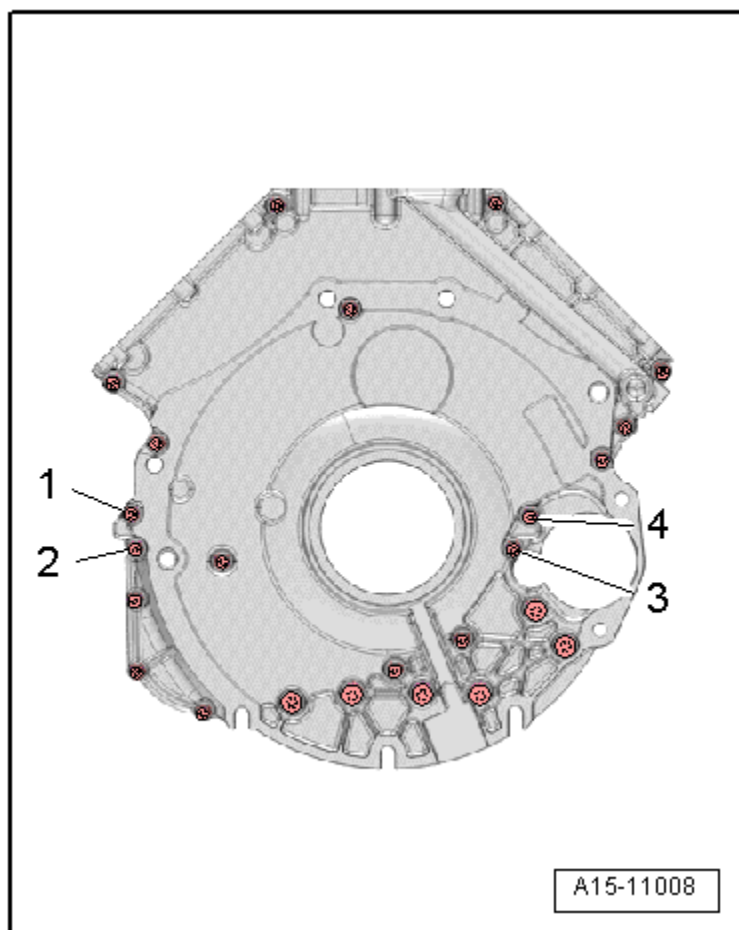

Replace the bolts that have been tightened to additional torque.

Step	Component	Fastener Size	Nm
6	Tighten bolts 1 through 4 in sequence	M26x20	Remove the steel bolts
7	Tighten bolts 1 through 4 in sequence	-	Insert the aluminum bolts and tighten to 3 Nm
8	Tighten bolts 1 through 4 in sequence	-	an additional 90° (¼ turn)

## Cylinder Bank 1 (Right) Bearing Cap Tightening Specifications

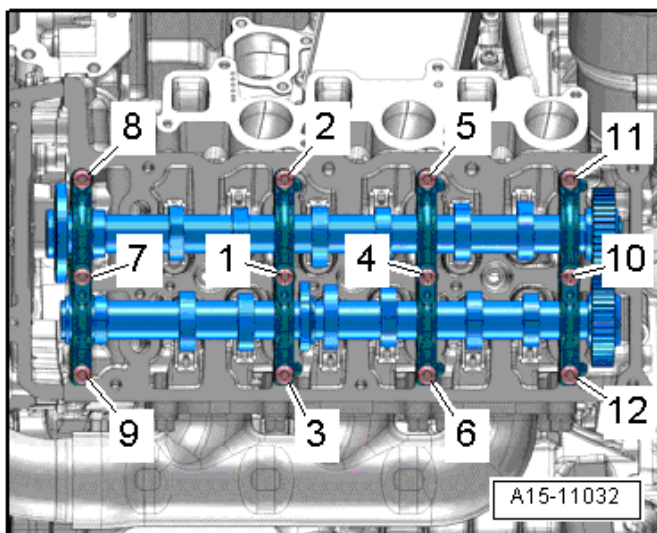

Step	Component	Nm
1	Tighten bolts 1 through 12 in sequence	Hand-tighten
2	Tighten bolts 1 through 12 in sequence	9

## Cylinder Bank 2 (Left) Bearing Cap Tightening Specifications

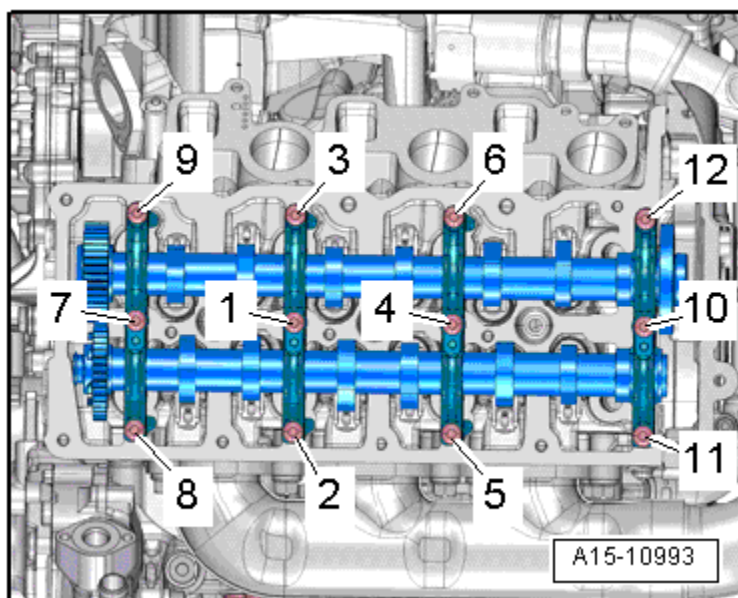

Step	Component	Nm
1	Tighten bolts 1 through 12 in sequence	Hand-tighten
2	Tighten bolts 1 through 12 in sequence	9

# Lubrication – 3.0L CNRB (TDI)

## Fastener Tightening Specifications

Component	Nm
Coolant shut-off valve bolt	9
Engine oil cooler bolt	9
Engine oil cooler mounting plate bolt	9
Engine oil cooler thermostat cover bolt <sup>1)</sup>	3 plus an additional 90° (¼ turn)
Oil baffle bolt <sup>1)</sup>	3 plus an additional 90° (¼ turn)
Oil filter housing bracket	4
Oil filter housing cover	35
Oil filter housing to engine block bolt	9
Oil level thermal sensor nut	9
Oil pan drain plug, lower	30
Oil pan drain plug, upper	25
Oil pressure switch	20
Oil pressure regulation valve bolt	9
Oil pump chain sprocket bolt <sup>1)</sup>	30 plus an additional 45° (⅛ turn)
Oil pump pickup line bolt	9
Oil pump return line bolt	9
Reduced oil pressure switch	20
Transmission dipstick tube bolts	9
Vacuum line bolt	9
Vacuum line to upper oil pan bolt <sup>1)</sup>	3 plus an additional 45° (⅛ turn)

<sup>1)</sup> Replace fastener(s).

## Upper Oil Pan Tightening Specifications

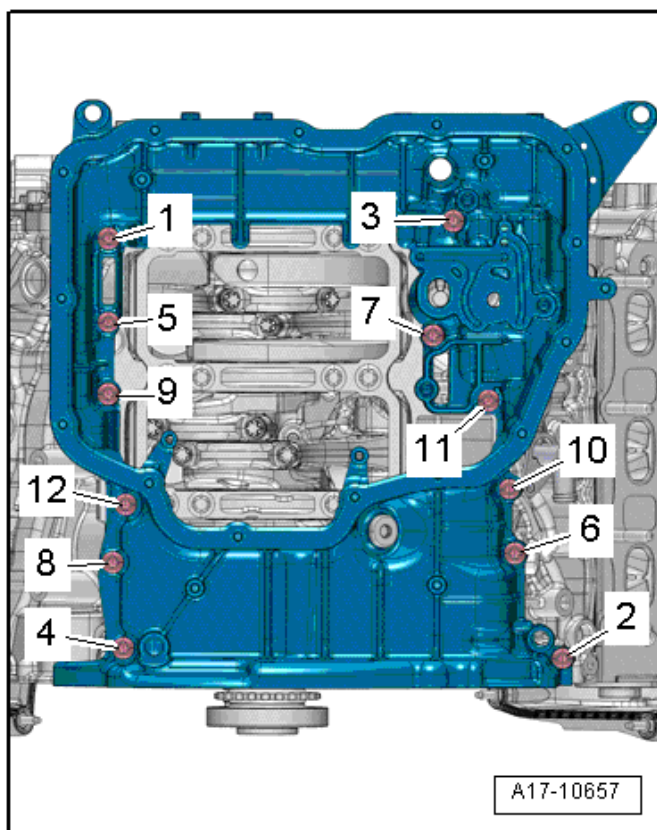

Replace the bolts that have been tightened to additional torque.

Step	Component	Nm
1	Tighten bolts 1 through 12 in a diagonal sequence	2
2	Tighten bolts 1 through 12 in a diagonal sequence	5
3	Tighten bolts 1 through 12 in a diagonal sequence	an additional 90° (¼ turn)



## Oil Pan Tightening Specifications

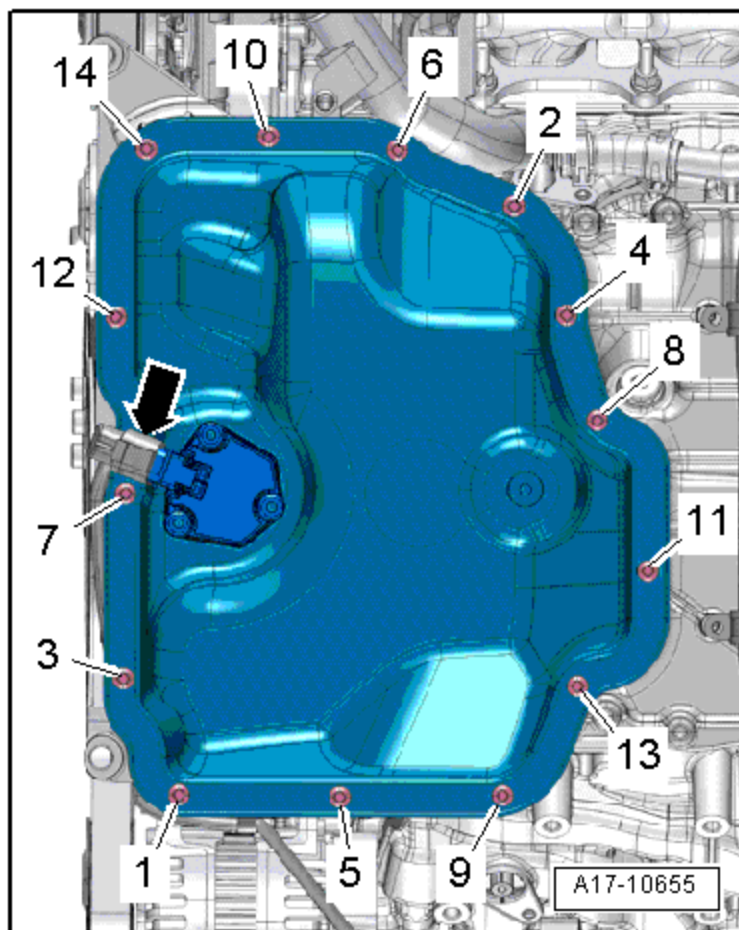

Replace the bolts that have been tightened to additional torque.

Step	Component	Nm
1	Tighten bolts 1 through 14 in a diagonal sequence	2
2	Tighten bolts 1 through 14 in a diagonal sequence	3
3	Tighten bolts 1 through 14 in a diagonal sequence	an additional 90° (¼ turn)

## Oil Pan Tightening Specifications (cont'd)

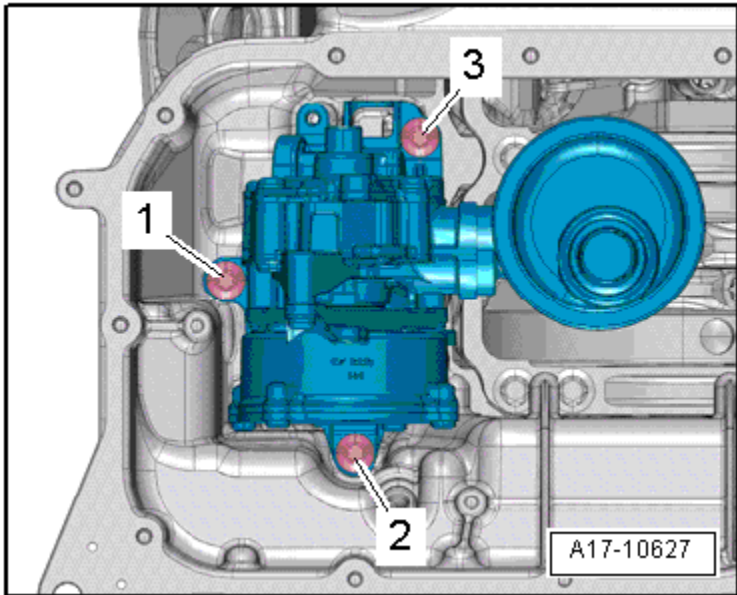

Replace the bolts that have been tightened to additional torque.

Step	Component	Nm
1	Tighten bolts 1 through 3 in a diagonal sequence	Hand-tighten
2	Tighten bolts 1 through 3 in a diagonal sequence	8
3	Tighten bolts 1 through 3 in a diagonal sequence	an additional 90° (¼ turn)

## **Cooling System – 3.0L CNRB (TDI)**

### **Fastener Tightening Specifications**

<b>Component</b>	<b>Nm</b>
Banjo bolts	12
Bleeder screw	9
Coolant hose connections	9
Coolant pipe mounting attaching bolts	9
Coolant pump bolt	9
Coolant pump ribbed belt pulley bolt	23
Coolant shut-off valve bolt	9
Coolant temperature sensor bolt	9
Lower radiator mount bolts	25
Transmission coolant valve bracket-to-transmission bolt	23
Upper radiator mount bolts	5

## **Fuel Supply – 3.0L CNRB (TDI)**

### **Fastener Tightening Specifications**

<b>Component</b>	<b>Nm</b>
Accelerator Pedal Position (APP) sensor-to-body bolt	10
Fuel filter housing-to-body bolt	10
Fuel filter housing cover-to-fuel filter housing bolt	8
Fuel tank lock ring	145
Fuel tank strap-to-body bolt	33

# Turbocharger, G-Charger – 3.0L CNRB (TDI)

## Fastener Tightening Specifications

Component	Nm
Air guide connections	9
Air guide connection to turbocharger bolt	9
Charge air cooler bolt	9
Turbocharger to bracket stud bolts	10

## Turbocharger Tightening Specifications

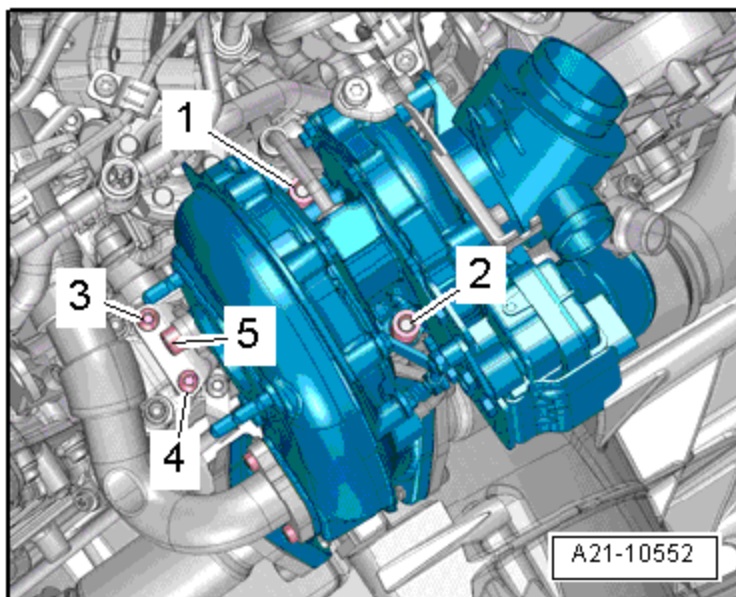

Replace stud bolts and nuts

Step	Component	Nm
1	Tighten 1 through 9 in sequence	10
2	Stud bolts for the nuts 1, 2	
3	Stud bolts for the nuts 1, 2	9
4	Stud bolts for the nuts 1, 2	an additional 90° (¼ turn)
5	3, 4, 5	Hand-tighten
6	3, 4	9
7	5	23

# Exhaust System – 3.0L CNRB (TDI)

## Fastener Tightening Specifications

Component	Nm
Differential pressure sensor nut	3.5
Exhaust Gas Recirculation (EGR) connection to EGR cooler bolt	9
Exhaust Gas Recirculation (EGR) cooler bolt	9
Exhaust Gas Recirculation (EGR) pipe to connection screw type clamp	5
Exhaust Gas Recirculation (EGR) valve 1 bolt	9
Engine temperature control sensor bolt	9
Exhaust gas temperature sensors	45
Exhaust manifold to block nut <sup>1)</sup>	25
Exhaust manifold to pipe bolt <sup>1)</sup>	30 +90°
Muffler suspended mount bolts	25
Nitrogen Oxide (NOx) sensors	25
Oxygen Sensor (O2S)1	50
Particulate sensor	50
Particulate sensor control module nut	3.5
Reducing agent heating element bolt	5
Reducing agent module locking ring	80
Reducing agent tank tray nuts <sup>2)</sup>	10
	20
Tailpipe	60

<sup>1)</sup> Replace fastener(s).

<sup>2)</sup> For bolt tightening clarification, refer to ElsaWeb, *Reducing Agent Tank Overview*, items 4 and 5.

## Exhaust Manifold Tightening Specifications

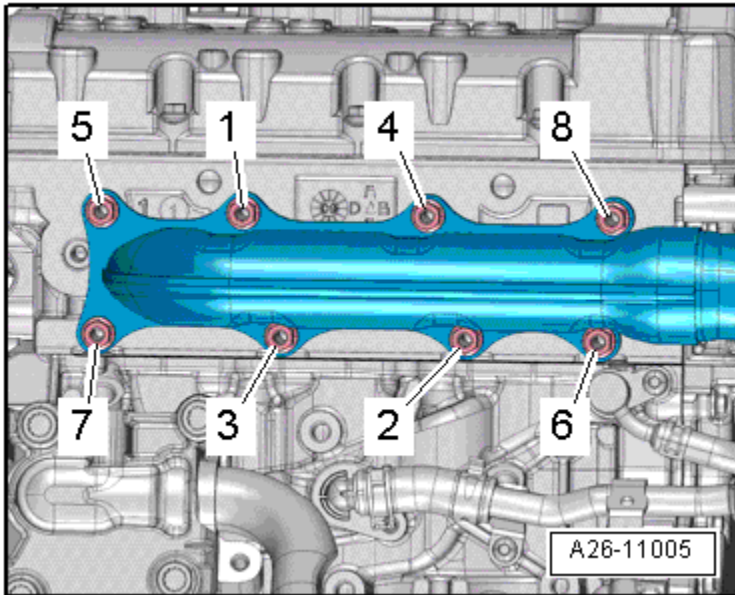

Replace nuts. Coat the nut thread with hot bolt paste. Refer to the Parts Catalog.

Step	Component	Nm
1	Tighten nuts 1 through 9 in sequence	Hand-tighten
2	Tighten nuts 1 through 9 in sequence	15
3	Tighten nuts 1 through 9 in sequence	25

## EGR Pipe at the Intake Manifold Tightening Specifications

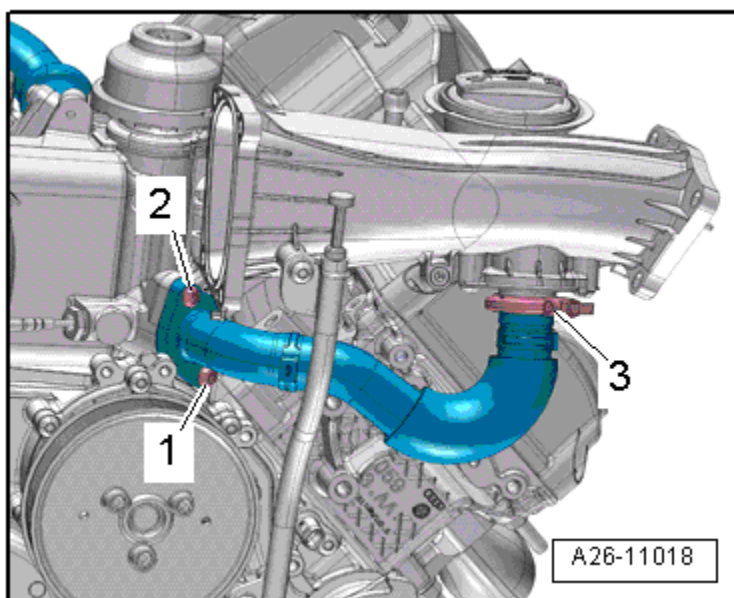

Coat the screw thread with hot bolt past. Refer to the Parts Catalog.

Step	Bolts/screw-type clamps	Nm
1	1, 2	Hand-tighten
2	3	2.5
3	1, 2	9

## EGR Pipe at the Turbocharger Tightening Specifications

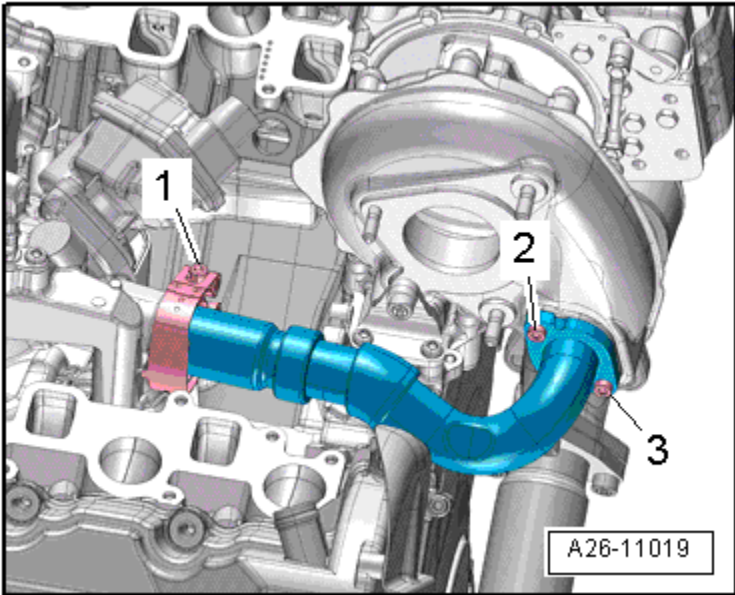

Coat the screw thread with hot bolt past. Refer to the Parts Catalog.

Step	Bolts/screw-type clamps	Nm
1	2, 3	Hand-tighten
2	1	6
3	2, 3	5
4	2, 3	an additional 90° (¼ turn)



# Diesel Fuel Injection – 3.0L CNRB (TDI)

## Fastener Tightening Specifications

Component	Nm
Air filter housing to body bolt	10
Banjo bolt	25
Differential pressure sensor nut	3.5
EGR (Exhaust Gas Recirculation) pipe	9
Engine cover mounting pins	5
Exhaust gas temperature sensors	45
Fuel injector tension clamp bolt	14
Fuel temperature sensor	2
High pressure line	25
High pressure line clamp bolt	9
High pressure fuel rail bolt	22
High pressure pump support adapter nut	70
High pressure pump bolt	22
Intake flap motor bolts	9
Intake manifold air guide bolts	9
Intake manifold air guide bracket bolts	9
Mass airflow (maf) sensor to upper air filter housing	1.5
NOx sensors	45
Oxygen sensor 1	50
Particulate sensor	50
Particulate sensor control module nut <sup>t</sup>	3.5
Tension clamp bracket on camshaft bearing	2.5
Tension clamp bracket on cylinder head	9
Wiring guide and connector bracket bolts	4

## Fuel Pressure Regulator Valve Tightening Specifications

Step	Nm
1	Hand-tighten
2	60
3	Turn back 180°
4	85

## Fuel Pressure Sensor Tightening Specifications

Step	Nm
1	Hand-tighten
2	60
3	Turn back 180°
4	85

## Intake Manifold Tightening Specifications

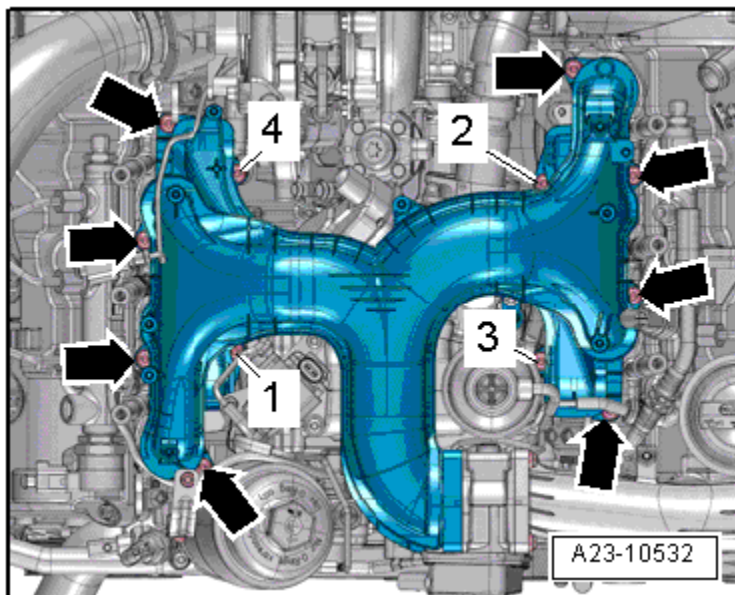

Step	Component	Nm
1	Tighten bolts 1 through 4 in sequence and arrows	Hand-tighten
2	Tighten bolts 1 through 4 in sequence	9
3	Tighten arrows in any sequence	9

## Ignition/Glow Plug System – 3.0L CNRB (TDI)

### Fastener Tightening Specifications

Component	Nm
Camshaft Position Sensor Bolt	9
Engine Speed Sensor Bolt	9
Glow Plug	12

# ENGINE MECHANICAL – 3.0L CGFA

## General, Technical Data

Engine –  
3.0L CGFA

### Engine Number Location

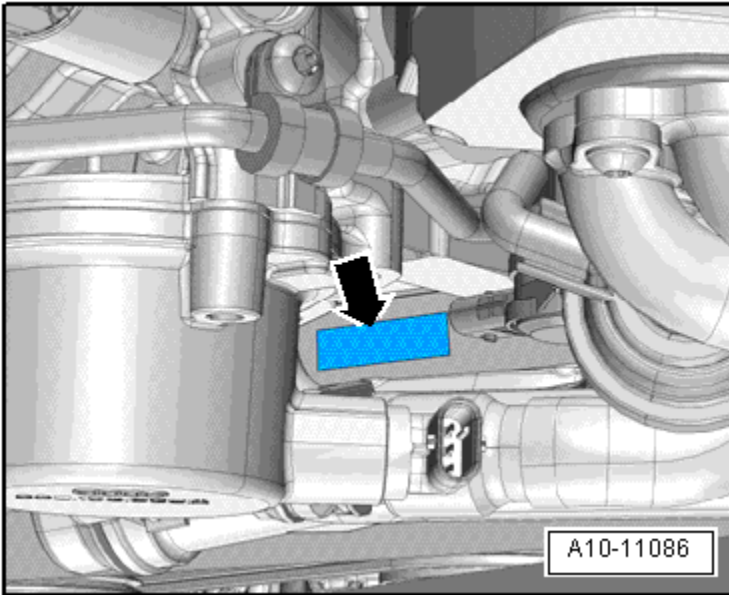

The engine number (engine code and serial number) is located on the top front of the cylinder block, below the right cylinder head (➡). Engine codes beginning with C are four-digit. The first 3 digits of the engine code indicate the displacement and the mechanical structure of the engine. The fourth digit describes the engine output and torque.

## Engine Data

Engine code		CGFA
Displacement	liter	2.968
Output combustion engine	kW at RPM	245 @ 5500
Electro-drive drive motor output	kW	30
Combustion engine tightening specification	Nm at RPM	440 @ 1600
Bore	diameter mm	84.5
Stroke	mm	89.0
Compression ratio		10.5
Research Octane Number (RON)	minimum	98 <sup>1)</sup>
Fuel injection system and ignition system		Motronic MED 17
Emission values in accordance with		ULEV 2 <sup>2)</sup>
Ignition sequence		1-4-3-6-2-5
Exhaust Gas Recirculation (EGR)		no
Turbocharger, Supercharger		Supercharger
Knock control		2 sensors
Oxygen Sensor (O2S) regulation		4 heated oxygen sensors
Charge Air Cooler (CAC)		Yes
Variable valve timing		Intake
Variable intake manifold		No
Secondary Air Injection (AIR) system		Yes
Valve per cylinder		4

<sup>1)</sup> Unleaded RON 95 is permitted but performance is reduced.

<sup>2)</sup> Ultra Low Emissions Vehicle 2.

# Engine Assembly – 3.0L CGFA

## Fastener Tightening Specifications

Component	Fastener size	Nm
Bolts and nuts	M6	10
	M7	15
	M8	25
	M10	40
	M12	60
Engine carrier-to-body bolt <sup>1)</sup>	-	120 plus an additional 180° (½ turn)
Engine mount bracket-to-cylinder block bolt <sup>2)</sup>	-	20
	-	40
Engine mount bracket-to-engine mount nut	-	75
Engine mount-to-engine carrier bolt	-	60
Torque converter-to-electro-drive drive motor bolt	-	60

<sup>1)</sup> Replace fastener(s).

<sup>2)</sup> For bolt tightening clarification, refer to ElsaWeb, *Engine Carrier, Engine Mount and Engine Mount Bracket Overview*, items 4, 8 and 10.

## Electro-Drive Drive Motor to Engine Tightening Specifications

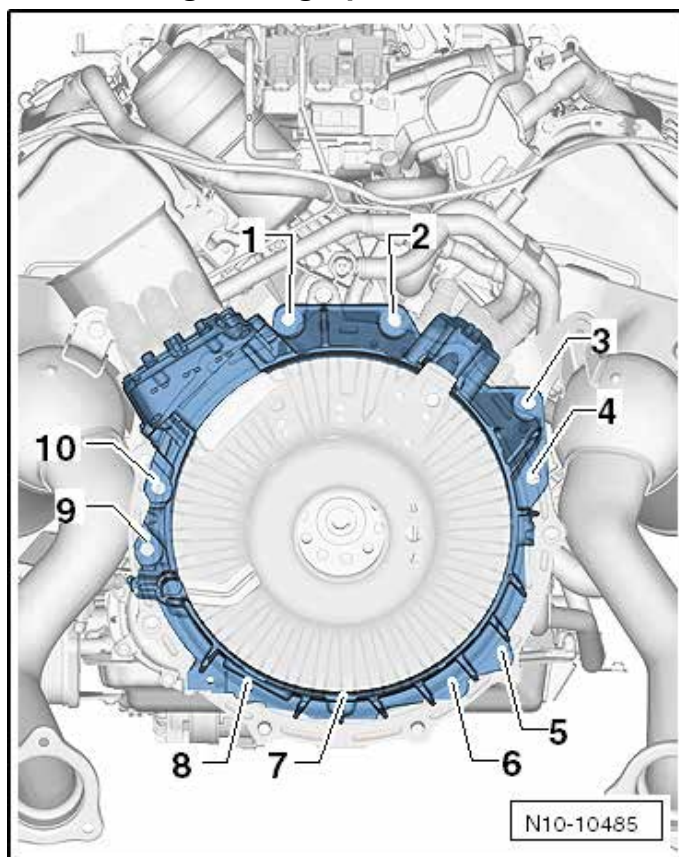

Item	Fastener	Nm
1, 2, 3	M12 x 70	65
4	M10 x 85 with nut	45
5, 6, 7, 8 <sup>1)</sup>	M10 x 60	20 plus an additional 90° (¼ turn)
9	M12 x 70	65
10	M12 x 60 internal multipoint bolt	65

<sup>1)</sup> Replace fastener(s).

## Transmission to Electro-Drive Drive Motor Tightening Specifications

Engine –  
3.0L CGFA

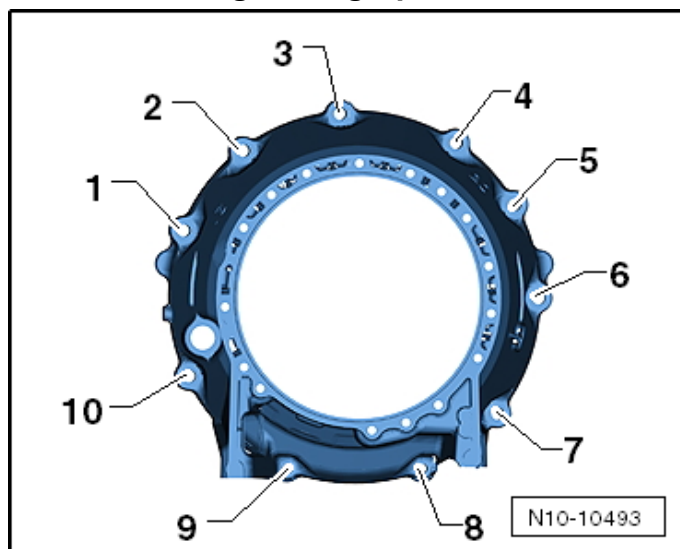

Step	Fastener	Nm
1	Tighten new bolts 1 through 10 in sequence	30 plus an additional 90° (¼ turn)

# Crankshaft, Cylinder Block – 3.0L CGFA

## Allocation of Crankshaft Bearing Shells for Cylinder Block

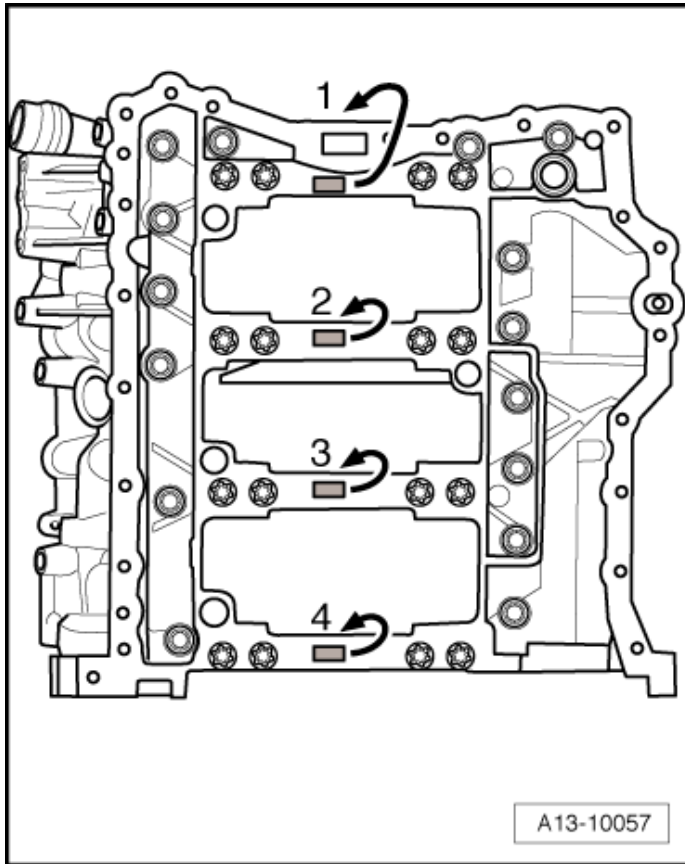

Bearing shells with the correct thickness are allocated to the cylinder block in the factory. Colored dots on the sides of the bearing shells identify the bearing shell thickness. The allocation of the bearing shells to the cylinder block is marked by a letter on the respective bearing on the guide frame.

Letter on guide frame	Color of bearing
R	Red
G	Yellow
B	Blue
S	Black



## Allocation of Crankshaft Bearing Shells for Guide Frame

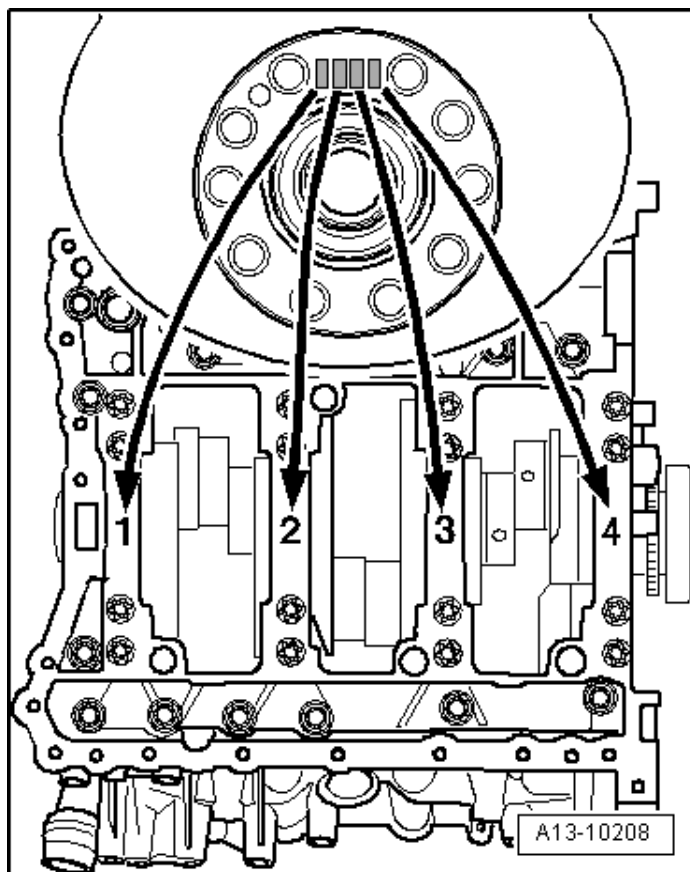

Bearing shells with the correct thickness are allocated to the guide frame at the factory. Colored dots on the sides of the bearing shells identify the bearing shell thickness. The allocation of the bearing shells to the guide frame is marked on the flywheel flange of the crankshaft by a row of letters. The first letter represents bearing 1, the second letter is for bearing 2, etc.

Letter on guide frame	Color of bearing
R	Red
G	Yellow
B	Blue
S	Black

## Fastener Tightening Specifications

Component	Nm
Connecting rod bearing cap-to-connecting rod bolt <sup>1)</sup>	50 plus an additional 90° (¼ turn)
Crankshaft drive plate bolt <sup>1)</sup>	60 plus an additional 90° (¼ turn)
Cylinder block Top Dead Center (TDC) plug	14
Oil spray jet-to-cylinder block bolt	9
Ribbed belt tensioner-to-cylinder block bolt	40
Sealing flange-to-cylinder block bolt <sup>2)</sup>	9
Supercharger ribbed belt idler pulley-to-cylinder block bolt	42
Supercharger ribbed belt tensioner-to-cylinder block bolt	40
Vibration damper-to-crankshaft bolt <sup>1)</sup>	20 plus an additional 90° (¼ turn)

<sup>1)</sup> Replace fastener(s).

<sup>2)</sup> Tighten in a diagonal sequence and in stages.

## Ribbed Belt Sealing Flange Tightening Specification

Engine –  
3.0L CGFA

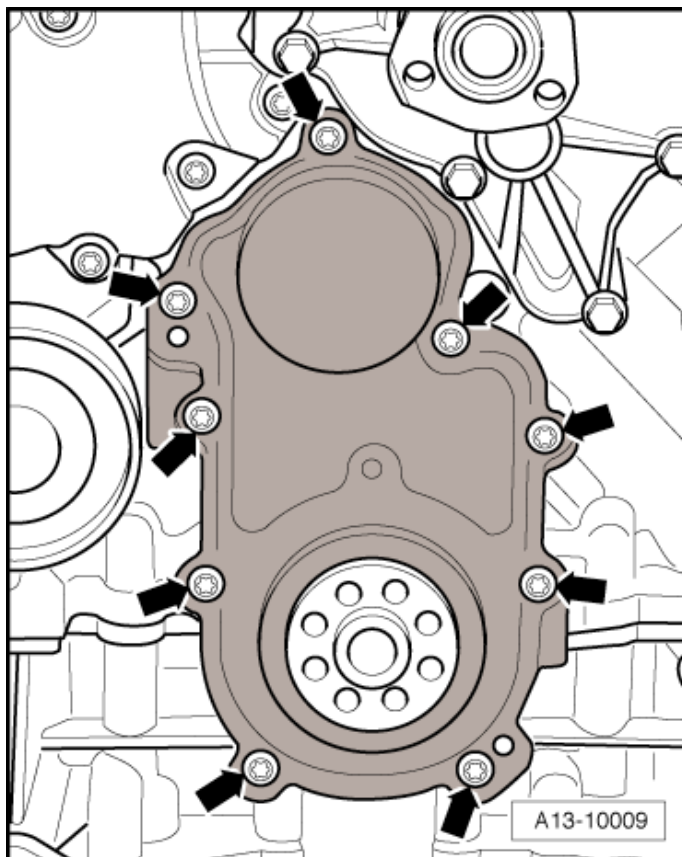

Step	Component	Nm
1	Tighten the bolts (➡) in a diagonal sequence	9

## Guide Frame Tightening Specifications

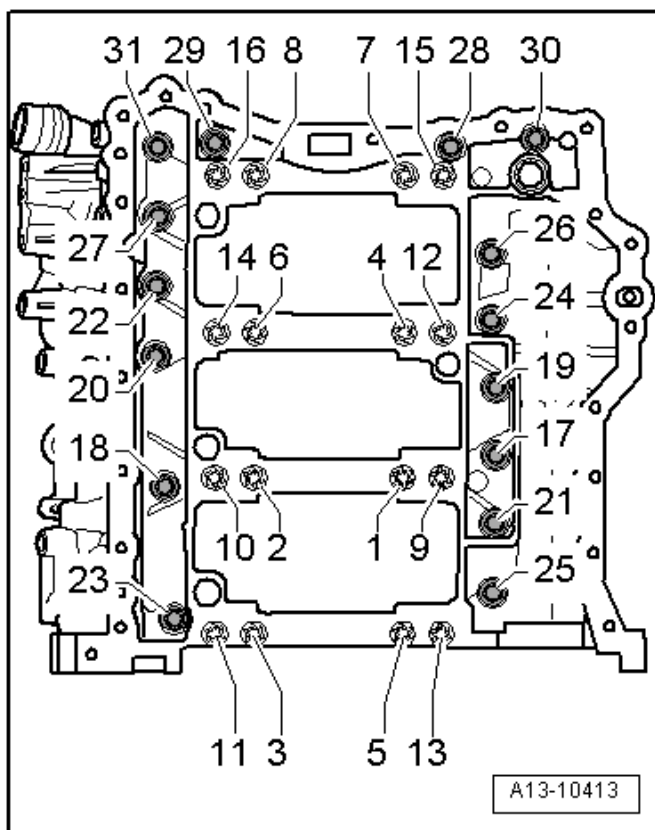

Step	Component	Nm
1	Tighten bolts 1 through 16 in sequence <sup>1)</sup>	50
2	Tighten bolts 1 through 16 in sequence	an additional 90° (¼ turn)
3	Tighten bolts 17 through 31 in sequence (for guide frame sealing surfaces on cylinder block)	23

<sup>1)</sup> Replace fastener(s).

## Crankshaft Dimensions

Honing dimension in mm	Crankshaft bearing pin diameter		Crankshaft connecting rod journal diameter	
Basic dimension	65.000	-0.022	56.000	-0.022
		-0.042		-0.042

## Piston Ring End Gaps

Piston ring dimensions in mm	New	Wear limit
1 <sup>st</sup> compression ring	0.20 to 0.30	0.80
2 <sup>nd</sup> compression ring	0.50 to 0.70	0.80
Oil scraping ring	0.25 to 0.50	– <sup>1)</sup>

<sup>1)</sup> Not determined yet.

## Piston Ring Clearance

Piston ring dimensions in mm	New	Wear limit
1 <sup>st</sup> compression ring	0.04 to 0.08	0.20
2 <sup>nd</sup> compression ring	0.03 to 0.07	0.20
Oil scraping ring	0.02 to 0.06	0.15

## Piston and Cylinder Dimensions

Honing dimension in mm	Piston diameter	Cylinder bore diameter
Basic dimension	84.49 <sup>1)</sup>	84.51

<sup>1)</sup> Dimension without graphite coating (thickness 0.02 mm). The graphite coating wears away.

# Cylinder Head, Valvetrain – 3.0L CGFA

## Fastener Tightening Specifications

Component	Nm
Balance shaft bearing end bracket-to-cylinder block bolt	13
Balance shaft sprocket-to-balance shaft bolt <sup>1)</sup>	15 plus an additional 90° (¼ turn)
Balance weight-to-balance shaft bolt	60
Camshaft adjustment valve-to-cylinder head bolt	5
Camshaft Position (CMP) sensor-to-cylinder head bolt	9
Camshaft timing chain tensioner-to-cylinder head bolt	9
Cylinder block guide rail bolt <sup>1)</sup>	10 plus an additional 90° (¼ turn)
Drive sprocket bearing plate-to-cylinder head bolt <sup>1)</sup>	8 plus an additional 45° (⅙ turn)
Exhaust camshaft sprocket-to-camshaft bolt <sup>1)</sup>	80 plus an additional 90° (¼ turn)
Ignition coil connector strip-to-cylinder head cover bolt	5
Intake camshaft adjuster-to-camshaft bolt <sup>1)</sup>	80 plus an additional 90° (¼ turn)
Left drive sprocket pin-to-drive sprocket bearing plate bolt <sup>1)</sup>	5 plus an additional 60° (⅙ turn)
Oil dipstick guide tube-to-cylinder head bolt	9
Oil pump and balance shaft timing chain tensioner-to-cylinder block bolt <sup>1)</sup>	10 plus an additional 45° (⅙ turn)
Oil pump sprocket-to-oil pump bolt <sup>1)</sup>	30 plus an additional 90° (¼ turn)
Right drive sprocket pin-to-cylinder block bolt <sup>1)</sup>	30 plus an additional 90° (¼ turn)
Wire bracket-to-right timing chain cover nut	9

<sup>1)</sup> Replace fastener(s).

## Compression Checking Specifications

Compression pressure	Bar pressure
New	11.0 to 14.0
Wear limit	10.0
Maximum difference between cylinders	3.0

**Engine –  
3.0L CGFA**

### Valve Dimensions

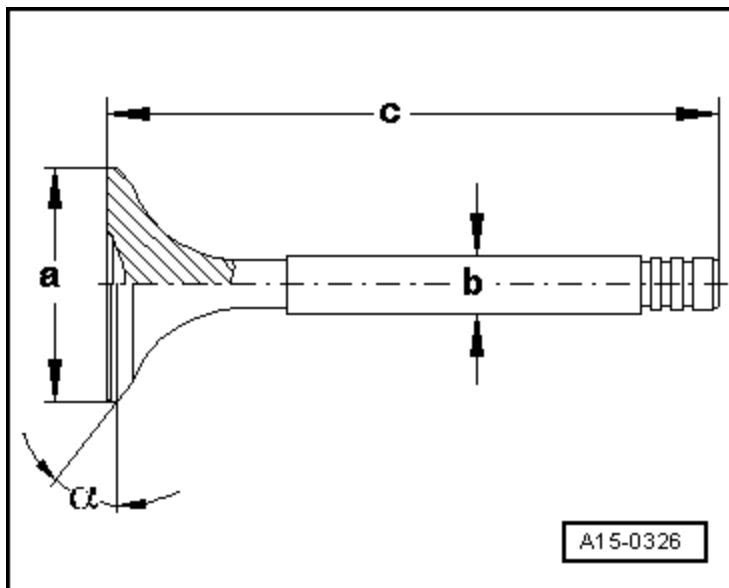

Dimension		Intake valve	Exhaust valve
Diameter a	mm	$33.85 \pm 0.10$	$28.0 \pm 0.1$
Diameter b	mm	$5.98 \pm 0.01$	$5.96 \pm 0.01$
c	mm	$104.0 \pm 0.2$	$101.9 \pm 0.2$
$\alpha$	$\angle^\circ$	45	45

**NOTE:** Intake and exhaust valves must not be refaced by grinding. Only lapping is permitted.

## Left Timing Chain Cover Tightening Specifications

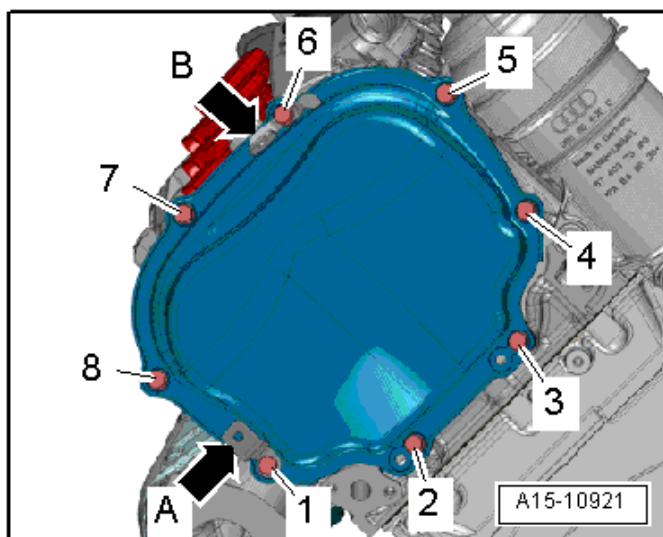

Step	Component	Nm
1	Tighten bolts 1 through 8 in sequence (replace bolts)	5
2	Tighten bolts 1 through 8 in sequence	an additional 90° (¼ turn)

The brackets (A and B) are connected with the left timing chain cover.



## Right Timing Chain Cover Tightening Specifications

Engine –  
3.0L CGFA

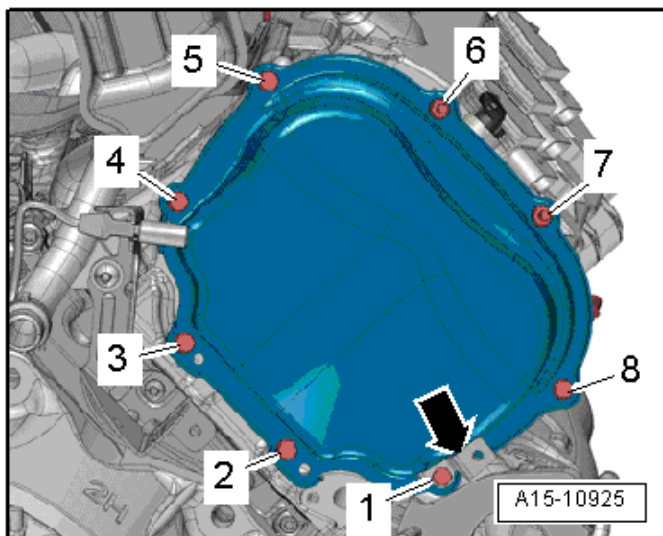

Step	Component	Nm
1	Tighten bolts 1 through 8 in sequence (replace bolts)	5
2	Tighten bolts 1 through 8 in sequence	an additional 90° (¼ turn)

The bracket (➡) is connected with the right timing chain cover.

## Lower Timing Chain Cover Tightening Specifications

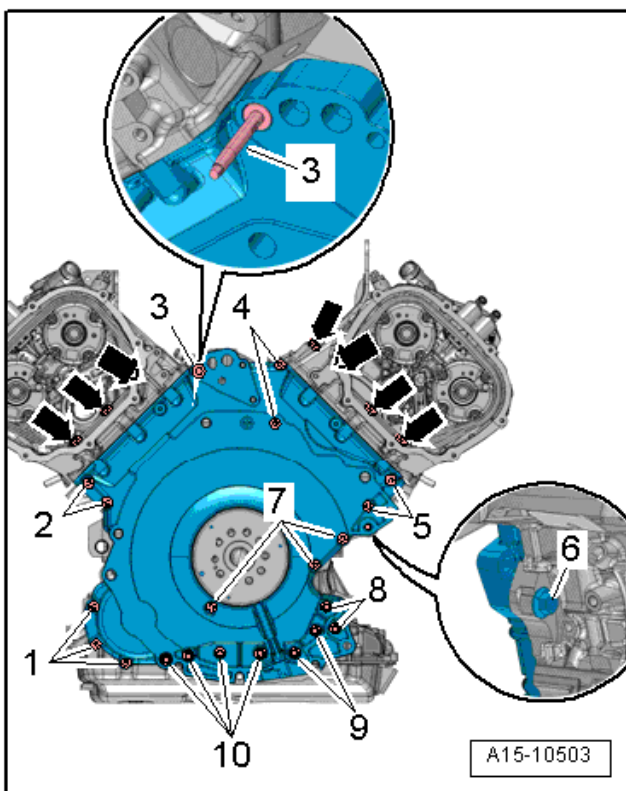

Replace all fasteners except 3.

Step	Component	Nm
1	Tighten the bolts (➡)	3
2	Tighten bolts 1 through 10 in a diagonal sequence	3
3	Tighten bolts 1, 2, 4, 5, 7, and ➡	an additional 90° (¼ turn)
4	Tighten bolts 8, 9 and 10	8
5	Tighten bolts 8, 9 and 10	an additional 90° (¼ turn)
6	Tighten bolt 3	16
7	Tighten bolt 6	20
8	Tighten bolt 6	an additional 90° (¼ turn)

## Cylinder Head Tightening Specifications

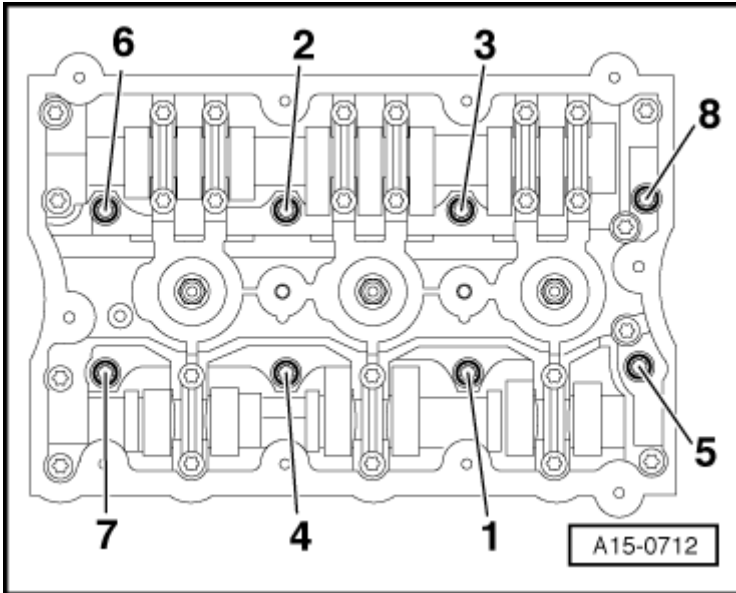

NOTE: The left cylinder head is shown. The right cylinder head is identical.

Step	Component	Nm
1	Tighten bolts 1 through 8 in sequence (replace bolt)	Hand-tighten
2	Tighten bolts 1 through 8 in sequence	40
3	Tighten bolts 1 through 8 in sequence	an additional 90° (¼ turn)
4	Tighten bolts 1 through 8 in sequence	an additional 90° (¼ turn)

## Camshaft Guide Frame Tightening Specifications

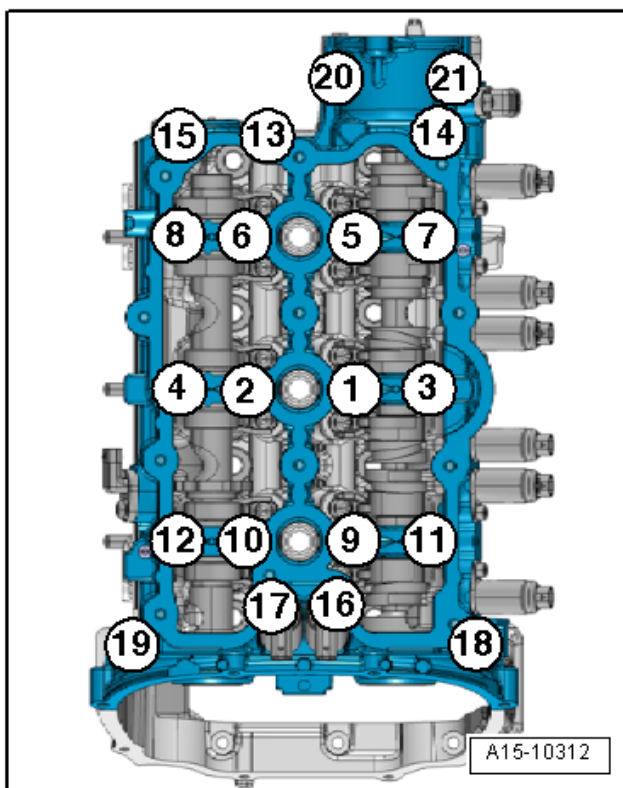

NOTE: The left cylinder head camshaft guide frame is shown.  
The right cylinder head camshaft guide frame is identical.

Step	Component	Nm
1	Tighten bolts 1 through 21 in sequence	Hand-tighten <sup>1)2)</sup>
2	Tighten bolts 1 through 21 in sequence	8
3	Tighten bolts 1 through 21 in sequence	an additional 90° (¼ turn)

<sup>1)</sup> Replace fastener(s).

<sup>2)</sup> The guide frame must be in contact with the entire contact surface of the cylinder head.

## Left Cylinder Head Cover Tightening Specification

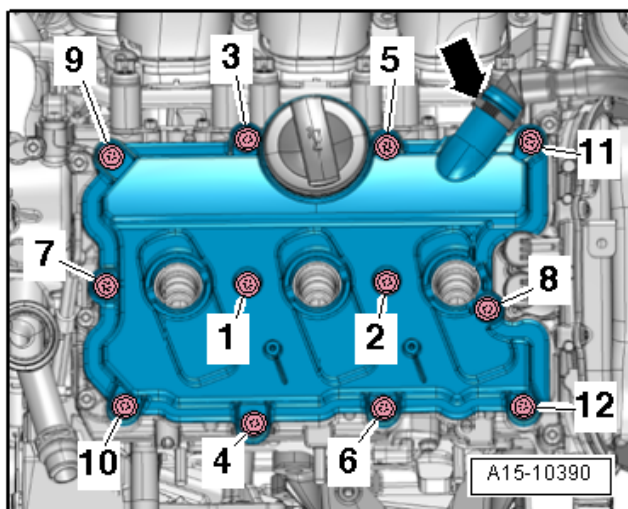

Step	Component	Nm
1	Tighten bolts 1 through 12 in sequence	9

## Right Cylinder Head Cover Tightening Specification

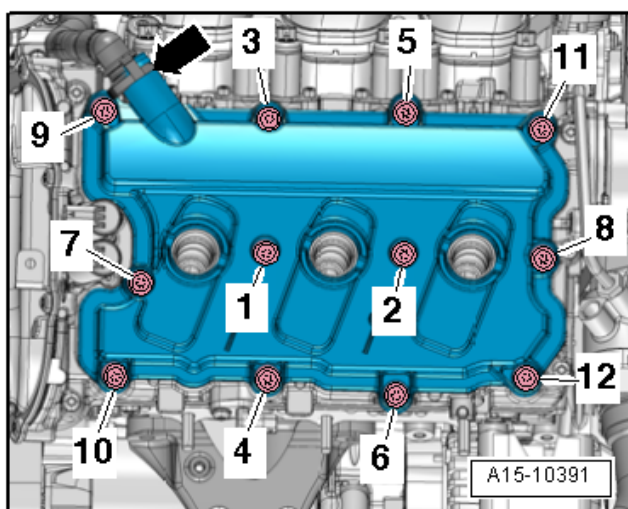

Step	Component	Nm
1	Tighten bolts 1 through 12 in sequence	9

# Engine Lubrication – 3.0L CGFA

## Fastener Tightening Specifications

Component	Nm
Crankcase ventilation hose-to-oil separator cover bolt	3
Engine oil cooler-to-lower oil pan bolt	9
Engine oil cooler-to-upper oil pan bolt <sup>1)</sup>	3 plus an additional 90° (¼ turn)
Lower oil baffle-to-upper oil pan bolt <sup>1)</sup>	3 plus an additional 90° (¼ turn)
Lower oil pan drain plug	30
Lower timing chain cover stud	16
Oil check valve-to-cylinder block	20
Oil filter housing cap	25
Oil filter housing-to-cylinder head bolt	9
Oil filter housing-to-lower timing chain cover bolt	13
Oil filter housing union nut-to-stud	13
Oil level thermal sensor-to-lower oil pan nut	9
Oil pressure switch-to-oil filter housing	20
Oil pump-to-upper oil pan bolt	20
Oil pump driveshaft bracket-to-upper oil pan bolt	9
Oil separator cover-to-cylinder block bolt	9
Reduced oil pressure switch-to-cylinder block	20
Sprocket-to-oil pump driveshaft bolt <sup>1)</sup>	30 plus an additional 90° (¼ turn)
Upper oil baffle-to-upper oil pan bolt	9

<sup>1)</sup> Replace fastener(s).

## Upper Oil Pan Tightening Specifications

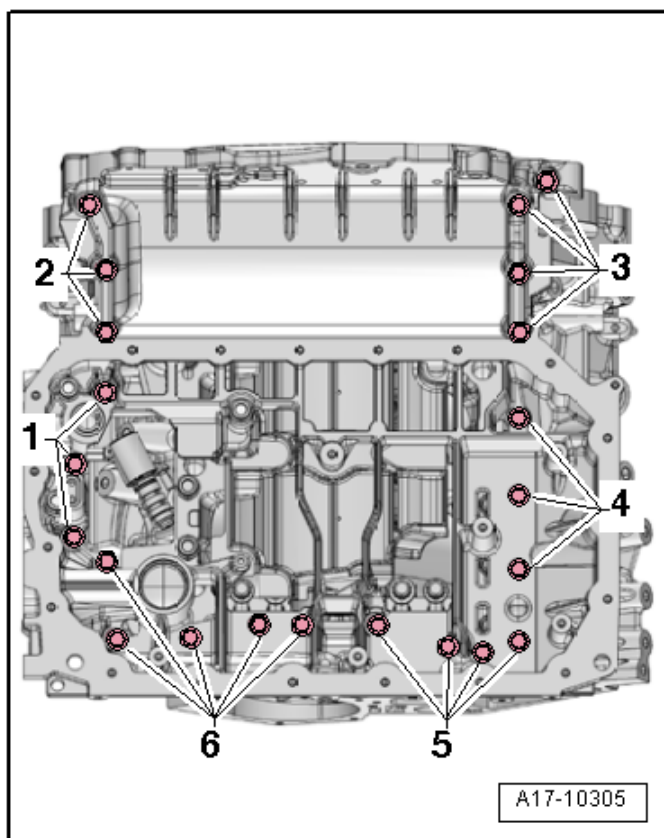

Step	Component	Nm
1	Tighten bolts 1 through 6 in a diagonal sequence	8
2	Tighten bolts 1 through 6 in a diagonal sequence	an additional 90° (¼ turn)

## Oil Pan Tightening Specifications

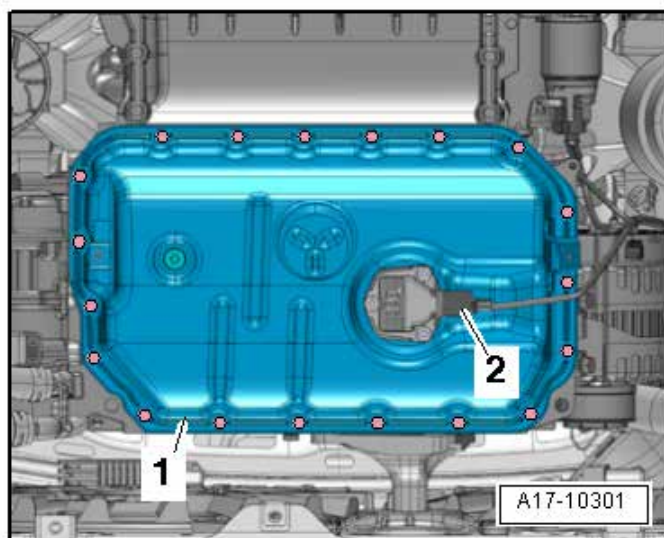

Step	Component	Nm
1	Tighten bolts in a diagonal sequence	5
2	Tighten bolts in a diagonal sequence	an additional 90° (¼ turn)

## Cooling System – 3.0L CGFA

### Fastener Tightening Specifications

Component	Fastener size	Nm
Connecting piece/coolant thermostat-to-cylinder block bolt	-	9
Coolant pipe bolt <sup>1)</sup>	M6	10
	M8	20
Coolant pump-to-cylinder block bolt	-	9
Coolant pump pulley-to-coolant pump bolt	-	20
Cylinder block connecting piece bolt	-	9
Radiator lower mount bolt	-	25
Radiator upper mount bolt	-	5

<sup>1)</sup> For bolt tightening clarification, refer to ElsaWeb, *Coolant System Overviews and Coolant Pipes Overview*.



## **Fuel Supply – 3.0L CGFA**

### **Fastener Tightening Specifications**

<b>Component</b>	<b>Nm</b>
Accelerator Pedal Position (APP) sensor with Accelerator Pedal Position 2 (APP2) sensor-to-body bolt	10
Evaporative Emission (EVAP) canister-to-body bolt	9
Evaporative Emission (EVAP) canister bracket-to-Leak Detection Pump (LDP) bolt	5
Fuel filler tube-to-body bolt	9
Fuel filler tube neck-to-body bolt	5
Fuel tank securing strap-to-body bolt	33
Fuel tank lock ring	145

## **Turbocharger, G-Charger - 3.0L CGFA**

### **Fastener Tightening Specifications**

<b>Component</b>	<b>Nm</b>
Changeover valve bracket-to-supercharger bolt	9
Charge Air Cooler (CAC)-to-supercharger bolt <sup>1)</sup>	10
Charge air pressure sensor-to-supercharger bolt <sup>1)</sup>	10
Control valve control unit-to-lower intake manifold bolt	10
Intake air temperature sensor-to-supercharger bolt <sup>1)</sup>	10
Pin-to-lower intake manifold	17
Supercharger adapter bolt	10
Supercharger breather valve bolt	1.5 to 3.0
Supercharger drive unit bolt <sup>1)</sup>	25
Supercharger insulation plate bolt	5
Supercharger lifting bracket bolt	27
Supercharger-to-pin nut	20
Throttle valve control module-to-supercharger bolt	10

<sup>1)</sup> Replace fastener(s).

# **Exhaust System, Emission Controls – 3.0L CGFA**

## **Fastener Tightening Specifications**

<b>Component</b>	<b>Nm</b>
Clamping sleeve nut	35
Exhaust manifold heat shield-to-cylinder head/exhaust manifold bolt	10
Front exhaust pipe with catalytic converter-to-exhaust manifold nut <sup>1)</sup>	23
Front exhaust pipe with catalytic converter support-to-catalytic converter bolt	23
Front muffler-to-front exhaust pipe with catalytic converter nut <sup>1)</sup>	23
Front muffler support-to-muffler bolt	23
Oxygen Sensor (O2S)	55
Secondary Air Injection (AIR) combination valve-to-cylinder head bolt	9
Secondary Air Injection (AIR) pipe-to-Secondary Air Injection (AIR) combination valve bolt	5
Secondary Air Injection (AIR) pump motor bracket nut	9
Suspended mount-to-underbody bolt	23
Tailpipe clamp bolt	60

<sup>1)</sup> Replace fastener(s).

## Left Exhaust Manifold Tightening Specifications

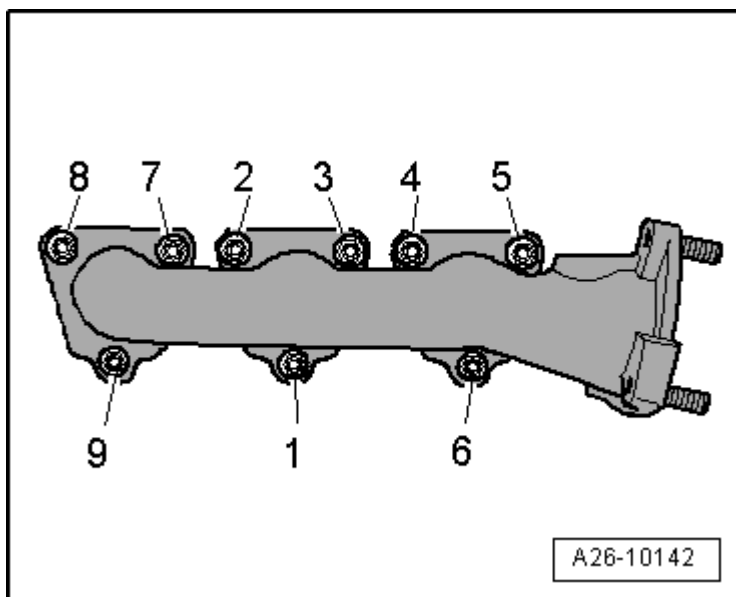

Engine –  
3.0L CGFA

Step	Component	Nm
1	Tighten bolts 1 through 9 in sequence	Hand-tighten
2	Tighten bolts 1 through 9 in sequence	15
3	Tighten bolts 1 through 9 in sequence	25

## Right Exhaust Manifold Tightening Specifications

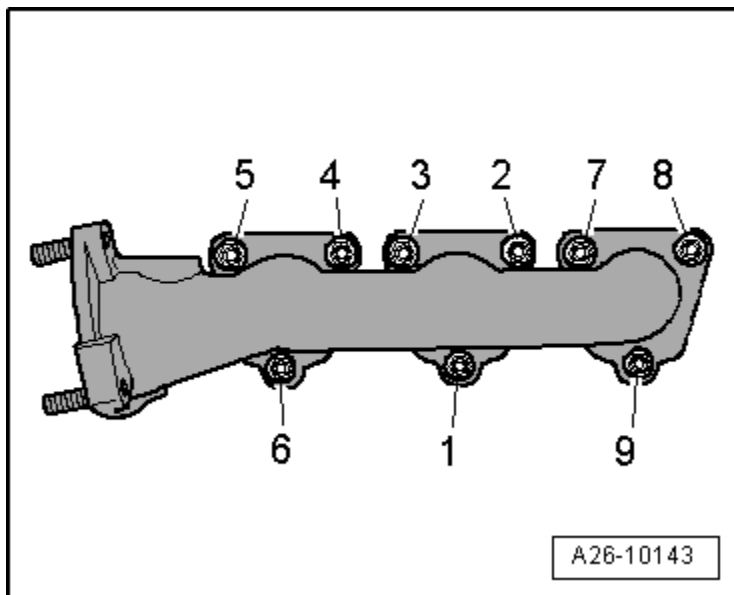

Step	Component	Nm
1	Tighten bolts 1 through 9 in sequence	Hand-tighten
2	Tighten bolts 1 through 9 in sequence	15
3	Tighten bolts 1 through 9 in sequence	25

# Multiport Fuel Injection – 3.0L CGFA

## Technical Data

<b>Engine code</b>	<b>CGFA</b>	
<b>Idle check</b>		
Engine idle speed <sup>1)</sup>	600 to 800 RPM	
<b>Engine Control Module (ECM) (J623)</b>		
System designation	Motronic MED 17.1	
Part number	Refer to the Electronic Parts Catalog (ETKA)	
Engine Speed (RPM) limitation	Approximately 6200 RPM	
<b>Fuel pressure</b>		
Low pressure	bar	Approximately 6.0
High pressure	bar	18 to 120

<sup>1)</sup> Idle speed is not adjustable.

## Fastener Tightening Specifications

<b>Component</b>	<b>Nm</b>
Fuel pressure sensor-to-fuel rail	22
Fuel rail connecting piece	40
Fuel rail retainer bolt/nut <sup>1)</sup>	2.5
	9
Fuel supply line clamp nut	9
High pressure line bracket bolt	9
High pressure line clamp-to-high pressure line bracket bolt	9
High pressure line union nut-to-threaded connection (fuel rail)	27
High pressure line union nut-to-connecting piece (high pressure pump)	25
High pressure pump connecting piece	27
High pressure pump housing stud bolt <sup>2)</sup>	9
High pressure pump protective plate stud bolt/nut	9
Intake manifold runner position sensor-to-intake manifold runner control vacuum actuator bolt	2.5
Low fuel pressure sensor-to-fuel supply line	15
Lower air filter housing-to-body bolt	9

<sup>1)</sup> For bolt tightening clarification, refer to ElsaWeb, *Lower Intake Manifold with Fuel Rail Overview*, items 10, 11 and 12.

<sup>2)</sup> Alternating, all the way by hand

## Lower Intake Manifold Tightening Specification

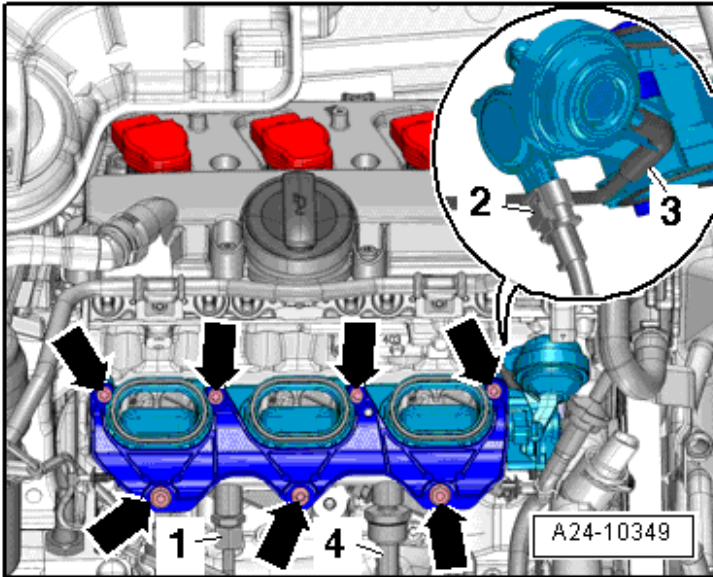

Step	Component	Nm
1	Tighten bolt and nuts (➡) diagonally in stages	10

## Ignition/Glow Plug System – 3.0L CGFA

### Technical Data

<b>Engine code</b>	<b>CGFA</b>
Ignition sequence	1-4-3-6-2-5
<b>Spark plugs</b>	
VW/Audi	101 905 611 G
Electrode gap	Maximum 1.1 mm
Tightening specifications <sup>1)</sup>	30 Nm

<sup>1)</sup> Remove and install spark plugs using the spark plug removal tool (3122 B).

### Fastener Tightening Specifications

Component	Nm
Camshaft Adjustment Valve Bolt	5
Camshaft Position Sensor Bolt	9
Engine Speed Sensor Bolt	9
Front Final Drive Bolt	90
Ignition Coil Wire Harness Clamp Bolt	5
Knock Sensor Bolt	20
Spark Plug	30

# ENGINE MECHANICAL – 3.6L CGRA

## General, Technical Data

### Engine Number Location

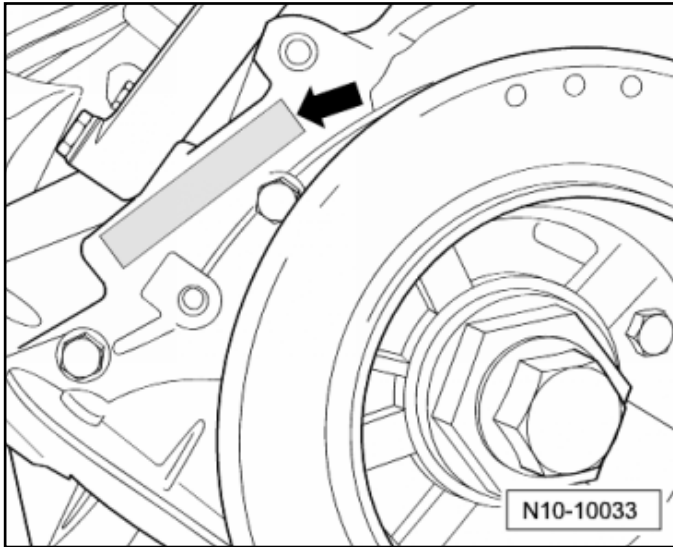

The engine number (engine code and serial number) is located next to the vibration damper (➡) on the cylinder block. Engine codes beginning with C are four-digit. The first 3 digits of the engine code indicate the displacement and the mechanical structure of the engine. The fourth digit describes the engine output and torque.

Engine –  
3.6L CGRA

## Engine Data

Code letters		CGRA
Manufactured		from CW 15.2010
Displacement	cm <sup>3</sup>	3597
Output	kW at RPM	206 @ 6200
Torque	Nm at RPM	360 @ 2900 to 4000
Bore	diameter mm	89.0
Stroke	mm	96.4
Cylinder angle		10.6°
Compression ratio		11.4
Valves per cylinder		4
Research Octane Number (RON)		98 unleaded <sup>1)</sup>
Fuel injection, ignition		Motronic MED 17
Knock control		2 knock sensors
Oxygen Sensor (O2S) regulation		Yes, 4 Heated Oxygen Sensors (HO2S)
Catalytic converter		Yes
Leak detection system		Yes
Exhaust Gas Recirculation (EGR)		No
Thermo management		Yes

<sup>1)</sup> Unleaded RON 95 is permitted but performance is reduced.

## Engine Assembly – 3.6L CGRA

### Fastener Tightening Specifications

Component	Fastener size	Nm
Bolts and nuts	M6	10
	M7	15
	M8	25
	M10	40
	M12	60
Engine carrier-to-chassis bolt	-	100 plus an additional 180° (½ turn)
Engine mount bracket-to-engine mount nut	-	75
Engine mount-to-engine carrier bolt	-	60
Left engine mount bracket-to-cylinder block bolt	-	25
Right engine mount bracket-to-cylinder block bolt	-	40



# Crankshaft, Cylinder Block – 3.6L CGRA

## Allocation of Crankshaft Bearing Shells for Cylinder Block

The main bearing shells are allocated to the cylinder block and crankshaft with the correct thickness at the factory.

Colored dots identify the bearing thicknesses.

Allocate the bearing shells if the cylinder block or the crankshaft are being replaced.

The bearing shell for the cylinder block (upper bearing shell) is always marked in yellow.

Using the letters on the cylinder block and crankshaft, determine the correct colored identification for the bearing shell in the bearing cover (lower bearing shell).

The first letter is for bearing cap 1, the second for bearing cap 2, etc.

Engine –  
3.6L CGRA

## Cylinder Block Identification

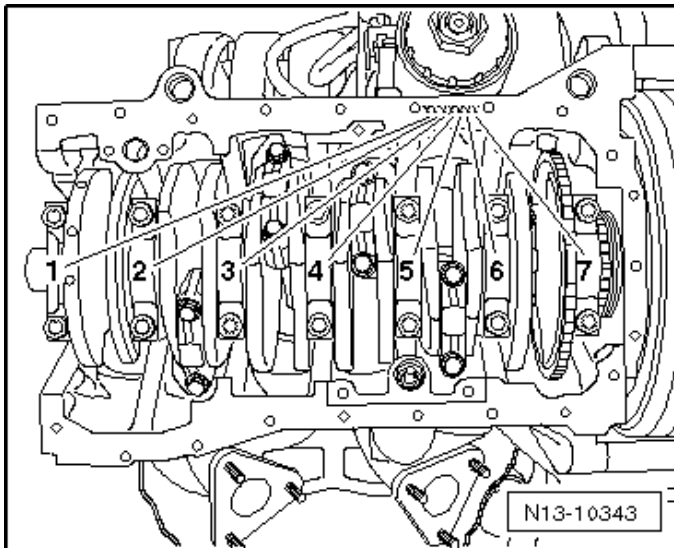

The letters are located on the oil pan sealing surface.

## Crankshaft Identification

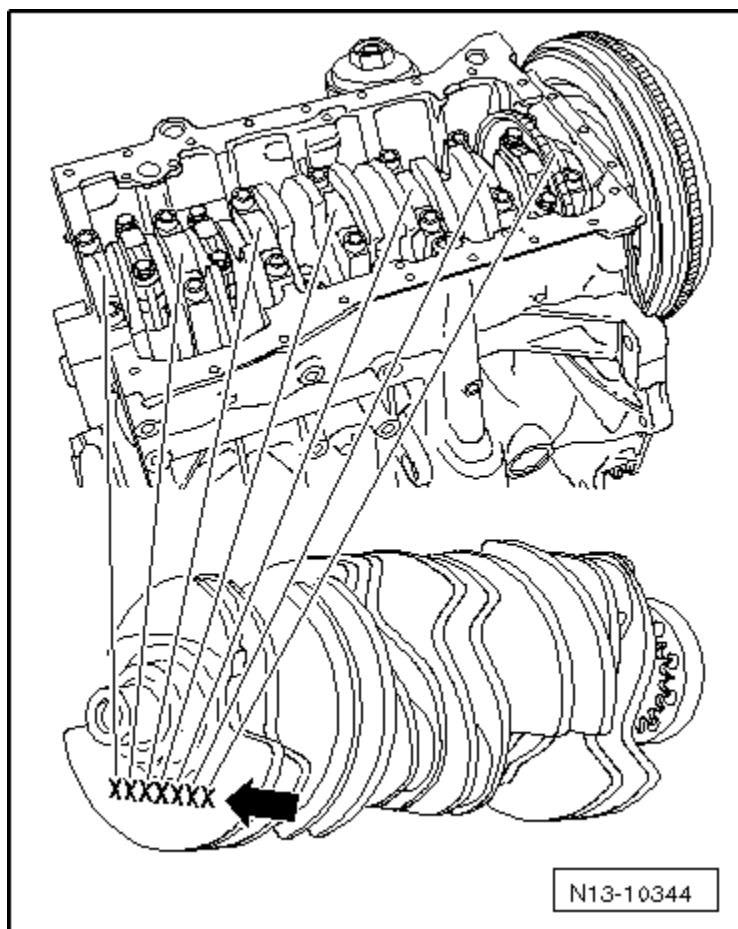

The letters are located on the outer crankshaft counterweight for cylinder 1.

Note the letters and then match them to the color identification in the table.

Letter on the cylinder block	Letter on the crankshaft counterweight	Bearing shell color identification for the bearing cap	Bearing shell color identification for the cylinder block
A, B, C, D, E	R	Red	Yellow
A, B, C, D, E	G	Red	Yellow
A, B, C, D, E	B	Yellow	Yellow
A, B, C, D, E	V	Blue	Yellow
G, H, I	R	Red	Yellow
G, H, I	G	Red	Yellow
G, H, I	B	Yellow	Yellow
G, H, I	V	Blue	Yellow
K, L, M	R	Red	Yellow
K, L, M	G	Yellow	Yellow
K, L, M	B	Blue	Yellow
K, L, M	V	Purple	Yellow

**Example:**

<b>Bearing Cap</b>	<b>1</b>	<b>2</b>	<b>3</b>	<b>4</b>	<b>5</b>	<b>6</b>	<b>7</b>
Letter on the cylinder block	G	H	H	H	G	E	G
Letter on the crankshaft counterweight	G	B	B	V	B	B	G
Bearing shell color identification for the bearing cap	Red	Yellow	Yellow	Blue	Yellow	Yellow	Red

## Fastener Tightening Specifications

Component	Nm
Camshaft actuator-to-camshaft bolt <sup>1) 3)</sup>	60 plus an additional 90° (¼ turn)
Camshaft Position (CMP) sensor-to-cover bolt	8
Chain tensioner with tensioning rail-to-cylinder block bolt	10
Connecting rod bearing cap bolt <sup>1)</sup>	40 plus an additional 90° (¼ turn)
Crankshaft bearing cap-to-cylinder block bolt <sup>1)</sup>	30 plus an additional 180° (½ turn)
Crankshaft drive plate bolt <sup>1)</sup>	60 plus an additional 90° (¼ turn)
Crankshaft Position (CKP) sensor wheel screw <sup>1)</sup>	10 plus an additional 90° (¼ turn)
Cylinder block chain tensioner	50
Cylinder block guide rail locating pin (without collar)	10
Cylinder block guide rail pivot pin	10
Cylinder head cover bolt <sup>5)</sup>	8
Cylinder head guide rail bolt	23
Engine speed sensor-to-cylinder block bolt	10
Knock Sensor (KS)-to-cylinder block bolt <sup>4)</sup>	20
Oil dipstick guide tube-to-intake manifold bolt	6
Oil filter housing/engine mount bracket-to-cylinder block bolt	23
Oil intake pipe-to-cylinder block bolt <sup>2)</sup>	8
Oil level thermal sensor-to-oil pan bolt	12
Oil pan drain plug <sup>1)</sup>	30
Oil pan-to-cylinder block bolt	10
Oil pressure pipe-to-cylinder block bolt <sup>2)</sup>	8
Oil pump sprocket bolt <sup>1)</sup>	60 plus an additional 90° (¼ turn)
Oil pump-to-cylinder block bolt <sup>2)</sup>	8
Sealing flange-to-cylinder block bolt	10
Sealing flange-to-timing chain cover bolt	23
Tensioning rail-to-cylinder block pivot pin	10
Vibration damper-to-crankshaft bolt	60 plus an additional 180° (½ turn)

<sup>1)</sup> Replace fastener(s).

<sup>2)</sup> Install using liquid locking compound (D 000 600 A2).

<sup>3)</sup> The contact surfaces of the adjuster wheel and bolt head must be dry when installing.

<sup>4)</sup> Tightening specification affects the function of the Knock Sensor (KS).

<sup>5)</sup> Tighten in a diagonal sequence and in stages.

## Sealing Flange Tightening Specifications

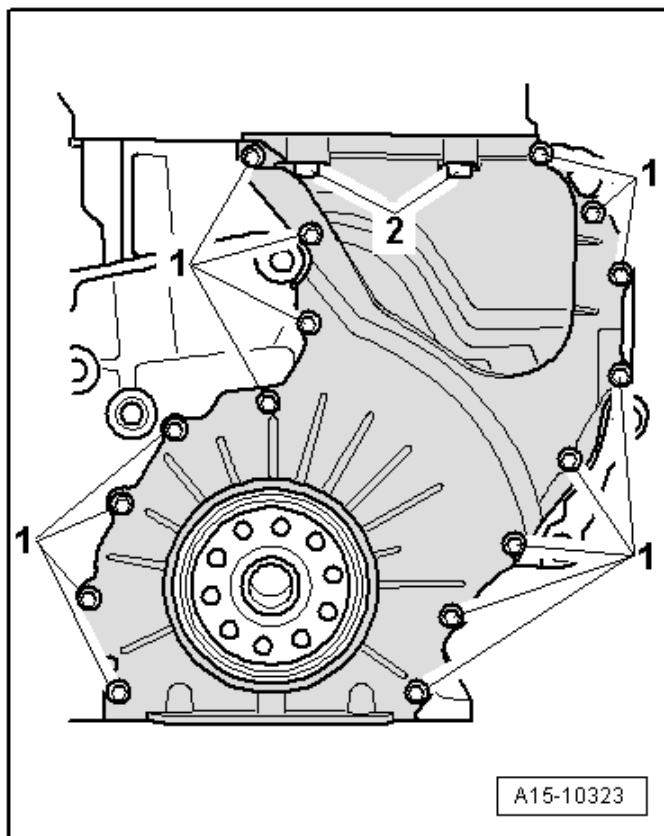

Engine –  
3.6L CGRA

Step	Component	Nm
1	Tighten bolts 1 in a diagonal sequence	5
2	Tighten bolts 2	23
3	Tighten bolts 1 in a diagonal sequence	10

## Accessory Bracket Tightening Specifications

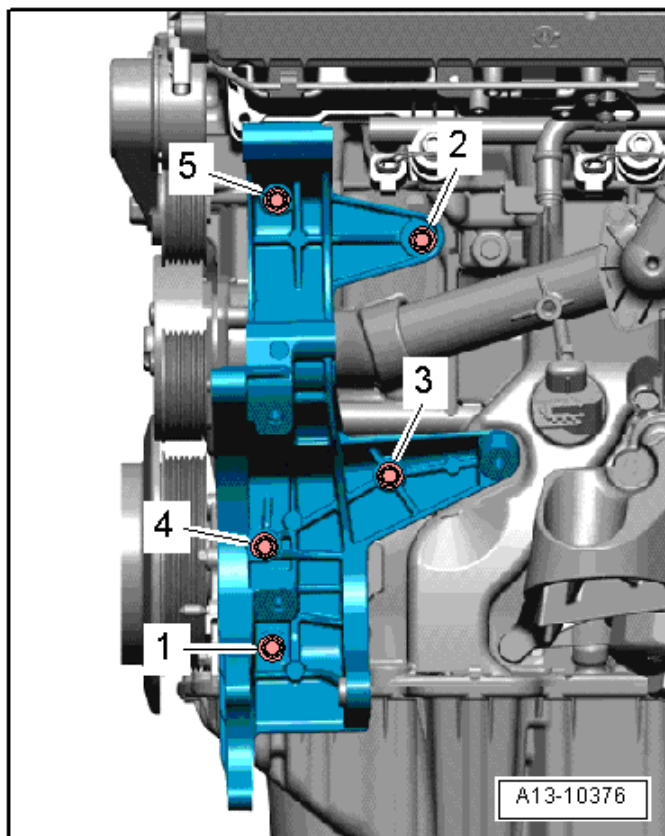

Step	Component	Nm
1	Tighten bolts 1 through 5 in sequence	Hand-tighten
2	Tighten bolts 1 through 5 in sequence	25

## Crankshaft Dimensions

Crankshaft bearing	Crankshaft connecting rod bearing
59.958 to 59.978 mm	53.958 to 53.978 mm

## Piston Ring End Gaps

Piston ring dimensions in mm	Gap	
	New	Wear limit
Compression ring	0.20 to 0.40	1.0
Tapered ring	0.20 to 0.40	1.0
Oil scraping ring	0.25 to 0.50	1.0

## Piston Ring Clearance

Piston ring dimensions in mm	Ring to groove clearance	
	New	Wear limit
Compression ring	0.04 to 0.09	0.15
Tapered ring	0.03 to 0.06	0.15
Oil scraping ring	0.02 to 0.06	0.15

## Piston and Cylinder Dimensions

Honing dimension in mm	Piston diameter	Cylinder bore diameter
Basic dimension	88.945	89.010

# Cylinder Head, Valvetrain – 3.6L CGRA

## Fastener Tightening Specifications

Component	Nm
Bracket-to-cover bolt	8
Camshaft adjuster bolt <sup>1)</sup>	60 plus an additional 90° (¼ turn)
Camshaft adjuster valve-to-control housing bolt	3.8
Chain tensioner-to-cylinder block	50
<b>Control housing-to-cylinder head bolt <sup>2)</sup></b>	
Hex socket head bolt (TORX®)	8 plus an additional 90° (¼ turn)
Internal multi-point bolt (XZN)	8 plus an additional 180° (½ turn)
Cylinder block lifting eye bolt	23
Cylinder head cover bolt	8
Cylinder head guide rail bolt	23
Intake manifold support-to-cylinder block bolt	23
Spark plug	20
Upper intake manifold-to-lower intake manifold bolt	10
Vacuum pump cover bolt	8
Water connection-to-cylinder head bolt <sup>3)</sup>	10
Water connection-to-cylinder head bolt <sup>2)3)</sup>	23

<sup>1)</sup> Replace fastener(s).

<sup>2)</sup> Install using liquid locking fluid (D 000 600 A2).

<sup>3)</sup> For bolt tightening clarification, refer to ElsaWeb, *Cylinder Head Overview*, items 8 and 19.

## Compression Checking Specifications

Compression pressure	Bar pressure
New	11.0 to 13.0
Wear limit bar positive pressure	8.0
Maximum difference between cylinders	3.0



## Valve Dimensions

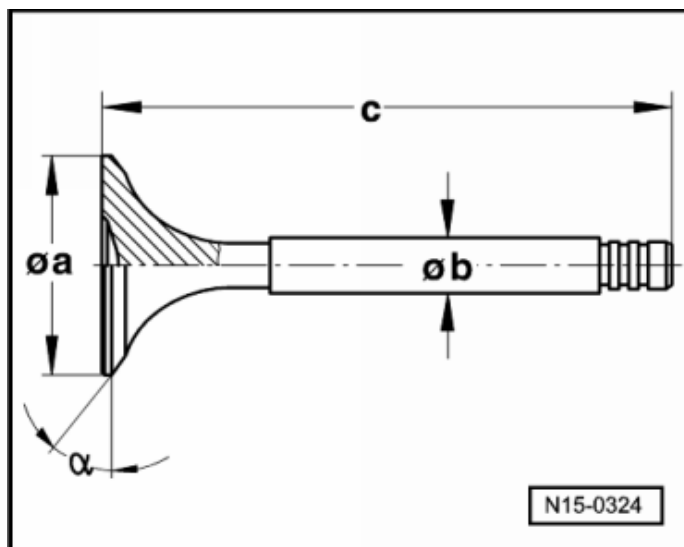

Engine –  
3.6L CGRA

### Dimensions for Intake Valves

Dimension		Short valve	Long valve
Diameter a	mm	33.20	33.20
Diameter b	mm	5.98	5.98
c	mm	102.46	136.36
$\alpha$	$\angle^\circ$	44° 40'	44° 40'

### Dimensions for Exhaust Valves

Dimension		Short valve	Long valve
Diameter a	mm	30.20	30.20
Diameter b	mm	5.97	5.97
c	mm	102.20	136.20
$\alpha$	$\angle^\circ$	44° 40'	44° 40'

NOTE: Intake and exhaust valves must not be refaced by grinding. Only lapping is permitted.

## Cylinder Head Tightening Specifications

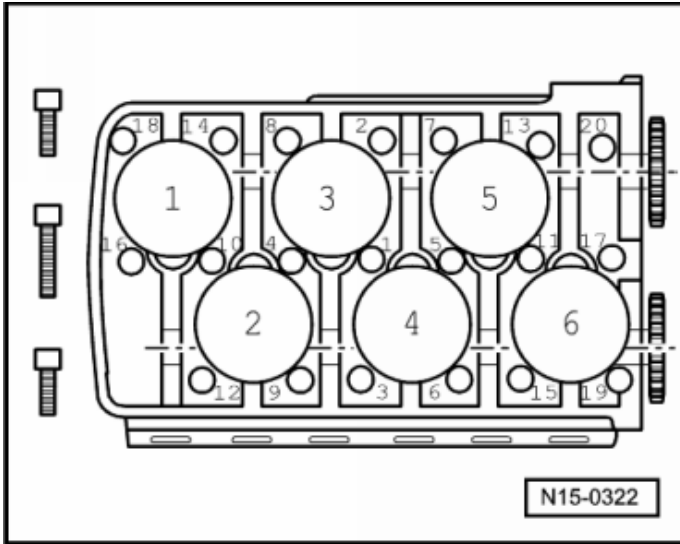

Step	Component	Nm
1	Tighten bolts 1 through 20 in sequence	15
2	Tighten bolts 1 through 20 in sequence	30
3	Tighten bolts 1 through 20 in sequence	an additional 90° (¼ turn)
4	Tighten bolts 1 through 20 in sequence	an additional 90° (¼ turn)

## Camshaft Bearing Cap Tightening Specifications

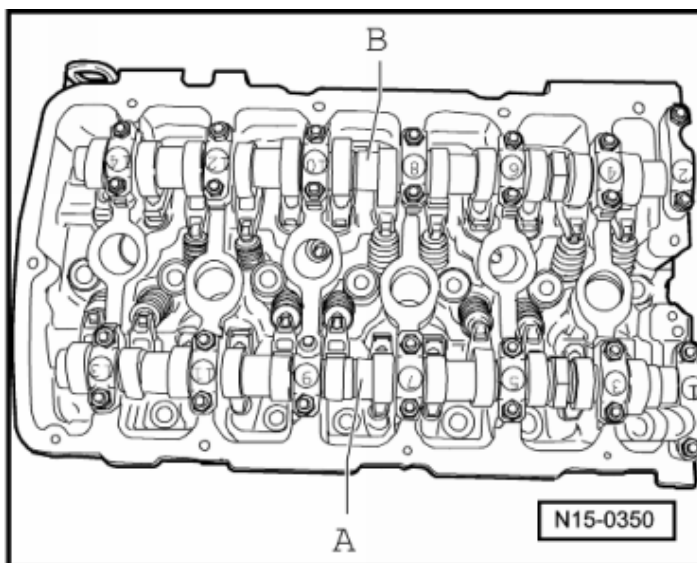

Engine –  
3.6L CGRA

Step	Component	Nm
<b>A - Intake Camshaft</b>		
1	Alternately tighten bearing caps 5 and 9 and in a diagonal sequence	5 plus an additional 45° (1/8 turn)
2	Alternately tighten bearing caps 1 and 13 and in a diagonal sequence	5 plus an additional 45° (1/8 turn)
3	Tighten bearing cap 7	5 plus an additional 45° (1/8 turn)
4	Alternately tighten bearing caps 3 and 11 and in a diagonal sequence	5 plus an additional 45° (1/8 turn)
<b>B - Exhaust Camshaft</b>		
1	Alternately tighten bearing caps 6 and 10 and in a diagonal sequence	5 plus an additional 45° (1/8 turn)
2	Alternately tighten bearing caps 2 and 14 and in a diagonal sequence	5 plus an additional 45° (1/8 turn)
3	Tighten bearing cap 8	5 plus an additional 45° (1/8 turn)
4	Alternately tighten bearing caps 4 and 12 and in a diagonal sequence	5 plus an additional 45° (1/8 turn)

## Cylinder Head Cover Tightening Specification

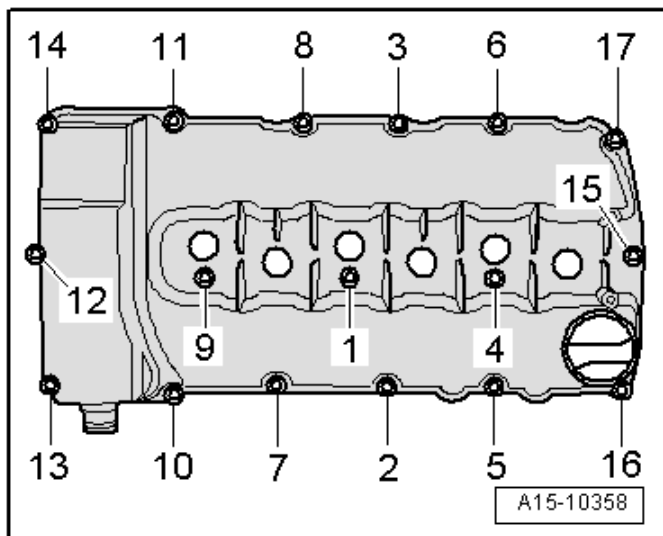

Step	Component	Nm
1	Tighten bolts 1 through 17 in sequence	10

## Engine Lubrication – 3.6L CGRA

### Fastener Tightening Specifications

Component	Nm
Baffle plate-to-oil pan bolt	10
Filter housing-to-oil filter housing/engine mount bracket	25
Oil dipstick guide tube-to-intake manifold bolt	6
Oil filter housing drain plug	10
Oil filter housing/engine mount cover bracket	25
Oil level thermal sensor-to-oil pan bolt	10
Oil pan drain plug <sup>1</sup>	30
Oil pan-to-cylinder block bolt	12
Oil pipe-to-cylinder block bolt <sup>2)</sup>	8
Oil pressure switch-to-oil filter housing/engine mount bracket	20
Oil pump-to-cylinder block bolt <sup>1)2)</sup>	8
Oil pump locking bolt	32
Oil pump sprocket bolt <sup>1)</sup>	60 plus an additional 90° (¼ turn)
Suction pipe-to-cylinder block bolt <sup>2)</sup>	8

<sup>1)</sup> Replace fastener(s).

<sup>2)</sup> Install using liquid locking fluid (D 000 600 A2).

## Cooling System – 3.6L CGRA

### Fastener Tightening Specifications

Component	Nm
Adapter-to-cylinder block bolt	10
Coolant line-to-intake manifold bolt	6
Coolant pump-to-cylinder block bolt	8
Coolant pump pulley-to-coolant pump bolt	20
Cylinder head connecting piece bolt	10
Engine temperature control temperature sensor-to-cylinder head bolt	5
Radiator lower mount bolt	25
Radiator upper mount bolt	5
Thermostat housing cover bolt	5

Engine –  
3.6L CGRA

## Fuel Supply – 3.6L CGRA

### Fastener Tightening Specifications

Component	Nm
Accelerator Pedal Position (APP) sensor with Accelerator Pedal Position 2 (APP2) sensor-to-body bolt	10
Evaporative Emission (EVAP) canister-to-underbody bolt	9
Fuel filler tube-to-body bolt <sup>1)</sup>	5
	9
	9
Fuel tank securing strap-to-underbody bolt	33
Fuel tank locking ring	145
Leak Detection Pump (LDP)-to-Evaporative Emission (EVAP) canister bracket bolt	5

<sup>1)</sup> For bolt tightening clarification, refer to ElsaWeb, *EVAP System Overview*, items 2, 5 and 6.

# Exhaust System, Emission Controls – 3.6L CGRA

## Fastener Tightening Specifications

Component	Nm
Clamping sleeve	35
Exhaust manifold-to-cylinder head nut <sup>1)</sup>	25
Exhaust pipe with catalytic converter bracket bolt	23
Exhaust pipe with catalytic converter-to-exhaust manifold nut <sup>1)</sup>	23
Exhaust manifold heat shield-to-intake manifold bolt	20
Intake manifold support-to-exhaust manifold/heat shield bolt	20
Suspended mount-to-underbody bolt	23
Tailpipe clamp	60

<sup>1)</sup> Replace fastener(s).

## Multiport Fuel Injection – 3.6L CGRA

### Technical Data

Engine codes	CGRA
<b>Idle check</b>	
Engine idle speed	600 to 800 RPM
<b>Engine Control Module (ECM)</b>	
System designation	Motronic MED 17
Part number	Refer to the Electronic Parts Catalog (ETKA)
Engine speed limitation	Approximately 6200 RPM

## Fastener Tightening Specifications

<b>Component</b>	<b>Nm</b>
Fuel rail union connecting piece nut	28
Connection to high pressure pump	
- For the low pressure hose	28
- For the high pressure pipe	40
Coolant line-to-lower intake manifold bolt	3.5
Fuel pressure sensor-to-fuel rail <sup>2)</sup>	22
Fuel pressure sensor-to-pressure sensor tester (VAS 6394)	22
Fuel rail plug	22
Fuel rail-to-lower intake manifold bolt <sup>1)</sup>	30 plus an additional 90° (¼ turn)
Fuel supply line union nut	30
High pressure fuel pipe union nut-to-fuel rail union nut	28
High pressure fuel pipe union nut-to-high pressure pump connection	28
High pressure pump-to-cylinder head bolt	8
Intake manifold support-to-upper intake manifold bolt	20
Intake manifold vent line bolt	3.5
Low fuel pressure sensor-to-fuel supply line	15
Lower air filter housing-to-body bolt	10
Lower intake manifold-to-cylinder head bolt	8
Lower intake manifold mounting plate bolt	3.5
Mass Air Flow (MAF) sensor-to-upper air filter housing bolt	6
Pressure sensor tester (VAS 6394)-to-fuel rail <sup>2)</sup>	22
Throttle valve control module-to-intake manifold bolt	7
Upper air filter housing heat shield bolt	6
Upper intake manifold-to-intake manifold support bolt	10

<sup>1)</sup> Replace fastener(s).

<sup>2)</sup> Before installing, lubricate the front sealing point and threads with clean engine oil.

## Upper Intake Manifold to Lower Intake Manifold Tightening Specification

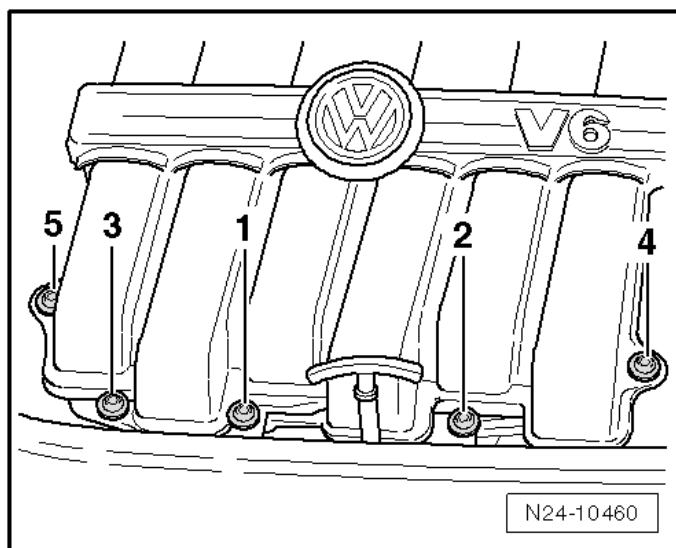

Step	Component	Nm
1	Tighten bolts 1 through 5 in sequence	10

## Ignition – 3.6L CGRA

### Technical Data

<b>Engine code</b>	<b>CGRA</b>
Ignition sequence	1-5-3-6-2-4
<b>Spark plugs</b> <sup>1)</sup>	
VW/Audi	101 905 622
Electrode gap	0.8 to 0.9 mm
Tightening specification	18 Nm
Change intervals	Refer to Maintenance Intervals Rep. Gr. 03

<sup>1)</sup> Remove and install spark plugs using the spark plug removal tool (3122 B).

### Fastener Tightening Specifications

Component	Nm
Camshaft Position (CMP) sensor bolt	10
Knock Sensor (KS) bolt	20
Knock Sensor (KS) wire harness bracket bolt	20
Spark plug	18



# AUTOMATIC TRANSMISSION – 0C8

## General, Technical Data

### Transmission Identification

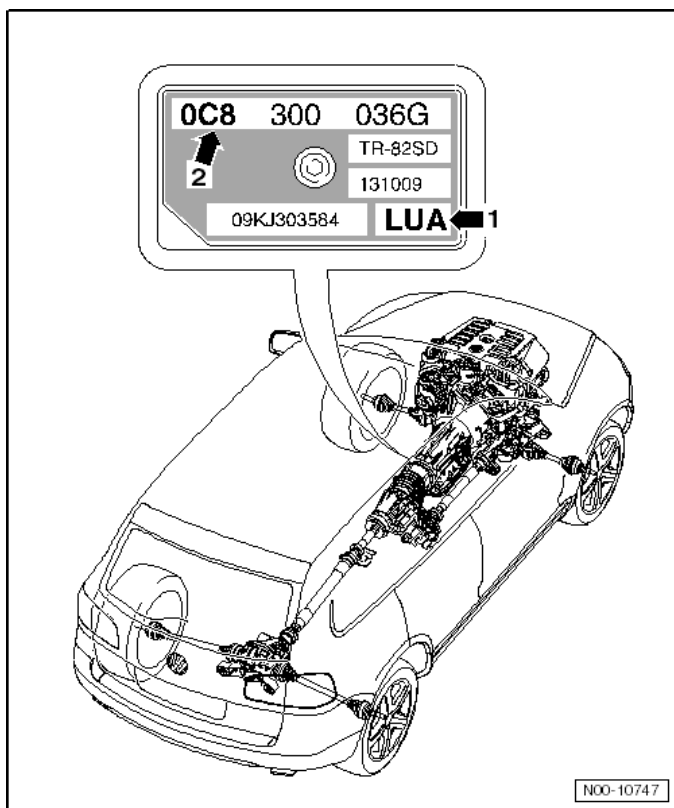

Transmission code letters are located on the type plate on the bottom left side of the transmission.

#### Example:

1 - Code Letters

2 - Automatic Transmission 0C8

NOTE: The transmission code letters are also included on the vehicle data labels.

Automatic Trans. –  
0C8

## Code Letters and Transmission Allocations Vehicles with a Hybrid Engine

Engine	Transmission code
3.0L - 245 kW V6	LUA, MXP, NNP

## Vehicles with a Gas Engine

Engine	Transmission code
3.6L - 206 kW VR6	LSK

## Vehicles with a Diesel Engine

Engine	Transmission code
3.0L - 165 kW V6	MHC, NAB

## *Torque Converter*

### Fastener Tightening Specifications

Component	Nm
Torque converter drive plate bolt	85
Flange (for the starter)-to-transmission bolt <sup>1)</sup>	20

<sup>1)</sup> 3.0L TFSI engine only.

# Controls, Housing – 0C8

## Fastener Tightening Specifications

Component	Nm
Catalytic converter bracket-to-transmission bolt <sup>3)</sup>	20
Selector housing-to-body bolt	10
Selector housing-to-bracket bolt	6.5
Selector lever cable set screw	10
Selector lever sensor system control module with Tiptronic switch-to-selector mechanism screw	6.5
Selector mechanism-to-body/selector housing bolt	6.5
Torque converter-to-drive plate bolt <sup>2)</sup>	60
Transmission fluid pipe-to-automatic transmission bolt <sup>1)</sup>	20
Transmission fluid pipe-to-automatic transmission fluid pre-heater bolt <sup>1)</sup>	8
Transmission fluid auxiliary hydraulic pump-to-transmission bolt <sup>2)</sup>	32
Transmission fluid pipe clamp-to-automatic transmission bolt	20
Transmission fluid pipe clamp-to-catalytic converter bracket bolt <sup>3)</sup>	8
Transmission fluid pipe heat shield bolt <sup>3)</sup>	8
Transmission fluid pipe-to-thermostat bolt <sup>1)</sup>	20
Transmission fluid pre-heater-to-automatic transmission bolt	20
Transmission oil pan drain plug	16
Transmission oil pan overflow tube	2

<sup>1)</sup> Before tightening the bolt, push in the pipe by hand, until seated.

<sup>2)</sup> 3.0L hybrid engine only.

<sup>3)</sup> 3.6L engine only.

## Securing Transmission to a 3.0L Hybrid Engine

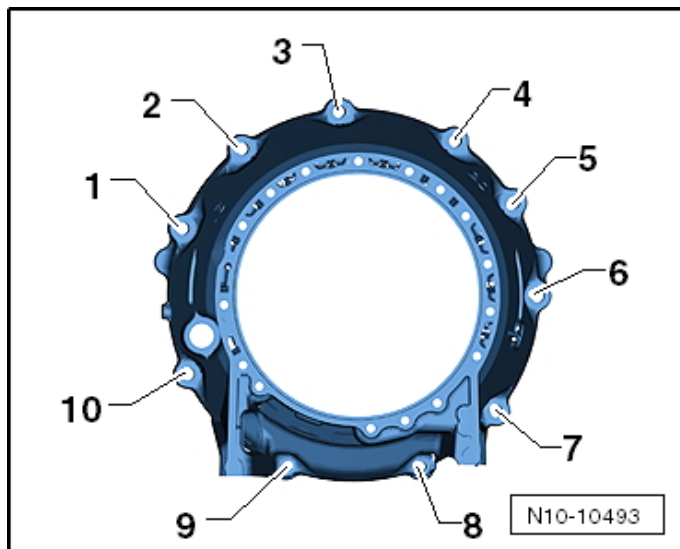

Step	Component	Nm
1	Tighten bolts 1 through 10 in sequence	30 plus an additional 90° (¼ turn)

## Securing Transmission to a 3.0L TDI Engine

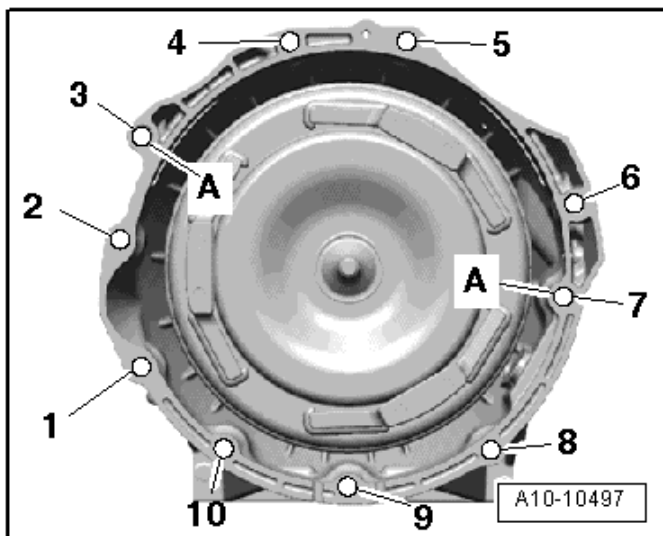

Item	Fastener	Nm
1 <sup>1)</sup> 2)	M10 x 70	65
2 <sup>1)</sup>	M10 x 90	65
3, 4, 5 and 7	M12 x 80	80
6	M12 x 70	80
8, 9 and 10 <sup>2)</sup>	M10 x 70	45
A	Alignment sleeves	
Torque converter drive plate		85

<sup>1)</sup> Also secures the starter.

<sup>2)</sup> Installed from the engine side.

## Securing Transmission to a 3.6L Engine

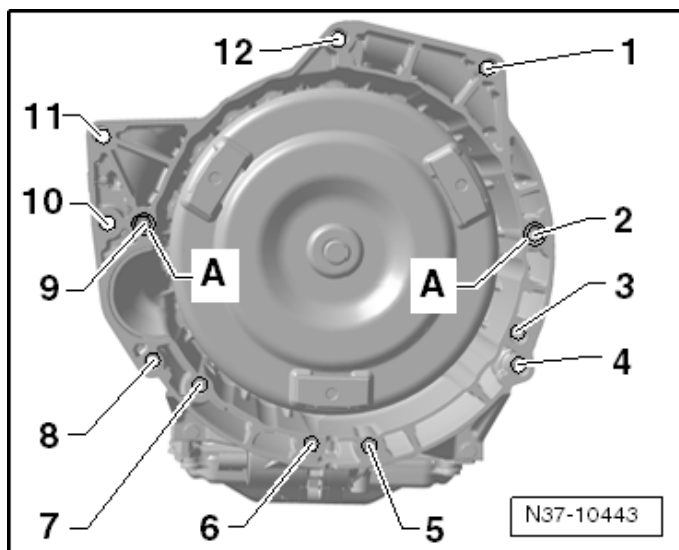

Item	Fastener	Nm
1 and 12	M12 x 50	80
2 and 3	M12 x 140	80
4, 5, 6 and 7 <sup>2)</sup>	M10 x 80	45
8 and 9 <sup>1) 2)</sup>	M12 x 60	80
11	M12 x 60	80
A	Alignment sleeves	
Torque converter drive plate		85

<sup>1)</sup> Also secures the starter.

<sup>2)</sup> Installed from the engine side.

**NOTE:** Position 10 does not have a bolt

# Gears, Hydraulic Controls – 0C8

## Fastener Tightening Specifications

Component	Nm
Overflow tube-to-transmission fluid pan	2
Transmission fluid filter-to-valve body/transmission bolt	10
Transmission fluid pan drain plug	8
Transmission fluid pan-to-transmission bolt	8
Valve body-to-transmission bolt <sup>1)</sup>	8 plus an additional 90° (¼ turn)

<sup>1)</sup> Tighten the bolts diagonally.

## Valve Body Tightening Specifications

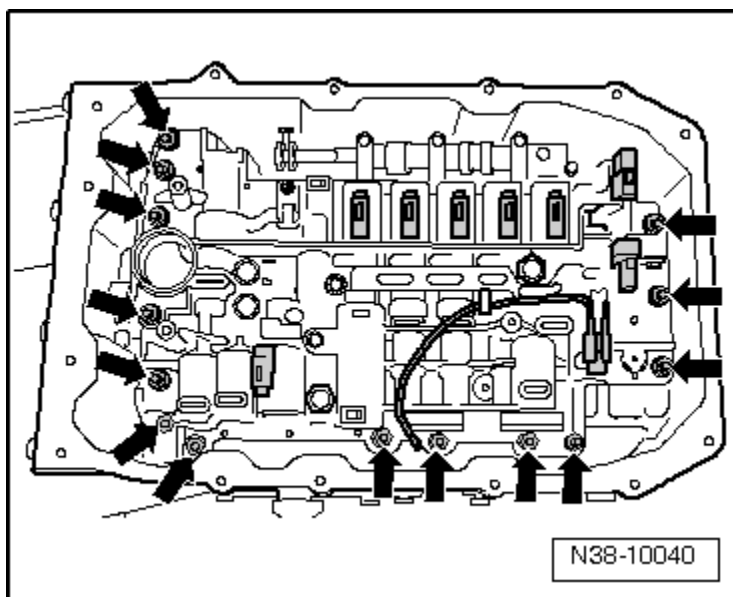

Automatic Trans. –  
0C8

Step	Component	Nm
1	Tighten bolts (➡) diagonally	Hand-tighten
2	Tighten bolts (➡) diagonally	8
3	Tighten bolts (➡) diagonally	an additional 90° (¼ turn)

# TRANSFER CASE AND FINAL DRIVE

## *General, Technical Data*

### Transfer Case Identification Location

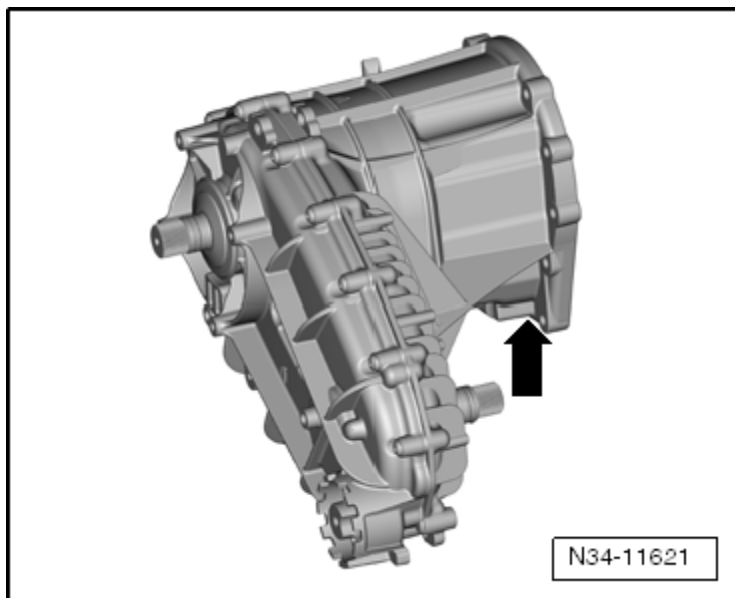

Transfer case 0BU or 0BV, code letters and dates of manufacture (➡).



## Transfer Case Identification

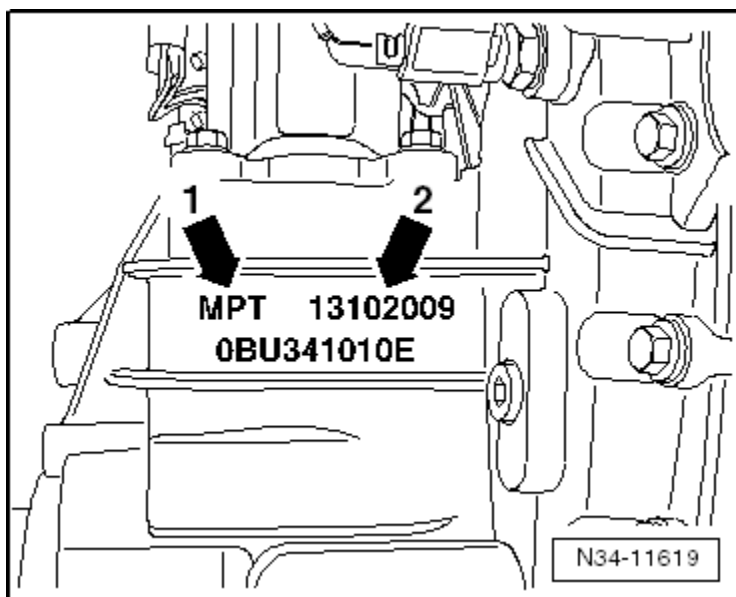

- 1- Transfer case code letters.
- 2- Transfer case build date.

### Example:

<b>MPT</b>	<b>13</b>	<b>10</b>	<b>2009</b>
Code letters	Day	Month	Year (2009) of manufacture

## Transfer Case Code Letter, Allocation and Capacities

Transfer case		0BU	
Identification case codes		MTT, NCF and NDZ	LER, MTK, MTJ, MZV, NCA, NCB and NMU
Allocation	Type	Touareg from MY 2010	Touareg from MY 2010
Engine		3.0L - 245 kW V6 Hybrid	3.0L - 165 kW Turbo Diesel
Capacity		Refer to Fluid Capacity Tables Rep. Gr. 03	

Transfer Case		0BU	0BV
Identification codes		MTK, NCB, NMV	MEH
Allocation	Type	Touareg from MY 2010	Touareg from MY 2010
Engine		3.6L - 206 kW VR6 Gas	3.6L - 206 kW VR6 Gas
Capacity		Refer to Fluid Capacity Tables Rep. Gr. 03	

Refer to the Electronic Parts Catalog (ETKA) for the following data:

- Allocation for the proper vehicle via the code letters on the automatic transmission and PR number.
- Transmission fluid specification.

## Controls, Housing

### Fastener Tightening Specifications

Component	Fastener size	Nm
Balance weight-to-transfer case bolt	-	50
Transfer case drain/fill plug <sup>2)</sup>	-	17
Transfer case carrier bracket-to-transfer case bolt	M8 x 35	20
	M8 x 70	20
Transfer case carrier bracket-to-transfer case carrier bolt <sup>1)</sup>	-	50 plus an additional 90° (¼ turn)
Transfer case carrier-to-underbody bolt <sup>1)</sup>	M10 x 80	50 plus an additional 90° (¼ turn)
Transfer case end balancer-to-transfer case bolt	-	32
Transfer case-to-transmission bolt	-	20 plus an additional 90° (¼ turn)

<sup>1)</sup> Replace fastener(s).

<sup>2)</sup> Install using liquid locking fluid (AMV 185 101 A1).

# Front Final Drive – 0BM, 0C1

## Front Final Drive Identification Location

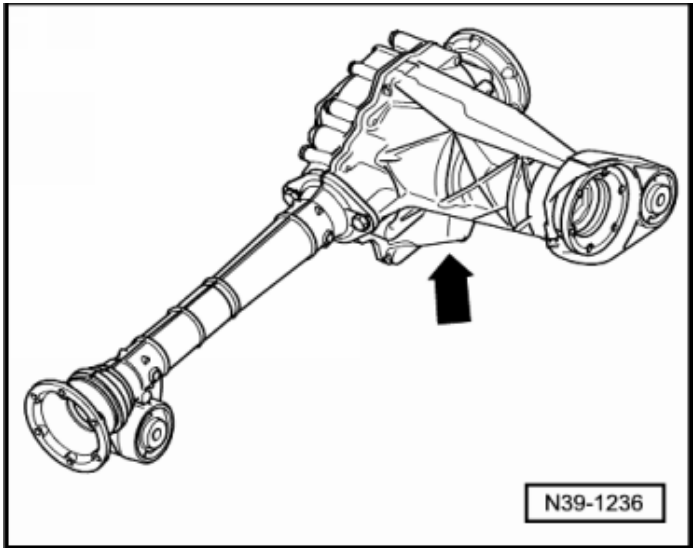

Front final drive 0BM, 0C1, code letters and dates of manufacture (➡).

## Front Final Drive Identification

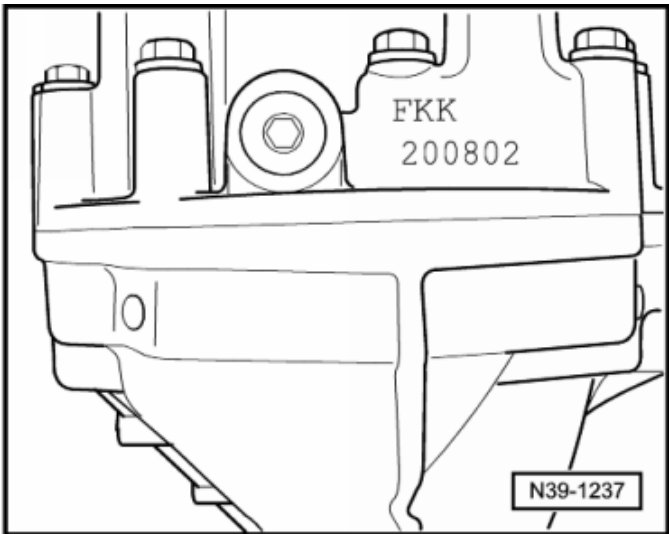

### Example:

FKK	20	08	02
Identification codes	Day	Month	Year of production (2002)

Transfer Case  
and Final Drive

## Front Final Drive Code Letters, Allocation, Ratios and Capacities

Front final drive		0BM	
Identification codes		MUN	MES
Allocation	Type	Touareg from MY 2010	Touareg from MY 2010
	Engine	3.0L - 245 kW V6 Hybrid	3.6L - 206 kW VR6 Gas
Ratio: $Z_1: Z_2$	Final drive	36:11 = 3.273	37:10 = 3.700
Capacity		Refer to the Fluid Capacity Tables Rep. Gr. 03	

Front final drive		0BM	0C1
Identification code		MUN	MUM
Allocation	Type	Touareg from MY 2010	Touareg from MY 2010
	Engine	3.0L - 165 kW Turbo Diesel	3.6L - 206 kW VR6 Gas
Ratio: $Z_1: Z_2$	Final drive	36:11 = 3.273	37:10 = 3.700
Capacity		Refer to the Fluid Capacity Tables Rep. Gr. 03	

Refer to the Electronic Parts Catalog (ETKA) for the following data:

- Allocation of the flange shafts.
- Vehicle allocation according to the engine code.
- Fluid specification.

## **Rear Final Drive – 0BN, 0BP**

### Rear Final Drive Identification Location

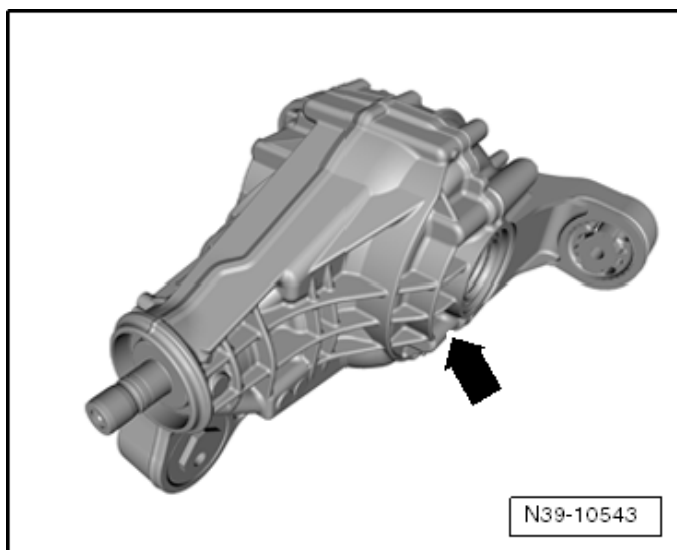

Rear final drive 0BN, 0BP code letters and dates of manufacture (➡).

## Rear Final Drive Identification

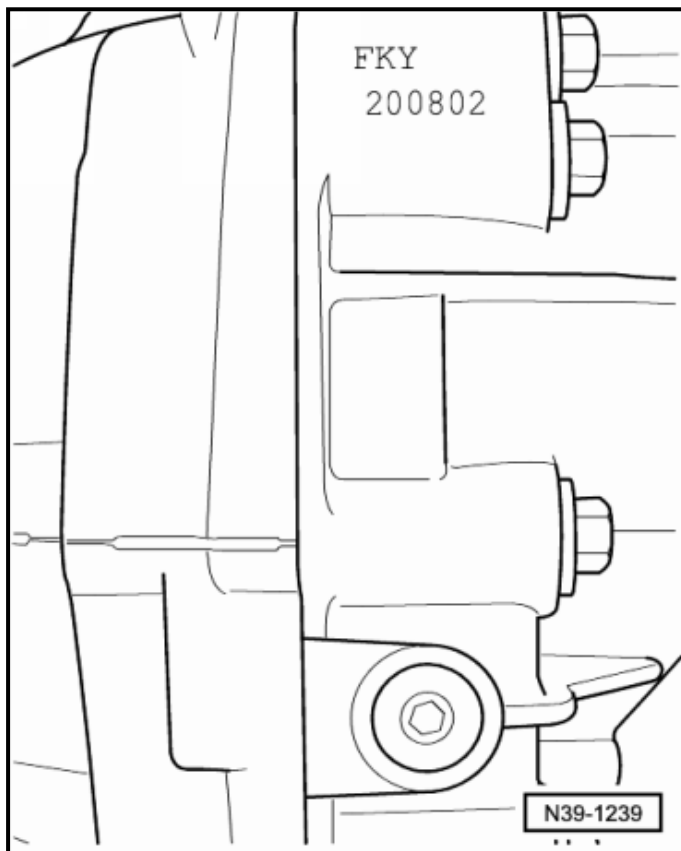

### Example:

<b>FKY</b>	<b>20</b>	<b>08</b>	<b>02</b>
Identification codes	Day	Month	Year of production (2002)

## Rear Final Drive Code Letters, Allocation, Ratios and Capacities

Rear final drive		0BN	0BP
Identification codes		MFF	MEX, NKX
Allocation	Type	Touareg from MY 2010	Touareg from MY 2010
	Engine	3.6L - 206 kW Gas	3.0L - 245 kW V6 Hybrid
Ratio: $Z_2: Z_1$	Final drive	37:10 = 3.700	36:11 = 3.273
Capacity		Refer to Fluid Capacity Table Rep. Gr. 03	
Electromechanical differential lock		With	Without

Rear final drive		0BP	
Identification codes		MEX	MEY
Allocation	Type	Touareg from MY 2010	Touareg from MY 2010
	Engine	3.0L - 165 kW Turbo Diesel	3.6L - 206 kW VR6 Gas
Ratio: $Z_2: Z_1$	Final drive	36:11 = 3.273	37:10 = 3.700
Capacity		Refer to Fluid Capacity Table Rep. Gr. 03	
Electromechanical differential lock		Without	Without

Refer to the Electronic Parts Catalog (ETKA) for the following data:

- Vehicle allocation according to the engine code.
- Fluid specification.

## Fastener Tightening Specifications

Component	Nm
Differential lock motor-to-rear final drive bolt	8
Driveshaft center support-to-underbody bolt	20
Front final drive filler plug	35
Rear final drive filler plug	35
Transfer case end balancer-to-transfer case bolt	32
Underbody bracket bolt	60

# SUSPENSION, WHEELS, STEERING

## Front Suspension

### Fastener Tightening Specifications

Component	Nm
Cable bracket-to-wheel bearing housing bolt	20
Constant Velocity (CV) joint boot clamp	25
Coupling rod-to-shock absorber nut <sup>1)</sup>	110
Coupling rod-to-stabilizer bar nut <sup>1)</sup>	110
Cover-to-air brake bolt	9
Cover plate-to-wheel bearing housing bolt (18" suspension)	9
Drive axle-to-final drive bolt <sup>1)</sup>	50 plus an additional 90° (¼ turn)
Drive axle-to-wheel hub nut <sup>1)</sup>	500
Front final drive-to-subframe bolt/nut <sup>1)</sup>	90 plus an additional 90° (¼ turn)
Front wheel speed sensor-to-wheel bearing housing bolt	8
Lower control arm-to-subframe nut <sup>1)</sup>	170
Lower control arm-to-wheel bearing housing nut <sup>1)</sup>	
- 17" suspension, cast steel	110
- 18" suspension, cast aluminum	130
Mass damper-to-subframe bolt (V6 TDI) <sup>1)</sup>	60
Pressure holding valve air line	4
Pressure holding valve-to-air spring	12
Shock absorber-to-body nut	60
Shock absorber-to-lower control arm nut <sup>1)</sup>	150 plus an additional 90° (¼ turn)
Shock absorber-to-mounting plate nut (steel spring shock absorber) <sup>1)</sup>	56
Shock absorber-to-rubber mount nut (air spring damper) <sup>1)</sup>	70
Stabilizer bar-to-subframe bolt <sup>1)</sup>	60
Subframe-to-body bolt <sup>1)</sup>	120 plus an additional 180° (½ turn)
Tie rod-to-wheel bearing housing nut <sup>1)</sup>	90

## Fastener Tightening Specifications (cont'd)

Component	Nm
Upper control arm-to-body bolt/nut <sup>1) 2)</sup>	50 plus an additional 90° (¼ turn)
Upper control arm-to-wheel bearing housing <sup>1)</sup>	85
Wheel bearing housing bracket bolt	9
Wheel bearing housing cover plate bolt (17" suspension)	20
Wheel bearing unit-to-wheel bearing housing (18"/19" suspension)	80 plus an additional 120° (½ turn)

<sup>1)</sup> Replace fastener(s).

<sup>2)</sup> Tighten the bolts in the curb weight position.

## Rear Suspension

### Fastener Tightening Specifications

Component	Nm
ABS wheel speed sensor bolt	8
Air spring cover bolt	27
Air spring shock absorber-to-rubber mount <sup>1)</sup>	70
Brake carrier plate-to-wheel bearing housing bolt	8
Cable bracket-to-wheel bearing housing bolt	10
Constant Velocity (CV) joint boot clamp	25
Coupling rod-to-stabilizer bar nut <sup>1), 2)</sup>	100
Drive axle-to-wheel hub nut <sup>1)</sup>	500
Lower transverse link-to-front subframe bolt <sup>1)</sup>	150 plus an additional 90° (¼ turn)
Lower transverse link-to-rear subframe nut <sup>1)</sup>	170
Lower transverse link-to-wheel bearing housing nut <sup>1)</sup>	150 plus an additional 90° (¼ turn)
Pressure holding valve-to-air spring	12
Rear final drive-to-subframe bolt/nut <sup>1)</sup>	90 plus an additional 90° (¼ turn)
Shock absorber-to-body bolt <sup>1), 3)</sup>	50 plus an additional 180° (½ turn)
Shock absorber and coupling rod-to-wheel bearing housing nut <sup>1)</sup>	90 plus an additional 90° (¼ turn)
Stabilizer bar-to-subframe bolt <sup>1), 2)</sup>	50



Component	Nm
Steel spring shock absorber-to-support bearing nut <sup>1)</sup>	56
Subframe stone protection plate bolt	1
Subframe-to-body bolt <sup>1)</sup>	120 plus an additional 180° (½ turn)
Support bearing cover-to-steel spring shock absorber mount nut <sup>1)</sup>	26
Tie rod-to-subframe nut <sup>1) 2)</sup>	170
Tie rod-to-wheel bearing housing <sup>1) 2)</sup>	150 plus an additional 90° (¼ turn)
Upper transverse link-to-subframe nut <sup>1) 2)</sup>	90 plus an additional 90° (¼ turn)
Upper transverse link-to-wheel bearing housing bolt <sup>1) 2)</sup>	150 plus an additional 90° (¼ turn)
Wheel bearing-to-wheel bearing housing bolt <sup>1)</sup>	80 plus an additional 120° (½ turn)

<sup>1)</sup> Replace fastener(s).

<sup>2)</sup> Always tighten the threaded connection in the curb weight position.

<sup>3)</sup> Tighten in sequence. Refer to ElsaWeb, *Steel Spring Shock Absorber or Air Spring Damper*.

## Self-Leveling Suspension

### Fastener Tightening Specifications

Component	Nm
Accumulator-to-body bolt	20
Adaptive suspension valve block bolt	7
Air line	4
Compressor bracket-to-body bolt	20
Compressor with adaptive suspension valve block bracket bolts	5
Compressor with adaptive suspension valve block bracket nut	6
Front body acceleration sensor-to-body bolt	8
Front level control system sensor-to-body bolt	9
Level control system control module-to-bracket nut	6
Rear level control system sensor-to-subframe bolt	5
Rear level control system sensor-to-upper transverse link nut	8

# Wheels, Tires

## Fastener Tightening Specifications

Component	Nm
Metal valve-to-wheel nut	4
Rear tire pressure monitoring transmitter in wheel housing-to-body bolt	6
Tire pressure monitoring control module-to-body bolt	6
Tire pressure sensor-to-metal valve bolt	4
Wheel bolt	180

## Wheel Alignment Data

### Wheel Alignment Specified Values

Specifications valid for all engine versions

Front suspension	Steel spring shock absorber		Air spring shock absorber	
	1BA/1BE	1BB	1BK/1BY	2MA
Production Relevant No. (PR. No.)				
Toe-in per wheel (each wheel)	+5' ± 2.5'	+5' ± 2.5'	+5' ± 2.5'	+5' ± 2.5'
Maximum permissible difference between both sides	5'	5'	5'	5'
Camber (wheels in straight ahead position)	-15' ± 20'	-15' ± 20'	-15' ± 20'	-15' ± 20'
Maximum permissible difference between both sides	20'	20'	20'	20'
Caster angle	+8° 35' +10'/-30'	+8° 26' +10'/-30'	+8° 38' +10'/-30'	+9° 5' +10'/-30'
Maximum permissible difference between both sides	30'	30'	30'	30'
Standing height (in.)	478 ± 0.39	488 ± 0.39	475 ± 0.39	450 ± 0.39

## Wheel Alignment Specified Values (cont'd)

Specifications valid for all engine versions

Rear suspension	Steel spring shock absorber		Air spring shock absorber	
	1BA/1BE	1BB	1BK/1BY	2MA
Production Relevant No. (PR. No.)	1BA/1BE	1BB	1BK/1BY	2MA
Toe-in per wheel (each wheel)	+10' ± 5'	+10' ± 5'	+10' ± 5'	+10' ± 5'
Maximum permissible difference between both sides	7'	7'	7'	7'
Camber	-1° 20' ± 20'	-1° 20' ± 20'	-1° 20' ± 20'	-1° 20' ± 20'
Maximum permissible difference between both sides	20'	20'	20'	20'
Standing height (in.)	486 ± 0.39	502 ± 0.39	483 ± 0.39	458 ± 0.39

## Steering

### Fastener Tightening Specifications

Component	Nm
Belt pulley-to-power steering pump bolt (Gas and Diesel engine)	22
Electronic steering column lock control module-to-steering column bolt	5
Oil cooler bracket bolt	9
Power adjustable steering column control module-to-steering column bolt	5
Power steering gear-to-subframe nut <sup>1)</sup>	90 plus an additional 90° (¼ turn)
Power steering pump bracket bolt (Hybrid engine)	9
	25
Power steering pump bracket bolt (Gas and Diesel engine)	22
Power steering pump rubber mount (Hybrid engine)	8
Pressure line-to-power steering pump bolt (Gas and Diesel engine)	9
Pressure line-to-power steering pump bolt (Hybrid engine)	20
Rubber mount-to-power steering pump bracket nut (Hybrid engine)	8
Steering column boot-to-body nut	4

## Fastener Tightening Specifications (cont'd)

Component	Nm
Steering column-to-cross member bolt/nut <sup>1)</sup>	20
Steering column-to-steering gear bolt <sup>1)</sup>	20 plus an additional 90° (¼ turn)
Steering gear heat shield bolt	9
Steering gear lines retaining bolt	9
Steering gear line union fitting	32
Steering wheel-to-steering column bolt <sup>1)</sup>	30 plus an additional 90° (¼ turn)
Tie rod-to-steering gear	100
Tie rod-to-tie rod nut	70
Tie rod end-to-wheel bearing housing nut <sup>1)</sup>	90

<sup>1)</sup> Replace fastener(s).

# BRAKE SYSTEM

## General Information

### Vehicle Data Label

FAHRZG.-IDENT-NR. VEHICLE-IDENT-NO	X000 45-7-4053 NU								
TYP./TYPE	WVG ZZZ 7P zB D 000157								
	7P5 2T3								
	Touareg		V8TDI		250 KW				
	TDI A8A								
WZT/FKZ-GRUPPE ENG.CODE/TRANS CODE	CKD		LSG						
LACKNR./INNENAUSST. PAINT NO./INTERIOR	LX7W		KJ						
W.-AUSSERSTELLUNGS									
X9X	B0A	CV6	G1G	HQ2	J0P	D57	Q2J		
-	1AT	1GB	1MR	1NE	5RQ	5SL	TE5		
	3S1		QG1		8AY	8GH	8ZH		
	1KJ	1LG				7MG			
	4M	4N	4X4		4F2	N5E	5MN		
9VE	0JC	0YB	2MA						

N00-10725

The following brakes are installed in this example:

- 1 - Rear brakes - 1KJ
- 2 - Front brakes - 1LG

The vehicle data label can be found in the spare wheel well and the Maintenance booklet.

## Front Brakes

Engine version	PR number	Front wheel brake
3.0L - 176 kW TDI	1LE	Brembo (17")
3.6l - 206 kW FSI		
3.0L - 245 kW TSI, Hybrid	1LJ	Brembo (18")

## Rear Brakes

Engine version	PR number	Front wheel brake
3.0L - 176 kW TDI	1KQ	Brembo (17")
3.0L - 245 kW TSI, Hybrid		

## Brake Master Cylinder and Brake Booster

<b>Brake master cylinder</b>	Diameter in mm	26.99
<b>Brake booster</b>	Diameter in inches	9"/10"-Dual

## Front Brakes, Brembo 17 Inch

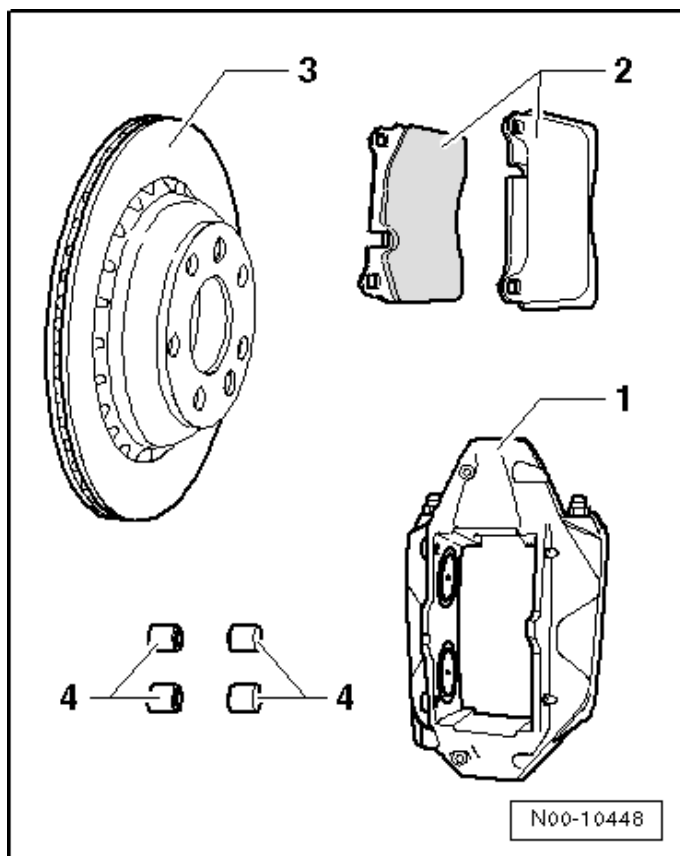

Item	PR Number	1LC / 1LE	
1	Brake caliper	Brembo (17")	
2	Brake pad thickness	mm	10.5
	Brake pad wear limit without back plate	mm	2
3	Brake disc	Diameter in mm	330
	Brake disc thickness	mm	32
	Brake disc wear limit	mm	30
4	Brake caliper piston	Diameter in mm	4 x 46

## Front Brakes, Brembo 18 Inch

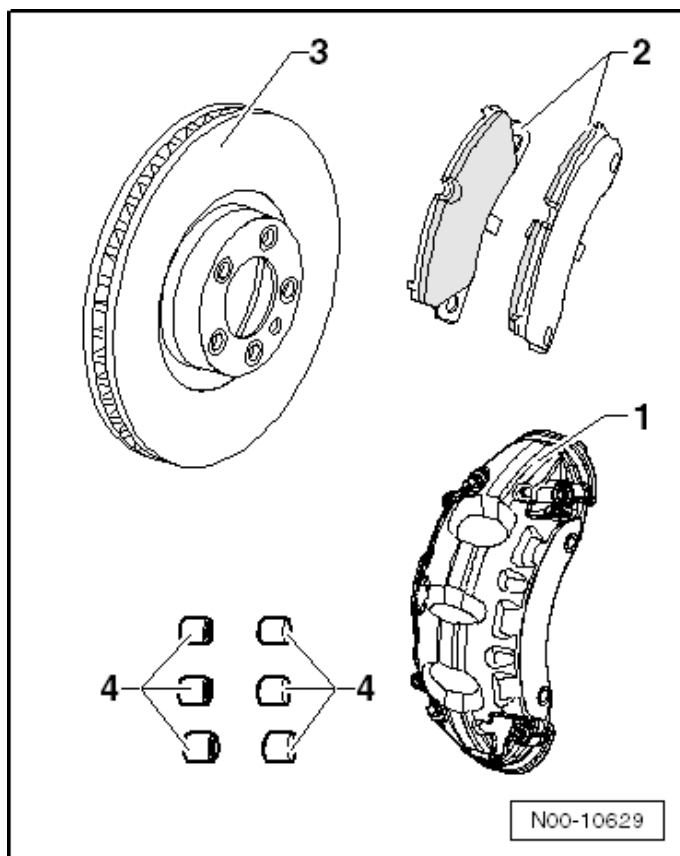

Item	PR Number		1LT / 1LU
1	Brake caliper		Brembo (18")
2	Brake pad thickness	mm	10
	Brake pad wear limit without back plate	mm	2
3	Brake disc	Diameter in mm	368
	Brake disc thickness	mm	36
	Brake disc wear limit	mm	34
4	Brake caliper piston	Diameter in mm	6 x 36



## Rear Disc Brakes

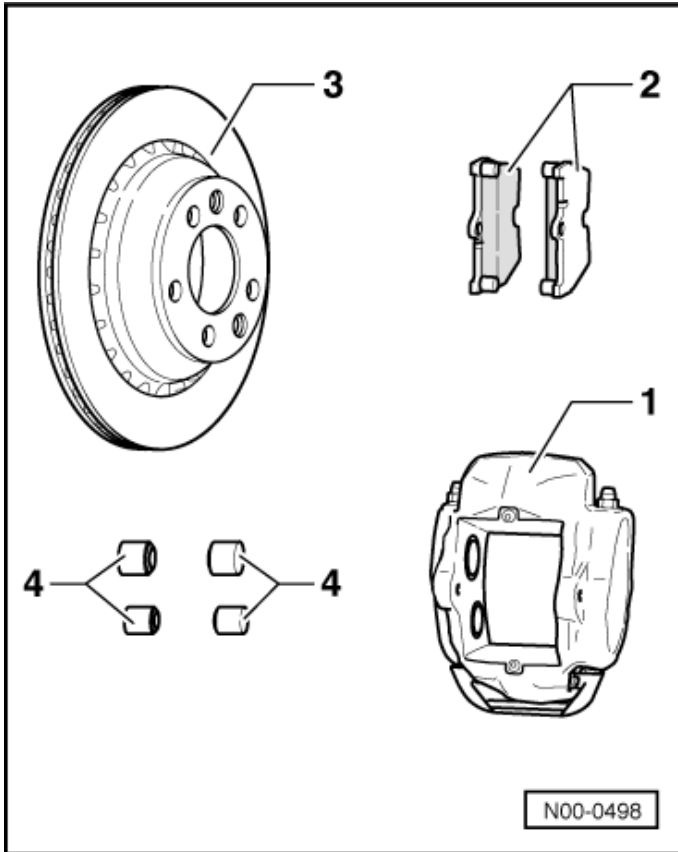

Item	PR Number	1KJ / 1KQ	
1	Brake caliper	Brembo (17")	
2	Brake pad thickness	mm	10
	Brake pad wear limit without back plate	mm	2
3	Brake disc	Diameter in mm	330
	Brake disc thickness	mm	28
	Brake disc wear limit	mm	26
4	Brake caliper piston	Diameter in mm	4 x 46

## Drum Parking Brake

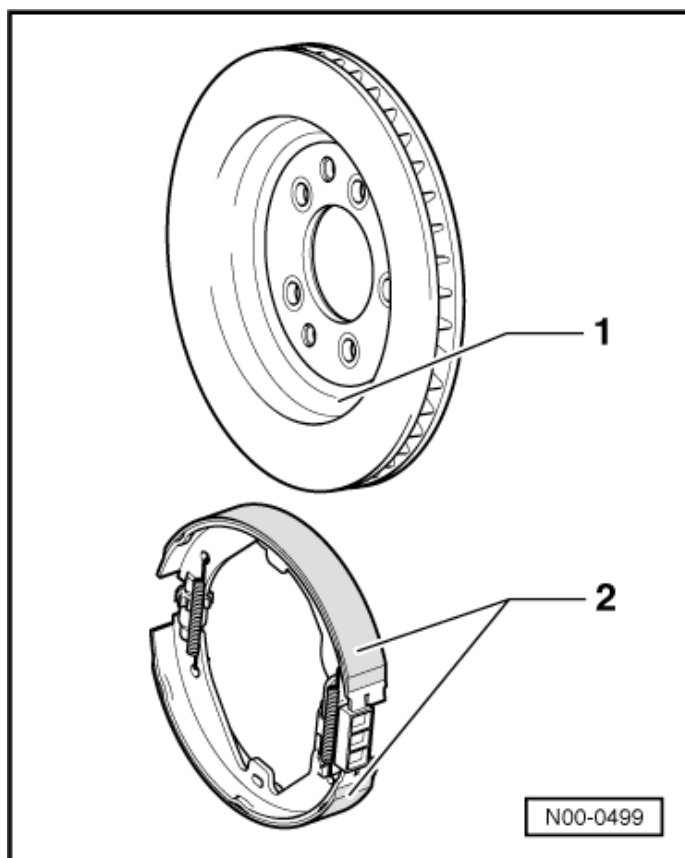

Item			
1	Brake drum	Diameter in mm	210
	Brake drum wear limit	Diameter in mm	211
2	Brake pad width	mm	30
	Brake pad total thickness	mm	5.5
	Brake pad wear limit without brake carrier	mm	1

# Anti-lock Brake System (ABS)

## Fastener Tightening Specifications

Component	Nm
ABS control module-to-ABS hydraulic unit bolt <sup>1)2)</sup>	2 + 0.8
ABS hydraulic control unit bracket bolt	9
ABS wheel speed sensor bolt	8
Brake lines-to-brake calipers (diameter 5.25 mm)	14
Brake master cylinder brake lines (diameter 8.5 mm)	18
ESP sensor unit nut	8

<sup>1)</sup> Replace fastener(s).

<sup>2)</sup> Tighten diagonally in steps without tilting.

## Mechanical Components

### Fastener Tightening Specifications

Component	Nm
Brake carrier plate-to-rear wheel bearing housing bolt	8
Brake disc-to-wheel hub bolt	15
Brake line-to-brake caliper	14
Brake pedal bracket bolt	3.5
Brake pedal position sensor bracket bolt (Hybrid)	3
Electromechanical parking brake adjusting nut bolt	15
Front brake caliper bolt <sup>1)</sup>	
- Brembo 17"	270
- Brembo 18"	30 plus an additional 90° (¼ turn)
Front wheel bearing housing lower bracket bolt	20
Front wheel bearing housing upper bracket bolt	9
Parking brake motor-to-wheel bearing housing bolt	65
Pedal assembly mounting bracket bolt	20
Pedal assembly mounting bracket support bolt	3
Rear brake caliper bolt <sup>1)</sup>	30 plus an additional 75°
Rear brake pad wear indicator bolt	8
Rear wheel bearing housing bracket bolt	10

<sup>1)</sup> Replace fastener(s).

# Hydraulic Components

## Fastener Tightening Specifications

Component	Nm
Brake booster-to-pedal assembly/bulkhead nut <sup>1)</sup>	23
Brake caliper bleeder valve	12
Brake light switch-to-master cylinder bolt	5
Brake master cylinder brake lines	18
Brake master cylinder-to-brake booster nut <sup>1)</sup>	23
Brake system vacuum pump bracket-to-console bolt	9
Brake system vacuum pump-to-bracket bolt/nut	7
Coolant pipe-to-brake system vacuum pump bracket bolt	8
Front brake caliper connecting line (Brembo 18")	17

<sup>1)</sup> Replace fastener(s).

# BODY

## Air Gap Body Dimensions

### Body, Front

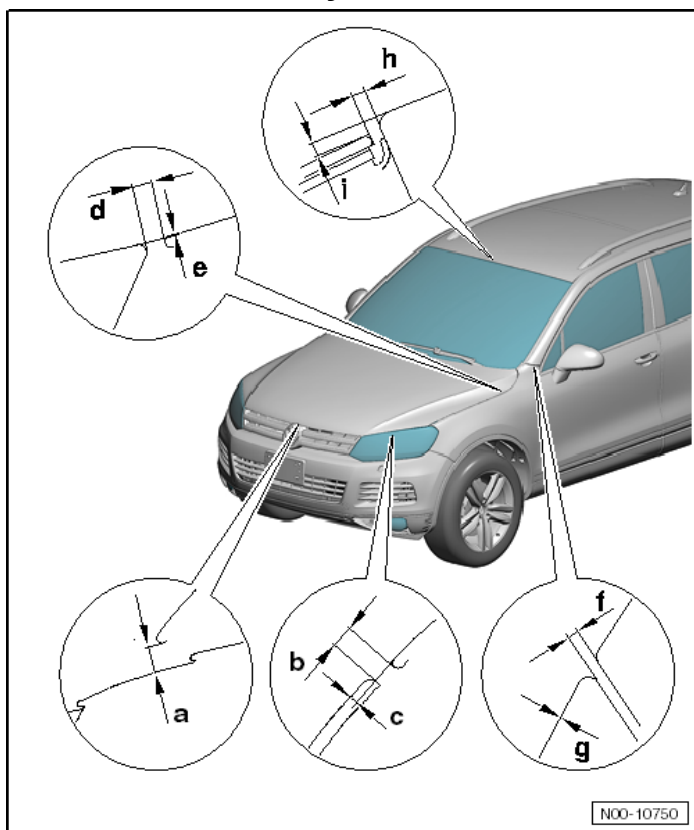

N00-10750

Component	mm
a	$5.0 \pm 0.5$
b	$4.5 \pm 0.5$
c	$0.8 \pm 0.5$
d	$3.7 \pm 0.5$
e	$0.1 \pm 0.5$
f	$2.0 \pm 0.8$
g	$0.0 \pm 0.5$
h	$2.6 \pm 0.5$
i	$2.7 \pm 0.5$

Body

## Body, Center

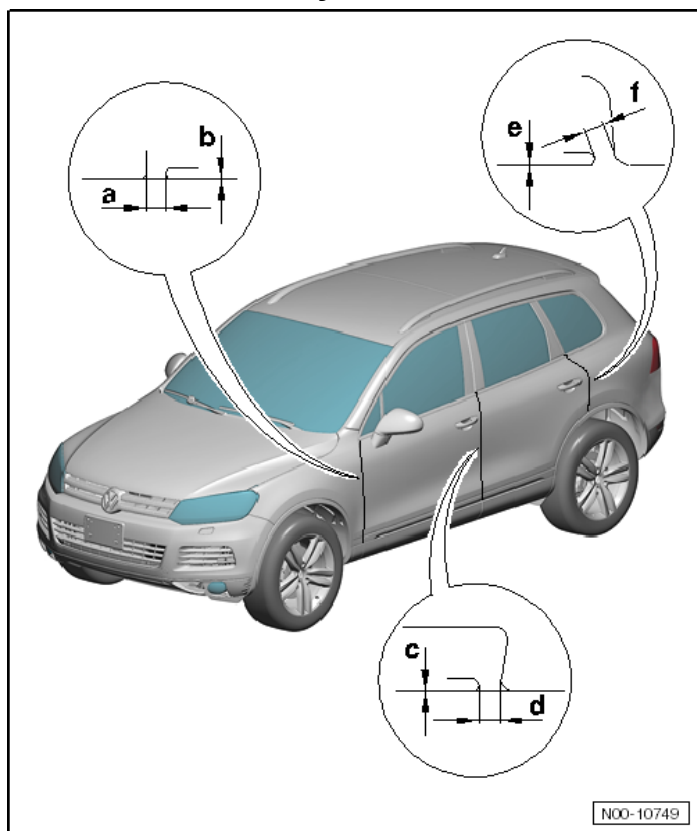

Component	mm
a	$3.7 \pm 0.5$
b	$0.0 \pm 1.0$
c	$0.0 + 1.0$
d	$4.2 \pm 0.5$
e	$0.0 + 1.0$
f	$3.7 \pm 0.5$

## Body, Rear

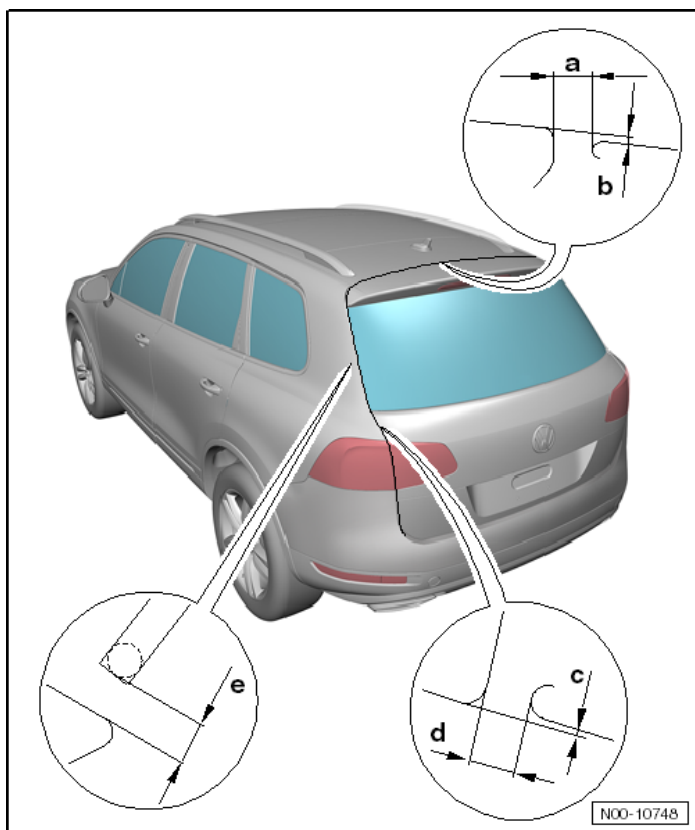

Body

Component	mm
a	$5.0 \pm 0.5$
b	$1.1 \pm 0.5$
c	$0.6 \pm 0.5$
d	$3.5 \pm 0.5$
e	$4.2 \pm 0.3$

## **Body Exterior**

### **Lock Carrier, Plenum Chamber Tightening Specifications**

<b>Component</b>	<b>Nm</b>
Lock carrier bolt	20
Lock carrier screw	8
Plenum chamber bolts	6

### **Front Fender, Noise Insulation and Underbody Trim Tightening Specifications**

<b>Component</b>	<b>Nm</b>
Front fender bolt	6
Noise insulation front and rear bolts	6
Underbody trim bolts/nuts	2

### **Front Hood Tightening Specifications**

<b>Component</b>	<b>Nm</b>
Front hood hinge bolt/nut	20
Front hood latch bolts	12
Front hood lock bolts	12
Front hood striker pin	12

### **Rear Lid and Fuel Filler Door Tightening Specifications**

<b>Component</b>	<b>Nm</b>
Fuel filler door bolts	1.5
Rear lid gas strut ball head pin	20 plus an additional 45° (1/8 turn)
Rear lid hinge bolt	10 plus an additional 90° (1/4 turn)
Rear lid lock bolts	8 plus an additional 45° (1/8 turn)
Rear lid release button protective cap screw	6
Rear lid striker pin nut	18



## Front and Rear Door Tightening Specifications

Component	Nm
<b>Front door <sup>1)</sup></b>	
Door hinge bolts	23
	50
Door lock screws	1.5
	3.5
	20
Door strap bolts	9
	30
Striker pin bolts	20
Subframe bolts	2
	8
<b>Rear door <sup>2)</sup></b>	
Door hinge bolts	9
	23
	30
	50
Door lock screws	1
	3.5
	20
Striker pin bolts	20

<sup>1)</sup> For bolt tightening clarification, refer to ElsaWeb, *Body Exterior, Front Doors*.

<sup>2)</sup> For bolt tightening clarification, refer to ElsaWeb, *Body Exterior, Rear Doors*.

## Sunroof Tightening Specifications

Component	Nm
Assembly frame bolts	8
Front and rear glass panel bolt/screws	7
Panel motor screw	3.5
Rear lid screws	2
Sunshade motor screws	3.5
Sunshade screws	3

## Front and Rear Bumper Tightening Specifications

Component	Nm
Bumper carrier bolts <sup>1)</sup>	20
	60
Bumper cover bolt attached to lock carrier screws	8
Front and rear bumper cover screws	3
Wheel trim bolt	2

<sup>1)</sup> For bolt tightening clarification, refer to ElsaWeb, *Body Exterior, Bumpers*.

## Mirror and Roof Rail Tightening Specifications

Component	Nm
Adjusting motor screw	1
Mirror base bolts	9
Roof rail bolts/nuts	10

## Body Interior

### Storage Compartment Covers and Trim Tightening Specifications

Component	Nm
Center armrest screws	2.5
Center console mounting bracket screws	1.5
Grab handle screws	3
Rear center console trim screws	1.5
Steering column trim screws	1.5
Storage compartment screws	1.5
Sun visor screws	3

### Passenger Protection Tightening Specifications

Component	Nm
Airbag control module (J234) nuts	9
Automatic belt retractor nut	50
Belt anchor bolt	50
Belt height adjustment bolt	20
Belt relay bolt	50
Crash sensor bolt	8
Knee airbag bolts	6
Knee airbag bracket bolts	8
Rear side airbag sensor screws	9
Seat belt anchor bolt	50
Seat belt latch bolt	50
Seat belt latch nut	50
Seat belt relay bolt	50
Side airbag bolts	9
Side airbag sensor screws	1
Side curtain cap nuts	9

## Interior Trim Tightening Specifications

Component	Nm
A-pillar trim bolts	2
D-pillar trim bolts	3
Footrest trim bolts	1.5
Front door trim bolts	4.5
Instrument panel cross member bolts <sup>1)</sup>	1.5
	8
	10
	20
Instrument panel cover screws	1.5
Luggage compartment slide support bolts	8
Rear door trim bolts	4.5
Rear door pocket bolt	2
Rear lid trim bolts	1.5
Tie-down bracket bolts	8

<sup>1)</sup> For bolt tightening clarification, refer to ElsaWeb, *Interior Trim, Instrument Panel Crossmember*.

Body

## Seat Frames Tightening Specifications

Component	Nm
Backrest bolts	33 ± 3.0
Drawer bolts	7.5
Front seat bracket bolts	7.5
Front seat frame bolts	50
Manually operated lumbar support	1.5 ± 1.0
Manual seat height adjustment operating lever bolts	8 ± 1.0
Rear center armrest bolts	8
Rear seat backrest bolts	36
Rear seat unit bolts	50 ± 7.5
Seat trim bolts	2
Switch bolts	0.7 ± 0.5

# HEATING AND AIR CONDITIONING

## *General, Technical Data*

### Refrigerant Oil Distribution

Component	Approximate % of total amount of oil in component
A/C compressor	50
Condenser	10
Suction hose	10
Evaporator	20
Fluid reservoir	10

### Refrigerant R134a Vapor Pressure Table

Temperature in °C	Pressure in bar (positive pressure) of R134a
-45	-0.61
-40	-0.49
-35	-0.34
-30	-0.16
-25	0.06
-20	0.32
-15	0.63
-10	1.00
-5	1.43
0	1.92
5	2.49
10	3.13
15	3.90
20	4.70
25	5.63
30	6.70
35	7.83
40	9.10
45	10.54
50	12.11
55	13.83
60	15.72
65	17.79
70	20.05
75	22.52
80	25.21
85	28.14
90	31.34

# Heating, Ventilation

## Fastener Tightening Specification

Component	Nm
Auxiliary air heater heating element ground wire connection	9
Coolant shut-off valve bolt	8 ± 0.9
Coolant shut-off valve nut	6 ± 0.5

# Air Conditioning

## Fastener Tightening Specifications

Component	Nm
Belt tensioner <sup>1) 4)</sup>	25 ± 3
Belt tensioner <sup>1) 5)</sup>	40 ± 3
Bracket cover retaining nuts <sup>1)</sup>	9
Compressor bracket-to-block <sup>1)</sup>	40 ± 3
Compressor-to-bracket <sup>1) 2)</sup>	25 ± 3
Compressor to bracket <sup>3)</sup> (M10 x 100)	45 ± 3
Condenser fittings	12 ± 1.5
Coolant pipe bolts <sup>1)</sup>	9
Drier cartridge cover	12 ± 2
Expansion valve	10 ± 1
High pressure sensor	8 ± 1
Indirect ventilation door motors	1.5
Refrigerant lines-to-A/C compressor	20 ± 3

<sup>1)</sup> TDI

<sup>2)</sup> 3.6L

<sup>3)</sup> Hybrid

<sup>4)</sup> For bolt tightening clarification, refer to ElsaWeb, *A/C Compressor*, item 15.

<sup>5)</sup> For bolt tightening clarification, refer to ElsaWeb, *A/C Compressor*, item 16.

# ELECTRICAL SYSTEM

## *Electrical Equipment*

### Battery, Starter, Generator, Cruise Control Tightening Specifications

Component	Fastener size	Nm
Battery cap nut	-	20
Battery terminal	-	6
Battery interrupt igniter	-	20
Battery hold-down (lower) bolt	-	10
Battery retainer (upper) bolt	-	9
Jump start point B+ wire	-	20
Jump start point cable	-	4
Jump start terminal housing bracket	-	9
<b>3.6L</b>		
B+ wire-to-generator	M8	15
B+ wire-to-starter solenoid switch nut	M8	15
Belt tensioner bolts	M8 x 30	20
Generator collar bolts	M8 x 90	20
Starter collar bolts	M12 x 60	75
<b>TDI</b>		
B+ wire-to-generator	-	20
B+ wire-to-starter solenoid switch nut	M8	20
Generator bolt	M8 x 90	22
Ground cable-to-starter bolt	M8	20
Idler pulley bracket hex head combination bolt	M10 x 35	40
Idler pulley, bolt	M8 x 25	23
Lower starter bolt	M8	22
Lower starter bolt without 16 mm open ring spanner -T10388-	-	65
Ribbed belt pulley	-	25 plus an additional 60° ( $\frac{1}{6}$ turn)
Upper starter bolt	M10	42
Upper starter bolt without -T10388-	-	65
Upper starter bolt with 16 mm open ring spanner T10388 & Torque wrench VAS 5820	-	50
Upper starter bolt with T10388 & Torque wrench V.A.G 1332/	-	53
Voltage regulator	-	4

## Windshield Wiper/Washer Tightening Specifications

Component	Fastener size	Nm
Crank-to-windshield wiper motor shaft hex flange bolt	M8	25
Front wiper arm shaft nut	M10	32
Rear wiper arm shaft nut		12
Spray jet telescopic cylinder		2
Window and headlamp washer tank-to-body	M6 x 16	6
Windshield wiper frame with linkage-to-body combi-bolt	M6 x 35	9
Wiper motor-to-wiper frame bolts	M6 x 19	9
Wiper motor nuts-to-rear lid		8

## Exterior Lights, Switches Tightening Specifications

Component	Nm
Access/start authorization antennas	2
Access/start authorization switch	1.5
Cornering lamp and headlamp range control module	2
Fog lamp bolt	2
Gateway control module bracket	3.5
Headlamp housing screws	5
Headlamp repair mounting tab	1
Parking aid control module-to-gateway control module bracket	1.5
Side panel tail lamps-to-body	2
Steering column clamping ring	4
Steering column electronic systems control module	0.5
Tail lamp assembly-to-rear lid	3

## Interior Lights, Switches Tightening Specifications

Component	Nm
Alarm horn bracket	4
Front interior lamp	2
Horn bracket	20
Power steering column switch	1.5

## Wiring Tightening Specifications

Component	Nm
Comfort system central control module bracket	3.5
Connection/conjunction box 2	2.5
Connection/conjunction box 3	8
Relay and fuse carrier 2	10

# DTC CHART

## Engine Code - CNRB

### Fuel and Air Mixture, Additional Emissions Regulations

DTC	Error Message	Malfunction Criteria and Threshold Value
P00AF	Turbocharger Boost Control Module Performance	Control deviation > 8% and actual position > 30%
P00C6	Fuel Rail Pressure Too Low - Engine Cranking	Fuel rail high pressure value < 12000 - 23000 kPa
P0045	Turbocharger Boost Control Solenoid Circuit Open	Diagnostic signal from power stage > 0.8 V (Out 1) and < 2 V (Out 2)
P0047	Turbocharger Boost Control Solenoid Circuit Low	Diagnostic signal from power stage = 8 - 18 A
P0048	Turbocharger Boost Control Solenoid Circuit High	Diagnostic signal from power stage = 8 - 18 A
P0071	Ambient Air Temperature Sensor Circuit Range/ Performance	<ul style="list-style-type: none"> <li>• Temperature difference to ECT, ECT 2 &gt; 40 °K</li> <li>• Temperature difference to T2, and FTS &gt; 45 °K</li> <li>• Error bit = set</li> </ul>
P0072	Ambient Air Temperature Sensor Circuit Low	AAT signal short to ground
P0073	Ambient Air Temperature Sensor Circuit High	AAT signal short to battery
P0087	Fuel Rail/System Pressure - Too Low	<ul style="list-style-type: none"> <li>• Control deviation &lt; -20,000 to -30,000 kPa</li> <li>• Pressure &gt; 215,000 kPa</li> </ul>
P0088	Fuel Rail/System Pressure - Too High	Fuel rail pressure > 13.9 MPa
P0090	Fuel Pressure Regulator 1 Control Circuit	Diagnostic signal from power stage > 4.5 V
P0091	Fuel Pressure Regulator 1 Control Circuit Low	Diagnostic signal from power stage < 2.97 V
P0092	Fuel Pressure Regulator 1 Control Circuit High	Diagnostic signal from power stage > 2.2 A
P0101	Mass Air Flow Circuit Range/ Performance	Ratio of modeled and measured air mass flow > 1.15 or < 0.85



DTC	Error Message	Malfunction Criteria and Threshold Value
P0102	Mass Air Flow Circuit Low Input	MAF sensor signal (< 0.083 mSec.) > 900 kg/hr
P0103	Mass Air Flow Circuit High Input	MAF sensor signal (> 4.5 mSec.) ≤ 0 kg/hr
P0104	Mass Air Flow Circuit Intermittent	AF sensor signal period = not measurable
P0111	Intake Air Temperature Circuit Performance	<ul style="list-style-type: none"> <li>• Temperature difference to ECT, ECT 2 &gt; 35 °K</li> <li>• Temperature difference to FTS &gt; 40 °K</li> <li>• Temperature difference to T1 &gt; 45 °K</li> </ul>
P0112	Intake Air Temperature Sensor Circuit Low Input	Signal voltage < 162 mV
P0113	Intake Air Temperature Sensor Circuit High Input	Signal voltage > 3255 mV
P0116	Engine Coolant Temperature Sensor 1 Circuit Range/Performance	<ul style="list-style-type: none"> <li>• ECT increase &lt; f(ECT @ start) °K</li> <li>and</li> <li>• Engine running time &gt; f(ECT @ start) Sec</li> <li>or</li> <li>• Temperature difference to ECT 2 &gt; 30 °K</li> <li>• Temperature difference to T2, FTS &gt; 35 °K</li> <li>• Temperature difference to T1 &gt; 40 °K</li> </ul>
P0117	Engine Coolant Temperature Sensor 1 Circuit Low	Signal voltage < 162 mV
P0118	Engine Coolant Temperature Sensor 1 Circuit High	Signal voltage > 3255 mV
P0121	Throttle/Pedal Position Sensor A Circuit Range/Performance	Position sensor signal > 1 V or 0.15 to 0.30 V
P0122	Throttle/Pedal Position Sensor A Circuit Low Input	Position sensor signal < 0.15 V
P0123	Throttle/Pedal Position Sensor A Circuit High Input	Position sensor signal ≥ 4.85 V
P0128	Coolant Thermostat (Coolant Temperature Below Thermostat Regulating Temperature)	Measured temperature < 66 °C while modeled temperature > 78 °C

DTC	Error Message	Malfunction Criteria and Threshold Value
P0130	O2 Sensor Circuit (Bank 1, Sensor 1) Malfunction	O2S ceramic temperature < 640°C
		Virtual mass > 3.0 V
		Nernst voltage > 4.0 V
		Adjustment voltage > 6 V
		or
		Virtual mass < 2 V
		Nernst voltage < 1.75 V
		Adjustment voltage < 0.9 V
P0132	O2 Sensor Circuit (Bank 1 Sensor 1) High Voltage	O2 signal > 3.2 V
P0133	O2 Circuit (Bank 1, Sensor 1) Slow Response	<ul style="list-style-type: none"> <li>• Oxygen 30 - 70% time &gt; 5 Sec</li> <li>• Time to reach 60% oxygen &gt; 5 Sec.</li> </ul>
P0134	O2 Sensor Circuit Bank 1 Sensor 1 No Activity Detected	<ul style="list-style-type: none"> <li>• Integrated oxygen sensor temperature &gt; 280000 - 917476 Kelvin</li> <li>• Oxygen sensor heating not active</li> </ul>
P0135	O2 Sensor Heater Circuit (Bank 1 Sensor 1) Malfunction	<ul style="list-style-type: none"> <li>• Sensor element temperature &lt; 720 or &gt; 840 °C</li> <li>• Power stage active and signal current = -100 to 10000 uA</li> <li>• Power stage not active and signal current = -1000 to -350 uA</li> <li>• Power stage not active and signal current = -100 to 100 uA</li> </ul>
P016A	Excessive Time To Enter Closed Loop Air/Fuel Ratio Control	Control intervention 0%
P0171	Fuel Trim (Bank 1) System Too Lean	Difference between measured vs. modeled injection quantity > 5 - 20 mg/stroke
P0172	Fuel Trim (Bank 1) System too Rich	Difference between measured vs. modeled injection quantity < 5 - 20 mg/stroke

DTC	Error Message	Malfunction Criteria and Threshold Value
P0181	Fuel Temperature Sensor Circuit Range/Performance	<ul style="list-style-type: none"> <li>• Temperature difference to ECT, ECT 2 &gt; 35 °K</li> <li>• Temperature difference to FTS &gt; 40 °K</li> <li>• Temperature difference to T1 &gt; 45 °K</li> </ul>
P0182	Fuel Temperature Sensor Circuit Low	Signal voltage < 100 mV
P0183	Fuel Temperature Sensor Circuit High	Fuel temperature sensor voltage > 4.90 V
P0191	Fuel Rail Pressure Sensor Circuit Range/Performance	<ul style="list-style-type: none"> <li>• Signal voltage &lt; 428 mV or &gt; 613 mV</li> <li>• Adaptation of FRPR &lt; 70% or &gt; 130%</li> </ul>
P0192	Fuel Rail Pressure Sensor A Circuit Low Input	Signal voltage < 0.2 V
P0193	Fuel Rail Pressure Sensor Circuit High Input	Signal voltage > 4.8 V
P01BA	Engine Oil Temperature Sensor 2 Performance	<ul style="list-style-type: none"> <li>• EOT cross checks for fault detection: ≥ 6 detected faults</li> <li>• EOT vs. ECT 3, IAT, FTS, AAT or ECT 2 &gt; 30 Kelvin</li> </ul>
P01BB	Engine Oil Temperature Sensor 2 Circuit Low	Signal voltage < 0.20 V for ≥ 5 s
P01BC	Engine Oil Temperature Sensor 2 Circuit High	Signal voltage > 4.85 V for ≥ 5 Sec.
P01BD	Engine Oil Temperature Sensor 2 Circuit Intermittent / Erratic	<ul style="list-style-type: none"> <li>• Oil temperature increase &amp;lt; 3.0 K</li> <li>• Oil temperature &lt; 66 °C</li> <li>• Evaluation timer &gt; 59 - 251 s</li> </ul>
P01E3	Engine Temperature Control Sensor Circuit	Signal voltage > 4.92 V
P01E4	Engine Temperature Control Sensor Circuit Range/ Performance	ETC vs IAT or AAT or FTS at start up > 35 Kelvin
P01E5	Engine Temperature Control Sensor 3 Circuit Low	Signal voltage < 0.22 V

DTC	Error Message	Malfunction Criteria and Threshold Value
P0201	Cylinder 1 Injector Circuit	<ul style="list-style-type: none"> <li>• Signal from power stage &gt; 60 V</li> <li>• Voltage level &lt; 30 V</li> <li>• Injector voltage after charging &lt; 70% nominal voltage</li> <li>• Injector voltage before charging &lt; 50% nominal voltage</li> </ul>
P0202	Cylinder 2 Injector Circuit	<ul style="list-style-type: none"> <li>• Signal from power stage &gt; 60 V</li> <li>• Voltage level &lt; 30 V</li> <li>• Injector voltage after charging &lt; 70% nominal voltage</li> <li>• Injector voltage before charging &lt; 50% nominal voltage</li> </ul>
P0203	Cylinder 3 Injector Circuit	<ul style="list-style-type: none"> <li>• Signal from power stage &gt; 60 V</li> <li>• Voltage level &lt; 30 V</li> <li>• Injector voltage after charging &lt; 70% nominal voltage</li> <li>• Injector voltage before charging &lt; 50% nominal voltage</li> </ul>
P0204	Cylinder 4 Injector Circuit	<ul style="list-style-type: none"> <li>• Signal from power stage &gt; 60 V</li> <li>• Voltage level &lt; 30 V</li> <li>• Injector voltage after charging &lt; 70% nominal voltage</li> <li>• Injector voltage before charging &lt; 50% nominal voltage</li> </ul>
P0205	Cylinder 4 Injector Circuit	<ul style="list-style-type: none"> <li>• Signal from power stage &gt; 60 V</li> <li>• Voltage level &lt; 30 V</li> <li>• Injector voltage after charging &lt; 70% nominal voltage</li> <li>• Injector voltage before charging &lt; 50% nominal voltage</li> </ul>

DTC	Error Message	Malfunction Criteria and Threshold Value
P0206	Cylinder 4 Injector Circuit	<ul style="list-style-type: none"> <li>• Signal from power stage &gt; 60 V</li> <li>• Voltage level &lt; 30 V</li> <li>• Injector voltage after charging &lt; 70% nominal voltage</li> <li>• Injector voltage before charging &lt; 50% nominal voltage</li> </ul>
P0234	Turbo Charger Overboost Condition Limit Exceeded	Control deviation < -22 kPa
P0236	Turbocharger Boost Sensor A Circuit Range/Performance	Absolute value of pressure difference > 14 kPa
P0237	Turbocharger Boost Sensor A Circuit Low Input	Sensor voltage < 0.40 V
P0238	Turbocharger Boost Sensor A Circuit High Input	Signal voltage > 4.90 V
P026A	Charge Air Cooler Below Efficiency	Filtered charge air cooler efficiency < 7
P0263	Cylinder 1 Contribution/Balance	<ul style="list-style-type: none"> <li>• Injection time with no torque &gt; 0.23 - 0.43 mSec. or &lt; 0.14 - 0.16 mSec.</li> <li>• Diagnostic signal from power stage = internal signal</li> </ul>
P0266	Cylinder 2 Contribution/Balance	<ul style="list-style-type: none"> <li>• Injection time with no torque &gt; 0.23 - 0.43 mSec. or &lt; 0.14 - 0.16 mSec.</li> <li>• Diagnostic signal from power stage = internal signa</li> </ul>
P0269	Cylinder 3 Contribution/Balance	<ul style="list-style-type: none"> <li>• Injection time with no torque &gt; 0.23 - 0.43 mSec. or &lt; 0.14 - 0.16 mSec.</li> <li>• Diagnostic signal from power stage = internal signa</li> </ul>
P0272	Cylinder 4 Contribution/Balance	<ul style="list-style-type: none"> <li>• Injection time with no torque &gt; 0.23 - 0.43 mSec. or &lt; 0.14 - 0.16 mSec.</li> <li>• Diagnostic signal from power stage = internal signa</li> </ul>
P0275	Cylinder 5 Contribution/Balance	<ul style="list-style-type: none"> <li>• Injection time with no torque &gt; 0.23 - 0.43 mSec. or &lt; 0.14 - 0.16 mSec.</li> <li>• Diagnostic signal from power stage = internal signa</li> </ul>

<b>DTC</b>	<b>Error Message</b>	<b>Malfunction Criteria and Threshold Value</b>
P0278	Cylinder 6 Contribution/ Balance	<ul style="list-style-type: none"> <li>• Injection time with no torque &gt; 0.23 - 0.43 mSec. or &lt; 0.14 - 0.16 mSec.</li> <li>• Diagnostic signal from power stage = internal signa</li> </ul>
P0299	Turbo Charger Underboost	Control deviation > 30 - 100 kPa with f (engine coolant temp)
P20A0	Reducing Agent Purge Control Valve Circuit Open	Diagnostic signal from power stage > 4.5 V
P20A2	Reducing Agent Purge Control Valve Circuit Low	Diagnostic signal from power stage < 2.97 V
P20A3	Reducing Agent Purge Control Valve Circuit High	Diagnostic signal from power stage > 2.2 A
P20A5	Reducing Agent Purge Control Valve Stuck Closed	Difference between pressure at start of pressure reduction and current pressure > 0.00 kPa
P20BB	Reducing Agent Heater 1 Control Circuit Low	Diagnostic signal from power stage < 2.97 V
P20BC	Reducing Agent Heater 1 Control Circuit High	Diagnostic signal from power stage > 2.2 A
P20BD	Reducing Agent Heater 2 Control Circuit/Open	Diagnostic signal from power stage > 4.5 V
P20BF	Reducing Agent Heater 2 Control Circuit Low	Signal voltage < 2.97 V
P20B5	Reducing Agent Metering Unit Heater Control Circuit/Open	Current during heating < 2 A
P20B7	Reducing Agent Metering Unit Heater Control Circuit Low	Max. power at engagement < 5 A
P20B8	Reducing Agent Metering Unit Heater Control Circuit High	Conductance > 0.521 Sec.
P20B9	Reducing Agent Heater 1 Control Circuit/Open	Diagnostic signal from power stage > 4.5 V
P20C0	Reducing Agent Heater 2 Control Circuit High	Diagnostic signal from power stage > 2.2 A
P20EE	SCR NOx Catalyst Efficiency Below Threshold Bank 1	Difference between calculated and measured efficiency > 0.3

DTC	Error Message	Malfunction Criteria and Threshold Value
P20E8	Reducing Agent Pressure Too Low	<ul style="list-style-type: none"> <li>• Pressure built up for 45 attempts &lt; 3500 hPa</li> </ul> or <ul style="list-style-type: none"> <li>• Actual pressure &lt; 3000 hPa or Target - Actual pressure &gt; 1500 hPa</li> </ul>
P20E9	Reducing Agent Pressure Too High	<ul style="list-style-type: none"> <li>• Pressure at dosing end &gt; 500 hPa after 10 Sec.</li> </ul> or <ul style="list-style-type: none"> <li>• Actual pressure &gt; 7900 hPa or Target - Actual pressure &lt; -1500 hPa</li> </ul>
P20F4	Reducing Agent Consumption Too Low	SCR adaptive value $\geq 1.79$
P20F5	Reducing Agent Consumption Too High	SCR adaptive value $\leq 0.51$
P2002	Particulate Trap Bank 1 Efficiency Below Threshold	<ul style="list-style-type: none"> <li>• Differential pressure &lt; f (volumetric flow rate, soot load)</li> </ul> or <ul style="list-style-type: none"> <li>• Differential pressure &lt; f (volumetric flow rate)</li> </ul>
P2004	Intake Manifold Runner Control (Bank 1) Stuck Open	<ul style="list-style-type: none"> <li>• Control deviation &gt; 10%</li> <li>• Actual position <math>\leq 40\%V</math></li> </ul>
P2005	Intake Manifold Runner Control (Bank 2) Stuck Open	<ul style="list-style-type: none"> <li>• Control deviation &gt; 10%</li> <li>• Actual position <math>\leq 40\%V</math></li> </ul>
P2006	Intake Manifold Runner Control (Bank 1) Stuck Closed	<ul style="list-style-type: none"> <li>• Control deviation &gt; 10%</li> <li>• Actual position <math>\leq 40\%V</math></li> </ul>
P2007	Intake Manifold Runner Control Bank 2 Stuck Closed	<ul style="list-style-type: none"> <li>• Control deviation &gt; 10%</li> <li>• Actual position <math>\leq 40\%V</math></li> </ul>
P2008	Intake Manifold Runner (Bank 1) Control Circuit/Open	<ul style="list-style-type: none"> <li>• Diagnostic signal from power stage &gt; 0.8 V (output 1) and &lt; 2 V (output 2)</li> </ul> or <ul style="list-style-type: none"> <li>• Diagnostic signal from power stage = 8 to 18 A</li> </ul> or <ul style="list-style-type: none"> <li>• Diagnostic signal from power stage &gt; 5 V or &lt; 3.4 V</li> </ul>
P2009	Intake Manifold Runner (Bank 1) Control Circuit Low	Diagnostic signal from power stage 8 to 18 A
P2010	Intake Manifold Runner Control Circuit High (Bank 1)	Diagnostic signal from power stage = 8 to 18 A

<b>DTC</b>	<b>Error Message</b>	<b>Malfunction Criteria and Threshold Value</b>
P2011	Intake Manifold Runner (Bank 2) Control Circuit Stuck Open	<ul style="list-style-type: none"> <li>• Diagnostic signal from power stage &gt; 0.8 V (output 1) and &lt; 2 V (output 2)</li> <li>or</li> <li>• Diagnostic signal from power stage = 8 to 18 A</li> <li>or</li> <li>• Diagnostic signal from power stage &gt; 5 V or &lt; 3.4 V</li> </ul>
P2012	Intake Manifold Runner Bank 2 Control Circuit Low	Diagnostic signal from power stage 8 to 18 A
P2013	Intake Manifold Runner Bank 2 Control Circuit High	Diagnostic signal from power stage = 8 to 18 A
P2014	Intake Manifold Runner Position Sensor/Switch Circuit (Bank 1)	Signal voltage > 4.75 V
P2015	Intake Manifold Runner Position Sensor/Switch Circuit Range/Performance	<ul style="list-style-type: none"> <li>• Position sensor signal &lt; 3550 mV</li> <li>• Position sensor signal &gt; 1450 mV</li> <li>or</li> <li>• Position sensor signal &gt; 550 mV and &lt; 250 mV</li> <li>or</li> <li>• Position sensor signal &gt; 4450 mV and &lt; 4750 mV</li> </ul>
P2016	Intake Manifold Runner Position Sensor Circuit Low	Position sensor signal $\leq$ 250 mV
P2017	Intake Manifold Runner Position Sensor Circuit High	Position sensor signal $\geq$ 4750 mV
P202A	Reducing Agent Tank Heater Control Circuit/Open	Current during heating < 2 A
P202B	Reducing Agent Tank Heater Control Circuit Low	Maximum power at engagement < 3 W
P202C	Reducing Agent Tank Heater Control Circuit High	Max. power at engagement > 14 W



DTC	Error Message	Malfunction Criteria and Threshold Value
P2020	Intake Manifold Runner Position Sensor Circuit (Bank 2) Range/Performance	<ul style="list-style-type: none"> <li>• Position sensor signal &lt; 3550 mV</li> <li>• Position sensor signal 1450 mV</li> </ul> or <ul style="list-style-type: none"> <li>• Position sensor signal &gt; 550 mV and &lt; 250 mV</li> </ul> or <ul style="list-style-type: none"> <li>• Position sensor signal &gt; 4450 mV and &lt; 4750 mV</li> </ul>
P2021	Intake Manifold Runner Position Sensor Circuit (Bank 2) Low	Position sensor signal $\leq 250$ mV
P2022	Intake Manifold Runner Position Sensor Circuit (Bank 2) High	Position sensor signal $\geq 4750$ mV
P203A	Reducing Agent Level Sensor Circuit	<ul style="list-style-type: none"> <li>• PWM signal &lt; 15%</li> </ul> or <ul style="list-style-type: none"> <li>• PWM signal &gt; 85%</li> </ul>
P203B	Reducing Agent Level Sensor Circuit Range/Performance	<ul style="list-style-type: none"> <li>• PWM signal = 31 - 41%</li> </ul> or <ul style="list-style-type: none"> <li>• PWM signal = 15 - 30%</li> </ul>
P2031	Exhaust Gas Temperature Sensor 2 Circuit	Signal voltage > 1652 mV
P2032	Exhaust Gas Temperature (Sensor 2) Circuit Low	Signal voltage < 330 mV
P204A	Reducing Agent Pressure Sensor Circuit	Signal voltage < 200 mV
P204B	Reducing Agent Pressure Sensor Circuit Range/Performance	Signal voltage > 4800 mV
P204D	Reducing Agent Pressure Sensor Circuit High	Actual pressure before pressure build up > 500 hPa
P2047	Reducing Agent Injection Valve Circuit Open	Diagnostic signal from power stage > 4.5 V
P2048	Reducing Agent Injection Valve Circuit Low	<ul style="list-style-type: none"> <li>• Diagnostic signal from power stage &lt; 2.97 V</li> </ul> or <ul style="list-style-type: none"> <li>• Analog measure &lt; 2.8 V</li> </ul>
P2049	Reducing Agent Injection Valve Circuit High	<ul style="list-style-type: none"> <li>• Diagnostic signal from power stage &gt; 2.2 AV</li> </ul> or <ul style="list-style-type: none"> <li>• Analog measure &lt; 200 mA</li> </ul>

<b>DTC</b>	<b>Error Message</b>	<b>Malfunction Criteria and Threshold Value</b>
P205A	Reducing Agent Tank Temperature Sensor Circuit	Signal voltage > 3100 mV
P205B	Reducing Agent Tank Temperature Sensor Circuit Range/Performance	Absolute value of temperature difference to ECT > 30 °K
P205C	Reducing Agent Tank Temperature Sensor Circuit Low	Signal voltage < 200 mV
P207F	Reducing Agent Quality Performance	0.5 Calculated efficiency
P208A	Reducing Agent Pump Control Circuit/Open	Deviation between actual and nominal control value > 0.75%
P208C	Reducing Agent Pump Control Circuit Low	Diagnostic signal from power stage permanently < .46 uV
P208D	Reducing Agent Pump Control Circuit High	Diagnostic signal from power stage permanently > .6 uV
P208E	Reducing Agent Injection Valve Stuck Closed (Bank 1 Unit 1)	Missing number of signal peaks > 50
P2080	Exhaust Gas Temperature Sensor Circuit Bank 1 Range/ Performance	<ul style="list-style-type: none"> <li>• Temperature difference to temp EGR T3, T4, T5, T6 &gt; 60 °K</li> <li>or</li> <li>• Mean value of modeled to measured T4 &gt; 100 °K</li> </ul>
P2084	Exhaust Gas Temperature Sensor 2 Circuit Range/ Performance	<ul style="list-style-type: none"> <li>• Temperature difference to temp EGR T3, T4, T5, T6 &gt; 60 °K</li> <li>or</li> <li>• Mean value of modeled to measured T3 &gt; 100 °K</li> </ul>

## Ignition System

<b>DTC</b>	<b>Error Message</b>	<b>Malfunction Criteria and Threshold Value</b>
P0300	Random/Multiple Cylinder. Misfire Detected	<ul style="list-style-type: none"> <li>• Rise in engine speed after fuel injection Calculated based on values from last two engine revolutions</li> <li>• Error threshold 82% misfire over 440 crankshaft revolutions</li> </ul>

DTC	Error Message	Malfunction Criteria and Threshold Value
P0301	Cylinder 1 Misfire Detected	<ul style="list-style-type: none"> <li>Emission threshold misfire rate (MR) &gt; 1.7%</li> <li>Catalyst damage misfire rate (MR) &gt; 5.0 - 20.0%</li> </ul>
P0302	Cylinder 2 Misfire Detected	<ul style="list-style-type: none"> <li>Emission threshold misfire rate (MR) &gt; 1.7%</li> <li>Catalyst damage misfire rate (MR) &gt; 5.0 - 20.0%</li> </ul>
P0303	Cylinder 3 Misfire Detected	<ul style="list-style-type: none"> <li>Emission threshold misfire rate (MR) &gt; 1.7%</li> <li>Catalyst damage misfire rate (MR) &gt; 5.0 - 20.0%</li> </ul>
P0304	Cylinder 4 Misfire Detected	<ul style="list-style-type: none"> <li>Emission threshold misfire rate (MR) &gt; 1.7%</li> <li>Catalyst damage misfire rate (MR) &gt; 5.0 - 20.0%</li> </ul>
P0305	Cylinder 5 Misfire Detected	<ul style="list-style-type: none"> <li>Emission threshold misfire rate (MR) &gt; 1.7%</li> <li>Catalyst damage misfire rate (MR) &gt; 5.0 - 20.0%</li> </ul>
P0306	Cylinder 6 Misfire Detected	<ul style="list-style-type: none"> <li>Emission threshold misfire rate (MR) &gt; 1.7%</li> <li>Catalyst damage misfire rate (MR) &gt; 5.0 - 20.0%</li> </ul>
P0321	Ignition/Distributor Engine Speed Input Circuit Range/ Performance	<ul style="list-style-type: none"> <li>Counted teeth vs. reference &gt; 200</li> <li>Monitoring reference gap failure</li> </ul>
P0322	Ignition/Distributor Engine Speed Input Circuit No Signal	<ul style="list-style-type: none"> <li>Camshaft signals &gt; 10</li> <li>Engine speed = no signal</li> </ul>

### Additional Exhaust Regulation

DTC	Error Message	Malfunction Criteria and Threshold Value
P04DD	Cold Start EGR Insufficient Flow Detected	Control deviation < f(engine speed, injection quantity, target air mass flow)
P04DE	Cold Start EGR Excessive Flow Detected	Ratio of modeled and measured air mass flow > f(turbo charger position)

DTC	Error Message	Malfunction Criteria and Threshold Value
P040B	Exhaust Gas Recirculation Temperature Sensor Circuit Range/Performance	<ul style="list-style-type: none"> <li>• Value of modeled and measured temp &gt; f(value of modeled temp EGR)</li> </ul> or <ul style="list-style-type: none"> <li>• Value of modeled and measured temp &gt; f(value of modeled temp EGR)</li> </ul>
P040C	Exhaust Gas Recirculation Temperature Sensor Circuit Low	Signal voltage < 330 mV
P040D	Exhaust Gas Recirculation Temperature Sensor Circuit High	Signal voltage > 1652 mV
P0401	Exhaust Gas Recirculation Insufficient Flow Detected	Control deviation < f (engine speed, injection quantity, target air mass flow)
P0402	Exhaust Gas Recirculation Excessive Flow Detected	Ratio of modeled and measured air mass flow > 1.3
P0403	Exhaust Gas Recirculation Circuit	<ul style="list-style-type: none"> <li>• Diagnostic signal from power stage (Out 1) &gt; 0.8 and 2 V (Out 2)</li> <li>• Diagnostic signal from power stage = 8 - 18 A</li> <li>• Diagnostic signal from power stage &gt; 5 or &lt; 3.4 V</li> <li>• Control deviation &gt; 10%</li> <li>• Actual position &gt; 17%</li> </ul>
P0404	Exhaust Gas Recirculation Control Circuit Range/Performance	<ul style="list-style-type: none"> <li>• Control deviation &gt; 10%</li> <li>• Actual position &gt; 17%</li> </ul>
P0405	Exhaust Gas Recirculation Sensor Circuit Low	Position sensor signal < 210 mV
P0406	Exhaust Gas Recirculation Sensor Circuit High	Position sensor signal $\geq$ 4690 mV
P0420	Catalyst System (Bank 1) Efficiency Below Threshold	Ratio of measured and modeled heat < 0.3
P046C	Exhaust Gas Recirculation Sensor Circuit Range/Performance	Position sensor signal > 4310 and < 4690 mV

## Speed and Idle Control

DTC	Error Message	Malfunction Criteria and Threshold Value
P050A	Cold Start Idle Air Control System Performance	Idle speed control deviation more than 10% under or 10% above desired idle speed
P050E	Cold Start Engine Exhaust Temperature Too Low	Exhaust gas temperature < 100 °C
P0501	Vehicle Speed Sensor A Range/Performance	Vehicle speed < 4 km/h
P0502	Vehicle Speed Sensor Circuit Low	Sensor signal failure
P0506	Idle Air Control System - RPM Lower Than Expected	Control deviation < 10%
P0507	Idle Air Control System - RPM Higher Than Expected	Control deviation > 10%
P052F	Glow Plug Control Module System Voltage	Error message from Glow Control Unit.
P054E	Idle Control System Fuel Quantity Lower Than Expected	Fuel quantity < 0.004 g/rev
P054F	Idle Control System Fuel Quantity Higher Than Expected	Fuel quantity > 0.0182 to 0.0325 g/rev
P0544	Exhaust Gas Temperature Sensor Circuit (Bank 1)	Signal voltage < 330 mV
P0545	Exhaust Gas Temperature Sensor Circuit (Bank 1) Low	Signal voltage > 1652 mV

## Control Module and Output Signals

DTC	Error Message	Malfunction Criteria and Threshold Value
P06BA	Cylinder 2 Glow Plug Circuit Range/Performance	<ul style="list-style-type: none"> <li>• Glow plug resistance (between 4 - 9 Sec.) &lt; 0.3 ohm</li> <li>• Glow plug resistance (between 9 - 14 Sec.) &lt; 0.4 ohm</li> <li>• Glow plug resistance (after 14 Sec.) &lt; 0.5 ohm</li> <li>• Glow plug resistance anytime &gt; 1.2 ohm</li> </ul>

DTC	Error Message	Malfunction Criteria and Threshold Value
P06BB	Cylinder 3 Glow Plug Circuit Range/Performance	<ul style="list-style-type: none"> <li>• Glow plug resistance (between 4 - 9 Sec.) &lt; 0.3 ohm</li> <li>• Glow plug resistance (between 9 - 14 Sec.) &lt; 0.4 ohm</li> <li>• Glow plug resistance (after 14 Sec.) &lt; 0.5 ohm</li> <li>• Glow plug resistance anytime &gt; 1.2 ohm</li> </ul>
P06BC	Cylinder 4 Glow Plug Circuit Range/Performance	<ul style="list-style-type: none"> <li>• Glow plug resistance (between 4 - 9 Sec.) &lt; 0.3 ohm</li> <li>• Glow plug resistance (between 9 - 14 Sec.) &lt; 0.4 ohm</li> <li>• Glow plug resistance (after 14 Sec.) &lt; 0.5 ohm</li> <li>• Glow plug resistance anytime &gt; 1.2 ohm</li> </ul>
P06BD	Cylinder 5 Glow Plug Circuit Range/Performance	<ul style="list-style-type: none"> <li>• Glow plug resistance (between 4 - 9 Sec.) &lt; 0.3 ohm</li> <li>• Glow plug resistance (between 9 - 14 Sec.) &lt; 0.4 ohm</li> <li>• Glow plug resistance (after 14 Sec.) &lt; 0.5 ohm</li> <li>• Glow plug resistance anytime &gt; 1.2 ohm</li> </ul>
P06BE	Cylinder 6 Glow Plug Circuit Range/Performance	<ul style="list-style-type: none"> <li>• Glow plug resistance (between 4 - 9 Sec.) &lt; 0.3 ohm</li> <li>• Glow plug resistance (between 9 - 14 Sec.) &lt; 0.4 ohm</li> <li>• Glow plug resistance (after 14 Sec.) &lt; 0.5 ohm</li> <li>• Glow plug resistance anytime &gt; 1.2 ohm</li> </ul>
P06B9	Cylinder 1 Glow Plug Circuit Range/Performance	<ul style="list-style-type: none"> <li>• Glow plug resistance (between 4 - 9 Sec.) &lt; 0.3 ohm</li> <li>• Glow plug resistance (between 9 - 14 Sec.) &lt; 0.4 ohm</li> <li>• Glow plug resistance (after 14 Sec.) &lt; 0.5 ohm</li> <li>• Glow plug resistance anytime &gt; 1.2 ohm</li> </ul>
P06CA	Cylinder 6 Glow Plug Incorrect	Internal resistance < 0.11 and > 1.15 Ω
P06C5	Cylinder 1 Glow Plug Incorrect	Internal resistance < 0.11 and > 1.15 Ω

DTC	Error Message	Malfunction Criteria and Threshold Value
P06C6	Cylinder 2 Glow Plug Incorrect	Internal resistance < 0.11 and > 1.15 $\Omega$
P06C7	Cylinder 3 Glow Plug Incorrect	Internal resistance < 0.11 and > 1.15 $\Omega$
P06C8	Cylinder 4 Glow Plug Incorrect	Internal resistance < 0.11 and > 1.15 $\Omega$
P06C9	Cylinder 5 Glow Plug Incorrect	Internal resistance < 0.11 and > 1.15 $\Omega$
P06E5	Glow Plug Control Module 1 Performance	Calculated ground offset $\geq 1.75$ V or $\leq -1.75$
P06FE	Cold Start Diesel Intake Air Flow Control Performance	Signal low
P0604	Internal Control Module Random Access Memory (RAM) Error	Read/write error bit set
P0605	Internal Control Module Read Only Memory (ROM) Error	Internal self test failed
P0606	Internal Control Module Memory Check Sum Error	<ul style="list-style-type: none"> <li>• ECM internal self test failed</li> <li>• RAM error in memory</li> </ul>
P0607	Control Module Performance	<ul style="list-style-type: none"> <li>• Oxygen sensor adaptation &gt; 0.2 V or &lt; -0.2 V</li> <li>• Internal communication failed or</li> <li>• Sensor voltage &lt; 0.265 V or &gt; 3.9 V</li> </ul>
P0634	ECM Internal Temperature Too High	Current Over-Temperature diagnostic signal from output driver
P0638	Throttle Actuator Control (Bank 1) Range/Performance	Diagnostic signal = low state
P064C	Glow Plug Control Module	Received incorrect number of cylinders or glow plug type is unequal to ECU application = error bit
P0641	Sensor Reference Voltage A Circuit/Open	Voltage supply < 4.7 V or > 5.3 V
P0651	Sensor Reference Voltage B Circuit/Open	Voltage supply < 4.7 V or > 5.3 V
P066A	Cylinder 1 Glow Plug Control Circuit Low	Glow current $\geq 70$ A

<b>DTC</b>	<b>Error Message</b>	<b>Malfunction Criteria and Threshold Value</b>
P066B	Cylinder 1 Glow Plug Control Circuit High	Message from glow plug control module incorrect
P066C	Cylinder 2 Glow Plug Control Circuit Low	Glow current $\geq 70$ A
P066D	Cylinder 2 Glow Plug Control Circuit High	Message from glow plug control module incorrect
P066E	Cylinder 3 Glow Plug Control Circuit Low	Glow current $\geq 70$ A
P066F	Cylinder 3 Glow Plug Control Circuit High	Message from glow plug control module incorrect
P067A	Cylinder 4 Glow Plug Control Circuit Low	Glow current $\geq 70$ A
P067B	Cylinder 4 Glow Plug Control Circuit High	Message from glow plug control module incorrect
P067C	Cylinder 5 Glow Plug Control Circuit Low	Glow current $\geq 70$ A
P067D	Cylinder 5 Glow Plug Control Circuit High	Message from glow plug control module incorrect
P067E	Cylinder 6 Glow Plug Control Circuit Low	Glow current $\geq 70$ A
P067F	Cylinder 6 Glow Plug Control Circuit High	Message from glow plug control module incorrect
P0671	Cylinder 1 Glow Plug Circuit	Glow current $\leq 2.20$ A
P0672	Cylinder 2 Glow Plug Circuit	Glow current $\leq 2.20$ A
P0673	Cylinder 3 Glow Plug Circuit	Glow current $\leq 2.20$ A
P0674	Cylinder 4 Glow Plug Circuit	Glow current $\leq 2.20$ A
P0675	Cylinder 5 Glow Plug Circuit	Glow current $\leq 2.20$ A
P0676	Cylinder 6 Glow Plug Circuit	Glow current $\leq 2.20$ A
P0683	Glow Plug Control Module 1 to PCM Communication Circuit	LIN message no feedback
P0697	Sensor Reference Voltage C Circuit/Open	Voltage supply $< 4.7$ V or $> 5.3$ V
U0001	High Speed CAN Communication Bus	CAN message, no feedback
U0002	High Speed CAN Communication Bus Performance	Global time out. Receiving no messages.
U0028	Vehicle Communication Bus A	CAN message = no feedback



<b>DTC</b>	<b>Error Message</b>	<b>Malfunction Criteria and Threshold Value</b>
U0029	Vehicle Communication Bus A Performance	Global time out. Receiving no messages.
U0101	Lost Communication with TCM	No TCM messages received.
U0106	Lost Communication with Glow Plug Control Module	No message received
U0121	Lost Communication with Anti-Lock Brake System (ABS) Control Module	CAN communication with ABS, time out
U0140	Lost Communication with Body Control Module	No CAN messages from BCM
U0146	Lost Communication With Gateway "A"	CAN messages from Gateway = no message.
U0155	Lost Communication With Instrument Panel Cluster (IPC) Control Module	No CAN messages received from Instrument cluster
U02A3	Lost Communication With PM Sensor	No CAN message received
U0302	Software Incompatibility with Transmission Control Module	Auto trans messages received from ECM
U0307	Software Incompatibility with Glow Plug Control Module	Error bit = set
U04A4	Invalid Data Received From PM Sensor	Communication PM sensor control unit failed > 600 mSec.
U0402	Invalid Data Received From Transmission Control Module	Wrong TCM messages received.
U0407	Invalid Data Received From Glow Plug Control Module	Implausible messages received
U0415	Invalid Data Received From Anti-Lock Brake System Control Module	<ul style="list-style-type: none"> <li>• Error bit = set</li> <li>• Implausible data from ABS or</li> <li>• Speed sensor signal = 655.35 km/h</li> </ul>
U0423	Invalid Data Received From Instrument Panel Cluster Control Module	Error message sent from instrument cluster = invalid data
U0447	Invalid Data Received From Gateway "A"	Implausible message from gateway
U1006	NOx Sensor 1 (Bank 1) No communication	No messages from NOx sensor 1 module
U1024	Communications Bus Fault	Error bit set

<b>DTC</b>	<b>Error Message</b>	<b>Malfunction Criteria and Threshold Value</b>
U1034	NOx Sensor 1 (Bank 1) Implausible Signal	Data from NOx sensor 1 module implausible
U10C1	NOx Sensor 1 (Bank 2) Implausible Signal	Data from NOx sensor 2 module implausible
U10C2	NOx Sensor 1 Bank 2 No Communication	No messages from NOx sensor 2 module

### **Fuel and Air Ratios Control Module**

<b>DTC</b>	<b>Error Message</b>	<b>Malfunction Criteria and Threshold Value</b>
P1419	Exhaust Gas Recirculation Cooler Switch-over Valve 2 Short circuit to Voltage	Diagnostic signal from power stage > 1.5 A
P146D	Heater 1 for Reducing Agent Short Circuit to Voltage	Signal voltage > 3270 mV
P146F	Heater 2 for Reducing Agent Short Circuit to Voltage	Signal voltage > 2900 mV
P148F	Exhaust Gas Recirculation Cooler Switch-Over Valve 2 Electrical malfunction	Diagnostic signal from power stage < 2.97 V
P1499	Exhaust Gas Recirculation Cooler Switch-Over Valve 2 Open Circuit/Short Circuit to Ground	Diagnostic signal from power stage > 4.5 V
P150A	Engine Off Time Performance	ECM time - IPC time > 12 Sec.
P2100	Throttle Actuator Control Motor Circuit/Open	Signal from power stage > 3.26 V and < 5.40 V
P2101	Throttle Actuator A Control Motor Circuit Range/ Performance	Signal = no change
P2102	Throttle Actuator Control Motor Circuit Low	Signal from power stage ≤ 3.26 V
P2103	Throttle Actuator Control Motor Circuit High	Signal from power stage > 1.50 V and > 50 mA
P2111	Throttle Actuator Control System - Stuck Open	<ul style="list-style-type: none"> <li>• Control deviation &gt; 10% or &lt; -10%</li> <li>• Actual position ≤ 30%</li> </ul>
P2112	Throttle Actuator Control System - Stuck Closed	<ul style="list-style-type: none"> <li>• Control deviation &gt; 10% or &lt; -10%</li> <li>• Actual position &gt; 30%</li> </ul>

DTC	Error Message	Malfunction Criteria and Threshold Value
P2122	Throttle/Pedal Position Sensor/Switch D Circuit Low Input	Signal voltage < 0.646 V
P2123	Throttle/Pedal Position Sensor/Switch D Circuit High Input	Signal voltage > 4.889 V
P2127	Throttle/Pedal Position Sensor/Switch E Circuit Low Input	Signal voltage < 0.276 V
P2128	Throttle/Pedal Position Sensor/Switch E Circuit High Input	Signal voltage > 2.644 V
P2138	Throttle/Pedal Position Sensor/Switch D/E Voltage Correlation	Signal voltage sensor 1 vs. sensor 2 > 143 - 260 mV
P2146	Fuel Injector Group A Supply Voltage Circuit/Open	Diagnostic signal from power stage = internal signal
P2149/ P2152	Fuel Injector Group C Supply Voltage Circuit/Open	Diagnostic signal from power stage = internal signal
P2181	Cooling System Performance	Deviation between target and measured ECT < -7.5 Kelvin
P2183	Engine Coolant Temperature Sensor 2 Circuit Range/ Performance	ECT 2 at radiator outlet vs IAT or AAT or FTS at start up > 35 Kelvin
P2184	Engine Coolant Temperature Sensor 2 Circuit Low	Signal voltage < 162 mV
P2195	O2 Sensor Signal Stuck Lean (Bank 1, Sensor 1)	<ul style="list-style-type: none"> <li>• Measured oxygen concentration @ fuel cutoff &gt; 25.6%</li> <li>or</li> <li>• Measured oxygen concentration @ part load &gt; (calculated) 6.5%</li> </ul>
P2196	O2 Sensor Signal Stuck Rich (Bank 1, Sensor 1)	Measured oxygen concentration @ fuel cutoff > 14.7%
P22A0	NOx Sensor (Bank 1 Sensor 2) Circuit Low	NOx value < -105 ppm
P22A1	NOx Sensor (Bank 1 Sensor 2) Circuit High	NOx value > 1655 ppm
P22A7	NOx Sensor (Bank 1 Sensor 2) Heater Sense Circuit Performance	NOx control active time since dew point exceeded > 180 Sec.

<b>DTC</b>	<b>Error Message</b>	<b>Malfunction Criteria and Threshold Value</b>
P220A	NOx Sensor Supply Voltage (Bank 1 Sensor 1) Circuit	Sensor supply voltage > 1.5 or < 12 V
P220B	NOx Sensor Supply Voltage (Bank 1 Sensor 2) Circuit	Sensor supply voltage > 1.5 or < 12 V
P2200	NOx Sensor (Bank 1 Sensor 1) Circuit	<ul style="list-style-type: none"> <li>• Exhaust temperature upstream SCR = 100 - 600 °C</li> <li>• Dewpoint exceeded</li> <li>• Measured A/F ratio (O2S) &gt; 1</li> <li>• NOx control = 1st activation</li> <li>• Exhaust temperature upstream SCR 100 - 600 °C</li> <li>• Steady state condition (actual filtered A/F ratio) O2S &lt; 0 - 0.2 for 5 Sec.</li> </ul>
P2201	NOx Sensor Circuit Range/ Performance (Bank 1 Sensor 1)	<ul style="list-style-type: none"> <li>• NOx 40 - 70%, time &gt; 5 Sec. or 40% value not reached within 7 Sec.</li> <li>• Ratio &gt; 3 or &lt; -0.75</li> <li>• Average NOx Offset value &gt; 50 or &lt; -30 ppm</li> </ul>
P2202	NOx Sensor (Bank 1 Sensor 1) Circuit Low	NOx value < -105 ppm
P2203	NOx Sensor (Bank 1 Sensor 1) Circuit High	NOx value > 1655 ppm
P2209	NOx Sensor Bank 1 Sensor 1 Heater Sense Circuit Performance	NOx control active time since dew point exceeded > 180 Sec.
P2237	O2 Sensor Positive Current Control Circuit (Bank 1 Sensor 1) Open	Measured oxygen concentration < 0.005
P2243	O2 Sensor Reference Voltage Circuit Bank 1 Sensor 1 Open	<ul style="list-style-type: none"> <li>• O2S internal resistance &gt; 3 V</li> <li>• Oxygen signal &lt; -1.3 V or &gt; 1.5 V</li> </ul>
P2251	O2 Sensor Negative Current Control Circuit Bank 1 Sensor 1 Open	<ul style="list-style-type: none"> <li>• O2S internal resistance &gt; 3 V</li> <li>• 1 V and &lt; 0.1 V</li> </ul>
P2263	Turbocharger Boost System Performance	Control deviation > 8%
P2279	Intake Air System Leak	Ratio of measured and modeled mass air flow < 0.45
P229E	NOx Sensor (Bank 1 Sensor 2) Circuit	NOx sensor status ratio > 0.5

DTC	Error Message	Malfunction Criteria and Threshold Value
P229F	NOx Sensor Circuit Range/ Performance (Bank 1 Sensor 2)	<ul style="list-style-type: none"> <li>• Delta of NOx value downstream SCR <math>\leq</math> 5 ppm after peak detection of NOx value upstream</li> <li>• Number of checks = 2</li> </ul> or <ul style="list-style-type: none"> <li>• Average NOx Offset value &gt; 50 or &lt; -30 ppm</li> </ul>
P2294	Fuel Pressure Regulator 2 Control Circuit	Diagnostic signal from power stage < 2.97 V
P2295	Fuel Pressure Regulator 2 Control Circuit Low	Diagnostic signal from power stage > 4.5 V
P2296	Fuel Pressure Regulator 2 Control Circuit High	Diagnostic signal from power stage > 2.7 A

### Additional Emissions Regulations

DTC	Error Message	Malfunction Criteria and Threshold Value
P24AE	Particulate Matter Sensor Circuit	Signal voltage negative connection < 0.3 V or > 4.7 V
P24AF	Particulate Matter Sensor Circuit Performance	Accumulated change in heater voltage $\leq$ 0.40 V
P24B1	Particulate Matter Sensor Circuit High	Signal voltage negative connection = 0 V or > 4.1 V
P24B3	Particulate Matter Sensor Heater Control Circuit/Open	Heating coil resistance < 1.06 to 2.31 $\Omega$
P24B5	Particulate Matter Sensor Heater Control Circuit Low	Heater current < 1.0 A or > 15 A
P24B6	Particulate Matter Sensor Heater Control Circuit High	Heater current $\geq$ 0.2 A
P24C6	Particulate Matter Sensor Temperature Circuit	<ul style="list-style-type: none"> <li>• Short to ground &gt; 0.3 V</li> <li>• O2S</li> </ul>
P24C7	Particulate Matter Sensor Temperature Circuit Range/ Performance	Measured sensor temperature vs. mean value of modeled temperature < -100 Kelvin
P24D0	Particulate Matter Sensor Supply Voltage Circuit Fault	Difference between measured PM sensor supply wire voltage and battery voltage at ECM > 1.90 V or 2.60 V or 3.00 V

<b>DTC</b>	<b>Error Message</b>	<b>Malfunction Criteria and Threshold Value</b>
P240F	Exhaust Gas Recirculation Slow Response	<ul style="list-style-type: none"> <li>• Calculated characteristic value (for positive gradients of desired air flow) &gt; 70</li> <li>or</li> <li>• Calculated characteristic value (for negative gradients of desired air flow) &gt; 50</li> </ul>
P242A	Exhaust Gas Temperature Sensor Circuit (Bank 1 Sensor 3)	Signal voltage > 1652 mV
P242B	Exhaust Gas Temperature Sensor Circuit Bank 1 Sensor 3 Range/Performance	<ul style="list-style-type: none"> <li>• Temperature difference to EGR temp, T3, T4, T5, T6 &gt; 60 °K</li> <li>or</li> <li>• Mean value of modeled - measured T5 &gt; 100 °K</li> </ul>
P242C	Exhaust Gas Temperature Sensor Circuit Low (Bank 1 Sensor 3)	Signal voltage < 330 mV
P2425	Exhaust Gas Recirculation Cooling Valve Control Circuit Open	Diagnostic signal from power stage > 4.5 V
P2426	Exhaust Gas Recirculation Cooling Valve Control Circuit Low	Diagnostic signal from power stage < 2.97 V
P2427	Exhaust Gas Recirculation Cooling Valve Control Circuit High	Diagnostic signal from power stage > 2.2 A
P244C	Exhaust Temperature Too Low For Particulate Filter Regeneration (Bank 1)	Time to closed loop 120 - 300 Sec.
P245B	Exhaust Gas Recirculation Cooler Bypass Control Circuit Range/Performance	Measured temperature < 0.8
P2452	Diesel Particulate Filter Differential Pressure Sensor Circuit	Sensor voltage > 4.9 V
P2453	Diesel Particulate Filter Differential Pressure Sensor Circuit Range/Performance	Pressure drop > 3 kPa or < -3 kPa
P2454	Diesel Particulate Filter Differential Pressure Sensor Circuit Low	Sensor voltage < 0.2 V

DTC	Error Message	Malfunction Criteria and Threshold Value
P2458	Diesel Particulate Filter Regeneration Duration	Time of regen duration > 3600 Sec
P2459	Diesel Particulate Filter Regeneration Frequency	Measured soot mass > f(volumetric flow rate) grams
P246E	Exhaust Gas Temperature Sensor Circuit (Bank 1 Sensor 4)	Signal voltage > 1652 mV
P246F	Exhaust Gas Temperature Sensor Circuit Bank 1 Sensor 4 Range/Performance	<ul style="list-style-type: none"> <li>• Temperature difference to EGR temp, T3, T4, T5, T6 &gt; 60 °K</li> <li>or</li> <li>• Mean value of modeled - measured T5 &gt; 100 °K</li> </ul>
P2463	Diesel Particulate Filter - Soot Accumulation	Calculated particulate matter trap loading > 40 g
P247A	Exhaust Gas Temperature Out of Range (Bank 1 Sensor 3)	Control deviation (T5) > 200 K or < -100 K
P2470	Exhaust Gas Temperature Sensor Circuit Low (Bank 1 Sensor 4)	Signal voltage < 330 mV
P2564	Turbocharger Boost Control Position Sensor Circuit Low	Sensor signal voltage < 0.15 V
P2565	Turbocharger Boost Control Position Sensor Circuit High	Sensor signal voltage > 4.85 V
P261A	Coolant Pump "B" Control Circuit/Open	<ul style="list-style-type: none"> <li>• Open circuit Signal voltage &lt; 5 V</li> <li>• Functional voltage = 3.2 - 3.5 V</li> </ul>
P261C	Coolant Pump "B" Control Circuit Low	Signal voltage < 3 V
P261D	Coolant Pump "B" Control Circuit High	Signal voltage > 1.8 V
P268A	Fuel Injector Calibration Not Learned/Programmed	Deviation to target rail pressure > 1500 - 2000 kPa for > 40 Sec.
P310E	Exhaust Gas Recirculation Cooler Bypass Valve 2 Implausible Signal	Measured temperature < 0.8
P3348	Turbocharger Control Unit Electrical Malfunction in Circuit	<ul style="list-style-type: none"> <li>• Diagnostic signal from power stage = 8 - 18 A</li> <li>or</li> <li>• Diagnostic signal from power stage &gt; 5 V or &lt; 3.4 V</li> </ul>

# DTC CHART

## Engine Code - CGFA

### Fuel and Air Mixture, Additional Emissions Regulations

DTC	Error Message	Malfunction Criteria and Threshold Value
P000A	Intake (A) Camshaft Position Slow Response (Bank 1)	<ul style="list-style-type: none"> <li>• Difference between target and actual position &gt; 12 to 40 °CRK for &gt; 3 Sec.</li> <li>• Adjustment angle <math>\geq 3</math> °CRK</li> </ul>
P000C	Intake (A) Camshaft Position Response Check (Bank 2)	<ul style="list-style-type: none"> <li>• Difference between target and actual position &gt; 12 to 40 °CRK for &gt; 3 Sec.</li> <li>• Adjustment angle <math>\geq 3</math> °CRK</li> </ul>
P00AB	Intake Air Temperature Sensor (Bank 2) Circuit Range/Performance	Difference between IAT after intercooler 2 vs. ECT at start > 26 °C or $\leq -26$ °C
P00AC	Intake Air Temperature Sensor (Bank 2) Circuit Low	Intake Air Temperature > 128 °C
P00AD	Intake Air Temperature Sensor (Bank 2) Circuit High	Intake Air Temperature < -39 °C
P00A2	Charge Air Temperature Sensor (Bank 2) Circuit Low	Intake Air Temperature < 0.1 V
P00A3	Charge Air Temperature Sensor (Bank 2) Circuit High	Intake Air Temperature > 3.20 V
P00C7	Charge Air Pressure Sensor 1 Correlation	Difference between Boost Pressure sensor 1 and 2 > 10.20 kPa
P0010	Intake (A) Camshaft Position Actuator Circuit/Open (Bank 1)	Signal voltage > 4.70 - 5.40 V
P0011	Intake (A) Camshaft Position Timing - Over-Advanced (Bank 1)	<ul style="list-style-type: none"> <li>• Difference between target and actual position &gt; 12 to 40 °CRK for &gt; 3 Sec.</li> <li>• Adjustment angle <math>\geq 3</math> °CRK</li> </ul>
P0016	Crankshaft Position - Camshaft Position Correlation (Bank 1, Sensor A)	<ul style="list-style-type: none"> <li>• Permissible deviation &lt; 14 °CRK</li> <li>or</li> <li>• Permissible deviation &gt; 14 °CRK</li> </ul>



DTC	Error Message	Malfunction Criteria and Threshold Value
P0018	Crankshaft Position to Intake Camshaft Position Correlation (Bank 2)	Permissible deviation < -14 °CRK or permissible deviation > 14 °CRK
P0020	Intake Camshaft Actuator Circuit Open (Bank 2)	Signal voltage 4.70 to 5.40 V
P0021	Intake Camshaft Timing - Over-Advanced (Bank 1)	<ul style="list-style-type: none"> <li>• Difference between target and actual position &gt; 12 to 40 °CRK for &gt; 3 Sec.</li> <li>• Adjustment angle ≥ 3 °CRK</li> </ul>
P0030	HO2S Heater Control Circuit (Bank 1, Sensor 1) Open Circuit	Heater voltage 4.70 to 5.40 V
P0031	HO2S Heater Control Circuit Low (Bank 1, Sensor 1) Short to Ground	Heater voltage < 2.34 V
P0032	HO2S Heater Control Circuit High (Bank 1, Sensor 1) Short to B+	Heater current > 5.50 A
P0036	HO2S Heater Control Circuit (Bank 1, Sensor 2) Open Circuit	Heater voltage 2.34 to 3.59 V
P0037	HO2S Heater Control Circuit Low (Bank 1, Sensor 2) Short to Ground	Heater voltage < 2.34 V
P0038	HO2S Heater Control Circuit High (Bank 1, Sensor 2) Short to B+	Heater voltage > 3.59 V
P0040	O2 Sensor Signals Swapped (Bank 1 Sensor 1 to Bank 2 Sensor 1)	Lambda controllers exceed thresholds in opposite directions
P0043	HO2S Heater Control Circuit Low (Bank 1, Sensor 2) Short to Ground	<ul style="list-style-type: none"> <li>• SULEV Heater voltage &lt; 3 V</li> <li>• ULEV Heater voltage &lt; 3 V</li> </ul>
P0044	HO2S Heater Control Circuit High (Bank 1, Sensor 2) Short to B+	Heater current > 2.70 - 5.50 A
P0050	HO2S Heater Control Circuit (Bank 1 Sensor 1)	Heater voltage 4.70 to 5.40 V
P0051	HO2S Heater Control Circuit Low (Bank 1 Sensor 1)	Heater voltage < 0.0 to 3.26 V
P0052	HO2S Heater Control Circuit High (Bank 1 Sensor 1)	Heater current > 5.50 A

<b>DTC</b>	<b>Error Message</b>	<b>Malfunction Criteria and Threshold Value</b>
P0056	HO2S Heater Control Circuit (Bank 2 Sensor 2)	Heater voltage 2.34 to 3.59 V
P0057	HO2S Heater Control Circuit (Bank 2 Sensor 2) Low	Heater voltage < 2.34 V
P0058	HO2S Heater Control Circuit (Bank 2 Sensor 2) High	Heater voltage > 3.59 V
P0068	MAP/MAF – Throttle Position Correlation	Deviation throttle controller < 43 or > 43%
P007C	Charge Air Temperature Sensor (Bank 1) Circuit Low	Intake Air Temperature < 0.099 V
P007D	Charge Air Temperature Sensor (Bank 1) Circuit High	Intake Air Temperature > 3.20 V
P0070	Ambient Air Temperature Sensor Circuit	Ambient air temp < -50.0 °C
P0071	Ambient Air Temperature Sensor Range/Performance	<ul style="list-style-type: none"> <li>• Difference ECT vs. IAT at engine start (depending on engine-off time) &lt; 25.5 K and</li> <li>• Difference AAT vs. ECT @ engine start (depending on engine-off time) &gt; 25.5 K</li> </ul>
P0072	Ambient Air Temperature Sensor Circuit Low	Ambient air temp > 87.0 °C
P008A	Low Pressure Fuel System Pressure Too Low	Actual pressure < 40 kPa
P008B	Low Pressure Fuel System Pressure Too High	Actual pressure > 780 kPa
P0087	Fuel Rail/System Pressure - Too Low	<ul style="list-style-type: none"> <li>• Pressure control activity &gt; 2.20 MPa</li> <li>• Fuel trim activity 0.90 to 15.99</li> <li>• Difference between target and actual &gt; 2.20 MPa</li> </ul>
P0088	Fuel Rail/System Pressure - Too High	Fuel rail pressure > 13.9 MPa or 780 kPa

DTC	Error Message	Malfunction Criteria and Threshold Value
P0089	Fuel Pressure Regulator 1 Performance	Functional check: <ul style="list-style-type: none"> <li>• Difference between actual vs. target pressure &gt; 200 kPa</li> </ul> OR Check 2: <ul style="list-style-type: none"> <li>• Difference between actual vs. target pressure &gt; 150 kPa</li> </ul> OR Check 3: <ul style="list-style-type: none"> <li>• Pressure control activity &gt; 225 kPa</li> </ul> OR Check 4: <ul style="list-style-type: none"> <li>• Pressure control activity &lt; -300 kPa</li> </ul>
P0111	Intake Air Temperature Sensor (Bank 1) Range/Performance	<ul style="list-style-type: none"> <li>• Difference IAT vs. ECT at engine start (depending on engine-off time &gt; 25.5 K and</li> <li>• Difference IAT vs. AAT at engine start (depending on engine-off time &gt; 25.5 K</li> </ul>
P0112	Intake Air Temperature Sensor (Bank 1) Circuit Low Input	Intake air temperature > 128 °C
P0113	Intake Air Temperature Sensor (Bank 1) Circuit High Input	Intake air temperature < -39°C
P0116	Engine Coolant Temperature Sensor 1 Circuit Range/ Performance	Stuck high <ul style="list-style-type: none"> <li>• No difference of min to max signal &lt; 1.5K</li> </ul> or <ul style="list-style-type: none"> <li>• Difference between ECT and IAT at cold engine &lt; 25.5 K</li> </ul>
P0117	Engine Coolant Temperature Sensor 1 Circuit Low	Engine coolant temperature 137 °C
P0118	Engine Coolant Temperature Sensor 1 Circuit High	Engine coolant temperature < -44 °C

DTC	Error Message	Malfunction Criteria and Threshold Value
P012B	Charge Air Pressure Sensor Circuit Range/Performance	<ul style="list-style-type: none"> <li>• Difference in boost pressure 1 downstream throttle to boost pressure &gt; 83.28 hPa or &lt; -83.28 hPa</li> <li>• Difference in boost pressure 2 downstream throttle to boost pressure &gt; 83.28 hPa or &lt; -83.28 hPa</li> </ul> or <ul style="list-style-type: none"> <li>• Difference pressure downstream throttle to average value of all pressure sensors at start &lt; -57.17 hPa or &gt; 51.17 hPa</li> </ul>
P012C	Charge Air Pressure Sensor Circuit Low	Signal voltage < 0.25 V
P012D	Charge Air Pressure Sensor Circuit High	Signal voltage > 4.85 V
P0121	Accelerator Pedal Position Sensor A Circuit Range/ Performance	<ul style="list-style-type: none"> <li>• TPS 1 vs. TPS 2 &gt; 6.30% and</li> <li>• TPS 1 calculated value &gt; TPS 2 calculated value</li> </ul>
P0122	Throttle/Pedal Position Sensor A Circuit Low Input	Signal voltage < 0.20 V
P0123	Accelerator Pedal Position Sensor A Circuit High Input	Signal voltage > 4.81 V
P0127	Intake Air Temperature Too High	IAT 1 or 2 > 100 °C
P013A	O2 Sensor Bank 1 Sensor 2 Slow Response - Rich to Lean	Arithmetic filtered max differential transient time at fuel cutoff $\geq$ 0.5 Sec. and number of checks $\geq$ 1
P013C	O2 Sensor (Bank 2 Sensor 2) Slow Response - Rich to Lean	Arithmetic filtered max differential transient time at fuel cutoff $\geq$ 0.5 Sec. and number of checks $\geq$ 1
P0130	O2 Sensor Circuit (Bank 1, Sensor 1)	O2S ceramic temperature < 640°C
P0131	O2 Sensor Circuit (Bank 1, Sensor 1) Low Voltage	Virtual mass < 1.75 V
		Nernst voltage < 1.50 V
		Adjustment voltage < 0.30 V

DTC	Error Message	Malfunction Criteria and Threshold Value
P0132	O2 Sensor Circuit (Bank 1, Sensor 1) High Voltage	Virtual mass > 3.25 V
		Nernst voltage > 4.40 V
		Adjustment voltage > 7.00 V
P0133	O2 Circuit Slow Response (Bank 1, Sensor 1)	<ul style="list-style-type: none"> <li>• Lower value of both area ratios R2L and L2R -0.35 to 0.35 for 2 times</li> <li>• Lower value of both counters for area ratio R2L and L2R <math>\geq 5</math> times</li> </ul>
P0135	O2 Heater Circuit (Bank 1, Sensor 1)	<ul style="list-style-type: none"> <li>• O2S ceramic temperature &lt; 685°C</li> <li>• Heater duty cycle &gt; 90%</li> </ul> or <ul style="list-style-type: none"> <li>• O2S ceramic temperature &lt; 720°C</li> <li>• Time after O2S heater on 40 Sec.</li> </ul>
P0136	O2 Sensor Circuit (Bank 1, Sensor 2) Fault	<ul style="list-style-type: none"> <li>• O2S signal rear not oscillating at reference 0.708 V</li> <li>• Signal voltage &gt; 0.02 V</li> </ul>
P0137	O2 Sensor Circuit (Bank 1, Sensor 2) Low Voltage	<ul style="list-style-type: none"> <li>• Signal voltage &lt; 0.04 V for time &gt; 3 Sec.</li> <li>• Voltage difference with vs. without load pulse &lt; 0.01 V</li> </ul>
P0138	O2 Circuit Circuit (Bank 1, Sensor 2) High Voltage	Signal voltage > 1.08 V for > 5 Sec.
P0139	O2 Sensor Circuit Slow Response (Bank 1 Sensor 2)	<ul style="list-style-type: none"> <li>• EWMA filtered transient time at fuel cut off &gt; 0.7 Sec. in voltage range 0.201 - 0.401 mV</li> <li>• Number of checks 3</li> </ul>
P0140	O2 Sensor Circuit No Activity Detected (Bank 1 Sensor 2)	<ul style="list-style-type: none"> <li>• Signal voltage .40 - .60 mV for &gt; 3 Sec</li> <li>• Voltage difference with vs. without load pulse <math>\geq 2.80</math> V</li> </ul>
P0141	O2 Sensor Heater Circuit (Bank 1, Sensor 2) Out of Range	Heater resistance, > 728 to 16632 $\Omega$
P0150	O2 Sensor Circuit Fault (Bank 2 Sensor 1)	O2S ceramic temperature < 640 °C

DTC	Error Message	Malfunction Criteria and Threshold Value
P0151	O2 Sensor Circuit (Bank 2 Sensor 1) Low Voltage	Virtual mass < 1.75 V
		Nernst voltage < 1.50 V
		Adjustment voltage < 0.30 V
P0152	O2 Sensor Circuit (Bank 2 Sensor 1) High Voltage	Virtual mass > 3.25 V
		Nernst voltage > 4.40 V
		Adjustment voltage > 7.00 V
P0153	O2 Circuit Slow Response (Bank 2 Sensor 1)	<ul style="list-style-type: none"> <li>• Lower value of both area ratios R2L and L2R -0.35 to 0.35 for 2 times</li> <li>• Lower value of both counters for area ratio R2L and L2R ≥ 5 times</li> </ul>
P0155	O2 Heater Circuit Fault (Bank 1 Sensor 1)	<ul style="list-style-type: none"> <li>• O2S ceramic temp &lt; 685 °C</li> <li>• Heater duty cycle &gt; 90%</li> </ul> or <ul style="list-style-type: none"> <li>• O2S ceramic temp &lt; 720 °C</li> <li>• Time after O2 heater on 40 Sec.</li> </ul>
P0156	O2 Sensor Circuit Fault (Bank 2 Sensor 2)	<ul style="list-style-type: none"> <li>• O2S signal rear not oscillating at reference 0.708 V</li> <li>• Signal voltage &gt; 0.2 V</li> </ul>
P0157	O2 Sensor Circuit Low Voltage (Bank 2 Sensor 2)	<ul style="list-style-type: none"> <li>• Signal voltage &lt; 0.04 V for &gt; 3 Sec.</li> <li>• Voltage difference with vs. without load pulse &lt; 0.01 V</li> </ul>
P0158	O2 Sensor Circuit High Voltage (Bank 2 Sensor 2)	Signal voltage > 1.08 V for > 5 Sec.
P0159	O2 Sensor Circuit Slow Response (Bank 2 Sensor 2)	<ul style="list-style-type: none"> <li>• EWMA filtered transient time at fuel cutoff &gt; 0.7 Sec. in voltage range 0.201 to 0.401 V</li> <li>• Number of checks 3</li> </ul>
P0160	O2 Sensor Circuit No Activity Detected (Bank 2 Sensor 2)	<ul style="list-style-type: none"> <li>• Signal voltage, 0.40 to 0.60 V for &gt; 3 Sec.</li> <li>• Voltage difference with vs. without load pulse ≥ 2.80 V</li> </ul>
P0161	O2 Heater Circuit (Bank 2 Sensor 2) out of range	Heater resistance, > 728 to 16632 Ω
P0169	Incorrect Fuel Composition	Air quantity vs. fuel delivery incorrect

DTC	Error Message	Malfunction Criteria and Threshold Value
P017B	Cylinder Head Temperature Sensor Circuit Fault	<ul style="list-style-type: none"> <li>• Difference between modelled and measured cylinder head temperature &gt; 9.8 K</li> <li>or</li> <li>• Difference between CHT and ECT (or CHT and IAT) at engine start <math>\geq</math> 25 K</li> </ul>
P017C	Cylinder Head Temperature Sensor Circuit Low	Signal voltage < 0.10 V
P017D	Cylinder Head Temperature Sensor Circuit High	Signal voltage > 4.65 V
P0171	System Too Lean (Bank 1)	Lean at idle Adaptive value > 0.0063 g/Rev
P0172	System Too Rich (Bank 1)	Too rich at idle Adaptive value < 0.0075 g/Rev)
P0174	Fuel System Too Lean, Bank 2	Lean at idle Adaptive value > 0.0063 g/Rev
P0175	Fuel System Too Rich Bank 2	Too rich at idle Adaptive value < 0.0075 g/Rev)
P0190	Fuel Rail Pressure Sensor Circuit	Signal voltage > 4.8 V
P0191	Fuel Rail Pressure Sensor Range/Performance	Actual pressure > 15 MPa or actual pressure < 0.005 MPa
P0192	Fuel Rail Pressure Sensor A Circuit Low Input	Signal voltage < 0.2 V
P0196	Engine Oil Temperature Sensor Range/Performance	Difference of engine oil temp vs. ECT or oil temp vs. IAT, at startup > 25 K (high check) or $\leq$ -25 K (low check)
P0197	Engine Oil Temperature Sensor Circuit Low	Sensor signal short to voltage for > 10 Sec.
P0198	Engine Oil Temperature Sensor Circuit High	Sensor signal short to ground for > 10 Sec.
P0201	Injector Circuit/Open - Cylinder 1	<ul style="list-style-type: none"> <li>• Low side signal current &lt; 2.1 A</li> <li>• Internal logic failure</li> </ul>
P0202	Injector Circuit/Open - Cylinder 2	<ul style="list-style-type: none"> <li>• Low side signal current &lt; 2.1 A</li> <li>• Internal logic failure</li> </ul>
P0203	Injector Circuit/Open - Cylinder 3	<ul style="list-style-type: none"> <li>• Low side signal current &lt; 2.1 A</li> <li>• Internal logic failure</li> </ul>
P0204	Injector Circuit/Open - Cylinder 4	<ul style="list-style-type: none"> <li>• Low side signal current &lt; 2.1 A</li> <li>• Internal logic failure</li> </ul>

<b>DTC</b>	<b>Error Message</b>	<b>Malfunction Criteria and Threshold Value</b>
P0205	Injector Circuit/Open - Cylinder 5	<ul style="list-style-type: none"> <li>• Low side signal current &lt; 2.1 A</li> <li>• Internal logic failure</li> </ul>
P0206	Injector Circuit/Open - Cylinder 6	<ul style="list-style-type: none"> <li>• Low side signal current &lt; 2.1 A</li> <li>• Internal logic failure</li> </ul>
P0221	Accelerator Pedal Position Sensor B Circuit Range/Performance	<ul style="list-style-type: none"> <li>• TPS 1 vs. TPS 2 &gt; 6.30% and</li> <li>• TPS 1 calculated value &gt; TPS 2 calculated value</li> </ul>
P0222	Accelerator Pedal Position Sensor B Circuit Low Input	Signal voltage < 0.20 V
P0223	Accelerator Pedal Position Sensor B Circuit High Input	Signal voltage > 4.81 V
P023A	Charge Air Cooler Coolant Pump Control Circuit Open	Signal voltage 4.8 to 5.3 V
P023B	Charge Air Cooler Coolant Pump Control Circuit Low	Signal voltage < 2.8 to 3.2 V
P023C	Charge Air Cooler Coolant Pump Control Circuit High	Signal current > 2.2 to 4 A
P0234	Turbocharger/Supercharger Overboost Condition Rationality Check	Difference of set value boost pressure vs. actual boost pressure value > 200 - 1275 hPa
P0235	Charge Air Pressure Sensor A Circuit Fault	Boost pressure sensor signal vs target value > 27 - 50 kPa, depending on altitude
P0236	Charge Air Pressure Sensor A Circuit Performance	<ul style="list-style-type: none"> <li>• Difference in boost pressure lower threshold &lt; 0 hPa or upper threshold &gt; 0 hPa</li> <li>• Model range lower threshold 173 to 2500 hPa or upper threshold 224 to 4419 hPa</li> </ul>
P0237	Charge Air Pressure Sensor A Circuit Low	Signal voltage < 0.25 V
P0238	Charge Air Pressure Sensor A Circuit High	Signal voltage > 4.75 V
P0240	Charge Air Pressure Sensor B Circuit Performance	<ul style="list-style-type: none"> <li>• Difference in boost pressure lower threshold &lt; 0 hPa or upper threshold &gt; 0 hPa</li> <li>• Model range lower threshold 173 to 2500 hPa or upper threshold 224 to 4419 hPa</li> </ul>



DTC	Error Message	Malfunction Criteria and Threshold Value
P0241	Charge Air Pressure Sensor B Circuit Low	Signal voltage < 0.25 V
P0242	Charge Air Pressure Sensor B Circuit High	Signal voltage > 4.75 V
P025A	Fuel Pump Module Control Circuit Open	Signal current < 0.8 mA or signal voltage = 4.8 to 5.3 V
P025C	Fuel Pump Module Control Range/Performance	Signal voltage < 2.0 V
P025D	Fuel Pump Module Control Circuit High	Signal current > 0.60 A
P026A	Charge Air Cooler Efficiency Below Threshold	Difference between measured IAT and modeled IAT > 8 K
P0261	Cylinder 1 Injector Circuit Low	Signal current < 2.1 A
P0262	Cylinder 1 Injector Circuit High	Signal current > 14.70 A
P0264	Cylinder 2 Injector Circuit Low	Signal current < 2.1 A
P0265	Cylinder 2 Injector Circuit High	Signal current > 14.70 A
P0267	Cylinder 3 Injector Circuit Low	Signal current < 2.1 A
P0268	Cylinder 3 Injector Circuit High	Signal current > 14.70 A
P0270	Cylinder 4 Injector Circuit Low	Low side signal current < 2.1 A
P0271	Cylinder 4 Injector Circuit High	Signal current > 14.70 A
P0273	Cylinder 5 Injector Circuit Low	Low side signal current < 2.1 A
P0274	Cylinder 5 Injector Circuit High	Signal current > 14.70 A
P0276	Cylinder 6 Injector Circuit Low	Low side signal current < 2.1 A
P0277	Cylinder 6 Injector Circuit High	Signal current > 14.70 A
P0299	Supercharger Underboost Condition	Difference of set boost pressure vs. actual boost pressure value > 150 hPa
P2004	Intake Manifold Runner Control (Bank 1) Stuck Open	Difference between target and actual position > 40%
P2005	Intake Manifold Runner Control Bank 2 Stuck Open	Difference between target and actual position > 40%
P2006	Intake Manifold Runner Control Bank 1 Stuck Closed	Difference between target and actual position > 40%
P2007	Intake Manifold Runner Control Bank 2 Stuck Closed	Difference between target and actual position > 40%
P2008	Intake Manifold Runner Control (Bank 1) Circuit/Open	Signal voltage 4.70 to 5.40 V

<b>DTC</b>	<b>Error Message</b>	<b>Malfunction Criteria and Threshold Value</b>
P2009	Intake Manifold Runner (Bank 1 Control Circuit Low	Signal voltage 0 to 3.26 V
P2010	Manifold Runner (Bank 1) Control Circuit High	Signal current > 2.20 A
P2014	Intake Manifold Runner (Bank 1) Position Sensor Circuit	Signal voltage, < 0.2 V
P2015	Intake Manifold Runner (Bank 1) Position Sensor/Switch Circuit Range/Performance	Difference between target and actual position > 40%
P2017	Intake Manifold Runner Position Sensor/Switch Circuit High	Signal voltage > 4.88 V
P2019	Intake Manifold Runner Position Sensor/Switch Circuit (Bank 2)	Signal voltage, < 0.2 V
P2020	Intake Manifold Runner Pos. Sen./Switch Circuit Bank 2 Range/Performance	<ul style="list-style-type: none"> <li>• Difference between target and actual position &gt; 40%</li> <li>• Actual position NOT 0 to 100%</li> </ul>
P2022	Intake Manifold Runner Position Sensor (Bank 2) Circuit High	Signal voltage > 4.88 V
P2088	Camshaft Position A Actuator Control Circuit Low (Bank 1) Short to Ground	Signal voltage 0 to 3.25 V
P2089	Camshaft Position A Actuator Control Circuit High (Bank 1) Short to B+	Signal current > 2.2 A
P2092	A Camshaft Position Actuator Control Circuit (Bank 2) Low	Signal voltage 0 to 3.25 V
P2093	A Camshaft Position Actuator Control Circuit (Bank 2) High	Signal current, > 2.20 A
P2096	Post-Catalyst Fuel Trim System Too Lean (Bank 1)	Integral part of trim control, post cat < -0.035
P2097	Post-Catalyst Fuel Trim System Too Rich (Bank 1)	Integral part of trim control, post cat > 0.035
P2098	Post Catalyst Fuel Trim System (Bank 2) Too Lean	Integral part of trim control, post cat < -0.035
P2099	Post Catalyst Fuel Trim System (Bank 2) Too Rich	Integral part of trim control, post cat > 0.035

## Ignition System

DTC	Error Message	Malfunction Criteria and Threshold Value
P0300	Random Misfire Detected	<ul style="list-style-type: none"> <li>• Emission threshold misfire rate (MR) &gt; 2.2%</li> <li>• Catalyst damage misfire rate (MR) &gt; 1.2- 14%</li> </ul>
P0301	Cylinder 1 Misfire Detected	<ul style="list-style-type: none"> <li>• Emission threshold misfire rate (MR) &gt; 2.2%</li> <li>• Catalyst damage misfire rate (MR) &gt; 1.2 - 15.7%</li> </ul>
P0302	Cylinder 2 Misfire Detected	<ul style="list-style-type: none"> <li>• Emission threshold misfire rate (MR) &gt; 2.2%</li> <li>• Catalyst damage misfire rate (MR) &gt; 1.2 - 15.7%</li> </ul>
P0303	Cylinder 3 Misfire Detected	<ul style="list-style-type: none"> <li>• Emission threshold misfire rate (MR) &gt; 2.2%</li> <li>• Catalyst damage misfire rate (MR) &gt; 1.2 - 15.7%</li> </ul>
P0304	Cylinder 4 Misfire Detected	<ul style="list-style-type: none"> <li>• Emission threshold misfire rate (MR) &gt; 2.2%</li> <li>• Catalyst damage misfire rate (MR) &gt; 1.2 - 15.7%</li> </ul>
P0305	Cylinder 5 Misfire Detected	<ul style="list-style-type: none"> <li>• Emission threshold misfire rate (MR) &gt; 2.2%</li> <li>• Catalyst damage misfire rate (MR) &gt; 1.2 - 15.7%</li> </ul>
P0306	Cylinder 6 Misfire Detected	<ul style="list-style-type: none"> <li>• Emission threshold misfire rate (MR) &gt; 2.2%</li> <li>• Catalyst damage misfire rate (MR) &gt; 1.2 - 15.7%</li> </ul>
P0321	Ignition/Distributor Engine Speed Input Circuit Range/ Performance	<ul style="list-style-type: none"> <li>• Counted teeth vs. reference incorrect</li> <li>or</li> <li>• Monitoring reference gap failure</li> </ul>
P0322	Ignition/Distributor Engine Speed Input Circuit No Signal	<ul style="list-style-type: none"> <li>• Camshaft signal &gt; 3</li> <li>• Engine speed no signal</li> </ul>
P0324	Knock Control System Error	<ul style="list-style-type: none"> <li>• Signal fault counter (combustion) &gt; 28</li> <li>or</li> <li>• Signal fault counter (measuring window) &gt; 5.00</li> </ul>

DTC	Error Message	Malfunction Criteria and Threshold Value
P0326	Knock Sensor 1 Circuit Range/Performance	<ul style="list-style-type: none"> <li>• Lower threshold &lt; 0.029 V</li> <li>• Upper threshold &gt; 1.992 V</li> </ul>
P0327	Knock Sensor 1 Circuit Low Input	<ul style="list-style-type: none"> <li>• Lower threshold &lt; 0.30 to 2.50 V or &lt; -0.70 V</li> </ul>
P0328	Knock Sensor 1 Circuit High Input	Upper threshold > 113.09 to 240.0 V
P0331	Knock Sensor 2 Circuit Range/Performance	<ul style="list-style-type: none"> <li>• Lower threshold &lt; 0.029 V</li> <li>• Upper threshold &gt; 1.992 V</li> </ul>
P0332	Knock Sensor 2 Circuit Low Input	Lower threshold < 0.30 to 2.50 V or < -0.70 V
P0333	Knock Sensor 2 Circuit High Input	Upper threshold > 51.54 to 120 V
P0341	Camshaft Position Sensor A Circuit Range/Performance	Signal pattern incorrect and defect counter at 12
P0342	Camshaft Position Sensor A Circuit Low Input	<ul style="list-style-type: none"> <li>• Signal voltage low</li> <li>• Crankshaft signals = 8</li> </ul>
P0343	Camshaft Position Sensor A Circuit High Input	<ul style="list-style-type: none"> <li>• Signal voltage high</li> <li>• Crankshaft signals = 8</li> </ul>
P0346	Camshaft Position Sensor Bank 2 Circuit Range/Performance	Signal pattern incorrect and defect counter at 12
P0347	Camshaft Position Sensor Bank 2 Circuit Low	Signal voltage permanently low and crankshaft signals, 8.0
P0348	Ignition Coil A Primary/Secondary Circuit	Signal current < 0.25 to -2 mA or internal check failed
P0351	Ignition Coil A Primary/Secondary Circuit	<ul style="list-style-type: none"> <li>• Signal current &lt; 0.25 to -2.0 mA</li> <li>• Internal check failed</li> </ul>
P0352	Ignition Coil B Primary/Secondary Circuit	<ul style="list-style-type: none"> <li>• Signal current &lt; 0.25 to -2.0 mA</li> <li>• Internal check failed</li> </ul>
P0353	Ignition Coil C Primary/Secondary Circuit	<ul style="list-style-type: none"> <li>• Signal current &lt; 0.25 to -2.0 mA</li> <li>• Internal check failed</li> </ul>
P0354	Ignition Coil D Primary/Secondary Circuit	<ul style="list-style-type: none"> <li>• Signal current &lt; 0.25 to -2.0 mA</li> <li>• Internal check failed</li> </ul>
P0355	Ignition Coil E Primary/Secondary Circuit	<ul style="list-style-type: none"> <li>• Signal current &lt; 0.25 to -2.0 mA</li> <li>• Internal check failed</li> </ul>

DTC	Error Message	Malfunction Criteria and Threshold Value
P0356	Ignition Coil F Primary/ Secondary Circuit	<ul style="list-style-type: none"> <li>Signal current &lt; 0.25 to -2.0 mA</li> <li>Internal check failed</li> </ul>

### Additional Exhaust Regulation

DTC	Error Message	Malfunction Criteria and Threshold Value
P0410	Secondary Air Injection System Malfunction	Difference of ambient pressure vs. AIR pressure measured by AIR pressure sensor > 20 hPa
P0413	Secondary Air Injection Switching Valve A Circuit Open	Signal voltage 4.70 to 5.40 V
P0414	Secondary Air Injection Switching Valve A Circuit Shorted	<ul style="list-style-type: none"> <li>Signal voltage 0.0 to 3.25 V or</li> <li>Signal current &gt; 2.20 A</li> </ul>
P0415	Secondary Air Injection Switching Valve B Circuit Malfunction	Signal current 2.20 - 4.20 A
P0416	Secondary Air Injection Switching Valve B Circuit Open	Signal voltage 4.70 to 5.40 V
P0417	Secondary Air Injection Switching Valve B Circuit Shorted	<ul style="list-style-type: none"> <li>Signal voltage 0.0 to 3.25 V or</li> <li>Signal current &gt; 2.20 A</li> </ul>
P0418	Secondary Air Injection System Relay Circuit	Signal voltage 4.70 to 5.40 V
P0420	Catalyst System Bank 1 Efficiency Below Threshold	Measured Oxygen Storage Content < 1.00
P043E	Evaporative Emission System Leak Detection Reference Low Flow	EVAP pump current during reference measurement > 40 mA
P043F	Evaporative Emission System Leak Detection Reference High Flow	EVAP pump current during reference measurement < 15 mA
P0430	Catalyst System Bank 2 Efficiency Below Threshold	Measured Oxygen Storage Content < 1.00
P0441	Evaporative Emission System Incorrect Purge Flow	<ul style="list-style-type: none"> <li>Actual pump current &gt; 1.50 or</li> <li>Drop of EVAP pump current &lt; 1 mA within 5 Sec.</li> </ul>

<b>DTC</b>	<b>Error Message</b>	<b>Malfunction Criteria and Threshold Value</b>
P0442	Evaporative Emission System Leak Detected (Small Leak)	Modeled pressure from pump current < 7.00 hPa
P0444	Evaporative Emission System Purge Control Valve Circuit Open	Signal voltage > 4.70 - 5.40 V
P0445	Evaporative Emission System Purge Control Valve Shorted	Signal voltage < 2.0 V or Signal current >1.0 A
P0447	Evaporative Emission System Vent Control Circuit Open	Signal voltage > 4.7 to 5.4 V
P0448	Evaporative Emission System Vent Control Circuit Shorted	Signal voltage < 2.74 to 3.26 V or signal current > 2.2 to 4.0 A
P0455	Evaporative Emission System (Gross Leak) Leak Detected	Time for pressure drop < 0.6 - 0.7 Sec.
P0456	Evaporative Emission System (Very Small Leak) Leak Detected	EVAP system leakage area calculated from pump current curve > 0.2 (mm <sup>2</sup> )
P0458	Evaporative Emission System Purge Control Valve Circuit Low	Signal voltage 0.0 to 3.26 V
P0459	Evaporative Emission System Purge Control Valve Circuit High	Signal current > 2.2 A
P0491	Secondary Air Injection System (Bank 1) Insufficient Flow	<ul style="list-style-type: none"> <li>• AIR pressure measured with AIR pressure vs. modeled &lt; 29.7 to 39.8%</li> <li>or</li> <li>• Difference of ambient pressure vs. AIR pressure measured by AIR pressure sensor &gt; 20 hPa</li> </ul>
P0492	Secondary Air Injection System (Bank 2) Insufficient Flow	<ul style="list-style-type: none"> <li>• AIR pressure measured with AIR pressure vs. modeled &lt; 29.7 to 39.8%</li> <li>or</li> <li>• Difference of ambient pressure vs. AIR pressure measured by AIR pressure sensor &gt; 20 hPa</li> </ul>

## Speed and Idle Control

DTC	Error Message	Malfunction Criteria and Threshold Value
P050A	Cold Start Idle Air Control System Performance	<ul style="list-style-type: none"> <li>• Out of range low</li> <li>• Engine speed deviation &gt; 200 RPM</li> <li>• Out of range high</li> <li>• Engine speed deviation &gt; 80 - 50 RPM</li> </ul>
P050B	Cold Start Ignition Timing Performance	Difference between commanded and actual spark timing > 26%
P0501	Vehicle Speed Sensor A Range/Performance	VSS signal < 4 km/h
P0506	Idle Air Control System - RPM Lower Than Expected	Engine speed deviation > 100 RPM, and RPM torque value ≥ calculated max. value
P0507	Idle Air Control System - RPM Higher Than Expected	Engine speed deviation < -100 RPM, and RPM torque value ≤ calculated min. value
P052A	Cold Start Camshaft Position Timing Bank 1 Over-Advanced	Difference between target and actual position > 12 to 40 °CRK
P052C	Cold Start Camshaft Position Timing Bank 2 Over-Advanced	Difference between target and actual position > 12 to 40 °CRK
P053F	Cold Start Fuel Pressure Performance	<ul style="list-style-type: none"> <li>• Difference between target pressure vs. actual pressure, &gt; 1.50mPa</li> <li>• Difference between target pressure vs. actual pressure, &lt; -1.50 mPa</li> </ul>

## Control Module and Output Signals

DTC	Error Message	Malfunction Criteria and Threshold Value
P0601	Internal Control Module Memory Check Sum Error	Internal check sum, incorrect
P0604	Internal Control Module Random Access Memory (RAM) Error	Write ability check, failed
P0606	Control Module Processor Fault	Internal check failed
P062B	Internal Control Module Fuel Injector Control Performance	SPI communication check identifier failure

DTC	Error Message	Malfunction Criteria and Threshold Value
P0634	ECM Internal Temperature Too High	Power stage temperature > 170 °C
P0638	Throttle Actuator Control (Bank 1) Range/Performance	Functional check: close movement <ul style="list-style-type: none"> <li>• Time to close to reference point &gt; 0.6 Sec.</li> <li>• Reference point 2.88%</li> </ul> Signal range check at mechanical stop low <ul style="list-style-type: none"> <li>• TPS 1 signal voltage not 0.40 to 0.80 V</li> </ul> or <ul style="list-style-type: none"> <li>• TPS 2 signal voltage not 4.20 to 5.18 V</li> </ul>
P0641	Sensor Reference Voltage A Circuit/Open	Signal voltage deviation $\pm$ 0.3 V
P0651	Sensor Reference Voltage B Circuit/Open	Signal voltage deviation $\pm$ 0.3 V
P0697	Sensor Reference Voltage C Circuit/Open	Signal voltage deviation $\pm$ 0.3 V
U0001	High Speed CAN Communication Bus	CAN message, no feedback
U0002	High Speed CAN Communication Bus	Global time out, receiving no messages
U0100	Lost Communication with ECM/PCM A	<ul style="list-style-type: none"> <li>• Failure of all CAN engine messages, time out &gt; 490 mSec.</li> <li>• Failure of all CAN engine messages, but not all CAN messages, time out &gt; 1010 mSec.</li> </ul>
U0028	Vehicle Communication Bus A	CAN message no feedback
U0029	Vehicle Communication Bus A Performance	Global time out, receiving no messages
U0101	Lost Communication with TCM	No message received from TCM
U0110	Lost Communication With Drive Motor Control Module "A"	No CAN messages received from DMCM
U0112	Lost Communication With Battery Energy Control Module "B"	No CAN messages received from BECM



<b>DTC</b>	<b>Error Message</b>	<b>Malfunction Criteria and Threshold Value</b>
U0121	Lost Communication With Anti-Lock Brake System (ABS) Control Module	No CAN communication with ABS, time-out
U0140	Lost Communication with Body Control Module	CAN message no message
U0146	Lost Communication with Gateway "A"	CAN communication with gateway no message received
U0155	Lost Communication With Instrument Panel Cluster (IPC) Control Module	No CAN communication with IPC, time-out
U0302	Software Incompatibility with Transmission Control Module	Manual transmission vehicle, ECM coded as AT vehicle.
U0402	Invalid Data Received From Transmission Control Module	Implausible message received
U0411	Invalid Data Received From Drive Motor Control Module "A"	Implausible message received from DMCM
U0413	Invalid Data Received From Battery Energy Control Module "B"	Implausible message received from BECM
U0415	Invalid Data Received From Anti-Lock Brake System Control Module	Speed sensor signal out of range > 325 km/h or implausible message received from ABS module
U0422	Invalid Data Received From Body Control Module	Ambient temp. value (initialization), 00h
U0423	Invalid Data Received From Instrument Panel Cluster Control Moduler	Invalid data received from IPC implausible message
U0447	Invalid Data Received From Gateway "A"	Implausible message received from Gateway
U10DD	Clutch Actuator Missing Message	No CAN messages received from Clutch Control Unit
U10DE	Clutch Actuator Implausible Message	Implausible message received from CCU
U1103	Production mode active	Production mode active
U309C	Separating clutch adjuster Mechanical fault	Actuator voltage failure.

## Fuel and Air Ratios Control Module

DTC	Error Message	Malfunction Criteria and Threshold Value
P10A0	Supercharger Control Flap Signal Range Check	Signal range check • ECM power stage failure
P10A4	Supercharger Control Flap Actuator, Functional Check	• Duty cycle > 68 to 108% or • Deviation between set point and actual angle > 6%
P10A5	Supercharger Control Flap Sensor, Short to Voltage	Sensor voltage > 4.82 V
P10A6	Supercharger Control Flap sensor short circuit	Sensor voltage < 0.30 V
P10A7	Adaption For Supercharger Control Flap Sticking	Sensor signal > 0.80
P10A8	Adaption For Supercharger Control Flap Lower Stop Not Reached	Sensor signal < 0.41
P12A1	Fuel Rail Pressure Sensor Inappropriately Low	• Pressure control activity > 0.10 MPa • Fuel trim activity < 0.80 • Difference between target and actual pressure -16 to 16.38 MPa
P12A2	Fuel Rail Pressure Sensor Inappropriately High	• Pressure control activity < -0.08 MPa • Fuel trim activity > 1.25 • Difference between target and actual pressure -16 to 16.38 MPa
P12A4	Fuel Rail Pump Control Valve Stuck Closed	• Fuel trim activity 0.85 to 1.15 • Fuel and • Pressure control activity < 6.0 mPa
P13EA	Cold Start Ignition Timing Performance Off Idle	Difference between commanded and actual spark timing > 13%
P1335	Engine Torque Monitoring 2 Control Limit Exceeded	Internal calculated engine torque incorrect
P1427	Brake Vacuum Pump Activation Short Circuit to B+	Signal current > 2.2 A

DTC	Error Message	Malfunction Criteria and Threshold Value
P1428	Brake Vacuum Pump Activation Short Circuit to Ground	Signal voltage < 2.15 V
P1429	Brake Vacuum Pump Activation Open Circuit	Signal voltage 4.40 to 5.60 V
P1479	Brake Vacuum System Mechanical Malfunction	<ul style="list-style-type: none"> <li>• Brake boost pressure high &gt; 1300 hPa or low &lt; 40 hPa</li> <li>or</li> <li>• Difference brake booster pressure vs. ambient pressure &gt; 100 hPa or gradient brake booster pressure &gt; 1.5 kPa</li> </ul>
P150A	Engine Off Time Performance	Difference between engine off time and ECM after run time < -8 or > 8 Sec.
P169A	Loading Mode Active	Transport mode active
P1609	Crash Shut-Off Was Triggered	Airbags activated
P1912	Pressure Sensor for Brake Booster Open Circuit/Short Circuit to B+	Sensor voltage > 4.80 V
P1913	Pressure Sensor for Brake Booster Short Circuit to Ground	Sensor voltage < 0.20 V
P2101	Throttle Actuator A Control Motor Circuit Range/Performance	<ul style="list-style-type: none"> <li>• Duty cycle &gt; 80% and no ECM power stage failure</li> <li>or</li> <li>• Deviation throttle value angles vs. calculated value &gt; 4 to 50%</li> </ul>
P2122	Throttle/Pedal Position Sensor/Switch D Circuit Low Input	Signal voltage < 0.65 V
P2123	Throttle/Pedal Position Sensor/Switch D Circuit High Input	Signal voltage > 4.89 V
P2127	Throttle/Pedal Position Sensor/Switch E Circuit Low Input	Signal voltage < 0.28 V
P2128	Throttle/Pedal Position Sensor/Switch E Circuit High Input	Signal voltage > 2.64 V

<b>DTC</b>	<b>Error Message</b>	<b>Malfunction Criteria and Threshold Value</b>
P2138	Throttle/Pedal Position Sensor/Switch D/E Voltage Correlation	Signal voltage sensor 1 vs 2 > 0.14 - 0.26 V
P2146	Fuel Injector Group A Supply Voltage Circuit/Open	Signal current, > 14.90 A or < 2.60 V
P2149	Fuel Injector Group B Supply Voltage Circuit/Open	Signal current, > 14.90 A or < 2.60 V
P2152	Fuel Injector C Supply Voltage Circuit Open	Signal current, > 14.90 A or < 2.60 V
P2155	Fuel Injector D Supply Voltage Circuit Open	Signal current, > 14.90 A or < 2.60 V
P2177	System Too Lean Off Idle (Bank 1)	Adaptive value > 30%
P2178	System Too Rich Off Idle (Bank 1)	Adaptive value < -30%
P2179	System Too Lean Off Idle (Bank 2)	Adaptive value > 30%
P2180	System Too Rich Off Idle (Bank 2)	Adaptive value < -30%
P2181	Cooling System Performance	<ul style="list-style-type: none"> <li>• ECT temperature too low after a sufficient air mass flow integral &lt; 48 to 75 °C</li> <li>or</li> <li>• Filtered ECT decreases under a threshold value after reaching a high temperature level &lt; 28 to 45 °C</li> </ul>
P2184	Engine Coolant Temperature Sensor 2 Circuit Low	Signal voltage < 0.10 V
P2185	Engine Coolant Temperature Sensor 2 Circuit High	Signal voltage > 4.94 V
P2187	System Too Lean at Idle (Bank 1)	Adaptive value > 6%
P2188	System Too Rich at Idle (Bank 1)	Adaptive value < -6.0%
P2189	System Too Lean at Idle Bank 2	Adaptive value > 6%
P2190	System Too Rich at Idle Bank 2	Adaptive value < -6%

DTC	Error Message	Malfunction Criteria and Threshold Value
P2195	O2 Sensor Signal Biased/ Stuck Lean (Bank 1, Sensor 1)	Delta lambda of 2nd lambda control loop > 0.059
P2196	O2 Sensor Signal Biased/ Stuck Rich (Bank 1, Sensor 1)	Delta lambda of 2nd lambda control loop < -0.059 V
P2197	O2 Sensor Signal Biased/ Stuck Lean (Bank 2 Sensor 1)	Delta lambda of 2nd lambda control loop > 0.059 V
P2198	O2 Sensor Signal Biased/ Stuck Rich Bank 2 Sensor 1	Delta lambda of 2nd lambda control loop < -0.059 V
P2199	Intake Air Temperature Sensor 1/2 Correlation	Difference between IAT 1 and IAT 2 > 10 °C
P2237	O2 Sensor Positive Current Control Circuit/Open (Bank 1, Sensor 1)	<ul style="list-style-type: none"> <li>• O2S signal front 1.49 to 1.51 V</li> <li>• Delta lambda controller &gt; 0.07.</li> </ul>
P2240	O2 Sensor Positive Current Control Circuit Open Bank 2 Sensor 1	<ul style="list-style-type: none"> <li>• O2S signal front 1.49 to 1.51 V</li> <li>• Delta lambda controller &gt; 0.07</li> </ul>
P2243	O2 Sensor Reference Voltage Circuit/Open (Bank 1, Sensor 1)	<ul style="list-style-type: none"> <li>• O2S signal front &gt; 4.80 V or &lt; 0.25 V</li> <li>• Internal resistance &gt; 950 ohm</li> </ul>
P2247	O2 Sensor Reference Voltage Circuit Open (Bank 2 Sensor 1)	<ul style="list-style-type: none"> <li>• O2S signal front &gt; 4.80 V or &lt; 0.25 V</li> <li>• Internal resistance &gt; 950 ohm</li> </ul>
P2251	O2 Sensor Negative Current Control Circuit Open (Bank 1 Sensor 1)	<ul style="list-style-type: none"> <li>• O2S signal front 1.47 to 1.52 V</li> <li>• Internal resistance &gt; 950 ohm</li> </ul>
P2254	O2 Sensor Negative Current Control Circuit Open (Bank 2 Sensor 1)	<ul style="list-style-type: none"> <li>• O2S signal front 1.47 to 1.52 V</li> <li>• Internal resistance &gt; 950 ohm</li> </ul>
P2257	Secondary Air Injection System Control "A" Circuit Low	Signal voltage 0.0 to 3.26 V
P2258	Secondary Air Injection System Control Circuit High	Signal current 0.60 - 2.40 A
P226B	Supercharger Boost Pressure Too High - Mechanical	Boost pressure > 250 kPa
P2262	Supercharger Boost Pressure Not Detected - Mechanical	Ratio between boost pressure and manifold pressure < 1 to 1.25
P2263	Supercharger Boost System Performance	Difference between set point and actual boost pressure > 25 to 75 kPa

<b>DTC</b>	<b>Error Message</b>	<b>Malfunction Criteria and Threshold Value</b>
P2270	O2 Sensor Signal Biased/ Stuck Lean (Bank 1 Sensor 2)	O2S signal rear not oscillating at reference < 0.66 V and enrichment after stuck lean 25%
P2271	O2 Sensor Signal Stuck Rich (Bank 1, Sensor 2)	<ul style="list-style-type: none"> <li>• O2S signal rear not oscillating at reference &gt; 0.66 V and enleanment after stuck rich 15%</li> <li>or</li> <li>• Measurement range from fuel cutoff to voltage threshold <math>\leq 0.15</math> V</li> <li>• Number of checks <math>\geq 1</math></li> </ul>
P2272	O2 Sensor Signal Biased/ Stuck Lean Bank 2 Sensor 2	O2S signal rear not oscillating at reference < 0.66 V and enrichment after stuck lean 25%
P2273	O2 Sensor Signal Biased/ Stuck Rich Bank 2 Sensor 2	<ul style="list-style-type: none"> <li>• O2S signal rear not oscillating at reference &gt; 0.66 V and enleanment after stuck rich 15%</li> <li>or</li> <li>• Measurement range from fuel cutoff to voltage threshold <math>\leq 0.15</math> V</li> <li>• Number of checks <math>\geq 1</math></li> </ul>
P2279	Intake Air System Leak	Offset value throttle mass flow > 15 kg/h
P2293	Fuel Pressure Regulator 2 Performance	<ul style="list-style-type: none"> <li>• Difference between target pressure vs. actual pressure: &gt; 1.50 mPa</li> <li>• Difference between target pressure vs. actual pressure, &lt; -1.50 MPa</li> </ul>
P2294	Fuel Pressure Regulator 2 Control Circuit	Signal voltage 1.40 to 3.20 V or signal pattern incorrect.
P2295	Fuel Pressure Regulator 2 Control Circuit Low Short to Ground	Signal voltage 1.40 - 3.20 V
P2296	Fuel Pressure Regulator 2 Control Circuit High	Signal voltage > 3.20 V

## Ignition System

DTC	Error Message	Malfunction Criteria and Threshold Value
P2300	Ignition Coil A Primary Control Circuit Low	Signal current > 24.0 mA
P2301	Ignition Coil A Primary Control Circuit High	Signal current > 5.1 - 7.0 mA
P2303	Ignition Coil B Primary Control Circuit Low	Signal current > 24.0 mA
P2304	Ignition Coil B Primary Control Circuit High	Signal current > 5.1 - 7.0 mA
P2306	Ignition Coil C Primary Control Circuit Low	Signal current > 24.0 mA
P2307	Ignition Coil C Primary Control Circuit High	Signal voltage > 5.1 - 7.0 mA
P2309	Ignition Coil D Primary Control Circuit Low	Signal current > 24.0 mA
P2310	Ignition Coil D Primary Control Circuit High	Signal voltage > 5.1 - 7.0 mA
P2312	Ignition Coil E Primary Control Circuit Low	Signal current > 24.0 mA
P2313	Ignition Coil E Primary Control Circuit High	Signal voltage > 5.1 - 7.0 mA
P2315	Ignition Coil F Primary Control Circuit Low	Signal current > 24.0 mA
P2316	Ignition Coil F Primary Control Circuit High	Signal voltage > 5.1 - 7.0 mA

## Additional Emissions Regulations

DTC	Error Message	Malfunction Criteria and Threshold Value
P240A	Evaporative Emission System Leak Detection Pump Heater Control Circuit/Open	Signal voltage > 4.7 to 5.4 V
P240B	Evaporative Emission System Leak Detection Pump Heater Control Circuit Low	Signal voltage < 2.74 to 3.26 V
P240C	Evaporative Emission System Leak Detection Pump Heater Control Circuit High	Signal current > 2.2 to 4 A

<b>DTC</b>	<b>Error Message</b>	<b>Malfunction Criteria and Threshold Value</b>
P2400	Evaporative Emission System Leak Detection Pump Control Circuit/Open	Signal voltage > 4.7 - 5.4 V
P2401	Evaporative Emission System Leak Detection Pump Control Circuit Low	Signal voltage < 2.74 to 3.26 V
P2402	Evaporative Emission System Leak Detection Pump Control Circuit High	<ul style="list-style-type: none"> <li>• Signal voltage at EVAP pump current measuring resistor &gt; 1.80 to 4 V</li> <li>or</li> <li>• Signal voltage at EVAP pump current measuring resistor &gt; 1.50 V</li> </ul>
P2407	Evaporative Emission System Leak Detection Pump Circuit Intermittent/Erratic	Fluctuation of EVAP pump current during reference measurement > 1 mA or drop of pump current during pump phase > 6 mA for $\geq 3$ Sec.
P2414	O2 Sensor Exhaust Sample Error (Bank 1, Sensor 1)	<ul style="list-style-type: none"> <li>• Threshold 1 - O2S signal front 3.70 to 4.81 V</li> <li>• Threshold 2 - Signal voltage 2.51 - 3.00 V Depending on gain factor that actual is used for the threshold is switched</li> </ul>
P2415	O2 Sensor Exhaust Sample Error (Bank 2 Sensor 1)	<ul style="list-style-type: none"> <li>• Threshold 1 - O2S signal front 3.70 to 4.81 V</li> <li>• Threshold 2 - Signal voltage 2.51 - 3.00 V Depending on gain factor that actual is used for the threshold is switched</li> </ul>
P2431	Secondary Air Injection System Air Flow/Pressure (Bank 1) Sensor Circuit Range/Performance	Difference between AIR pressure and ambient pressure NOT -60 to 60 hPa
P2432	Secondary Air Injection System Air Flow/Pressure Bank 1 Sensor Circuit Low	Signal voltage < 0.5 V
P2433	Secondary Air Injection System Air Flow/Pressure Bank 1 Sensor Circuit High	Signal voltage > 4.5 V
P2440	Secondary Air Injection System Switching Valve Stuck Open (Bank 1)	SAI pressure measured with SAI pressure sensor vs. modeled while SAI valve closed < 0.55%



<b>DTC</b>	<b>Error Message</b>	<b>Malfunction Criteria and Threshold Value</b>
P2442	Secondary Air Injection System Switching Valve Stuck Open (Bank 2)	AIR pressure measured with AIR pressure sensor vs. modeled with AIR valve closed < 71.9%
P2450	Evaporative Emission System Switching Valve Performance/ Stuck Open	EVAP pump current difference between reference measurement to idle ≤ 4 mA
P2539	Low Pressure Fuel System Sensor Circuit	Signal voltage > 4.80 V
P2540	Low Pressure Fuel System Sensor Circuit Range/ Performance	Actual pressure deviation < 800 kPa < 80 kPa
P2541	Low Pressure Fuel System Sensor Circuit Low	Signal voltage < 0.2 V
P2600	Coolant Pump "A" Control Circuit/Open	Signal voltage 4.8 to 5.3 V
P2602	Coolant Pump "A" Control Circuit Low	Signal voltage < 2.8 to 3.2 V
P2603	Coolant Pump "A" Control Circuit High	Signal current > 5.5 to 10 A
P261A	Coolant Pump "B" Control Circuit/Open	Signal voltage 4.8 to 5.3 V
P261C	Coolant Pump "B" Control Circuit Low	Signal voltage < 2.8 to 3.2 V
P261D	Coolant Pump "B" Control Circuit High	Signal current > 2.2 to 4 A
P2626	O2 Sensor Pumping Current Trim Circuit/Open (Bank 1 Sensor 1)	O2S signal front > 4.81 V
P2629	O2 Sensor Pumping Current Trim Circuit/Open Bank 1 Sensor 1	O2S signal front > 4.81 V
P2681	Engine Coolant Bypass Valve Control Circuit/Open	Signal voltage 4.8 to 5.3 V
P2682	Engine Coolant Bypass Valve Control Circuit Low	Signal voltage < 2.8 to 3.2 V
P2683	Engine Coolant Bypass Valve Control Circuit High	Signal current > 2.2 to 4 A

## Fuel and Air Mixture, Additional Emissions Regulations

DTC	Error Message	Malfunction Criteria and Threshold Value
P305C	Intake Air Temperature Sensor 2 Circuit Low	Intake air temperature > 128 °C
P305D	Intake Air Temperature Sensor 2 Circuit High	Intake air temperature < -39 °C
P305E	Intake Air Temperature Sensor 2 Range/Performance	<ul style="list-style-type: none"> <li>• Downstream IAT vs ECT &gt; 26 or ≤ -26 °C</li> <li>or</li> <li>• Downstream IAT vs IAT after intercooler 1 &gt; 26 or ≤ -26 °C</li> </ul>
P308D	Fuel Pump Speed Too Low	Phase current > 35 A or speed deviation > 10%
P308E	Fuel Pump Electronics Excess Temperature	Power stage temperature > 126 to 129 °C
P3081	Engine Temperature Too Low	Difference between modeled and actual ECT > 9.8 K
P309C	Clutch Disengagement Actuator Mechanical Malfunction	Actuator hardware failure or actuator voltage failure
P309D	Clutch Disengagement Actuator Insufficient Slip with Disengaged Clutch	Combustion engine speed is detected while electronic clutch is open > 25 RPM
P309F	Clutch Disengagement Actuator Slip when Clutch Engaged	Difference between combustion engine speed and electric machine speed > 200 to 300 RPM

# DTC CHART

## Engine Code - CGRA

### Fuel and Air Mixture, Additional Emissions Regulations

DTC	Error Message	Malfunction Criteria and Threshold Value
P000A	Intake (A) Camshaft Position Slow Response (Bank 1)	Difference between target and actual position > 12 to 40 ° CRK for > 3 Sec. and Adjustment angle $\geq 3^\circ$ CRK
P000B	"B" Camshaft Position Slow Response (Bank 1)	Difference between target and actual position > 10 to 22 ° CRK for > 2 to 3 Sec. and Adjustment angle $\geq 3^\circ$ CRK
P0010	Intake (A) Camshaft Position Actuator Circuit/Open (Bank 1)	Signal voltage > 4.7 - 5.4 V
P0011	Intake (A) Camshaft Position Timing - Over-Advanced (Bank 1)	Difference between target and actual position > 12 to 40 ° CRK for > 3 Sec. and Adjustment angle < 3° CRK
P0013	B Camshaft Position Actuator Circuit/Open (Bank 1)	Signal voltage, > 4.7 - 5.4 V
P0014	B Camshaft Position (Bank 1) Timing Over-Advanced or System Performance	Difference between target and actual position > 10 to 22 ° CRK for > 3 Sec. and Adjustment angle < 3 °CRK
P0016	Crankshaft Position - Camshaft Position Correlation (Bank 1, Sensor A)	Deviation in camshaft position to crankshaft position > 11.01 or < -11.01 degrees of crank rotation
P0017	Crankshaft Position-Camshaft Position Correlation (Bank 1 Sensor B)	Deviation in camshaft position to crankshaft position > 11.01 or < -11.01 degrees of crank rotation
P0030	HO2S Heater Control Circuit (Bank 1, Sensor 1) Open Circuit	Heater voltage 4.70 - 5.40 V
P0031	HO2S Heater Control Circuit Low (Bank 1, Sensor 1) Short to Ground	Heater voltage 0.0 to 3.26 V

<b>DTC</b>	<b>Error Message</b>	<b>Malfunction Criteria and Threshold Value</b>
P0032	HO2S Heater Control Circuit High (Bank 1, Sensor 1) Short to B+	Heater current > 5.50 A
P0036	HO2S Heater Control Circuit (Bank 1, Sensor 2) Open Circuit	Heater voltage 2.34 V
P0037	HO2S Heater Control Circuit Low (Bank 1, Sensor 2) Short to Ground	Heater voltage < 3.00 V
P0038	HO2S Heater Control Circuit High (Bank 1, Sensor 2) Short to B+	Heater current 2.70 - 5.50 A
P0040	O2 Sensor Signals Swapped (Bank 1 Sensor 1/ Bank 2 Sensor 1)	Lambda controllers exceed thresholds in opposite directions > 1.20
P0050	O2 Sensor Heater Control Circuit (Bank 2 Sensor 1)	Heater voltage 4.70 - 5.40 V
P0051	O2 Sensor Heater Control Circuit (Bank 2 Sensor 1) Low	Heater voltage 0.0 to 3.26 V
P0052	O2 Sensor Heater Control Circuit (Bank 2 Sensor 1) High	Heater current > 5.50 A
P0056	O2 Sensor Heater Control Circuit (Bank 2 Sensor 2)	Heater voltage 2.34 - 3.59 V
P0057	O2 Sensor Heater Control Circuit (Bank 2 Sensor 2) Low	Heater voltage < 2.34 V
P0058	O2 Sensor Heater Control Circuit (Bank 2 Sensor 2) High	Heater voltage 3.59 V
P0068	MAF – Throttle Position Correlation	<ul style="list-style-type: none"> <li>• Plausibility with fuel system load calculation &lt; -35%</li> <li>• Plausibility with fuel system load calculation &gt; 35%</li> </ul>
P0070	Ambient Air Temperature Sensor Circuit	Ambient air temperature < -50 °C
P0071	Ambient Air Temperature Sensor Range/Performance	<ul style="list-style-type: none"> <li>• Difference in value between ECT and AAT at engine start (depending on engine off time) &lt; 24.8 Kelvin</li> <li>and</li> <li>• Difference in value between AAT and IAT at engine start (depending on engine off time) &gt; 24.8 Kelvin</li> </ul>

DTC	Error Message	Malfunction Criteria and Threshold Value
P0072	Ambient Air Temperature Sensor Circuit Low	Ambient air temperature > 87 °C
P008A	Low Pressure Fuel System Pressure - Too Low	Actual pressure < 40 kPa
P008B	Low Pressure Fuel System Pressure - Too High	Actual pressure > 780 kPa
P0087	Fuel Rail/System Pressure - Too Low	<ul style="list-style-type: none"> <li>• Fuel trim activity 0.80 to 1.20</li> <li>• Pressure control activity &gt; 2.20 MPa</li> </ul>
P0089	Fuel Pressure Regulator 1 Performance	<ul style="list-style-type: none"> <li>• Difference between target vs. actual pressure &gt; 150 kPa or actual vs target pressure &gt; 200 kPa</li> <li>• Feedback control loop &lt; -300 or &gt; 225 kPa</li> </ul>
P0100	Mass or Volume Air Flow A Circuit	<ul style="list-style-type: none"> <li>• MAF sensor signal 0 <math>\mu</math>s</li> <li>• MAF signal temp correction &lt; 40 mSec.</li> <li>• MAF signal temp correction &lt; 40 and &gt; 65 mSec.</li> </ul>
P0101	Mass or Volume Air Flow A Circuit Range/Performance	<ul style="list-style-type: none"> <li>• Air mass too low &lt; -10 kg/h</li> <li>• Air mass too high &gt; 1100 kg/hh</li> <li>• Mass air flow vs lower threshold model &lt; 0 to 580 kg/h</li> <li>• Load calculation &gt; 20% and fuel trim &lt; -20% or load calculation &lt; -20% fuel trim &gt; 20%</li> </ul>
P0102	Mass or Volume Air Flow A Circuit Low Input	MAF sensor signal < 66 $\mu$ s or MAF sensor signal temp correction < 40 mSec.
P0103	Mass or Volume Air Flow A Circuit High Input	MAF sensor signal > 910 $\mu$ s or MAF sensor signal temp correction > 65 mSec.
P0111	Intake Air Temperature (Sensor 1 Bank 1) Circuit Range/Performance	<ul style="list-style-type: none"> <li>• Difference of ECT vs. IAT at engine start &lt; 24.8 Kelvin</li> <li>• Difference of IAT vs. AAT at engine start &gt; 24.8 Kelvin</li> <li>• Difference of ECT vs. AAT at engine start &lt; 24.8 Kelvin</li> </ul>
P0112	Intake Air Temperature (Sensor 1 Bank 1) Circuit Low	Intake air temperature > 130°C

DTC	Error Message	Malfunction Criteria and Threshold Value
P0113	Intake Air Temperature (Sensor 1 Bank 1) Circuit High	Intake air temperature < -45 °C
P0116	Engine Coolant Temperature Sensor 1 Circuit Range/Performance	<ul style="list-style-type: none"> <li>• Difference in value between ECT and IAT at engine start (depending on engine off time) &gt; 24.8 Kelvin</li> <li>• No change on signal, threshold - 2 Kelvin</li> </ul> or <ul style="list-style-type: none"> <li>• Signal in range 80 - 105 °C and no change on signal 1.5 K</li> </ul>
P0117	Engine Coolant Temperature Sensor 1 Circuit Low Input	Engine coolant temperature > 137 °C
P0118	Engine Coolant Temperature Sensor 1 Circuit High Input	Engine coolant temperature < -44°C
P0121	Throttle/Pedal Position Sensor A Circuit Range/Performance	<ul style="list-style-type: none"> <li>• TPS 1 - TPS 2 &gt; 5.10 to 6.30%</li> <li>• Actual TPS 1 calculated value &gt; TPS 2 calculated value</li> </ul> or <ul style="list-style-type: none"> <li>• TPS 2 calculated value &gt; 9%</li> </ul>
P0122	Throttle/Pedal Position Sensor A Circuit Low Input	Signal voltage < 0.20 V
P0123	Throttle/Pedal Position Sensor A Circuit High Input	Signal voltage > 4.81 V
P013A	O2 Sensor Bank 1 Sensor 2 Slow Response Rich to Lean	EWMA filtered max differential transient time at fuel cutoff ≥ 0.5 Sec. and number of checks ≥ 2
P013C	O2 Sensor Bank 2 Sensor 2 Slow Response Rich to Lean	EWMA filtered max differential transient time at fuel cutoff ≥ 0.5 Sec. and number of checks ≥ 2
P0130	O2 Sensor Circuit (Bank 1, Sensor 1)	O2S ceramic temperature < 640°C
P0131	O2 Sensor Circuit (Bank 1, Sensor 1) Low Voltage	Virtual mass < 1.75 V
		Nernst voltage < 1.50 V
		Adjustment voltage < 0.30 V
P0132	O2 Sensor Circuit (Bank 1, Sensor 1) High Voltage	Virtual mass > 3.25 V
		Nernst voltage > 4.40 V
		Adjustment voltage > 7 V

DTC	Error Message	Malfunction Criteria and Threshold Value
P0133	O2 Circuit Slow Response (Bank 1, Sensor 1)	<ul style="list-style-type: none"> <li>• O2S signal front vs. modeled O2S signal ratio &lt; 0.30</li> <li>or</li> <li>• O2S signal front vs. modeled O2S signal in case error suspected catalyst &lt; 0.40</li> <li>• Cycles completed <math>\geq 7</math></li> </ul>
P0135	O2 Heater Sensor Circuit (Bank 1, Sensor 1) Malfunction	<ul style="list-style-type: none"> <li>• Heater duty cycle &gt; 90%</li> <li>• O2S ceramic temperature, &lt; 685 °C</li> <li>or</li> <li>• O2S ceramic temp &lt; 720 °C</li> <li>• Time after O2S heater on 40 Sec</li> </ul>
P0136	O2 Sensor Circuit (Bank 1, Sensor 2) Malfunction	<ul style="list-style-type: none"> <li>• Delta voltage one step at heater switching &gt; 2.00 V</li> <li>• Number of checks 4</li> </ul>
P0137	O2 Circuit (Bank 1, Sensor 2) Low Voltage	<p>Cold condition</p> <ul style="list-style-type: none"> <li>• gnal voltage, &lt; 40 mV</li> </ul> <p>Warm condition</p> <ul style="list-style-type: none"> <li>• Signal voltage &lt; 40 mv</li> <li>• Reaction at closed loop enrichment - no reaction</li> </ul>
P0138	O2 Circuit (Bank 1, Sensor 2) High Voltage	Signal voltage > 1.08 V for 5 Sec.
P0139	O2 Circuit (Bank 1 Sensor 2) Slow Response	<ul style="list-style-type: none"> <li>• EWMA filtered transient time at fuel cutoff &gt; 0.5 Sec.</li> <li>• In voltage range 200 - 400 mV</li> <li>• Number of checks <math>\geq 3</math></li> </ul>
P0140	O2 Sensor Circuit (Bank 1 Sensor 2) No Activity Detected	<p>Signal voltage</p> <ul style="list-style-type: none"> <li>• Signal voltage 0.40 - 0.60 V for 3 Sec.</li> <li>• Reaction at closed loop enrichment = no reaction</li> </ul> <p>Internal resistance</p> <ul style="list-style-type: none"> <li>• &gt; 105,000 ohm</li> </ul>
P0141	O2 Sensor Heater Circuit (Bank 1 Sensor 2) Malfunction	Heater resistance Heater resistance, 728 - 16632 Ohm
P0150	O2 Sensor Circuit (Bank 2 Sensor 1) Malfunction	O2S ceramic temperature < 640 °C
P0151	O2 Sensor Circuit (Bank 2 Sensor 1) Low Voltage	Virtual mass < 1.75 V
		Nernst voltage < 1.50 V
		Adjustment voltage < 0.30 V

<b>DTC</b>	<b>Error Message</b>	<b>Malfunction Criteria and Threshold Value</b>
P0152	O2 Sensor Circuit (Bank 2 Sensor 1) High Voltage	Virtual mass > 3.25 V
		Nernst voltage > 4.40 V
		Adjustment voltage > 7 V
P0153	O2 Sensor Circuit (Bank 2 Sensor 1) Slow Response	<ul style="list-style-type: none"> <li>• O2S signal front vs. modeled O2S signal ratio &lt; 0.30</li> <li>or</li> <li>• O2S signal front vs. modeled O2S signal in case error suspected catalyst &lt; 0.40</li> <li>• Cycles completed <math>\geq</math> 3</li> </ul>
P0155	O2 Sensor Heater Circuit (Bank 2 Sensor 1) Malfunction	<ul style="list-style-type: none"> <li>• Heater duty cycle &gt; 90%</li> <li>• O2S ceramic temperature, &lt; 685 °C</li> <li>or</li> <li>• O2S ceramic temp &lt; 720 °C</li> <li>• Time after O2S heater on 40 Sec.</li> </ul>
P0156	O2 Sensor Circuit (Bank 2 Sensor 2) Malfunction	<ul style="list-style-type: none"> <li>• Delta voltage one step at heater switching &gt; 2.00 V</li> <li>• Number of checks 4</li> </ul>
P0157	O2 Sensor Circuit (Bank 2 Sensor 2) Low Voltage	<p>Cold condition</p> <ul style="list-style-type: none"> <li>• Signal voltage, &lt; 40 mV</li> </ul> <p>Warm condition</p> <ul style="list-style-type: none"> <li>• Signal voltage &lt; 40 mv</li> <li>• Reaction at closed loop enrichment - no reaction</li> </ul>
P0158	O2 Sensor Circuit (Bank 2 Sensor 2) High Voltage	Signal voltage > 1.08 V for 5 Sec.
P0159	O2 Sensor Circuit (Bank 2 Sensor 2) Slow Response	<ul style="list-style-type: none"> <li>• EWMA filtered transient time at fuel cutoff &gt; 0.5 Sec.</li> <li>• In voltage range 200 - 400 mV</li> <li>• Number of checks <math>\geq</math> 3</li> </ul>
P0160	O2 Sensor Circuit (Bank 2 Sensor 2) No Activity Detected	<p>Signal voltage</p> <ul style="list-style-type: none"> <li>• Signal voltage 0.40 - 0.60 V for 3 Sec.</li> <li>• Reaction at closed loop enrichment = no reaction</li> </ul> <p>Internal resistance</p> <ul style="list-style-type: none"> <li>• &gt; 105,000 ohm</li> </ul>
P0161	O2 Sensor Heater Circuit (Bank 2 Sensor 2) Malfunction	Heater resistance, 728 - 16632 Ohm



<b>DTC</b>	<b>Error Message</b>	<b>Malfunction Criteria and Threshold Value</b>
P0169	Incorrect Fuel Composition	Fuel quantity incorrect or Difference between calculated and actual air mass > 10.5%
P017B	Cylinder Head Temperature Sensor Circuit Range/ Performance	Difference between modeled and measured cylinder head temperature > 9.8 Kelvin or Difference between cyl head temp sensor and ECT $\geq$ 24.8 Kelvin
P017C	Cylinder Head Temperature Sensor Circuit Low	Signal voltage < 0.30 V
P017D	Cylinder Head Temperature Sensor Circuit High	Signal voltage > 4.90 V
P0171	System Too Lean (Bank 1)	At idle • Adaptive value > 5.02% At part-load • Adaptive value > 21%
P0172	System Too Rich (Bank 1)	At idle • Adaptive value < 5.02% At part-load • Adaptive value < 21%
P0190	Fuel Rail Pressure Sensor A Circuit	Signal voltage > 4.8 V
P0191	Fuel Rail Pressure Sensor "A" Circuit Range/Performance	Actual pressure > 14.60 MPa or < 0.005 MPa
P0192	Fuel Rail Pressure Sensor "A" Circuit Low Input	Signal voltage < 0.20 V
P0201	Injector Circuit/Open - Cylinder 1	• Low side signal current < 2.1 A • Internal logic failure
P0202	Injector Circuit/Open - Cylinder 2	• Low side signal current < 2.1 A • Internal logic failure
P0203	Injector Circuit/Open - Cylinder 3	• Low side signal current < 2.1 A • Internal logic failure
P0204	Injector Circuit/Open - Cylinder 4	• Low side signal current < 2.1 A • Internal logic failure
P0205	Injector Circuit/Open - Cylinder 5	• Low side signal current < 2.1 A • Internal logic failure
P0206	Injector Circuit/Open - Cylinder 6	• Low side signal current < 2.1 A • Internal logic failure

<b>DTC</b>	<b>Error Message</b>	<b>Malfunction Criteria and Threshold Value</b>
P0221	Throttle/Pedal Position Sensor/Switch B Circuit Range/Performance	<ul style="list-style-type: none"> <li>• TPS 1 - TPS 2 &gt; 5.10 - 6.30% and</li> <li>• Actual TPS 2 calculated value &gt; actual TPS 1 calculated value</li> </ul> or <ul style="list-style-type: none"> <li>• TPS 2 calculated value &gt; 9.00%</li> </ul>
P0222	Throttle/Pedal Position Sensor/Switch B Circuit Low Input	Signal voltage < 0.20 V
P0223	Throttle/Pedal Position Sensor/Switch B Circuit High Input	Signal voltage > 4.81 V
P025A	Fuel Pump Module Control Circuit/Open	Signal voltage > 4.4 - 5.6 V
P025C	Fuel Pump Module Control Circuit Low	Signal voltage < 2.15 - 3.25 V
P025D	Fuel Pump Module Control Circuit High	Signal current > 1.1 A
P0261	Cylinder 1 Injector Circuit Low	Signal current < 2.10 A
P0262	Cylinder 1 Injector Circuit High	Signal current > 14.70 A
P0264	Cylinder 2 Injector Circuit Low	Signal current < 2.10 A
P0265	Cylinder 2 Injector Circuit High	Signal current > 14.70 A
P0267	Cylinder 3 Injector Circuit Low	Signal current < 2.10 A
P0268	Cylinder 3 Injector Circuit High	Signal current > 14.70 A
P0270	Cylinder 4 Injector Circuit Low	Low side signal current < 2.10 A
P0271	Cylinder 4 Injector Circuit High	Signal current > 14.70 A
P0273	Cylinder 5 Injector Circuit Low	Low side signal current < 2.10 A
P0274	Cylinder 5 Injector Circuit High	Signal current > 14.70 A
P0276	Cylinder 6 Injector Circuit Low	Low side signal current < 2.10 A
P0277	Cylinder 6 Injector Circuit High	Signal current > 14.70 A
P2088	"A" Camshaft Position Actuator Control Circuit Low - Bank 1	Signal voltage 0.0 - 3.25 V
P2089	"A" Camshaft Position Actuator Control Circuit High - Bank 1	Signal current > 2.2 A
P2090	B Camshaft Position Actuator Control Circuit (Bank 1) Low	Signal voltage 0 to 3.25 V

DTC	Error Message	Malfunction Criteria and Threshold Value
P2091	B Camshaft Position Actuator Control Circuit (Bank 1) High	Signal current > 2.20 A
P2096	Post-Catalyst Fuel Trim System (Bank 1 Too Lean (Bank 1)	I-portion of 2nd lambda control loop < -0.035
P2097	Post-Catalyst Fuel Trim System (Bank 1) Too Rich	I-portion of 2nd lambda control loop > 0.035
P2098	Post Catalyst Fuel Trim System (Bank 2) Too Lean	I-portion of 2nd lambda control loop < -0.035
P2099	Post Catalyst Fuel Trim System (Bank 2) Too Rich	I-portion of 2nd lambda control loop > 0.035
P3081	Engine Temperature Too Low	Difference between ECT and modeled ECT > 11.3 °K
P308D	Fuel Pump Engine Speed Too Low	Phase current > 35 A or Speed deviation > 10%
P308E	Fuel Pump Electronics Excess Temperature	Output driver temp > 126 °C or above 129 °C

## Ignition System

DTC	Error Message	Malfunction Criteria and Threshold Value
P0300	Random/Multiple Cylinder Misfire Detected	<ul style="list-style-type: none"> <li>Emission threshold misfire rate (MR) &gt; 2.2%</li> <li>Catalyst damage misfire rate (MR) &gt; 1.05 - 13.33%</li> </ul>
P0301	Cylinder 1 Misfire Detected	<ul style="list-style-type: none"> <li>Emission threshold misfire rate (MR) &gt; 2.2%</li> <li>Catalyst damage misfire rate (MR) &gt; 1.05 - 13.33%</li> </ul>
P0302	Cylinder 2 Misfire Detected	<ul style="list-style-type: none"> <li>Emission threshold misfire rate (MR) &gt; 2.2%</li> <li>Catalyst damage misfire rate (MR) &gt; 1.05 - 13.33%</li> </ul>
P0303	Cylinder 3 Misfire Detected	<ul style="list-style-type: none"> <li>Emission threshold misfire rate (MR) &gt; 2.2%</li> <li>Catalyst damage misfire rate (MR) &gt; 1.05 - 13.33%</li> </ul>
P0304	Cylinder 4 Misfire Detected	<ul style="list-style-type: none"> <li>Emission threshold misfire rate (MR) &gt; 2.2%</li> <li>Catalyst damage misfire rate (MR) &gt; 1.05 - 13.33%</li> </ul>

<b>DTC</b>	<b>Error Message</b>	<b>Malfunction Criteria and Threshold Value</b>
P0305	Cylinder 5 Misfire Detected	<ul style="list-style-type: none"> <li>• Emission threshold misfire rate (MR) &gt; 2.2%</li> <li>• Catalyst damage misfire rate (MR) &gt; 1.05 - 13.33%</li> </ul>
P0306	Cylinder 6 Misfire Detected	<ul style="list-style-type: none"> <li>• Emission threshold misfire rate (MR) &gt; 1.7%</li> <li>• Catalyst damage misfire rate (MR) &gt; 5.0 - 20.0%</li> </ul>
P0321	Ignition/Distributor Engine Speed Input Circuit Range/ Performance	<ul style="list-style-type: none"> <li>• Comparison of counted teeth vs reference incorrect</li> <li>• missing reference mark within 720 CRK rev. 2 consecutive times</li> <li>• Camshaft signals &gt; 8 and no engine speed signal.</li> </ul>
P0322	Ignition/Distributor Engine Speed Input Circuit No Signal	<ul style="list-style-type: none"> <li>• Camshaft signal &gt; 3</li> <li>• Engine speed no signal</li> </ul>
P0324	Knock Control System Error	<ul style="list-style-type: none"> <li>• Signal fault counter &gt; 28 or</li> <li>• Sensor signal failed</li> </ul>
P0325	Knock Sensor 1 Circuit Malfunction	Signal voltage < 1.80 V or > 3.20 V
P0327	Knock Sensor 1 Circuit Low Input	Lower threshold 0.30 to 2.50 V OR short to ground lower threshold < -0.70 V
P0328	Knock Sensor 1 Circuit High Input	Upper threshold 36 to 110.15 V or short to voltage upper threshold > 1 V
P0330	Knock Sensor 2 Circuit	Signal voltage < 1.80 V or > 3.20 V
P0332	Knock Sensor 2 Circuit Low Input	Lower threshold 0.30 to 2.50 V or short to ground lower threshold < -70 V
P0333	Knock Sensor 2 Circuit High Input	Upper threshold 36 to 110.15 V or short to voltage upper threshold > 1 V
P0340	Camshaft Position Sensor Circuit	Cam adaption values out of range <ul style="list-style-type: none"> <li>• &gt; 20° KW</li> <li>• &lt; -20° KW</li> <li>• Difference of adapted and actual values &gt; 9° KW</li> </ul>

<b>DTC</b>	<b>Error Message</b>	<b>Malfunction Criteria and Threshold Value</b>
P0341	Camshaft Position Sensor Circuit Range/Performance	<ul style="list-style-type: none"> <li>• Signal pattern incorrect or not alternating</li> <li>• Defect counter &gt; 12</li> </ul>
P0342	Camshaft Position Sensor 1 Circuit Low Input	<ul style="list-style-type: none"> <li>• Signal voltage low</li> <li>• Crankshaft signals = 8 revolutions</li> </ul>
P0343	Camshaft Position Sensor A Circuit High Input	<ul style="list-style-type: none"> <li>• Signal voltage high</li> <li>• Crankshaft signals = 8 revolutions</li> </ul>
P0351	Ignition Coil A Primary/ Secondary Circuit	<ul style="list-style-type: none"> <li>• Signal current 0.25 to -2.0 mA</li> <li>• Internal check failed</li> </ul>
P0352	Ignition Coil B Primary/ Secondary Circuit	<ul style="list-style-type: none"> <li>• Signal current 0.25 to -2.0 mA</li> <li>• Internal check failed</li> </ul>
P0353	Ignition Coil C Primary/ Secondary Circuit	<ul style="list-style-type: none"> <li>• Signal current 0.25 to -2.0 mA</li> <li>• Internal check failed</li> </ul>
P0354	Ignition Coil D Primary/ Secondary Circuit	<ul style="list-style-type: none"> <li>• Signal current 0.25 to -2.0 mA</li> <li>• Internal check failed</li> </ul>
P0355	Ignition Coil E Primary/ Secondary Circuit	<ul style="list-style-type: none"> <li>• Signal current 0.25 to -2.0 mA</li> <li>• Internal check failed</li> </ul>
P0356	Ignition Coil F Primary/ Secondary Circuit	<ul style="list-style-type: none"> <li>• Signal current 0.25 to -2.0 mA</li> <li>• Internal check failed</li> </ul>
P0366	Camshaft Pos.Sensor "B" Circuit (Bank 1) Range/ Performance	<ul style="list-style-type: none"> <li>• Signal voltage not alternating</li> <li>• Crankshaft signals = 12 revolutions</li> </ul>
P0367	Camshaft Pos.Sensor "B" Circuit (Bank 1) Low Input	<ul style="list-style-type: none"> <li>• Signal voltage low</li> <li>• Crankshaft signals = 8 revolutions</li> </ul>
P0368	Camshaft Pos.Sensor "B" Circuit (Bank 1) High Input	<ul style="list-style-type: none"> <li>• Signal voltage high</li> <li>• Crankshaft signals = 8 revolutions</li> </ul>

## Additional Exhaust Regulation

DTC	Error Message	Malfunction Criteria and Threshold Value
P0420/ P0430	Catalyst System Bank 1 (P0420) or Bank 2 (P0430) Efficiency Below Threshold	<ul style="list-style-type: none"> <li>• Measured oxygen storage capacity (OSC) &lt; 1.00 HC correlated</li> <li>• Measured oxygen storage capacity (OSC) catalyst system &lt; 1.00 NOx correlated</li> </ul>
P0441	Evaporative Emission System Incorrect Purge Flow	Deviation lambda controller < 5.0% and range lambda control < 20%
P0442	Evaporative Emission System Leak Detected (Small Leak)	Time for pressure drop < 1.70 - 1.90 Sec.
P0444	Evaporative Emission System Purge Control Valve Circuit Open	Signal voltage > 4.70 - 5.40 V
P0455	Evaporative Emission System Leak Detected (Gross Leak/ No Flow)	Time for pressure drop < 0.9 - 1.2 Sec.
P0456	Evaporative Emission System Leak Detected (Very Small Leak)	Time for pressure drop, < 6.5 - 7.0 Sec..
P0458	Evaporative Emission System Purge Control Valve Circuit Low	Signal voltage 0 to 3.26 V
P0459	Evaporative Emission System Purge Control Valve Circuit High	Signal current > 2.20 A
P0480	Cooling Fan 1 Control Circuit	Signal voltage 4.50 to 5.50 V
P0481	Cooling Fan 2 Control Circuit	Signal voltage 4.50 to 5.50 V

## Speed and Idle Control

DTC	Error Message	Malfunction Criteria and Threshold Value
P050A	Cold Start Idle Air Control System Performance	<ul style="list-style-type: none"> <li>• Engine speed deviation &lt; -100 RPM</li> <li>• Idle controller at max value 8% or</li> <li>• Engine speed deviation &gt; 200 RPM</li> <li>• Idle controller at min value -4.98%</li> </ul>

<b>DTC</b>	<b>Error Message</b>	<b>Malfunction Criteria and Threshold Value</b>
P050B	Cold Start Ignition Timing Performance	Difference between commanded vs actual spark timing > 20%
P0501	Vehicle Speed Sensor A Range/Performance	VSS signal < 4 km/h
P0506	Idle Air Control System - RPM Lower Than Expected	Engine speed deviation > 100 RPM and Idle controller torque value $\geq$ calculated max value
P0507	Idle Air Control System - RPM Higher Than Expected	Engine speed Deviation < -100 RPM and Idle controller torque value $\leq$ calculated max value
P052A	Cold Start "A" Camshaft Position Timing Over-Advanced	Difference between target vs. actual position and position > 12 to 40 °CRK
P053F	Cold Start Fuel Pressure Performance	Difference between target vs actual pressure < -1.50 or > 1.50 MPa
P054A	Cold Start "B" Camshaft Position Timing Over-Advanced	Difference between target vs. actual position and position > 10 to 22 °CRK

### **Control Module and Output Signals**

<b>DTC</b>	<b>Error Message</b>	<b>Malfunction Criteria and Threshold Value</b>
P0601	Internal Control Module Memory Check Sum Error	ECM internal checksum incorrect
P0604	Internal Control Module Random Access Memory (RAM) Error	Write ability check, failed
P0605	Internal Control Module Read Only Memory (ROM) Error	ROM check failed
P0606	ECM Processor	ECM internal check failure
P062B	Internal Control Module Fuel Injector Control Performance	Internal logic failure
P0634	ECM Internal Temperature Too High	Power stage (coolant pump driver) Temperature > 170 °C

<b>DTC</b>	<b>Error Message</b>	<b>Malfunction Criteria and Threshold Value</b>
P0638	Throttle Actuator Control (Bank1) Range/Performance	<ul style="list-style-type: none"> <li>• Time to close to reference point &gt; 0.6 Sec.</li> <li>• ECM power stage no failure or</li> <li>• TPS 1 signal voltage NOT 0.4 to 0.8 V</li> <li>• TPS 2 signal voltage NOT 4.20 to 4.60 V</li> <li>• TPS 1 + TPS 2 NOT 4.82 to 5.18</li> </ul>
P0641	Sensor Reference Voltage A Circuit/Open	Internal communication failed or signal voltage deviation > +/- 0.3 V
P0642	Sensor Reference Voltage A Circuit Low	Signal voltage < 4.60 5.00 V
P0643	Sensor Reference Voltage A Circuit High	Signal voltage, > 5.00 to 5.40 V
P0651	Sensor Reference Voltage B Circuit/Open	Internal communication failed or signal voltage deviation > +/- 0.3 V
P0652	Sensor Reference Voltage B Circuit Low	Signal voltage < 4.6 - 5.0 V
P0653	Sensor Reference Voltage B Circuit High	Signal voltage > 5.00 to 5.40 V
P0657	Actuator Supply Voltage A Circuit/Open	Signal voltage, > 4.4 - 5.6 V
P0658	Actuator Supply Voltage A Circuit Low	Signal voltage, < 3.00 V
P0659	Actuator Supply Voltage A Circuit High	Signal current > 1.1 A
P0685	ECM Power Relay Control Circuit/Open	Control voltage > 0.7 V
P0686	ECM Power Relay Control Circuit Low	Control voltage < 0.51 V
P0687	ECM Power Relay Control Circuit High	Control voltage > 4.0 V
P0688	ECM Power Relay Sense Circuit	Sense voltage < 3.0 V
P0691	Cooling Fan 1 Control Circuit Low	Signal voltage < 3 V
P0692	Cooling Fan 1 Control Circuit High	Signal current, 0.60 to 1.20 A



<b>DTC</b>	<b>Error Message</b>	<b>Malfunction Criteria and Threshold Value</b>
P0693	Cooling Fan 2 Control Circuit Low	Signal voltage < 3 V
P0694	Cooling Fan 2 Control Circuit High	Signal current, 0.60 to 1.20 A
P0697	Sensor Reference Voltage C Circuit/Open	Internal communication failed or signal voltage deviation > +/- 0.3 V
P0698	Sensor Reference Voltage C Circuit Low	Signal voltage < 4.60 to 5.00 V
P0699	Sensor Reference Voltage C Circuit High	Signal voltage > 5.00 to 5.40 V
U0001	High Speed CAN Communication Bus	CAN message, no feedback
U0002	High Speed CAN Communication Bus	Global Time Out failure. No module communication on CAN.
U0101	Lost Communication with TCM	Time Out failure. No message received by ECM from TCM
U0121	Lost Communication With Anti-Lock Brake System (ABS) Control Module	CAN communication with ABS, time out
U0140	Lost Communication With Body Control Module	CAN communication with BCM timed out.
U0141	Lost Communication With Body Control Module "A"	CAN communication with BCM timed out.
U0146	Lost Communication With Gateway "A"	CAN communication with gateway, time out
U0155	Lost Communication With Instrument Panel Cluster (IPC) Control Module	CAN communication with IPC timed out.
U0302	Software Incompatibility with Transmission Control Module	AT vehicle ECM coded as MT vehicle
U0402	Invalid Data Received From Transmission Control Module	Transmission Data Length Code incorrect or invalid information from TCM.
U0415	Invalid Data Received From Anti-Lock Brake System Control Module	<ul style="list-style-type: none"> <li>• Speed sensor initialization failed</li> <li>• Speed sensor low voltage error failed</li> <li>• Speed sensor error &gt; 325 km/h</li> </ul>
U0422	Invalid Data Received From Body Control Module	Ambient air temperature value 00h

<b>DTC</b>	<b>Error Message</b>	<b>Malfunction Criteria and Threshold Value</b>
U0423	Invalid Data Received From Instrument Panel Cluster Control Module	CAN message incorrect.
U0447	Invalid Data Received From Gateway "A"	Implausible messages received
U1103	Production Mode Active	Production Mode active

### **Fuel and Air Ratios Control Module**

<b>DTC</b>	<b>Error Message</b>	<b>Malfunction Criteria and Threshold Value</b>
P12A1	Fuel Rail Pressure Sensor inappropriately low	<ul style="list-style-type: none"> <li>• Pressure control activity &gt; 0.09 MPa</li> <li>• Fuel trim activity &lt; 0.75</li> </ul>
P12A2	Fuel Rail Pressure Sensor Inappropriately High	<ul style="list-style-type: none"> <li>• Pressure control activity &lt; -0.11 MPa</li> <li>• Fuel trim activity &gt; 1.30</li> </ul>
P12A4	Fuel Rail Pump Control Valve Stuck Closed	<ul style="list-style-type: none"> <li>• Fuel trim activity .80 to 1.20</li> <li>• Pressure control activity &lt; -4.0 MPa</li> </ul>
P13EA	Cold Start Ignition Timing Performance Off Idle	Difference between commanded vs actual spark timing > 20%
P150A	Engine Off Time Performance	<ul style="list-style-type: none"> <li>• Difference between engine off time and ECM after run time &lt; -8 Sec.</li> <li>or</li> <li>• Difference between engine off time and ECM after run time &gt; 8 Sec.</li> </ul>
P169A	Loading Mode Active	Transport mode active
P2101	Throttle Actuator A Control Motor Circuit Range/ Performance	<ul style="list-style-type: none"> <li>• Duty cycle &gt;80% and</li> <li>• ECM power stage, no failure or</li> <li>• Deviation throttle valve angles vs. calculated value 4.0 - 50.0%</li> </ul>
P2106	Throttle Actuator Control System Forced Limited Power	Internal check failed
P2108	Throttle Actuator Control Module Performance	Time to close under reference point > 0.60 Sec. and reference point 11.56%

DTC	Error Message	Malfunction Criteria and Threshold Value
P2122	Throttle/Pedal Position Sensor/Switch D Circuit Low Input	Signal voltage < 0.65 V
P2123	Throttle/Pedal Position Sensor/Switch D Circuit High Input	Signal voltage > 4.89 V
P2127	Throttle/Pedal Position Sensor/Switch E Circuit Low Input	Signal voltage < 0.28 V
P2128	Throttle/Pedal Position Sensor/Switch E Circuit High Input	Signal voltage > 2.64 V
P2138	Throttle/Pedal Position Sensor/Switch D/E Voltage Correlation	Signal voltage sensor 1 vs. 2 > 0.14 to 0.26 V
P2146	Fuel Injector Group A Supply Voltage Circuit/Open	High side signal current > 14.90 A • Signal current > 14.90 A or • High side signal current < 2.60 A
P2149	Fuel Injector Group B Supply Voltage Circuit/Open	• High side signal current > 14.90 A or • High side signal current < 2.60 A
P2152	Fuel Injector Group C Supply Voltage Circuit Open	• High side signal current > 14.90 A or • High side signal current < 2.60 A
P2155	Fuel Injector Group D Supply Voltage Circuit Open	• High side signal current > 14.90 A or • High side signal current < 2.60 A
P2177	System Too Lean Off Idle, Bank 1	Fuel adaptive value > 30%
P2178	System Too Rich Off Idle, Bank 1	Fuel adaptive value < -30%
P2179	System Too Lean Off Idle Bank 2	Fuel adaptive value > 30%

<b>DTC</b>	<b>Error Message</b>	<b>Malfunction Criteria and Threshold Value</b>
P2180	System Too Rich Off Idle Bank 2	Fuel adaptive value < -30%
P2181	Cooling System Performance	Cooling system temperature too low after a sufficient mass air flow integral 60 - 70 °C
P2187	System Too Lean at Idle, Bank 1	Fuel adaptive value > 6%
P2188	System Too Rich at Idle, Bank 1	Fuel adaptive value < -6%
P2189	System Too Lean at Idle, Bank 2	Fuel adaptive value > 6%
P2190	System Too Rich at Idle, Bank 2	Fuel adaptive value < -6%
P2195	O2 Sensor Signal Biased/ Stuck Lean (Bank 1, Sensor 1)	Delta lambda of 2nd lambda control loop > 0.059
P2196	O2 Sensor Signal Biased/ Stuck Rich (Bank 1, Sensor 1)	Delta lambda of 2nd lambda control loop < -0.059
P2197	O2 Sensor Signal Stuck Lean (Bank 2 Sensor 1)	Delta lambda of 2nd lambda control loop > 0.059
P2198	O2 Sensor Signal Stuck Rich (Bank 2 Sensor 1)	Delta lambda of 2nd lambda control loop < -0.059
P2231	O2 Sensor (Bank 1 Sensor 1) Signal Circuit Shorted to Heater Circuit	Delta O2S signal front > 190 uA
P2237	O2 Sensor Positive Current Control Circuit/Open (Bank 1, Sensor 1)	<ul style="list-style-type: none"> <li>• O2S signal front &lt; 1.70 V</li> <li>• Fuel cutoff &gt; 3 sec.</li> </ul> or <ul style="list-style-type: none"> <li>• O2S signal front 1.49 - 1.51 V</li> <li>• Delta lambda controller &gt; 0.07</li> </ul>
P2240	O2 Sensor Positive Current Control Circuit (Bank 2 Sensor 1) Open	<ul style="list-style-type: none"> <li>• O2S signal front &lt; 1.70 V</li> <li>• Fuel cutoff &gt; 3 sec.</li> </ul> or <ul style="list-style-type: none"> <li>• O2S signal front 1.49 - 1.51 V</li> <li>• Delta lambda controller &gt; 0.07</li> </ul>
P2243	O2 Sensor Reference Voltage Circuit/Open (Bank 1, Sensor 1)	<ul style="list-style-type: none"> <li>• O2S signal front &gt; 4.80 V and Internal resistance &gt; 950 Ohms</li> <li>• O2S signal front &lt; 0.25 V and Internal resistance &gt; 950 Ohms</li> </ul>

DTC	Error Message	Malfunction Criteria and Threshold Value
P2247	O2 Sensor Reference Voltage Circuit (Bank 2 Sensor 1) Open	<ul style="list-style-type: none"> <li>• O2S signal front &gt; 4.80 V and Internal resistance &gt; 950 Ohms</li> <li>• O2S signal front &lt; 0.25 V and Internal resistance &gt; 950 Ohms</li> </ul>
P2251	O2 Sensor Negative Current Control Circuit (Bank 1 Sensor 1) Open	<ul style="list-style-type: none"> <li>• O2S signal front 1.47 - 1.52 V and</li> <li>• Internal resistance &gt; 950 ohms</li> </ul>
P2254	O2 Sensor Negative Current Control Circuit (Bank 2 Sensor 1) Open	<ul style="list-style-type: none"> <li>• O2S signal front 1.47 - 1.52 V and</li> <li>• Internal resistance &gt; 950 ohms</li> </ul>
P2270	O2 Sensor Signal Stuck Lean (Bank 1 Sensor 2)	O2S signal rear not oscillating at reference < 0.65 V
P2271	O2 Sensor Signal Stuck Rich (Bank 1, Sensor 2)	<ul style="list-style-type: none"> <li>• O2S signal rear not oscillating at reference &gt; 0.65 V</li> <li>or</li> <li>• Response time at fuel cutoff &gt; 5 Sec.</li> <li>• Measurement range from fuel cutoff to voltage threshold ≤ 118 mV</li> <li>• Number of checks ≥ 1</li> </ul>
P2272	O2 Sensor Signal Stuck Lean (Bank 2 Sensor 2)	O2S signal rear not oscillating at reference < 0.65 V
P2273	O2 Sensor Signal Stuck Rich (Bank 2 Sensor 2)	<ul style="list-style-type: none"> <li>• O2S signal rear not oscillating at reference &gt; 0.65 V</li> <li>or</li> <li>• Response time at fuel cutoff &gt; 5 Sec.</li> <li>• Measurement range from fuel cutoff to voltage threshold ≤ 118 mV</li> <li>• Number of checks ≥ 1</li> </ul>
P2279	Intake Air System Leak	<ul style="list-style-type: none"> <li>• Threshold to detect a defective system &gt; 2.50</li> <li>and</li> <li>• Ratio of the tie system defective during the measurement window to the whole duration of the measurement window &gt; 0.80</li> </ul>

<b>DTC</b>	<b>Error Message</b>	<b>Malfunction Criteria and Threshold Value</b>
P2293	Fuel Pressure Regulator 2 Performance	<ul style="list-style-type: none"> <li>• Difference between target pressure vs. actual pressure: &gt; 1.50 mPa</li> <li>or</li> <li>• &lt; -1.50 mPa</li> </ul>
P2294	Fuel Pressure Regulator 2 Control Circuit	<ul style="list-style-type: none"> <li>• Signal voltage 1.40 - 3.20 V (Open Circuit)</li> <li>• Signal pattern incorrect (Rationality Check)</li> </ul>
P2295	Fuel Pressure Regulator 2 Control Circuit Low Short to Ground	Signal voltage < 1.40 - 3.20 V
P2296	Fuel Pressure Regulator 2 Control Circuit High	Signal voltage > 3.20 V

### **Ignition System**

<b>DTC</b>	<b>Error Message</b>	<b>Malfunction Criteria and Threshold Value</b>
P2300	Ignition Coil A Primary Control Circuit Low	Signal current > 24.0 mA
P2301	Ignition Coil A Primary Control Circuit High	Signal voltage > 5.1 to 7.0 V
P2303	Ignition Coil B Primary Control Circuit Low	Signal current > 24.0 mA
P2304	Ignition Coil B Primary Control Circuit High	Signal voltage > 5.1 to 7.0 V
P2306	Ignition Coil C Primary Control Circuit Low	Signal current > 24.0 mA
P2307	Ignition Coil C Primary Control Circuit High	Signal voltage > 5.1 to 7.0 V
P2309	Ignition Coil D Primary Control Circuit Low	Signal current > 24.0 mA
P2310	Ignition Coil D Primary Control Circuit High	Signal voltage > 5.1 to 7.0 V
P2312	Ignition Coil E Primary Control Circuit Low	Signal current > 24.0 mA
P2313	Ignition Coil E Primary Control Circuit High	Signal voltage > 5.1 to 7.0 V
P2315	Ignition Coil F Primary Control Circuit Low	Signal current > 24.0 mA

DTC	Error Message	Malfunction Criteria and Threshold Value
P2316	Ignition Coil F Primary Control Circuit High	Signal voltage > 5.1 to 7.0 V

### Additional Emissions Regulations

DTC	Error Message	Malfunction Criteria and Threshold Value
P2400	Evaporative Emission System Leak Detection Pump Control Circuit/Open	Signal voltage > 4.4 - 5.6 V
P2401	Evaporative Emission System Leak Detection Pump Control Circuit Low	Signal voltage < 2.15 to 3.25 V
P2402	Evaporative Emission System Leak Detection Pump Control Circuit High	Signal current > 3.0 A
P2403	Evaporative Emission System Leak Detection Pump Sense Circuit/Open	Low signal voltage > 0.5 Sec.
P2404	Evaporative Emission System Leak Detection Pump Sense Circuit Range/Performance	<ul style="list-style-type: none"> <li>• High signal voltage &gt; 12 Sec.</li> <li>• Number of checks = 30</li> <li>• Cumulative time of high signal voltage during pumping &gt; 20 Sec.</li> </ul>
P2414	O2 Sensor Exhaust Sample Error (Bank 1, Sensor 1)	<ul style="list-style-type: none"> <li>• Threshold 1 - Signal voltage 3.70 - 4.81 V</li> <li>• Threshold 2 - Signal voltage 3.0 to 3.70 V</li> </ul>
P2415	O2 Sensor Exhaust Sample Error (Bank 2 Sensor 1)	<ul style="list-style-type: none"> <li>• Threshold 1 - Signal voltage 3.70 - 4.81 V</li> <li>• Threshold 2 - Signal voltage 3.0 to 3.70 V</li> </ul>
P2539	Low Pressure Fuel System Sensor Circuit	Signal voltage > 4.80 V
P2541	Low Pressure Fuel System Sensor Circuit Low Input	Signal voltage < 0.2 V
P2600	Coolant Pump Control Circuit Open	Signal voltage 4.8 to 5.3 V
P2602	Coolant Pump Control Circuit Low	Signal voltage < 2.8 to 3.2 V
P2603	Coolant Pump Control Circuit High	Signal current > 5.5 to 10.0 A

<b>DTC</b>	<b>Error Message</b>	<b>Malfunction Criteria and Threshold Value</b>
P261A	Coolant Pump "B" Control Circuit/Open	Signal voltage 4.8 to 5.3 V
P261C	Coolant Pump "B" Control Circuit Low	Signal voltage < 2.8 to 3.2 V
P261D	Coolant Pump "B" Control Circuit High	Signal current > 2.2 to 4.4 A
P2626	O2 Sensor Pumping Current Trim Circuit/Open (Bank 1 Sensor 1)	O2S signal front > 4.81 V
P2629	O2 Sensor Pumping Current Trim Circuit/Open (Bank 2, Sensor 1)	O2S signal front > 4.81 V



**Volkswagen Group of America works constantly to develop and improve its products. We must therefore reserve the right to change or update any part of this technical manual at any time. No legal commitment can therefore be derived from the information, illustrations or descriptions in this manual.**

**The texts, illustrations and standards in this manual are based on the information available at the time of printing. No part of this manual may be reprinted, reproduced or translated without the written permission of Volkswagen Group of America.**

**All rights under the copyright laws are expressly reserved by Volkswagen Group of America. Subject to alteration and amendment.**

**Printed in the United States of America  
© 2012 Volkswagen Group of America, Inc.**

