

(3)

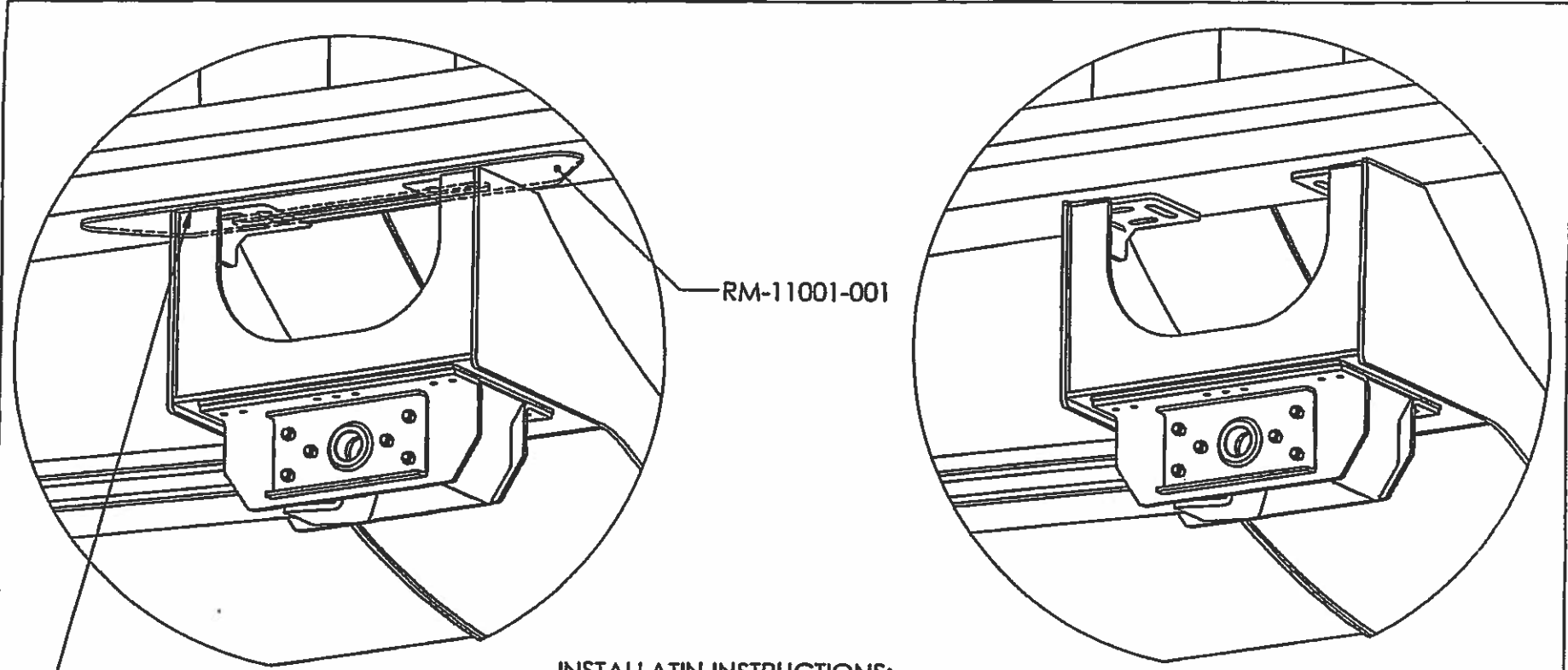

RM-11001-001

TRIM CENTER BOLSTER AT THE SIDE RAIL TO ALLOW 1/4" WELD PAD TO BE INSTALLED AND WELDED

INSTALLATION INSTRUCTIONS:

- 1) REMOVE PIVOT BRACKET COVER
- 2) USING A PLASMA TORCH OR SUITABLE MEANS, CUT BACK 1/4" OF THE TOP OF THE BOLSTER AWAY FROM THE SIDE RAIL.
- 3) STOP DRILL CRACKS THAT PROCEED INTO THE BOTTOM RAIL. VEE-OUT AND WELD AND GRIND SMOOTH
- 4) POSITION WELD PAD AND WELD SOLID WHERE POSSIBLE. BE SURE TO WELD BACK SIDE OF SLOT AS WELL.
- 5) WELD BOLSTER TO THE "WELD PAD".
- 6) RE-INSTALL PIVOT BRACKET COVER

REV.	DESCRIPTION	ECN	DWN	DATE	CKD
REVISIONS					
<small>FORCE IS HEREBY GIVEN THAT THIS DRAWING INCLUDES A CONFIDENTIAL PROPRIETARY DESIGN OR PART OF A CONFIDENTIAL PROPRIETARY DESIGN OR INVENTION OF THE CUSTOMER, AND ALL DESIGN, MANUFACTURING, REPRODUCTION, USE AND SALE RIGHTS INCLUDING THE SAME ARE EXPRESSLY RESERVED. IT IS SUBMITTED UNDER A CONFIDENTIAL RELATIONSHIP FOR A SPECIFIC PURPOSE, AND THE RECIPIER BY ACCEPTING THIS DRAWING AGREES NOT TO DISCLOSE ANY INFORMATION REGARDING IT TO ANY UNAUTHORIZED PERSON, OR TO INCORPORATE IN OTHER PROJECTS, ANY SPECIAL FEATURES PROVIDED IN THIS DESIGN.</small>					
DO NOT SCALE DRAWING TOLERANCES UNLESS NOTED: FRACTIONS ±1/16 ANGLES ±1° DECIMALS ±0.010		MODIFICATION, CENTER BOLSTER HYBRID FRAMELESS			
MATERIAL ASSEMBLY		OWN BY: CLB DATE: 5/4/2011 CKD BY: JMP		SCALE: 3:32 WGT: 3712.49 LBS SHEET: 1 OF 1	
				RM-11001-000	



EAST MANUFACTURING CORP.
 RANDOLPH, OHIO 44265

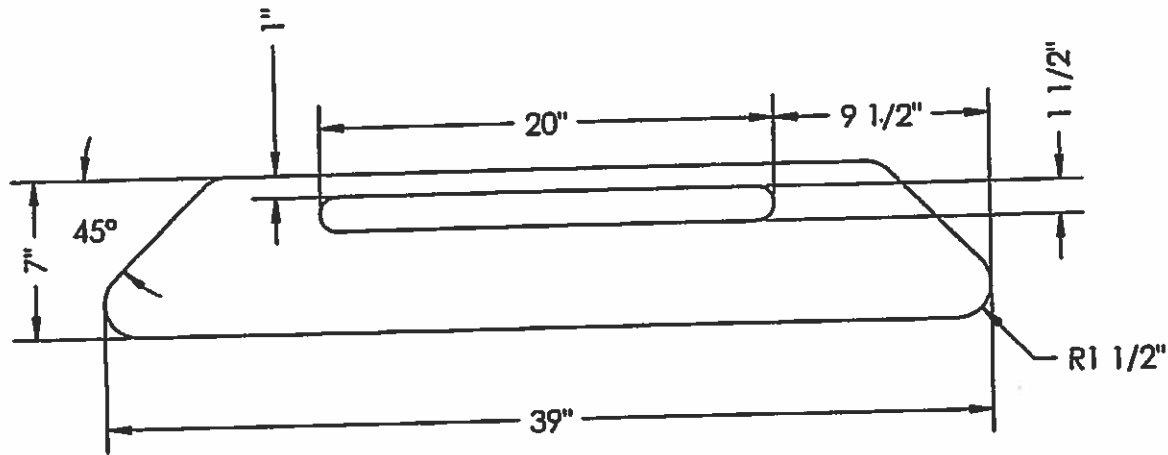
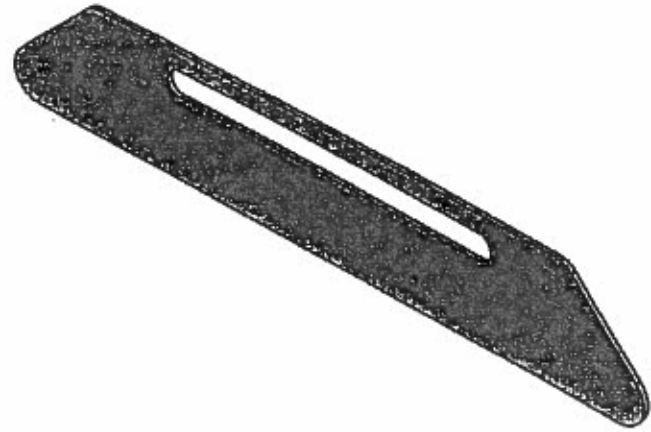

REV.	DESCRIPTION	ECN	OWN	DATE	CKD
------	-------------	-----	-----	------	-----

REVISIONS

NOTICE IS HEREBY GIVEN THAT THIS DRAWING INCLUDES A CONFIDENTIAL TECHNOLOGY DESIGN OR IS PART OF A CONFIDENTIAL PROPRIETARY DESIGN DEVELOPED BY ORSIVES OR ONE OF OUR CUSTOMERS, AND ALL DESIGN, MANUFACTURING, REPRODUCTION, USE AND SALE RIGHTS REGARDING THE SAME ARE EXPRESSLY RESERVED. IT IS GRANTED UNDER A CONFIDENTIAL RELATIONSHIP FOR A SPECIFIC PURPOSE, AND THE RECEIVER BY ACCEPTING THE DRAWING AGREES NOT TO DISSEMINATE ANY INFORMATION REGARDING IT TO ANY UNAUTHORIZED PERSON, OR TO INCORPORATE IN OTHER PRODUCTS, ANY SPECIAL TREATING TECHNIQUE TO THIS DESIGN.

DO NOT SCALE DRAWING

TOLERANCES
UNLESS
NOTED:

FRACTIONS	±1/16
ANGLES	±1°
DECIMALS	±0.010

TITLE
PAD, WELD

MATERIAL
1/4 SM ALUMINUM X 7" X 39"



EAST MANUFACTURING CORP.
RANDOLPH, OHIO 44265

DWN BY CLB	SCALE 1:8	REV A	SUPPLIER
DATE 5/4/2011	WGT. 5.33 LBS	RM-11001-001	
CKD BY	DR. 1 OF 1		

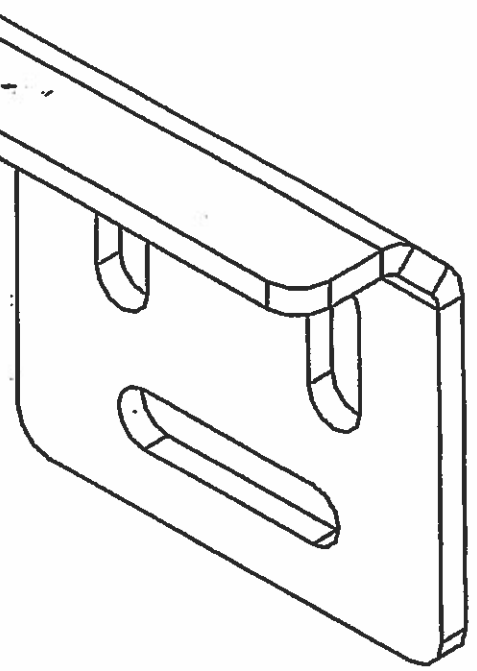
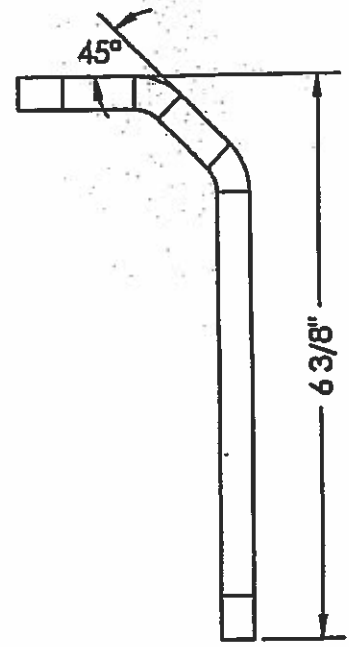
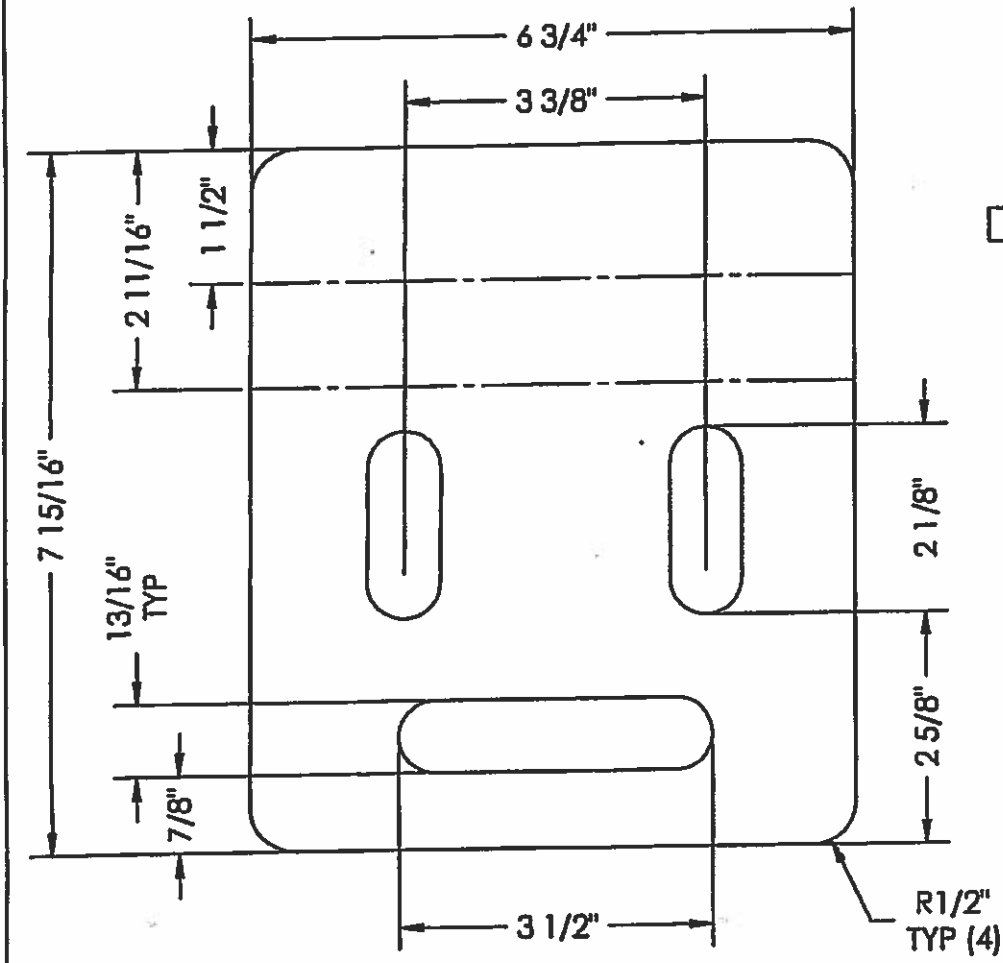

REV.	DESCRIPTION	ECN	DWN	DATE	CKD
REVISIONS					

NOTICE IS HEREBY GIVEN THAT THIS DRAWING SHOWS A CONFIDENTIAL PROPRIETARY DESIGN OR PART OF A CONFIDENTIAL PROPRIETARY DESIGN OR TRADE SECRET OF EAST MANUFACTURING CORP. AND ALL DESIGN, MANUFACTURING, REPRODUCTION, USE AND SALE HEREIN REGARDING THE SAME ARE EXPRESSLY RESERVED. IT IS GRANTED UNDER A CONFIDENTIAL RELATIONSHIP FOR A SPECIFIC PURPOSE, AND THE RECEIPT BY ACCEPTING THIS DRAWING AGREES NOT TO REPRODUCE OR DISCLOSE ANY INFORMATION RELAYING IT TO ANY UNAUTHORIZED PERSON OR TO REPRODUCE IN OTHER PRODUCTS, AND SPECIAL AGREEMENTS APPLY TO ALL DESIGN.

DO NOT SCALE DRAWING

TOLERANCES
UNLESS NOTED:

FRACTIONS	±.014
ANGLES	±.1°
DECIMALS	±.0010

REINFORCEMENT, PIVOT BRACKET
HYBRID FRAMELESS

MATERIAL
3/8 SM ALUMINUM X 6 3/4" X 7 15/16"



EAST MANUFACTURING CORP.
RANDOLPH, OHIO 44265

DWN BY CLB	SCALE 1:2	SHE A	SUPERSEDES
DATE 8/5/2011	WGHT 1.74 LBS	016-10072-00	
CKD BY	SG, 1 OF 1		

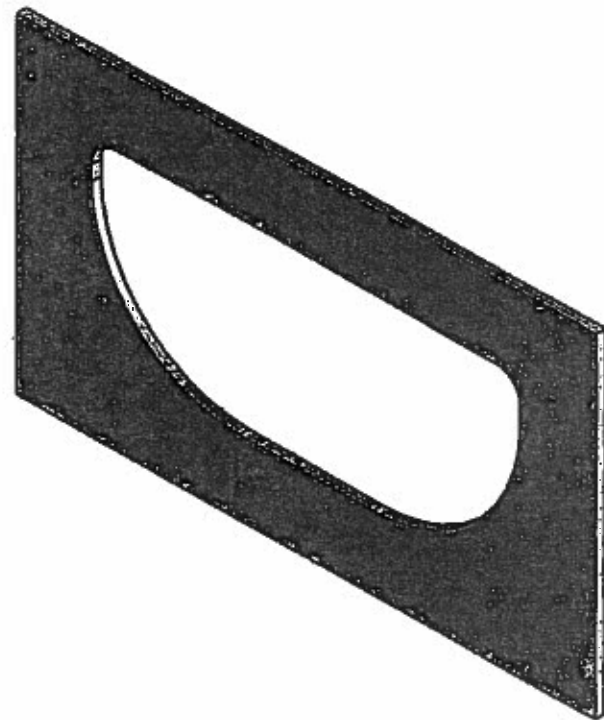
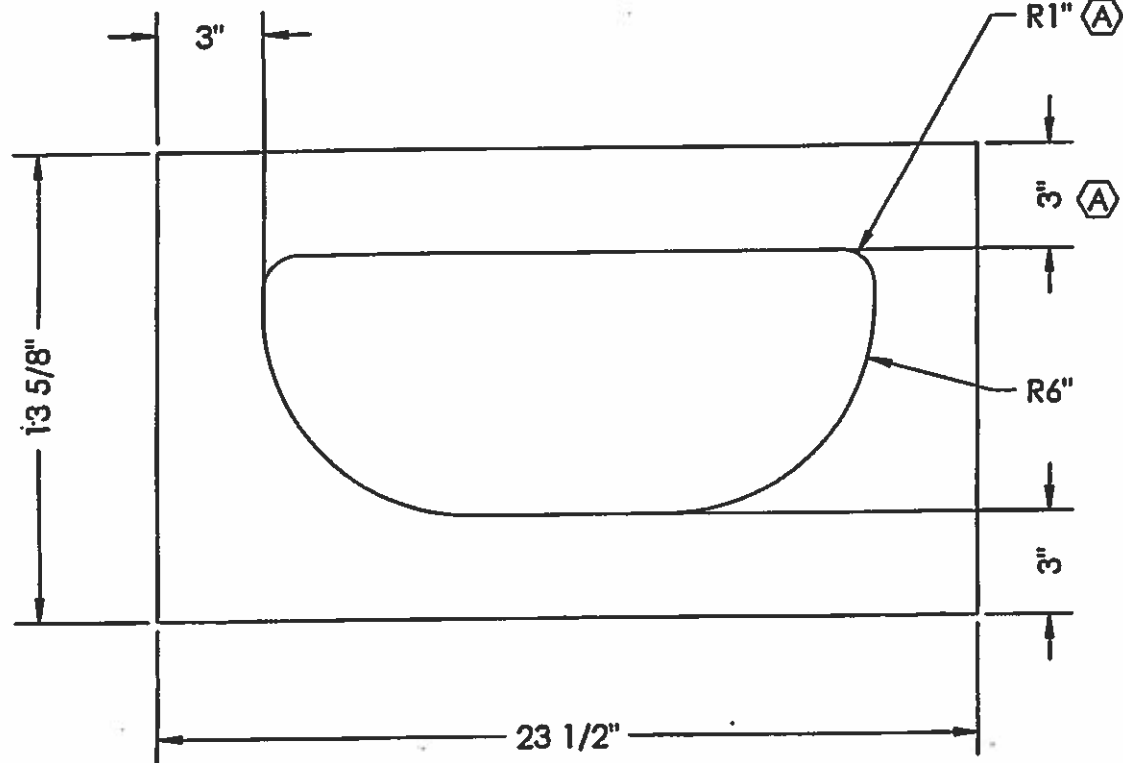

A	Added material and radii		D.D.	12/13/2010	
REV.	DESCRIPTION	ECN	DWN	DATE	CKD

REVISIONS

NOTICE & RESTRICTION: THIS DRAWING SHOWS A CONFIDENTIAL PROPRIETARY DESIGN OR IS PART OF A CONFIDENTIAL PROPRIETARY DESIGN DISCLOSED BY CURVES OR ONE OF OUR DESIGNERS, AND ALL DESIGN, MANUFACTURING, REPRODUCTION, USE AND SALE RIGHTS REGARDING THE SAME ARE EXPRESSLY RESERVED. IT IS SUBMITTED UNDER A CONFIDENTIAL RELATIONSHIP FOR A SPECIFIC PURPOSE, AND THE RECIPIER, BY ACCEPTING THIS DRAWING, AGREES NOT TO REPLY OR DISCLOSE ANY INFORMATION REGARDING IT TO ANY UNAUTHORIZED PERSON OR TO INCORPORATE IN OTHER PRODUCTS, ANY SPECIAL FEATURES PARTICULAR TO THIS DESIGN.

DO NOT SCALE DRAWING

TOLERANCES

UNLESS NOTED:

FRACTIONS	±1/16
ANGLES	±1°
DECIMALS	±0.010

TITLE
**GUSSET, REAR BOLSTER SUPPORT
 GENESIS HYBRID**

MATERIAL
3/8 SM ALUMINUM X 13 5/8" X 23 1/2"



EAST MANUFACTURING CORP.
 RANDOLPH, OHIO 44265

DWN BY	CLB	SCALE	3:16	SIZE	A	SUPP/REQD	
DATE	8/31/2010	WGT.	7.41 LBS	016-10030-00			
CKD BY	CLB	SR.	1 OF 1				