

Porsche Rear Seat Entertainment (PRSE III) Display Unit Replacement



Information

This bulletin replaces bulletin Group 9, #42/10, dated February 15, 2011.

Information: **Replacing display unit**

Model Year: **As of 2010 up to 2015**

Note: The software in the new display unit is either V02.000 or V02.009. The previous software version was V01.xxx. A USB stick is enclosed with the new display unit. Use the USB stick to update V01.xxx of the software of the other display unit to version V02.000. It is not possible to update software versions V01.xxx and V02.000 to software version V02.009.

Parts Info: **970.645.991.00 FFF¹** ⇒ Display unit

¹ The color code can be found in the Porsche Electronic Parts Catalog (PET).

Assembly: 1 Connect a battery charger. ⇒ *Workshop Manual '2X00IN Battery trickle charging'*

2 Remove display unit.

2.1 Loosen guide pins at the left and right.

2.1.1 Insert a suitable tool (e.g. a small screwdriver or a drift punch with a 2-mm diameter) into the display unit ⇒ *Figure 1 -1-*.

2.1.2 Press the tool outwards ⇒ *Figure 1 -arrow A-* and at the same time, carefully move the display unit back and forward in direction of arrow ⇒ *Figure 1 -arrow B-* until the locking lugs at the left and right are released.

2.2 Carefully pull the display unit out of the guides and disconnect the plug connections.

3 Install display unit.

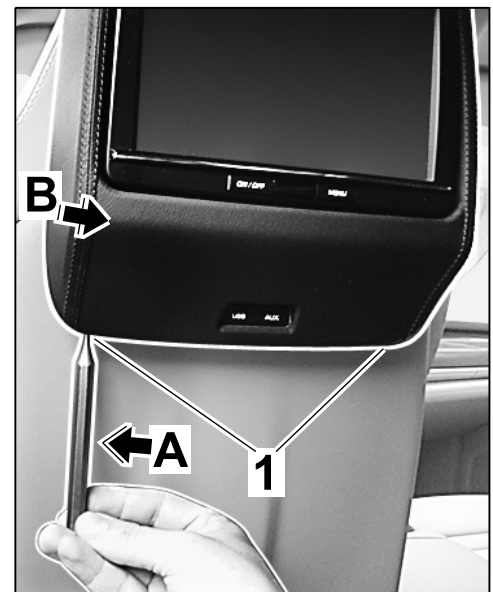

Figure 1

- 3.1 Place electric lines ⇒ *Figure 2-2-* from the display unit in front of the guide pin ⇒ *Figure 3-1-*.

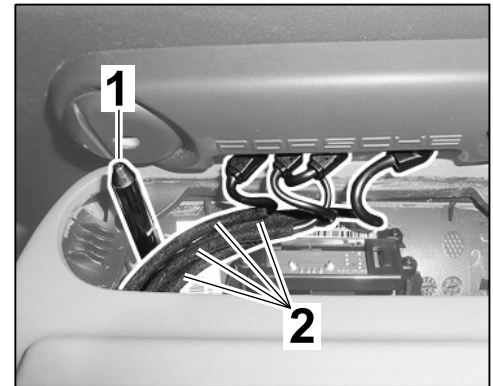

Figure 2

- 3.2 Establish plug connection (4x) with rear of driver seat/passenger seat ⇒ *Figure 3-arrow-*.

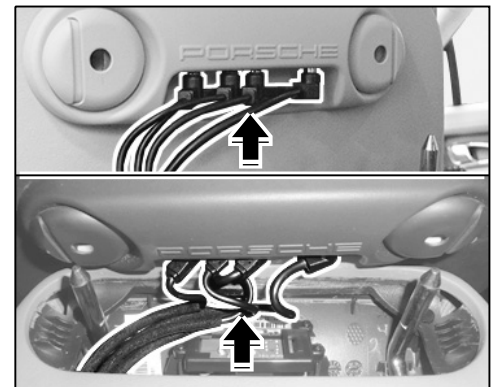

Figure 3

NOTICE

Incorrect installation or operation of the display.

- Risk of damage to the display
- ⇒ Do not exert pressure on the display.
- ⇒ Only push/press the display unit at the plastic console.

- 3.3 Insert the guide pins ⇒ *Figure 4-1*- as far as they will go into the mountings ⇒ *Figure 4* -**arrows**- until the locking lugs on both sides lock with an audible click.



Figure 4

- 3.4 Check that you can swivel the screen. Place your thumbs on the outer part of the chrome strip ⇒ *Figure 5* -**arrow A**- and press the screen inwards. Then swivel the screen back by pressing ⇒ *Figure 5* -**arrow B**-. Loosen the display unit if necessary and check the line routing. See Step 2 (Remove display unit).

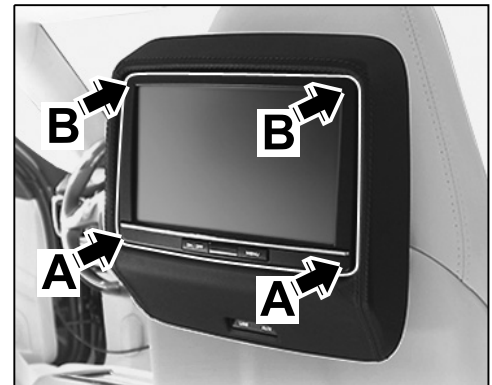

Figure 5



Information

The software in the new display unit is either V02.000 or V02.009. The previous software version was V01.xxx. A USB stick is enclosed with the new display unit. The USB stick is used to update V01.xxx of the software of the other display unit to version V02.000.

It is not possible to update software versions V01.xxx and V02.000 to software version V02.009.

- 4 Check the software version of both display units.
 - 4.1 Switch on the display units. To do this, press the **ON/OFF** button on both display units for about 2 seconds. PRSE is ready for operation after about 5 seconds.
 - 4.2 Press the **Option** button on both display units.
 - 4.3 Press the **System info** button on both display units.
 - 4.4 Is software version **V02.000** or **V02.009** displayed?

Yes: Continue with Step 6.

No: Continue with Step 5.



Information

Previously saved display unit settings are not changed!

- 5 Update software version V01.xxx of the display unit to software version V02.000.
 - 5.1 Switch off the display units. To do this, press and hold the **ON/OFF** button for about 2 seconds.
 - 5.2 Insert the USB stick in the USB port of the display unit running software version V01.xxx.
 - 5.3 Switch on the display unit. To do this, press the **ON/OFF** button for about 2 seconds. PRSE is ready for operation after about 5 seconds.
 - 5.4 The software update is automatically started. The display unit switches off after the software update is complete.
 - 5.5 Remove the USB stick from the USB jack on the display unit.
- 6 Adjust the basic setting of the new display unit.
 - 6.1 Switch on the display unit. To do this, press the **ON/OFF** button for about 2 seconds. PRSE is ready for operation after about 5 seconds.
 - 6.2 Press the **OPTION** button.



Figure 6

6.3 Press the **SET PRSE system** button.

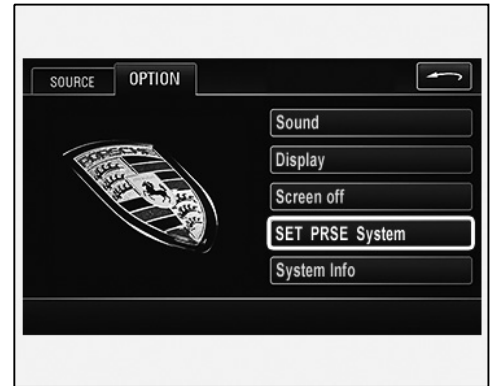

Figure 7

6.4 Select the **Language** button.

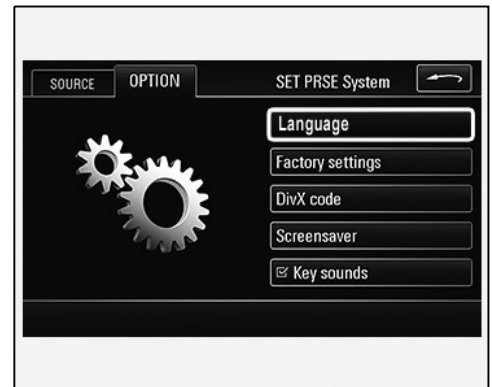

Figure 8

Select the required language for your country and then press **Back** ⇒ *Figure 9-1-*.

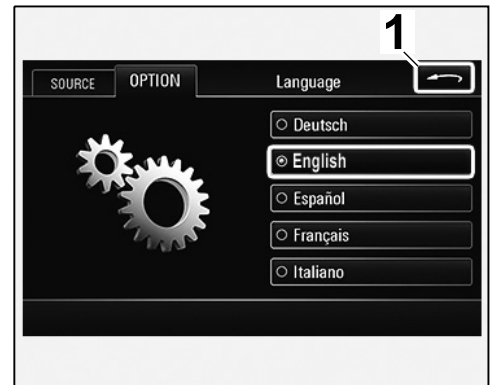

Figure 9

6.5 Select the **Factory settings** button.

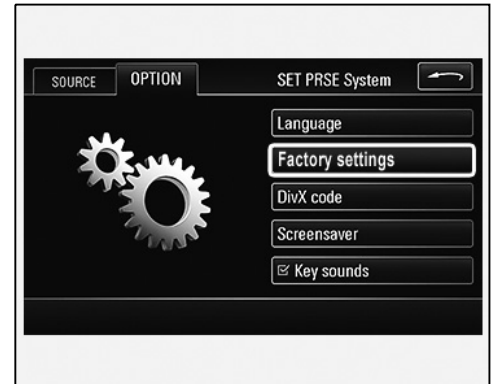

Figure 10

6.6 Select the **Service** button.

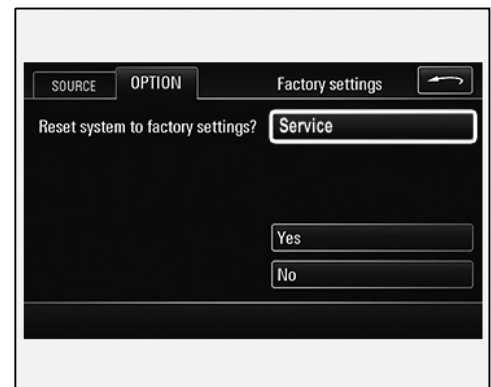

Figure 11

6.7 Enter the code **2 4 7 0 6**.

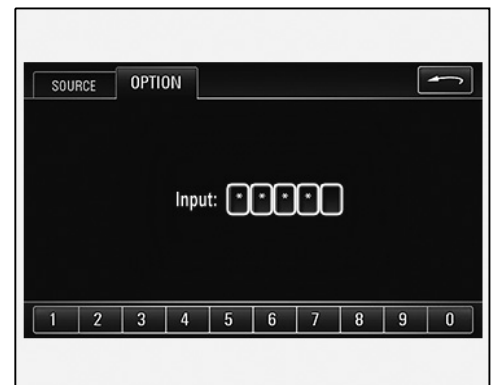

Figure 12

6.8 Select the **IR channel setting** button.



Figure 13

Passenger's side:
Select **Channel A**.

Driver's side:
Select **channel B**.
Then press **Back** ⇒ Figure 14 -1-.

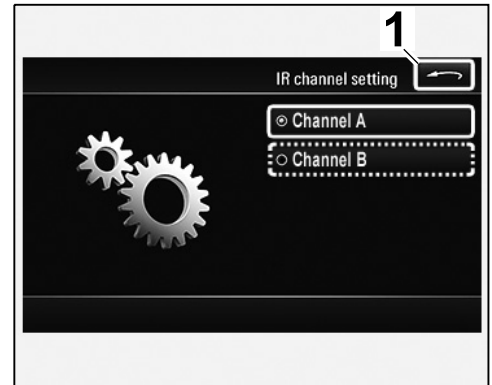

Figure 14

6.9 Select **Region code**.

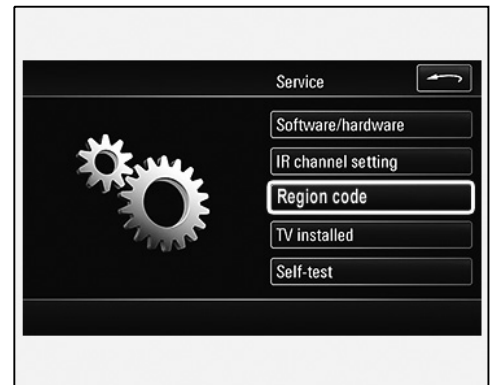

Figure 15

Select a code in accordance with the table below and then press **Back** ⇒ *Figure 16-1*.

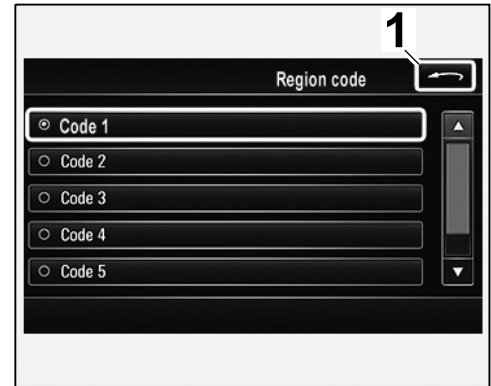

Figure 16

Code 1	USA, Canada and US external territories.
Code 2	Western and Central Europe, Greenland, South Africa, Egypt and Middle East, Japan.
Code 3	South-East Asia, South Korea, Hong Kong, Indonesia, Philippines, Taiwan.
Code 4	Australia, New Zealand, Mexico, Central America, South America.
Code 5	Eastern Europe and other countries of the former USSR, India, Africa.
Code 6	People's Republic of China

6.10 **Only** for vehicles with TV tuner:
Select **TV installed**.



Figure 17

Select the **installed** button and check that the **TV sound** button is activated (box ticked) ⇒ *Figure 18-2-*. Activate it by pressing the **TV sound** button if necessary. Then press **Back** ⇒ *Figure 18-1-*.

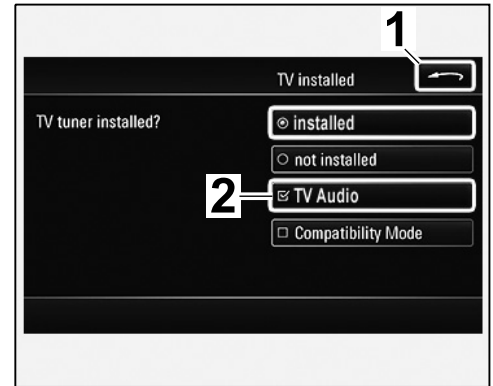

Figure 18

6.11 Set the required channel (A/B) ⇒ *Figure 19-1-* for the headphones in accordance with the IR channel setting on the display unit.
Passenger's side:
Select **Channel A**.

Driver's side:
Select **Channel B**.



Information

The headphones will switch off automatically after about 20 seconds if no audio signal is received or if the headphones are outside of the reception range.

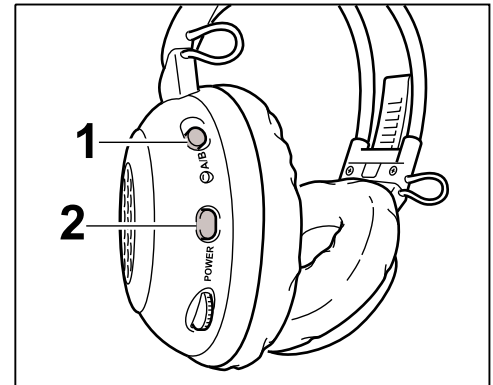

Figure 19

Switch on headphones ⇒ *Figure 19-2-* and put them on.

6.12 Select the **Self-test** button.



Figure 20

Select the **Yes** button.

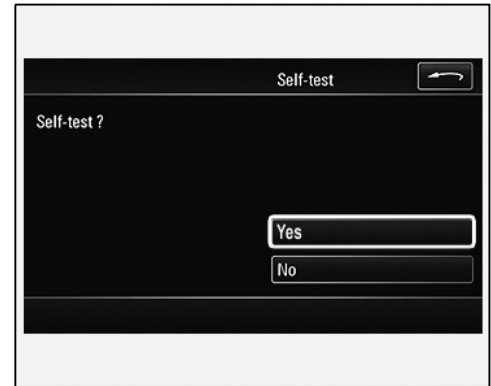

Figure 21

6.13 When the self-test has finished, press **Back**.



Figure 22

6.14 Select **Yes** in response to the query **Save changes?**.

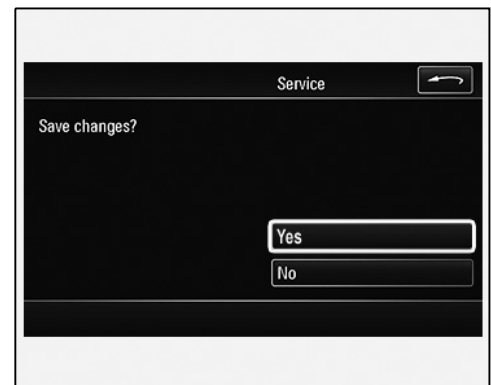

Figure 23

Once the change has been stored and depending on vehicle equipment, the following screen appears ⇒ *Figure 24*.

- 7 Perform a function test.
 - 7.1 Test the display unit.

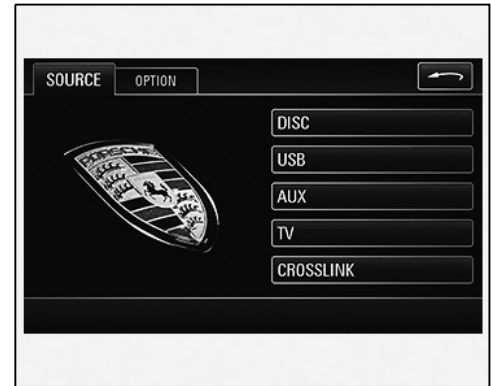

Figure 24

NOTICE

Incorrect installation or operation of the display.

- Risk of damage to the display
- ⇒ Do not exert pressure on the display.
- ⇒ Only push/press the display unit at the plastic console.

- 7.1.1 Press the display unit inwards by pressing on the outer area of the chrome strip with both thumbs ⇒ *Figure 25 -A-* until the slot is accessible.

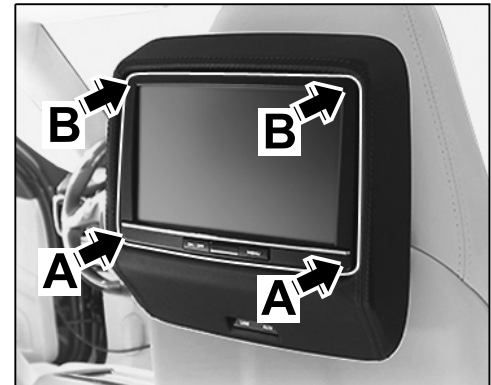

Figure 25

- 7.1.2 Insert a CD/DVD ⇒ *Figure 26-9-* so that the printed side is facing you. Once the DVD/CD is inserted fully, swivel the display unit ⇒ *Figure 25-B-* back. The CD/DVD starts playing. Press the Menu button on the console if necessary and select **SOURCE**, then **DISK**.

Check the sound and picture and change the channel setting on the headphones if necessary.

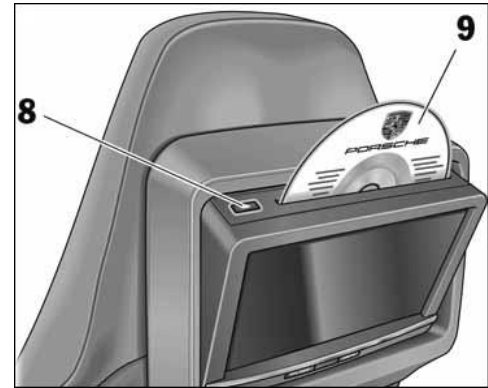

Figure 26

- 7.1.3 Check transmission/reception function **CROSSLINK**. Select **CROSSLINK** in the **SOURCE** menu on the second display unit. Check the sound and picture and change the channel setting on the headphones if necessary.
- 7.1.4 **Only** for vehicles with TV tuner: Check TV signal on the display unit. Press the Menu button on the console. Select **TV** in the **SOURCE** menu. Check the sound and picture and change the channel setting on the headphones if necessary.

NOTICE

Incorrect installation or operation of the display.

- **Risk of damage to the display**
- ⇒ **Do not exert pressure on the display.**
- ⇒ **Only push/press the display unit at the plastic console.**

- 7.1.5 Press the display unit inwards by pressing on the outer part of the chrome strip with both thumbs ⇒ *Figure 25-A-* until the slot is accessible. Press the eject button ⇒ *Figure 26-8-*, remove the DVD/CD and swivel back the display unit ⇒ *Figure 25-B-*.
- 7.2 Check transmission/reception function **CROSSLINK** on a display unit that has **not** been changed (replaced); to do this perform Steps 7.1.1 to 7.1.3.
- 7.3 Switch off the display units. To do this, press and hold the **ON/OFF** button for about 2 seconds.
- 7.4 Take off the headphones and switch them off.

7.5 Fold the outer ear cups into each other and stow the headphones away.

8 Disconnect battery charger. ⇒ *Workshop Manual '2X00IN Battery trickle charging'*

Working Time: 91945540: Replace display unit

Labor time: **60 TU**

Important Notice: Technical Bulletins issued by Porsche Cars North America, Inc. are intended only for use by professional automotive technicians who have attended Porsche service training courses. They are written to inform those technicians of conditions that may occur on some Porsche vehicles, or to provide information that could assist in the proper servicing of a vehicle. Porsche special tools may be necessary in order to perform certain operations identified in these bulletins. Use of tools and procedures other than those Porsche recommends in these bulletins may be detrimental to the safe operation of your vehicle, and may endanger the people working on it. Properly trained Porsche technicians have the equipment, tools, safety instructions, and know-how to do the job properly and safely. If a particular condition is described, do not assume that the bulletin applies to your vehicle, or that your vehicle will have that condition. See your authorized Porsche Dealer for the latest information about whether a particular technical bulletin applies to your vehicle. Part numbers listed in these bulletins are for reference only. Always check with your authorized Porsche dealer to verify the current and correct part numbers. The work procedures updated electronically in the Porsche PIWIS diagnostic and testing device take precedence and, in the event of a discrepancy, the work procedures in the PIWIS Tester are the ones that must be followed.

© Porsche Cars North America, Inc.

Dealership	Service Manager	Shop Foreman	Service Technician
Distribution			
Routing	Asst. Manager	Warranty Admin.	Service Technician

Dr. Ing. h.c. F. Porsche AG is the owner of numerous trademarks, both registered and unregistered, including without limitation the Porsche Crest®, Porsche®, Boxster®, Carrera®, Cayenne®, Cayman®, Macan®, Panamera®, Speedster®, Spyder®, 918 Spyder®, Tiptronic®, VarioCam®, PCM®, PDK®, 911®, RS®, 4S®, FOUR, UNCOMPROMISED®, and the model numbers and the distinctive shapes of the Porsche automobiles such as, the federally registered 911 and Boxster automobiles. The third party trademarks contained herein are the properties of their respective owners. Porsche Cars North America, Inc. believes the specifications to be correct at the time of printing. Specifications, performance standards, standard equipment, options, and other elements shown are subject to change without notice. Some options may be unavailable when a car is built. Some vehicles may be shown with non-U.S. equipment. The information contained herein is for internal authorized Porsche dealer use only and cannot be copied or distributed. Porsche recommends seat belt usage and observance of traffic laws at all times.

Printed in the USA