

# SERVICE INFORMATION BULLETIN

**Subject:**  
**DESIGN CHANGE TO EXHAUST GAS RECIRCULATION (EGR) VALVE AND GASKET ON J05D-TF ENGINES**

This document is to inform dealers and workshops of the design change to the exhaust gas recirculation (EGR) valve and gasket for the J05D-TF engine series.

**1. RELEVANT MODELS**

2008 and 2009 J05D TF North American engines.  
NA6J (145), NB6J (165), NC6J (185).

**2. DESIGN CHANGE**

- A) Change in internal diameter of hole in mounting gasket.
- B) Change in diameter of the return spring stopper pin.

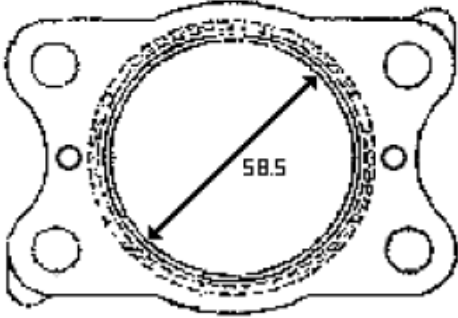
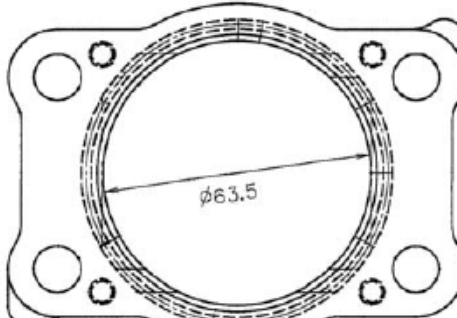
	CURRENT PART NO.	NEW PART NO
<b>Gasket part #</b>	<b>25627E0040</b>	<b>25627E0060</b>
<b>Hole Diameter</b>	<b>Diameter 58.5mm.</b>	<b>Diameter 63.5mm.</b>
<b>View of gasket</b>		

# SERVICE INFORMATION BULLETIN

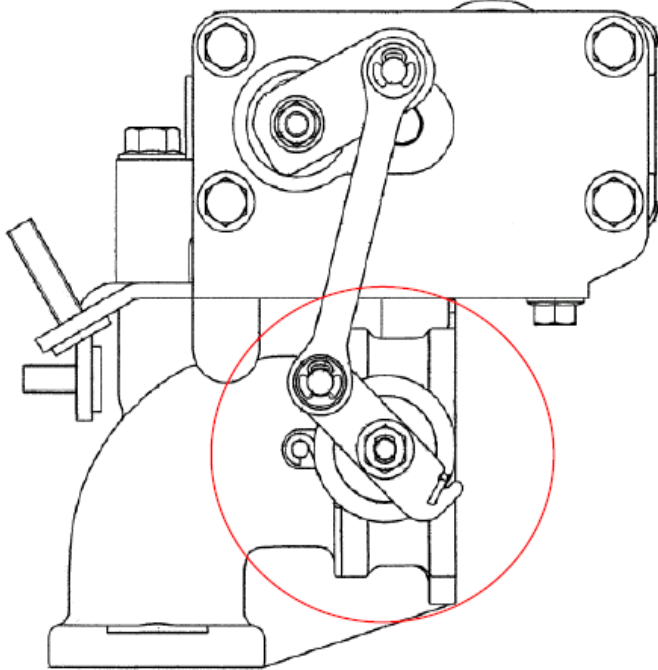
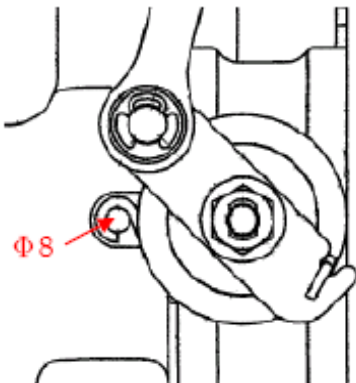
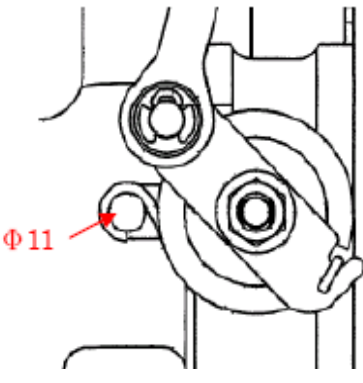
	CURRENT PART	NEW PART
<b>EGR Part #</b>	<b>25620E0091</b>	<b>25620E0230</b>
<b>Diameter of Pin</b>	<b>8 mm</b>	<b>11 mm</b>
<b>View of EGR</b>		
<b>View of return spring stopper pin</b>		

### 3. EFFECTIVE DATE

Production from July, 2008 onward.

### 4. INTERCHANGEABILITY

The new part is interchangeable with the current part as a set.  
Use the current gasket, if using the current EGR.