

# SERVICE INFORMATION BULLETIN

**Subject: DESIGN CHANGE OF ENGINE OIL COOLER HOUSING**

This document is to inform dealers of the design change to the engine oil cooler housing for the J05 and J08 engines.

**1. RELEVANT MODELS**

All J05 and J08 engines

**2. DESIGN CHANGE**

The casting for the engine oil cooler housing has been revised to include 2 shallow machined grooves on both sides of the engine oil cooler housing. These grooves aid in the retention of liquid gasket used during engine production. This changed the appearance of the engine oil cooler housing but does not affect function or applicability.

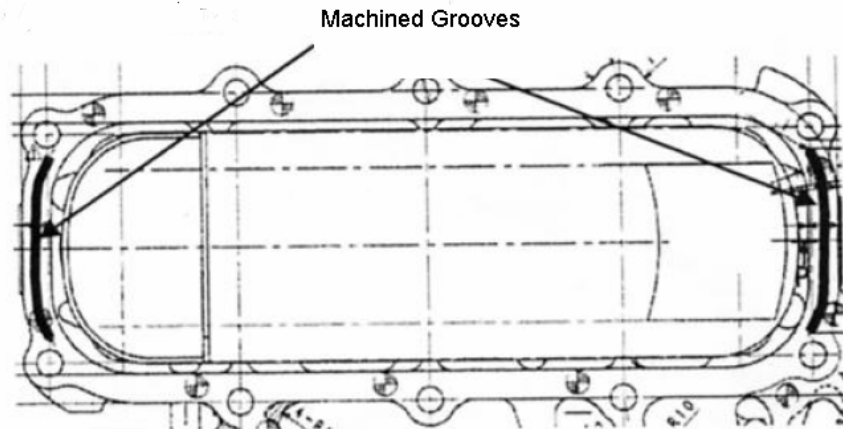

**3. EFFECTIVE DATE**

The use of the oil cooler housing that contains the machined grooves started in June 2005 beginning with the following engine serial numbers.

| Engine Model | Engine Serial Number |
|--------------|----------------------|
| J05D-TA      | 13894                |
| J08E-TA      | 14875                |
| J08E-TB      | 11131                |

**4. INTERCHANGEABILITY**

Engine oil cooler housings with or without the grooves are fully interchangeable. The part numbers have not changed J05 = 157201100A, J08 = 157201400A