

Safety Recall: 2014–20 MDX Rear Subframe Reinforcement

APPLIES TO

Year	Model	Trim Level	VIN Range
2014–20	MDX	ALL	Check iN VIN status for eligibility.

BACKGROUND

Vehicles operated in regions where de-icing agents are heavily used may experience premature corrosion at the rear subframe suspension mounting points. If the mounting points for the rear control arm or lower arm fail, the rear wheel(s) can become misaligned or inadequately retained, which could adversely affect vehicle handling, stability, and braking performance, increasing the risk of a crash or injury.

OWNER NOTIFICATION

Owners of affected vehicles will be sent a notification of this campaign.

Do an iN VIN status inquiry to make sure the vehicle is shown as eligible.

Some vehicles affected by this campaign may be in your new or used vehicle inventory.

Failure to repair a vehicle subject to a recall or campaign may subject your dealership to claims or lawsuits from the vehicle owner and/or anyone else harmed as a result of such failure. To verify if a vehicle in inventory is affected, do a VIN status inquiry before selling it.

CORRECTIVE ACTION

Install a rear subframe reinforcement kit.

CLIENT INFORMATION: The information in this bulletin is intended for use only by skilled technicians who have the proper tools, equipment, and training to correctly and safely maintain your vehicle. These procedures should not be attempted by “do-it-yourselfers,” and you should not assume this bulletin applies to your vehicle, or that your vehicle has the condition described. To determine whether this information applies, contact an authorized Acura automobile dealer.

WARRANTY CLAIM INFORMATION

2014–2016 MDX

NOTE: Select the appropriate repair and template.

Install Subframe Reinforcement Kit Only

Operation Number	Description	Flat Rate Time	Defect Code	Symptom Code	Template ID	Failed Part Number
4170A8	Install subframe reinforcement kit Only	1.1 hr	6JR00	AOT00	B26049A	50300-TZ5-A02

Install Subframe Reinforcement Kit and Needed Supplemental Repairs

NOTE: For template B, add the appropriate weld nut washer bracket LON and/or brake wire bracket LON to the claim form.

4170A8	Install subframe reinforcement kit	1.1 hr	6JR00	AOT00	B26049B	50300-TZ5-A02
4180A0	Install one weld nut washer bracket	0.2 hr	Add if repair was required.			
4180A1	Install both weld nut washer brackets	0.4 hr				
4190A0	Install one brake wire bracket	0.1 hr				
4190A2	Install both brake wire brackets	0.2 hr				

Replace Subframe and install Reinforcement Kit

NOTE: Before replacing the subframe, take clear photos of the VIN plate and the damaged subframe panel showing why the supplemental repair procedures A1-A3 cannot be installed.

4171G5	AWD – Replace rear subframe and install reinforcement kit (includes alignment and photos)	4.7 hr	6JR00	AOT00	B26049C	50300-TZ5-A02
	2WD – Replace rear subframe and install reinforcement kit (includes alignment and photos)	3.7 hr	6JR00	AOT00	B26049D	50300-TZ5-A02

2017–2020 MDX

NOTE: Select the appropriate repair and template.

Install Subframe Reinforcement Kit Only

Operation Number	Description	Flat Rate Time	Defect Code	Symptom Code	Template ID	Failed Part Number
4170A8	Install subframe reinforcement kit Only	1.1 hr	6JR00	AOT00	B26049E	50300-TZ5-305

Install Subframe Reinforcement Kit and Needed Supplemental Repairs

4170A8	Install subframe reinforcement kit	1.1 hr	6JR00	AOT00	B26049F	50300-TZ5-305
4180A0	Install one weld nut washer bracket	0.2 hr				

4170A8	Install subframe reinforcement kit	1.1 hr	6JR00	AOT00	B26049G	50300-TZ5-305
4180A1	Install both weld nut washer bracket	0.4 hr				

Replace Subframe and install Reinforcement Kit

NOTE: Before replacing the subframe, take clear photos of the VIN plate and the damaged subframe panel showing why the supplemental repair procedures A1-A3 cannot be installed.

4171G5	AWD – Replace rear subframe and install reinforcement kit (includes alignment and photos)	4.7 hr	6JR00	AOT00	B26049H	50300-TZ5-305
	2WD – Replace rear subframe and install reinforcement kit (includes alignment and photos)	3.7 hr	6JR00	AOT00	B26049J	50300-TZ5-305

PARTS INFORMATION

Part Name	Part Number	Quantity
Rear Subframe Reinforcement Kit – (2WD)	50390-TJZ-305	1
Rear Subframe Reinforcement Kit – (AWD)	50390-T6Z-305	1

REQUIRED MATERIALS

Part Name	Part Number	Quantity
Brake Cleaner (Restricted for CA, CO, CT, DE, MD, NH, NY, RI, UT) (Restricted in NJ effective August 2026)	08700-9200	1
Brake Cleaner 10% VOC	08700-9222A	
Brake Cleaner SCAQMD Compliant (CA Compliant)	08700-SBPCB	
Anti-Corrosion Wax	07AAK-SJCA120	1 (1 can will service 10 vehicles)

TOOL INFORMATION

Tool Name	Tool Number	Quantity
INSTALLER, RIVNUT M8 (For 2WD only)	07AAE-SJCA100	1
RIVETER, AIR	07AAE-TG7A100	1

NOTE: Tools have been auto-shipped to each Acura dealer.

REPAIR PROCEDURE

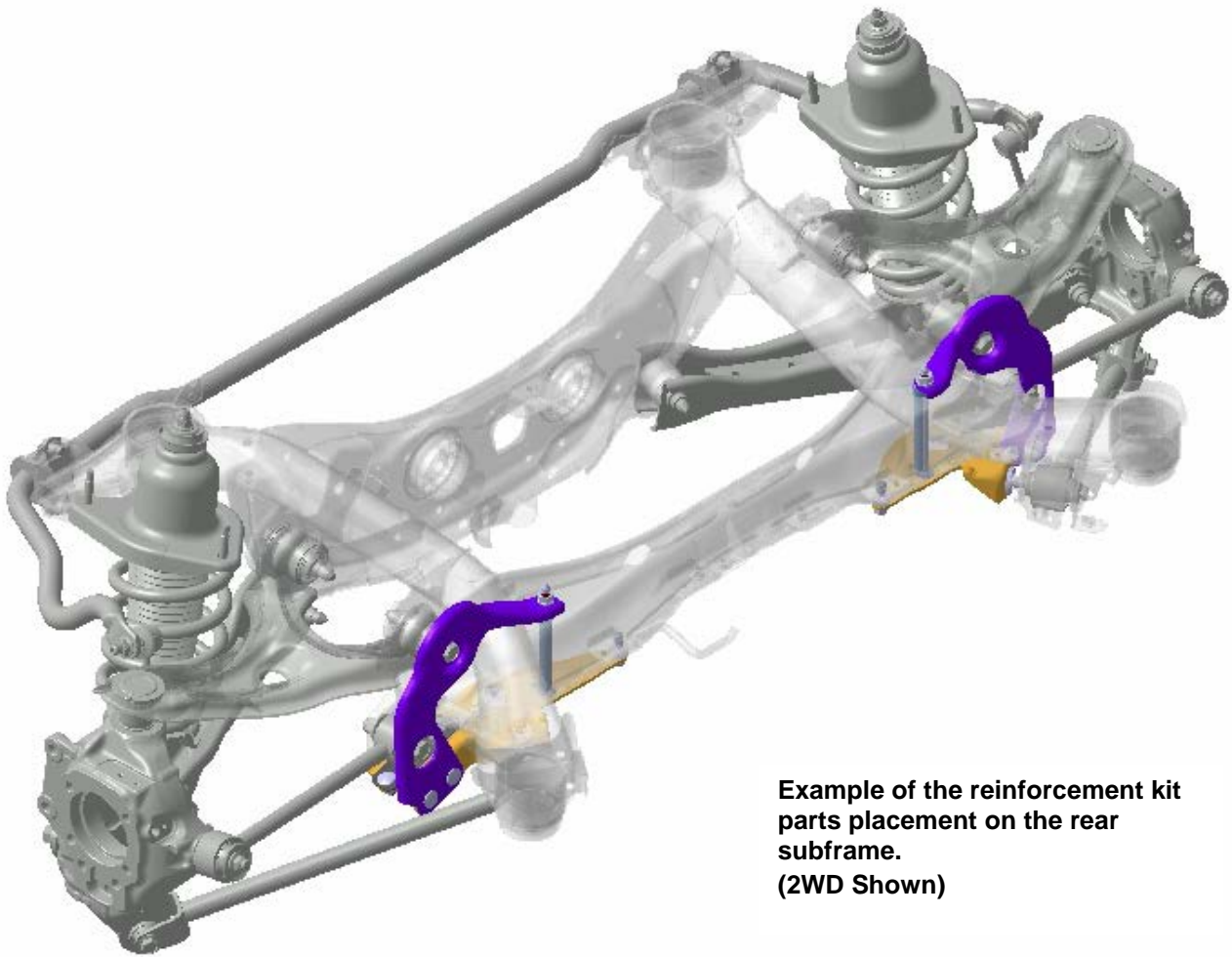

Example of the reinforcement kit parts placement on the rear subframe.
(2WD Shown)

1. Lift the vehicle, see [Lift and Support Points](#).
2. Remove the rear wheels.
3. **4WD Models Only:**

Remove and discard the rear differential outboard mounting bolts on both sides of the front crossmember, then proceed to step 5.

NOTE: If these bolts do not come out, or the weld nuts or threads are damaged, refer to [Procedures A1-A2](#) in the REAR FRAME REINFORCEMENT KIT – SUPPLEMENTAL REPAIRS section at the end of this bulletin.



↑
FRONT OF
VEHICLE

4. **2WD Models Only:**

Install **M8** rivet nuts (see the [Using the Rivet Nut Installation Tool](#) Job Aid) into the locations shown in the underside of the front crossmember portion of the rear subframe, then proceed to step 5.

NOTE: If the mounting holes in the subframe are too corroded to hold the Rivet nuts, refer to [Procedure A3](#) in the REAR FRAME REINFORCEMENT KIT – SUPPLEMENTAL REPAIRS section at the end of this bulletin.

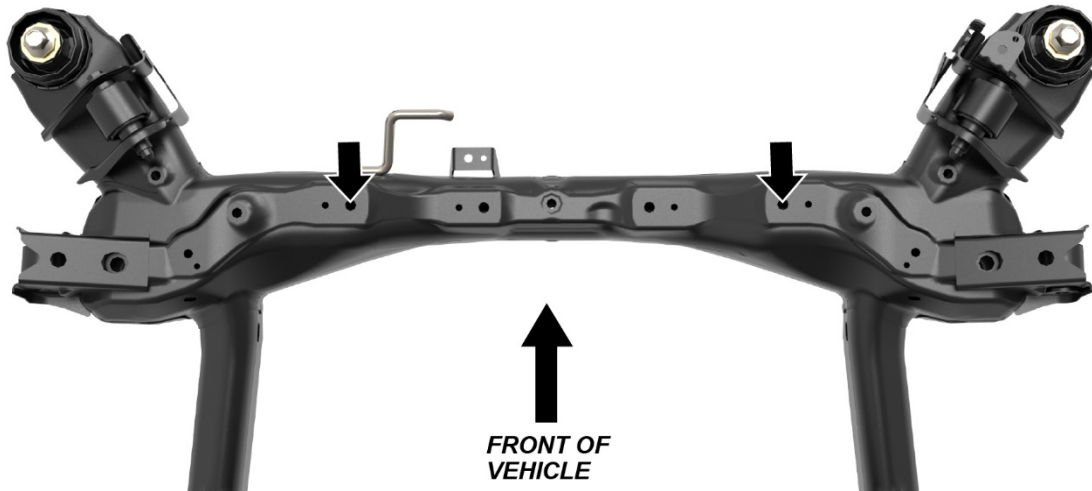

5. **2017–2020 Models:**

Go to step 6.

2014–2016 Models Only:

Remove the bolts that secure the parking brake wires to the subframe, then move the cables to the side.

NOTE: If these bolts do not come out, or the weld nuts or threads are damaged, refer to [Procedure B](#) in the REAR FRAME REINFORCEMENT KIT – SUPPLEMENTAL REPAIRS section of this bulletin.



6. Clean dirt, debris, and rust off the subframe in the areas shown, then wipe down with brake cleaner to prepare the areas for the reinforcement kit installation.

NOTE:

- Ensure that both inner and outer surfaces of the control arm mounting brackets are free from debris.
- Use a flat screwdriver and compressed air to remove debris from the inner bracket surfaces as needed.

- 6.1 Clean the upper arm front bracket mounting area and front cross member upper area.

LEFT SIDE



RIGHT SIDE



6.2 Clean the control arm bracket area, lower arm rear bracket face, and the cross member lower differential mount area (2WD only).

LEFT SIDE



RIGHT SIDE



7. Right Side:

Install the collar into the hole in the top of the subframe front crossmember, just inboard from the upper arm mount.

7.1 Insert the collar (1) into the top of the crossmember and ensure the head sits flush with the top of the crossmember.

NOTE: If there is not enough clearance to insert the collar into the subframe hole, see step 7.2 for additional information.

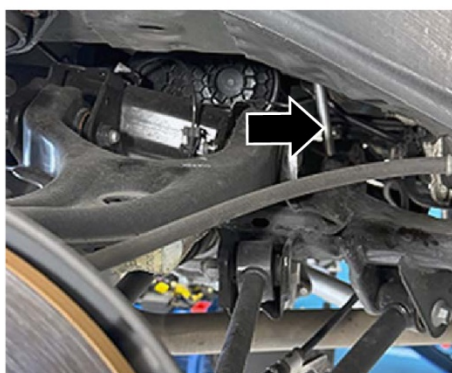
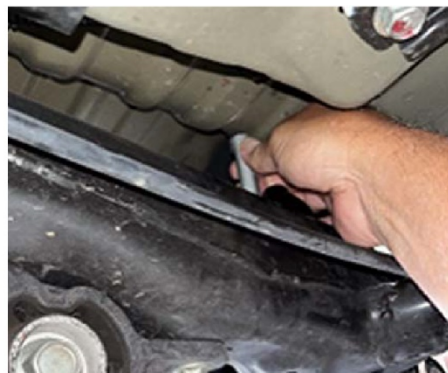
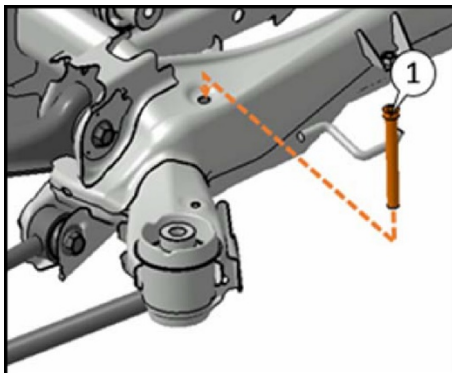

7.2 If there is not enough clearance to slide the collar into the hole, loosen the forward mounting bolt for the rear crossmember and use a pry bar to force the subframe down for more clearance. Once the collar is installed, install a new subframe mounting bolt and torque it to **132 N-m (97 lb-ft)**.

NOTE: **Do not** remove both forward subframe mounting bolts at the same time or an alignment will be required.



**REAR CROSSMEMBER
MOUNTING BOLT -
FORWARD LOCATION**
132 N-m (97 lb-ft)
Replace.

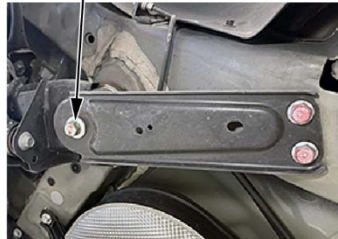

8. Make 4 cardboard masking pieces by cutting off the tabs of the cardboard parts box inserts and then fold the pieces into thirds in a "Z" shape as shown.



CARDBOARD PARTS BOX
Cut off tabs.

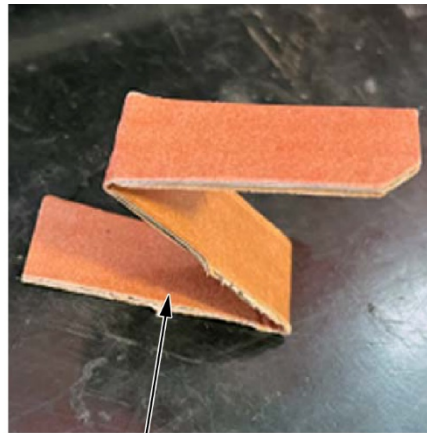

Fold pieces into thirds in a "Z" shape.

9. Insert the cardboard pieces around the control arm bushing to protect the rubber area of the bushing.



10. Apply spray wax on the inner and outer surfaces of the control arm bracket area. If overspray occurs on the stiffener bracket, wipe the surface with brake cleaner.

NOTE: Leave the cardboard in place until the final spray wax step is completed.



SPRAY WAX

11. Remove and discard the upper arm front bolt.

NOTE: If the weld nut is damaged or becomes separated from the subframe, refer to [Procedure C](#) in the REAR FRAME REINFORCEMENT KIT – SUPPLEMENTAL REPAIRS section at the end of this bulletin.



UPPER ARM FRONT BOLT
Replace.

FRONT OF VEHICLE
➔

12. Install the upper stiffener bracket to the subframe using a new 14x90 mm flange bolt. Snug the bolt but **do not** tighten to final torque.

STIFFENER BRACKET

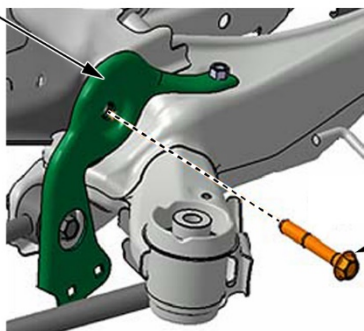

14 x 90 FLANGE BOLT
Snug bolt, do not
tighten to final torque.
Replace.

13. Remove and discard the lower arm A bolt.

NOTE: If the weld nut is damaged or becomes separated from the subframe, refer to [Procedure D](#) in the REAR FRAME REINFORCEMENT KIT – SUPPLEMENTAL REPAIRS section at the end of this bulletin.



14. Install a new **12x100 mm** flange bolt from the kit into the lower arm mount. Load the suspension with the vehicle's weight and tighten the bolt to the specified torque **83 N·m (61 lb-ft)**.

NOTE: The new bolt tip will protrude beyond the weld nut.

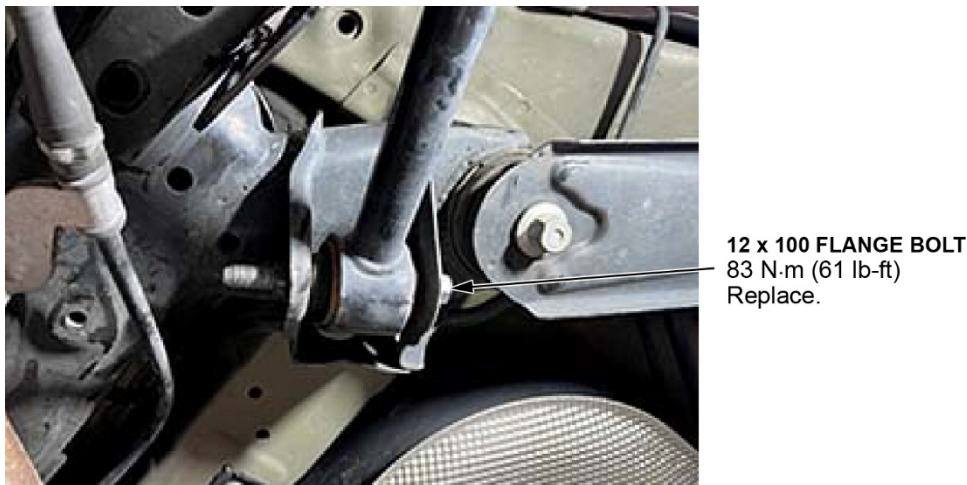

15. Install a spacer on the lower arm A **12x100 mm** flange bolt.

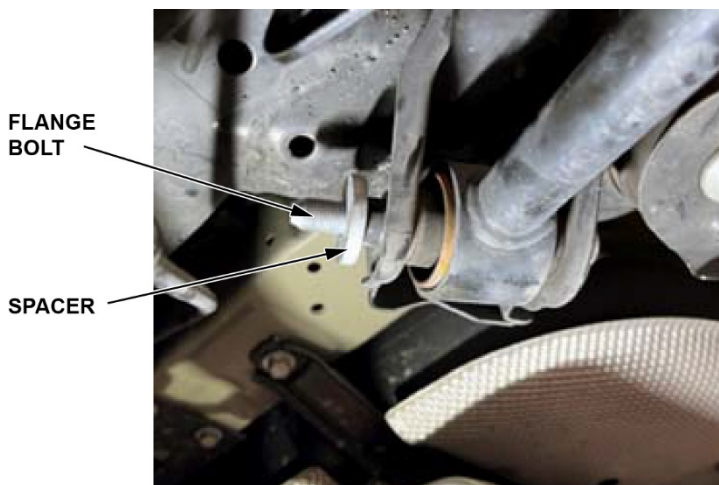

16. Insert the spacer into the lower stiffener bracket.



17. Place a carriage bolt in the lower stiffener in the location shown, then loosely put a flange nut on the underside to keep it in place during installation.

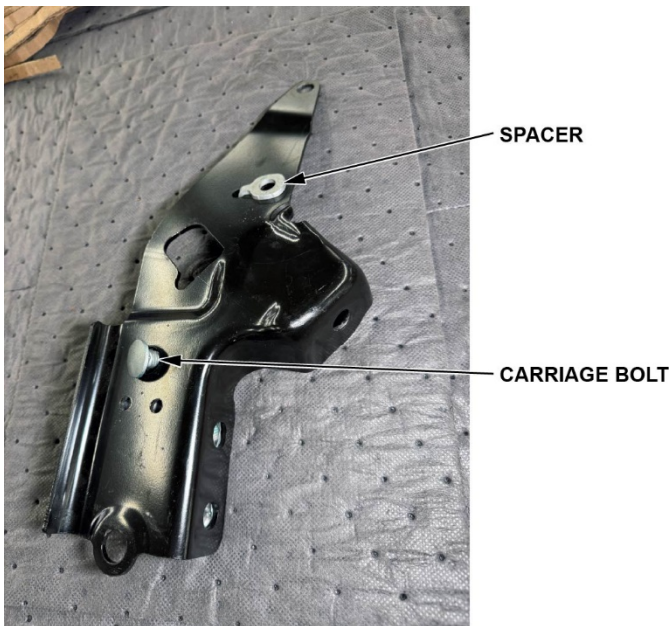

18. For vehicles with dual exhaust only, remove the rear exhaust hangers on the left and right sides.

DUAL EXHAUST ONLY

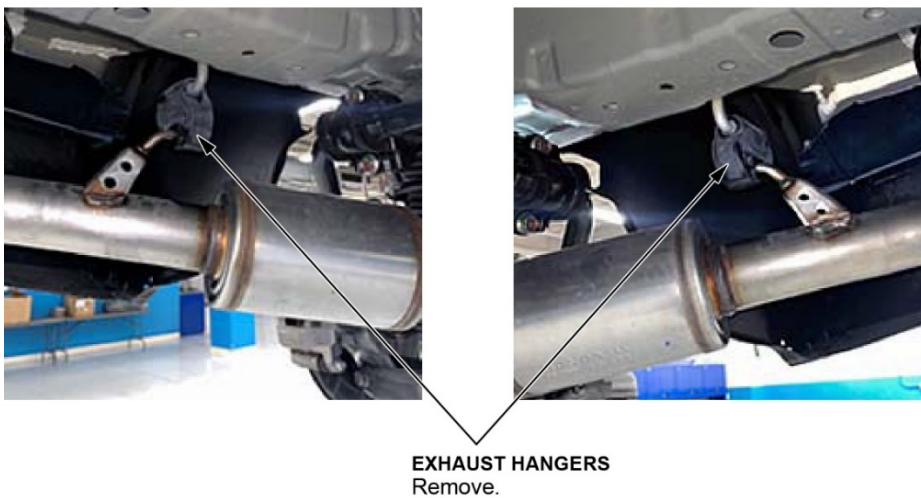

19. Install the lower stiffener bracket to the subframe. Loosely install the **12 mm** flange nut to the lower arm A bracket flange bolt, then install the **10x135 mm** flange bolt through the collar and into the upper stiffener plate.



10 x 135 FLANGE BOLT 12 mm FLANGE NUT Loosely install. M10 FLANGE BOLT

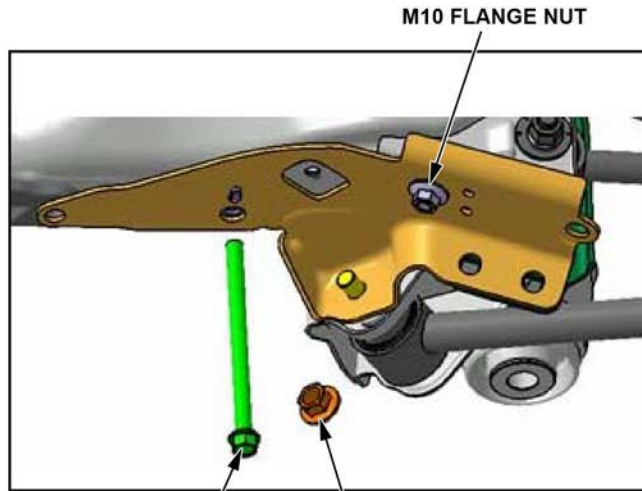

M10 FLANGE NUT
10 x 135 FLANGE BOLT 12 mm FLANGE NUT Loosely install.

20. **4WD Models Only** (2WD Models go to step 21):

Install the **10x30 mm** flange bolt into the subframe until. Do not tighten to final torque at this time.

4WD ONLY

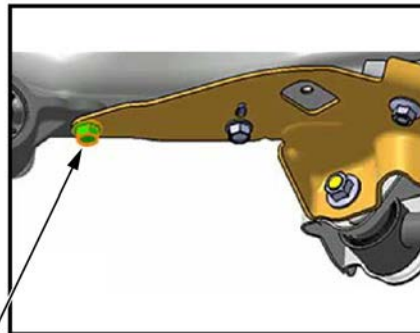

10 x 30 FLANGE BOLT

21. **2WD Models Only:**

Install the spacer between the lower stiffener and front subframe cross member, then install the **8x30 mm** flange bolt into the rivet nut that was installed earlier. **Do not** tighten to final torque at this time.

2WD ONLY

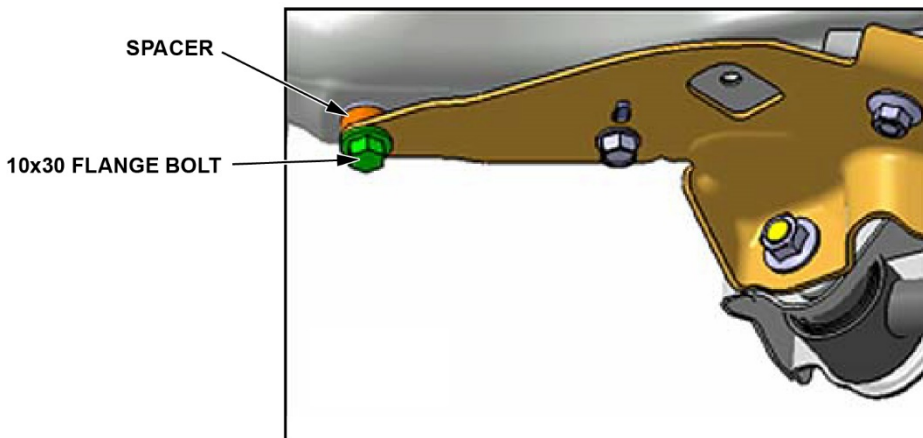

SPACER
10x30 FLANGE BOLT

22. Push up slightly on the carriage bolt so it sticks up through the lower control arm bracket, then slide the insert plate above the lower control arm bracket so that the square slot of the plate engages with the square head of the carriage bolt (rotating the carriage bolt slightly may help with engagement).

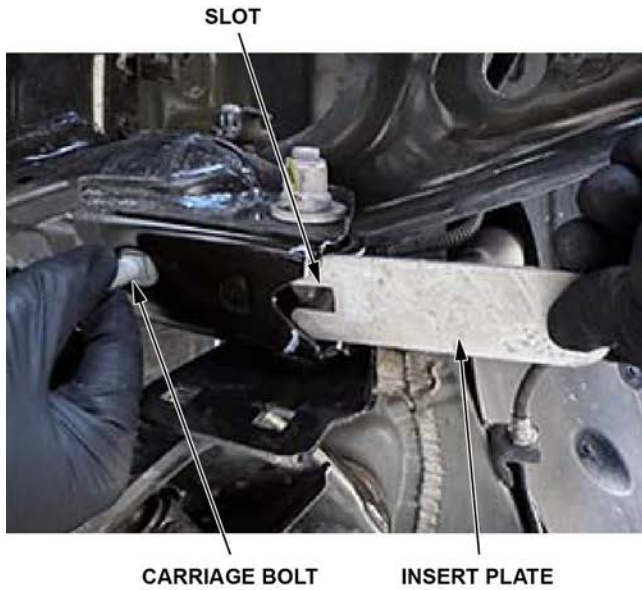

23. Secure the insert plate to the lower stiffener with **10x22 mm** carriage bolts and **10 mm** flange nuts and tighten until snug.



**10x30 CARRIAGE BOLTS
WITH 10mm FLANGE NUTS**

24. Secure the upper stiffener to the lower stiffener with two **10x22 mm** carriage bolts and two **10 mm** flange nuts.
NOTE: Make sure the square head of the carriage bolt is seated in the square hole in the upper stiffener plate.



**10x30 CARRIAGE BOLTS
WITH 10mm FLANGE NUTS**

25. Load the suspension with the vehicle's weight, then torque all bolts to specification in the following sequence (Repeat for both sides):

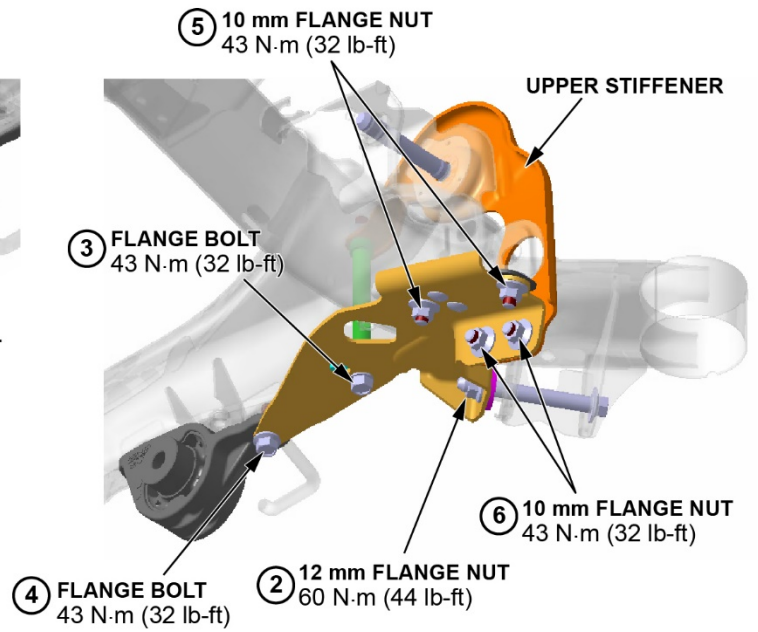
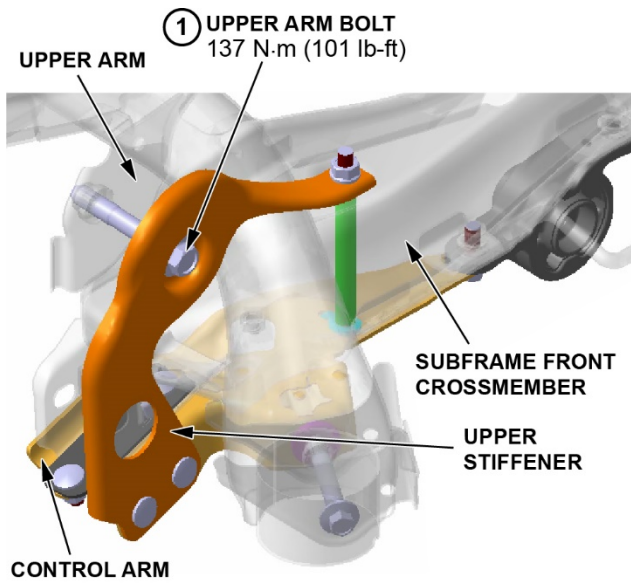

26. **2014–16 MDX only:**

Install the parking brake wire bracket and bolt, then torque to **21 N·m (15 lb-ft)**.

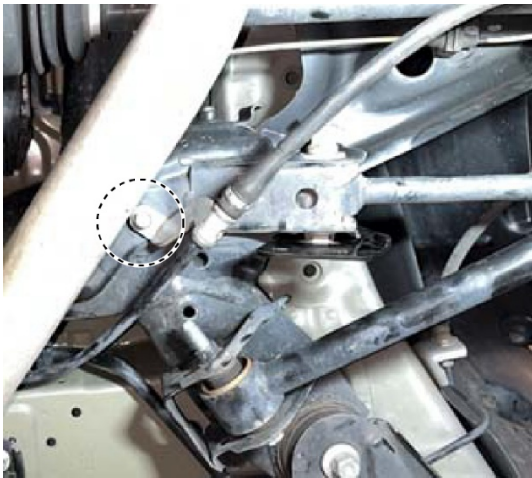

27. Using the punched holes in the lower stiffener as a guide, drill two **5 mm** holes through the subframe control arm bracket and the inserted plate.

5 mm HOLES



28. Install the rivets provided into each of the drilled holes.

NOTE: Make sure the rivet flange is fully seated against the lower stiffener bracket prior to setting the rivet.



29. Install the cardboard masking to protect the rubber bushing, then apply additional anti-corrosion wax around the rivet area.

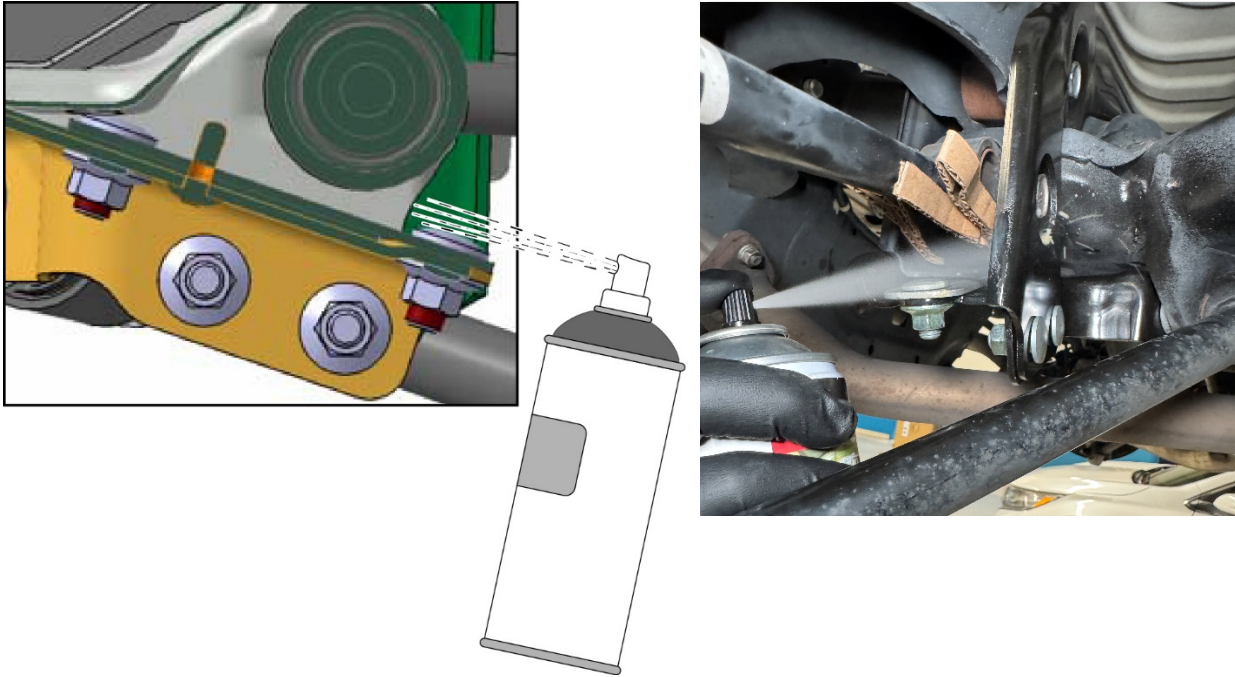

30. Remove the cardboard masking from the control arm bushing.
31. Repeat the repair process for the opposite side of the vehicle.
32. Install the rear wheels and torque to **127 N·m (94 lb-ft)**.

REAR FRAME REINFORCEMENT KIT – SUPPLEMENTAL REPAIRS (AS NEEDED)

Follow the information listed in each section to assist with resolving any of these special conditions.

- **Procedure A1 - Subframe Front Crossmember Differential Mount Bolt Removal:** Weld nut threads are stripped, or the bolt breaks.
- **Procedure A2 - Subframe Front Crossmember Differential Mount Bolt Removal:** Weld nut breaks loose from the inside of the subframe.
- **Procedure A3 - Subframe Front Crossmember Differential Mount Bolt Removal:** Rivet nut cannot be installed into the subframe due to corrosion around the mounting hole (2WD Only).
- **Procedure B (2014–16 MDX only) – Parking Brake Wire Bolt Removal –** Weld nut or subframe corrosion requires bracket to be relocated.
- **Procedure C - Upper Arm Front Bolt Removal –** Weld nut is damaged or separated from the subframe.
- **Procedure C - Lower Arm A Bolt Removal –** Weld nut is damaged or separated from the subframe.
- **Procedure E - Replace Rear Subframe –** Subframe cannot be repaired using steps A1-A3.

Procedures A1-A3 - Subframe Front Cross Member – Differential Mount Bolt Removal

NOTE: If the subframe cannot be repaired using procedures A1-A3, the subframe must be replaced.

Part Name	Part Number	Quantity
Frame Insert Washer	90344-SJC-305	1
Special Bolt 10X62	90324-SJC-305	1
Flange Nut 10MM	94050-10000	2
Guide Wire M10X1.25	07AAG-TZ5A200	1

- Procedure A1: Stripped/Damaged Threads in Weld Nut or Broken Bolt.
- Procedure A2: Broken/Separated Weld Nut from Subframe.
- Procedure A3: Rivet nut cannot be installed due to corrosion around the mounting holes (2WD Only).

Procedure A1 - Stripped/Damaged Threads in Weld Nut or Broken Bolt.

1. Drill a **12mm** hole through the existing weld nut.

NOTE: If bolt is broken, remove or drill out the bolt, then drill through the existing weld nut.

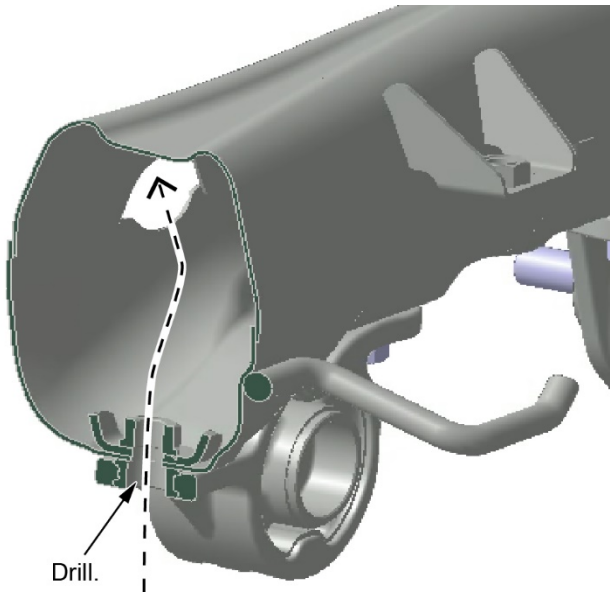

BOLT SPECIAL 10x62
P/N: 90324-SJC-305

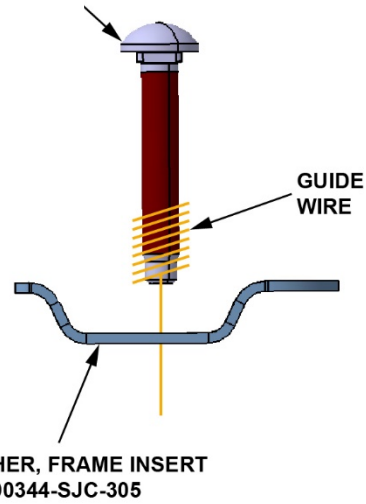

2. Continue with the repair procedure through step 24.
3. Feed the guide wire upward through the drilled-out weld nut and out through the access hole in the rear side of the front cross member.

4. Pass the guide wire through the washer (P/N: 90344-SJC-305) and thread it onto the carriage bolt (P/N: 90324-SJC-305).

NOTE:

- When inserting the washer in the RIGHT SIDE, insert the short side first (after passing the guide wire through the 12 mm hole).

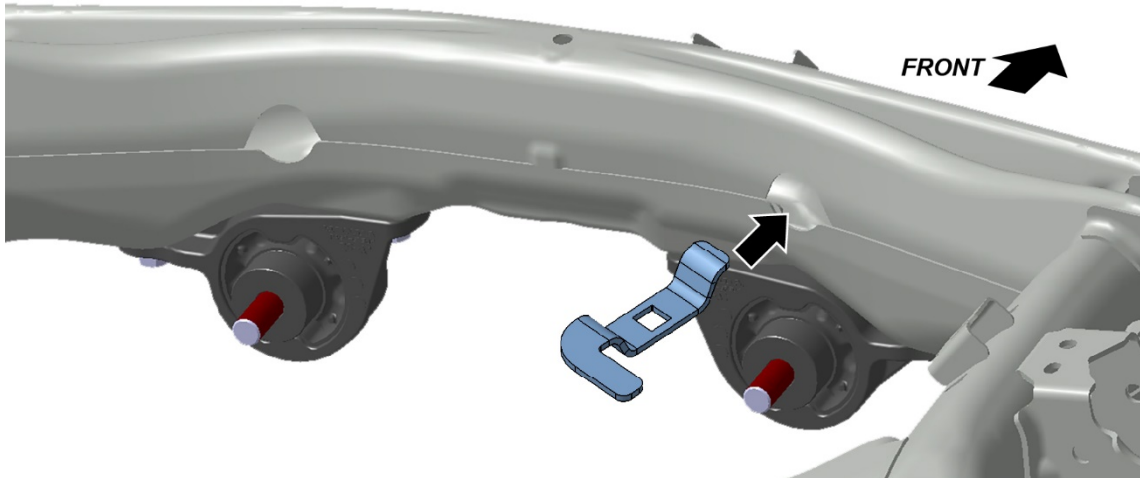

- When inserting the washer in the LEFT SIDE, insert the long end first (after passing the guide wire through the 12 mm hole)

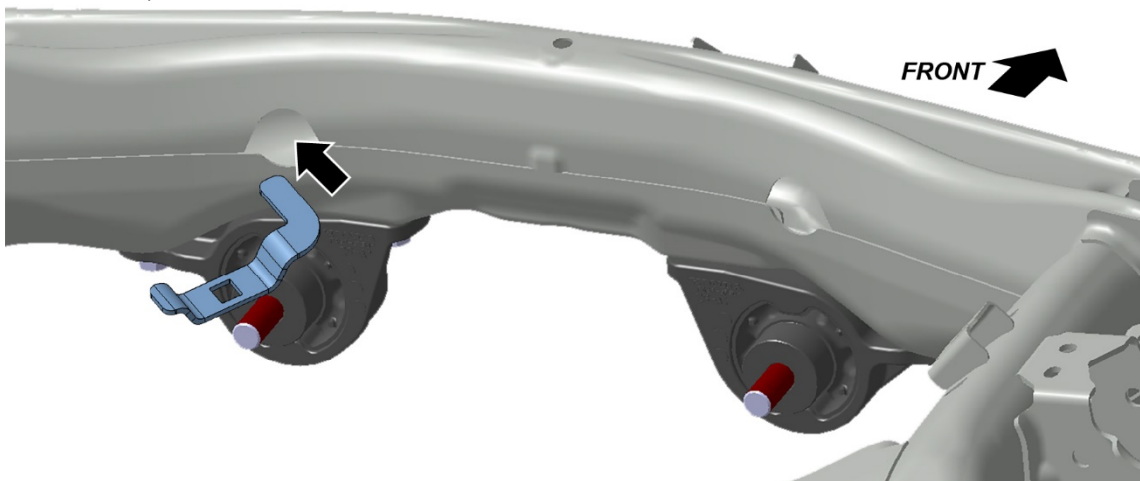

5. Gently feed the washer and carriage bolt through the cross-member access hole. Continue to pull the guide wire downwards until the carriage bolt is pulled down through weld nut and is exposed through the differential mount area.

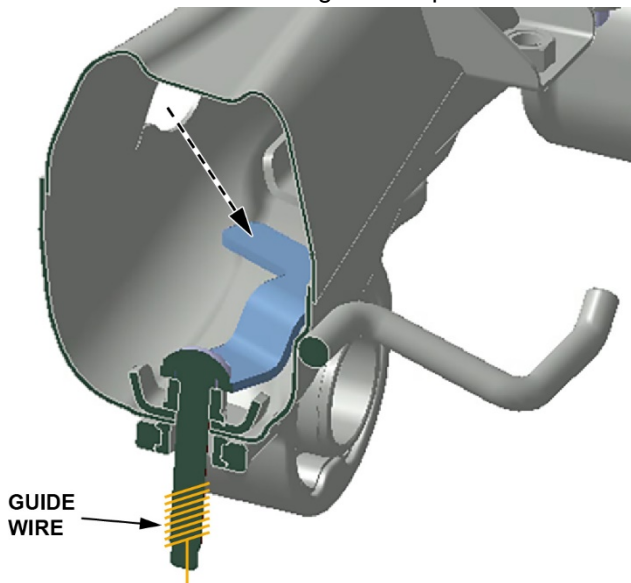

6. Rotate the carriage bolt while pulling downwards to engage the square anti-rotation feature into the washer, then remove the guide wire.
7. Replace the old **M10** bolt with the **M10** flange nut (P/N: 94050-10000) and torque to **49 N.m (36 lb-ft)**. Install a second **M10** flange nut as a lock-nut and torque to **49 N.m (36 lb-ft)**.

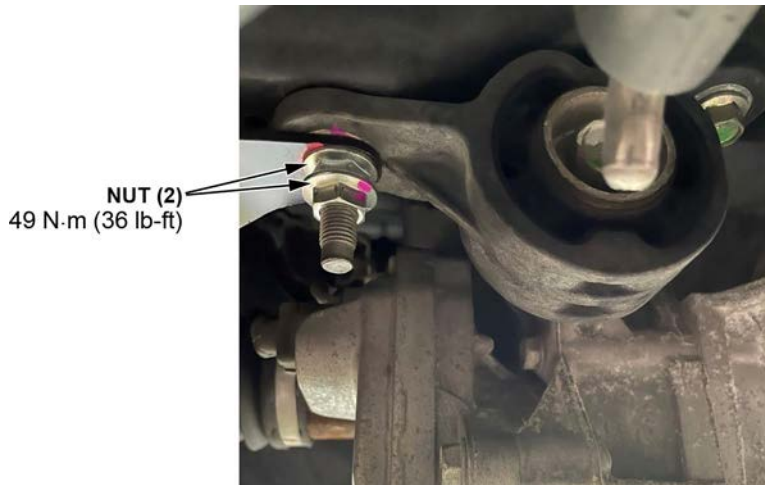

Procedure A2 - Broken/Separated Weld Nut from Subframe

1. Remove the broken weld nut from the subframe.

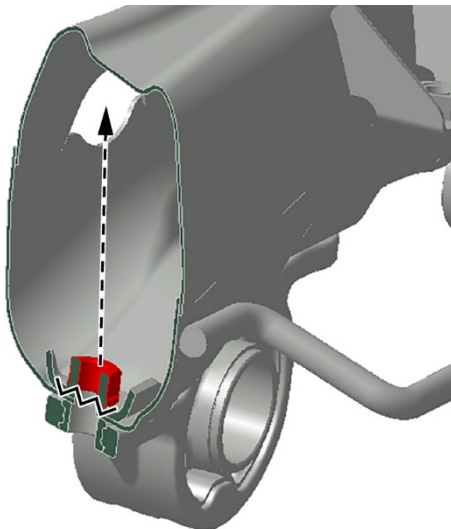

2. Continue with the repair procedure through step 24.
3. Cut the washer frame insert (P/N: 90344-SJC-305) as shown.

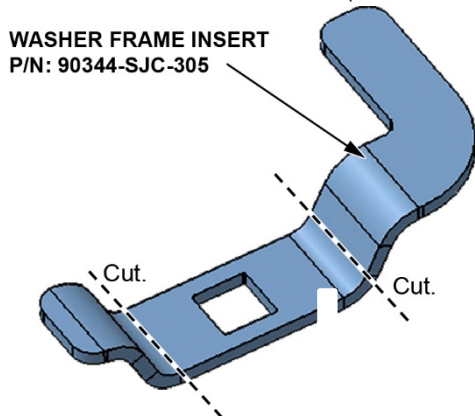

4. Feed the guide wire upward through the existing subframe hole and out through the access hole in the rear side of the front crossmember.

5. Pass the guide wire through the modified washer and thread it onto the carriage bolt (P/N: 90324-SJC-305).

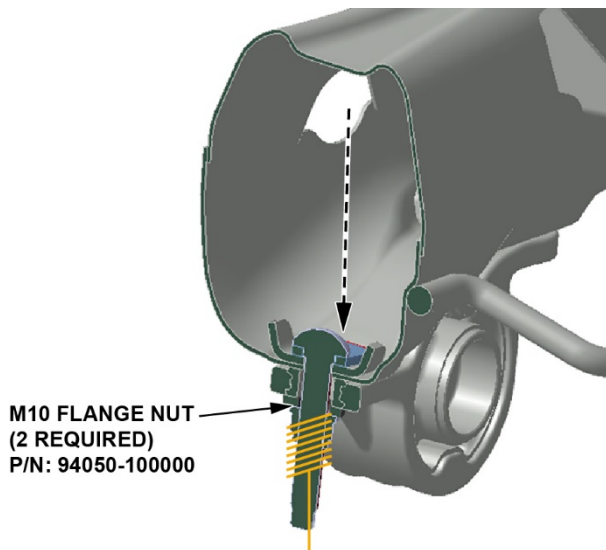

6. Gently feed the washer and carriage bolt through the crossmember access hole. Continue to pull the guide wire downwards until carriage bolt is pulled down through weld nut and is exposed through the differential mount area.
7. Rotate the carriage bolt while pulling downwards to engage square anti-rotation feature into the washer, then remove the guide wire.
8. Replace the old **M10** bolt with the M10 flange nut (P/N: 94050-10000) and torque to **49 N.m (36 lb-ft)**. Install a second **M10** flange nut as a lock-nut and torque to **49 N.m (36 lb-ft)**.

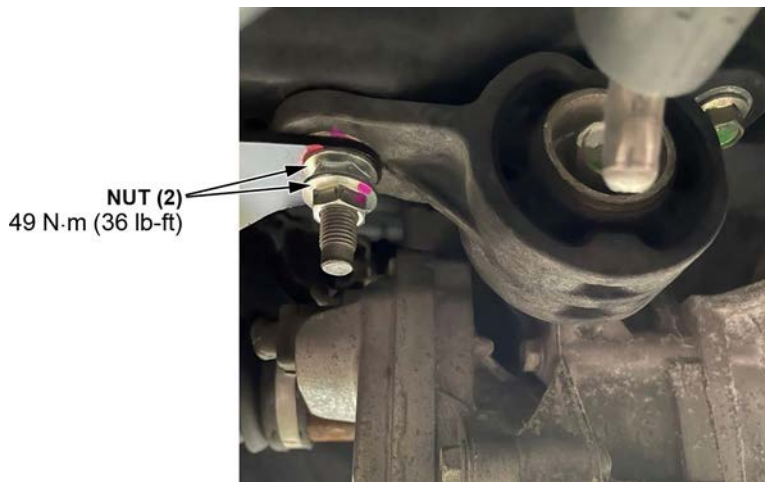

Procedure A3 - Rivet nut cannot be installed due to corrosion around mounting hole (2WD Only)

1. Cut the washer frame insert (P/N: 90344-SJC-305) as shown.

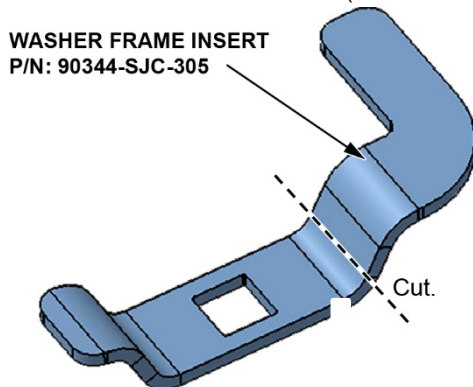

2. Feed the guide wire upward through the existing subframe hole and out through the access hole in rear side of front crossmember.

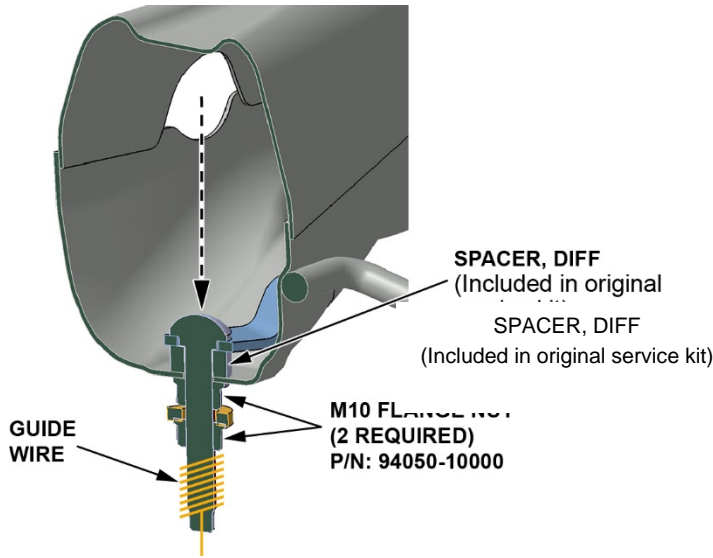

3. Pass the guide wire through the differential spacer (supplied with original service kit) and the cut washer frame insert and thread it onto the carriage bolt (P/N: 90324-SJC-305).
4. Gently feed the differential spacer, washer and the carriage bolt through the crossmember access hole. Continue to pull the guide wire downwards until the carriage bolt is pulled down through the hole in the subframe crossmember.
5. Rotate the carriage bolt while pulling downwards to engage the square anti-rotation feature into the washer, then remove the guide wire.
6. Torque the **M10** flange nut (P/N: 94050-10000) to **49 N.m (36 lb-ft)**.
7. Continue with the repair procedure through step 24.
8. Discard the **M8** flange bolt. Replace it with the **M10** flange nut (P/N: 94050-10000). Install to the carriage bolt and torque to **49 N.m (36 lb-ft)**.

Procedure B – Parking Wire Bracket Repair - (2014–16 MDX Only)

	Part Name	Part Number	Quantity
Right	Bracket C, Brake Wire Right	47523-TZ5-A00	1
	Brake Wire Stay Plate Right	50395-T6Z-A60	1
	Bolt-Wash, 8X16	93401-08016-08	1
	Flange Nut 8MM	94050-08050	1
Left	Bracket C, Brake Wire Left	47563-TZ5-A00	1
	Brake Wire Stay Plate Left	50396-T6Z-A60	1
	Bolt-Wash, 8X16	93401-08016-08	1
	Flange Nut 8MM	94050-08050	1

1. Remove the original parking brake wire bracket from the parking brake wire.
NOTE:
 - **Do not** damage the parking brake wire casing.
 - Cutting may be required to remove the parking brake wire bracket.
2. Continue with the subframe service repair kit installation outlined in the REPAIR PROCEDURE, using the steps below to substitute for step 26.

3. Install the parking brake wire stay plate to the lower stiffener with the flange bolt and torque to **21 N·m (15 lb-ft)**.

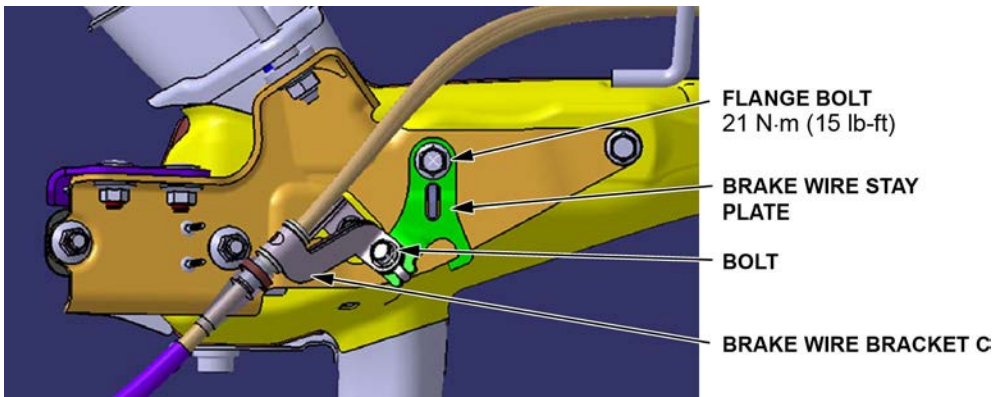

4. Install the new brake wire bracket C onto the parking brake wire.
5. Secure the brake wire bracket C to the brake wire stay plate with the bolt and nut provided.

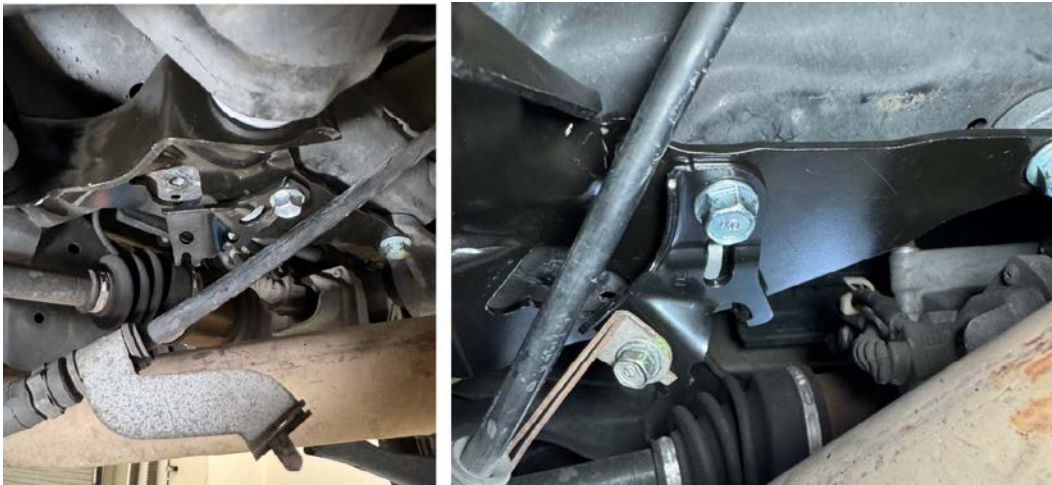

Procedure C - Upper Arm Front Bolt Removal

Part Name	Part Number	Quantity
Self-Lock Nut 14MM	90215-TGV-A00	1

During the removal of the upper arm front bolt, the weld nut may get damaged or become completely separated from the rear subframe. Remove the weld nut from the subframe, then clean and inspect the subframe's surface. Once complete, replace the damaged weld nut with the flange nut (P/N: 90215-TGV-A00) and torque to specification following the procedure outlined in step 25 of the REPAIR PROCEDURE.

NOTE:

- This procedure should only be completed if the weld nut was damaged during the repair procedure.
- Using best shop practices, remove the damaged weld nut from the subframe.



Procedure D - Lower Arm A Bolt Removal

Part Name	Part Number	Quantity
Flange Nut 12MM	90213-3T1-000	1

During the removal of the lower arm A bolt, the weld nut may get damaged or become completely separated from the rear subframe. Remove the weld nut from the subframe, then clean and inspect the subframe's surface. Once complete, replace the damaged weld nut with the flange nut (P/N: 90213-3T1-000) then torque to specification as outlined in step 14 of the REPAIR PROCEDURE.

NOTE:

- This procedure should only be completed if the weld nut was damaged during the repair procedure.
- Using best shop practices, remove the damaged weld nut from the subframe.



Procedure E - Replace Rear Subframe

NOTE: Replace the subframe **only** if it cannot be repaired using supplemental repairs A1-A3.

1. Take clear photos of the VIN plate and the damaged subframe panel showing why the supplemental repair procedures A1-A3 cannot be installed.
2. Replace the rear subframe – [Subframe Removal and Installation](#).