



Safety Recall Action Notice 641 Issue 1 - 02/2026

Subject: Alternator Connector Replacement			
Bulletin Number	Models Affected	VIN Range	Markets Affected
641	Bonneville T100, Bonneville T100 Black, Bonneville T120, Bonneville T120 Black, Bonneville T120 Black DGR Limited Edition, Scrambler 900, Speed Twin 900, Street Scrambler, Street Scrambler Sandstorm, Street Twin, Street Twin Goldline	From VIN AE2011 to BT0245	All Markets

WARNING

Each dealer will be auto-issued two new tools (Wire Stripping Tool T3880188 & Crimping Tool T3880189) which must be used throughout this repair. Do not use any other wire stripping or crimping tools when undertaking this repair.

These tools are to be kept as ongoing service tools and must be retained by the dealer for future repairs where they are needed.

Failure to use the approved tools could result in a poor electrical joint, leading to overheating of the connection.

Failure to follow the advice above could result in serious injury or death.

Background Information

Dealers are requested to replace the alternator to main harness connectors with crimping sleeves and glue lined heat shrink.

Customer Contact Instructions

NOTICE

STOP DELIVERY OF AFFECTED MOTORCYCLES IMMEDIATELY.

DO NOT deliver a motorcycle affected by this Safety Recall Action Notice to a customer until you have completed, or confirmed completion of, the procedures described in this Safety Recall Action Notice.

Delivering a motorcycle subject to an outstanding Safety Recall Action Notice may contravene local or national laws in your market, territory or country.

Triumph subsidiaries and distributors must instigate a Safety Recall Action in their country in accordance with the national recall code of practice. For vehicles in dealer stock, the safety recall MUST be actioned before delivery to the customer.

Dealers are to prioritise repair of customer owned motorcycles before any unsold motorcycles.

Identification of Affected Motorcycles

Bonneville T100, Bonneville T100 Black, Bonneville T120, Bonneville T120 Black, Bonneville T120 Black DGR Limited Edition, Scrambler 900, Speed Twin 900, Street Scrambler, Street Scrambler Sandstorm, Street Twin and Street Twin Goldline motorcycle listed in the above VIN range.

Warranty Claim Instructions

Bulletin Number	Fault Code	Repair Code	Description	Repair Time Allowance
641	025040941	99641	Alternator Connector Replacement	0.33 Hrs

Genuine Parts Information

Bulletin Number	Part Number	Description	Quantity
641	T2503295	Spares Kit, Harness Consisting of: Glue lined heat shrink sleeves kit, Pack of 6 - Qty 1 Crimping sleeve - Qty 3 Screw, PAN/HD, TX M5x0.8x16, ENC - Qty 1 Test wire - Qty 1 Cable tie - Qty 1	1

Parts Ordering Instructions

For Triumph Subsidiary and Overseas Distributor dealers using Triumph Warranty On-Line with Parts Auto Ordering Flag switched on: Order all repair parts by submitting a New Prior through the Warranty On-Line system. Entering the above repair code in a New Prior will automatically add the parts required and labour times for this Safety Recall Action Notice.

For Overseas Distributor dealers NOT using Triumph Warranty On-Line or for Overseas Distributor dealers using Triumph Warranty On-Line with Parts Auto Ordering Flag switched off: Orders should be placed using the normal parts ordering procedure.

Genuine Parts Return

Dealer to retain parts for 90 days. All parts must be stored in a secure, non-public accessed area and correctly identified with a completed warranty label. Thereafter the parts must be rendered unusable prior to scrapping.

Other Instructions

Once completed, please mark the Service Record Book that the requirements of this Safety Recall Action Notice have been complied with.

Before returning the motorcycle to the customer, check that all electronic control modules have the latest calibrations installed using the latest version of the Triumph Diagnostic Tool. Download any updates as necessary.

Alternator Connector Replacement

! WARNING

Make sure that the motorcycle is stabilised and adequately supported.

Do not support the motorcycle on any ancillary component, the exhaust system or any other non-structural parts of the motorcycle frame.

A correctly supported motorcycle will help prevent it from falling.

Failure to follow the advice above could result in serious injury or death.

! CAUTION

If the motorcycle has recently been running, some components may be hot to the touch.

Contact with the hot components may cause damage to exposed skin.

To avoid skin damage, always allow the hot parts to cool before working on the motorcycle.

NOTICE

Once the alternator connector is replaced with crimps, the main harness is permanently connected to the alternator. It is not possible to replace a crimp, or crimp a wire more than once.

Any errors made during crimping cannot be undone.

1. Remove the battery as described in the service manual.
2. Remove the right hand side panel, by grasping the panel firmly in both hands, and pull the panel away from the motorcycle until it clears the three retaining grommets (leaving the grommets in place).

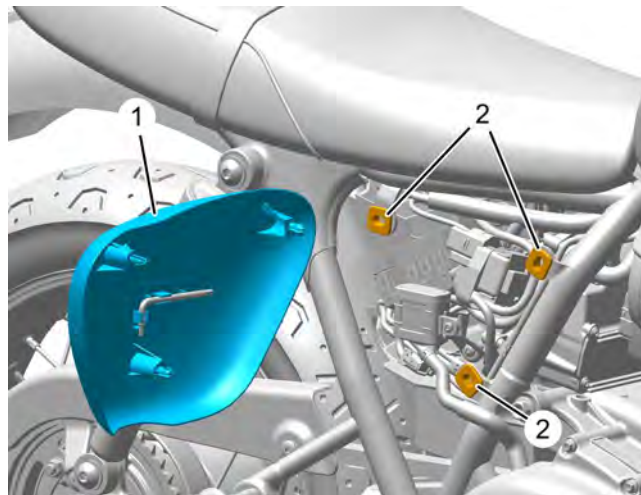

1. **Right hand side panel**
2. **Grommets**
3. Remove the fixings and remove the front sprocket outer cover.

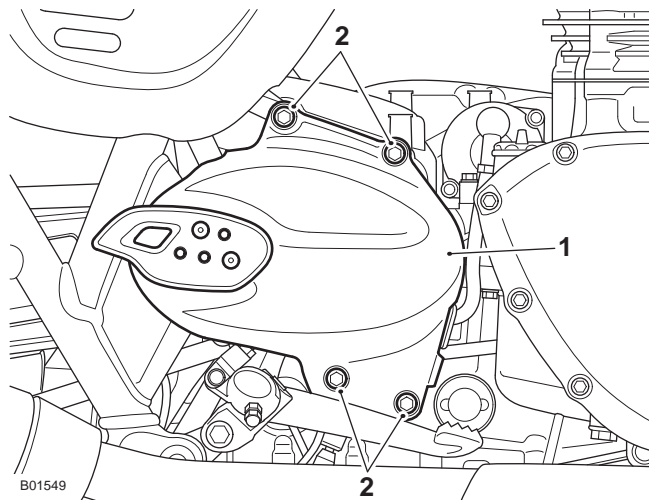

1. Sprocket outer cover
2. Fixings

4. Remove and discard the rear master cylinder reservoir fixing and support the reservoir in an upright position.

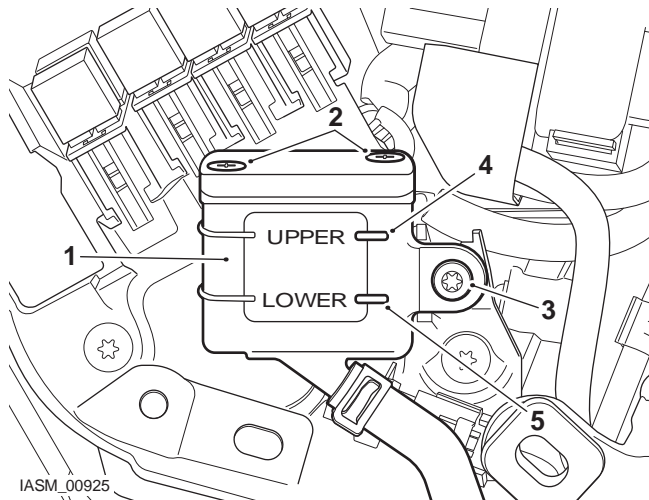

1. Rear brake fluid reservoir
2. Cap fixings
3. Fixing
4. Upper level line
5. Lower level line

5. Detach the crankshaft position sensor electrical connector from the locating feature and disconnect the connector.
6. Detach the alternator harness connector from the front and rear mounting bracket.

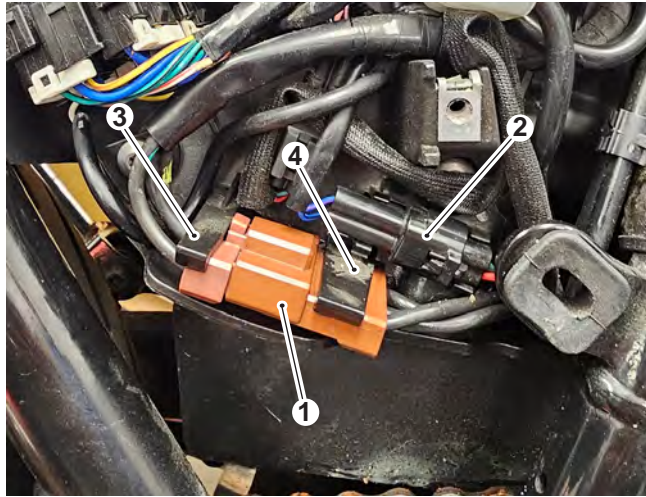

1. Alternator harness connector
2. Crankshaft position sensor electrical connector
3. Rear mounting bracket
4. Front mounting bracket

7. Disconnect the alternator harness connector from the main harness connector.

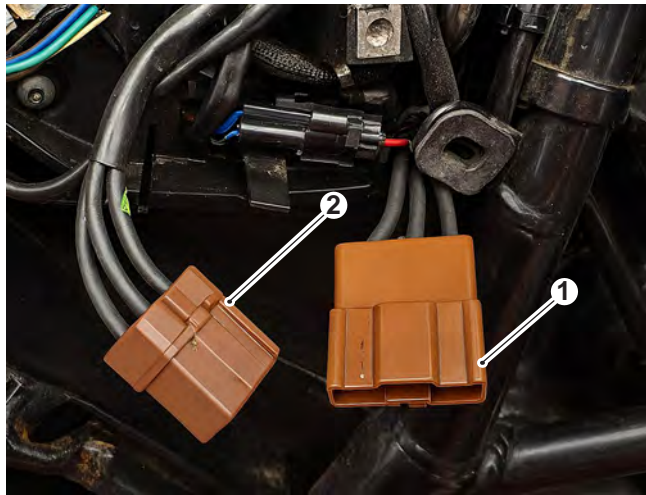

1. Alternator harness connector
2. Main harness connector

8. If fitted, remove and discard the wire alignment clip.

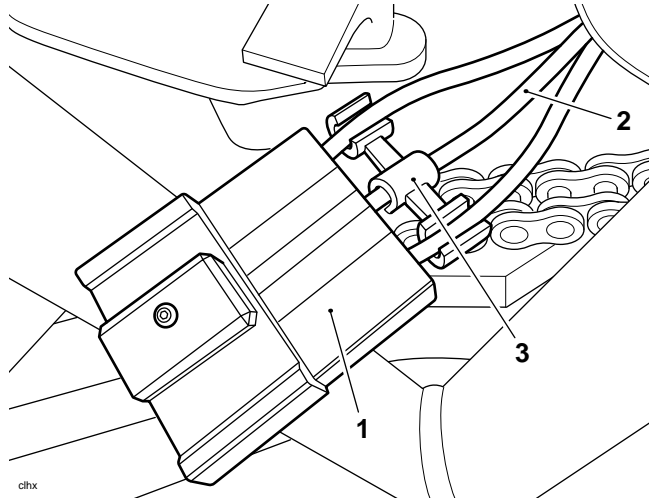

- 1. Alternator harness connector
- 2. Alternator wire
- 3. Wire alignment clip

- 9. Note the routing of the alternator harness and the crankshaft position sensor harness.
- 10. Position the alternator harness connector and the crankshaft position sensor electrical connector to the other side of the frame as shown.

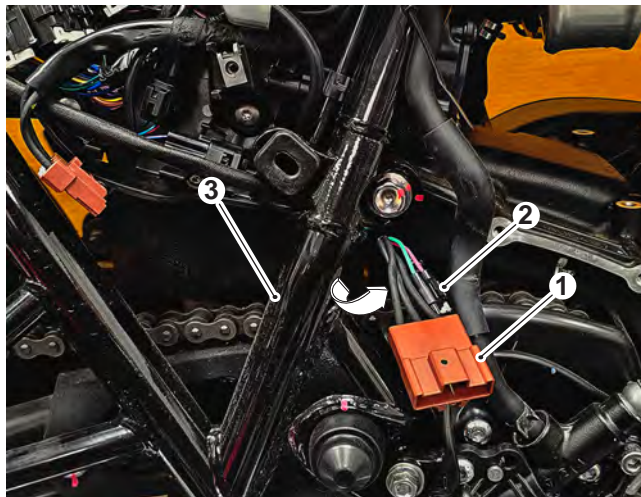

- 1. Alternator harness connector
- 2. Crankshaft position sensor electrical connector
- 3. Frame

- 11. Cut the three wires of the alternator harness connector individually. Make sure the cut is made as close to the rear of the connector as shown.

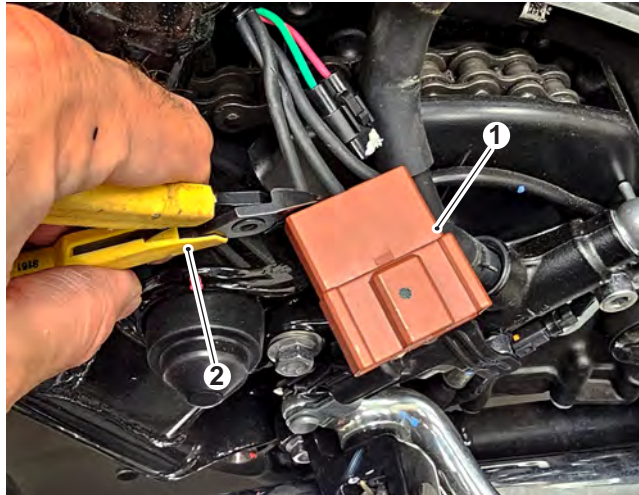

1. Alternator harness connector
2. Wire snips

⚠ WARNING

The wires either side of the (now discarded) connector block each have different diameter insulations – 3.3 mm and 3.78 mm. Always use care when stripping wires. Use only sufficient force to remove the outer insulation without damaging internal wire strands. Each kit contains a practice test wire.

Failure to make sure wire strands are not damaged or stripped away with the insulation could result in overheating of the connection.

Failure to follow the advice above could result in serious injury or death.

NOTICE

Only use wire stripper T3880188 for stripping the wire. Do not use any other wire stripper.

Make sure only 20 mm of insulation is removed from the wire.

12. Use the supplied test wire from the kit and adjust the wire stripper using the rotating knob to match the correct size for the alternator harness wire.
13. Strip 20 mm of insulation from the test wire to make sure the wire strands are not cut while stripping off the insulation.
14. Strip 20 mm of insulation from the end of one alternator harness wire using the wire stripper T3880188 and twist the wire ends.

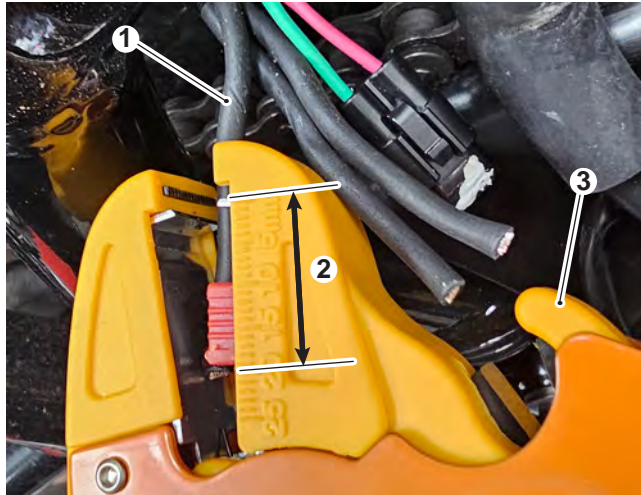

- 1. Alternator harness wire
- 2. 20 mm
- 3. Wire stripper T3880188

15. Wipe and clean the exposed wire strands and the outer surface of the remaining insulation to remove any oil or residue.

NOTICE

Make sure the wire strands are not bent, cut, or damaged when inserting them into the crimping sleeve.

16. Insert the stripped alternator wire fully into the crimp sleeve so it contacts the internal center stop.

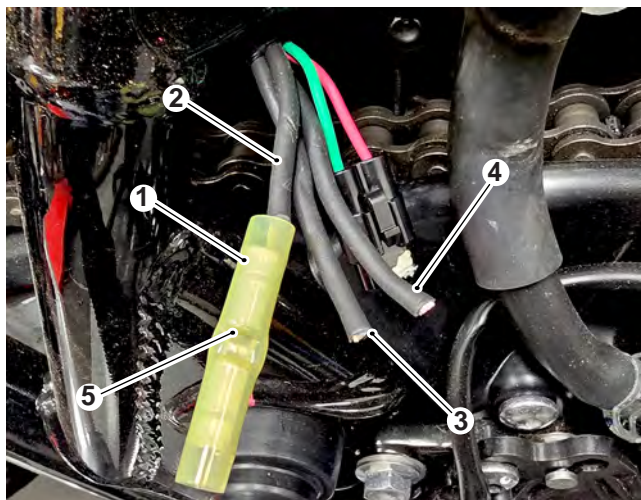

- 1. Crimping sleeve
- 2. Alternator wire one
- 3. Alternator wire two
- 4. Alternator wire three
- 5. Center stop

NOTICE

Use only crimping tool T3880189 for crimping. Do not use any other crimping tool.

- 17. Position the crimping sleeve within the yellow crimping feature of the crimping tool T3880189, make sure the terminal is centered in the crimping jaws.
- 18. Squeeze the crimping tool T3880189 handles until the tool releases. The tool will only release once the crimp has been correctly formed.
- 19. Hold the crimping sleeve and gently pull the wire to make sure the crimping sleeve is secured.

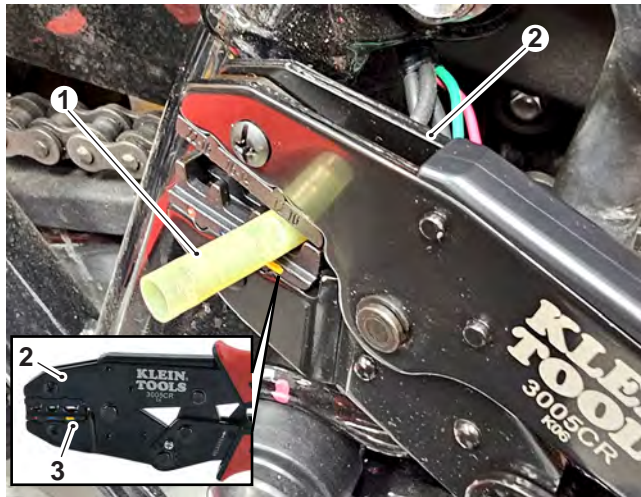

1. Crimping sleeve
2. Crimping tool T3880189
3. Yellow crimping feature

20. Repeat steps 14 to 19 for remaining two alternator wires of the alternator harness connector.

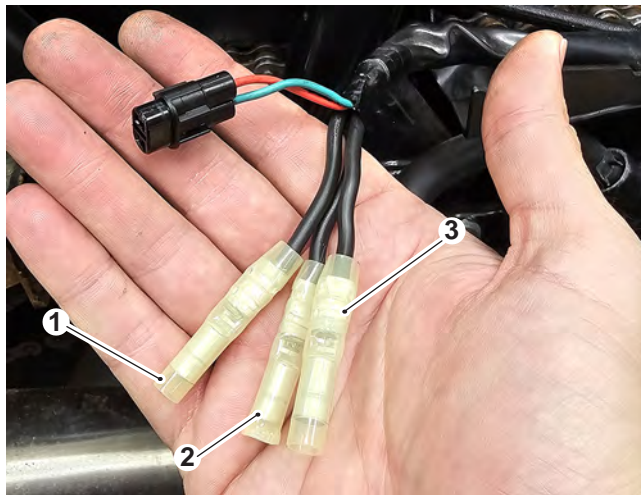

1. Alternator wire one
2. Alternator wire two
3. Alternator wire three

NOTICE

Inspect all crimping sleeves and make sure they are secured to the wires.

21. Slide the glue lined heat shrink sleeves over the crimping sleeve and position it over the newly crimped area and align it to the center stop.

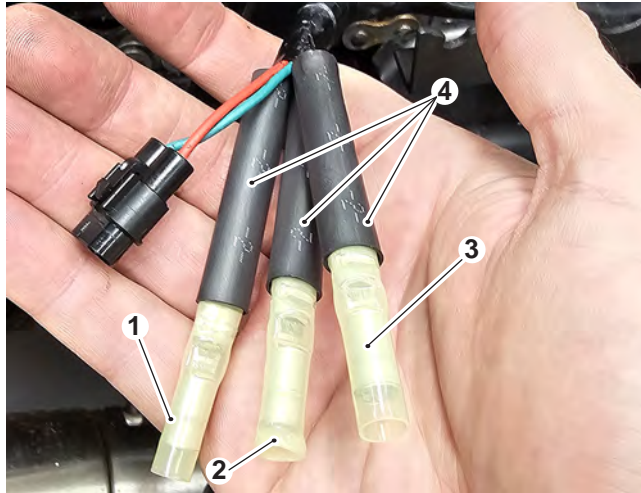

1. Alternator wire one
2. Alternator wire two
3. Alternator wire three
4. Glue lined heat shrink sleeves

⚠ CAUTION

Excessive heat can damage exposed wires, cables, mounting fixtures, brackets, electrical connectors and relays.

Always protect the surrounding area with suitable heat resistant material, such as a soldering mat before operating the heat gun.

Inspect the surrounding area afterward to confirm that no damage has occurred.

Failure to follow the advice above may lead to irreparable damage to the motorcycle.

NOTICE

Heat and shrink the glue lined heat shrink sleeve from the wire end first, then continue heating and shrinking it over the crimped area.

22. Position the crankshaft position sensor electrical connector away from the area to be heated.
23. Use a heat gun to shrink the glue lined heat shrink sleeve in place, making sure melted adhesive is visible at both ends.

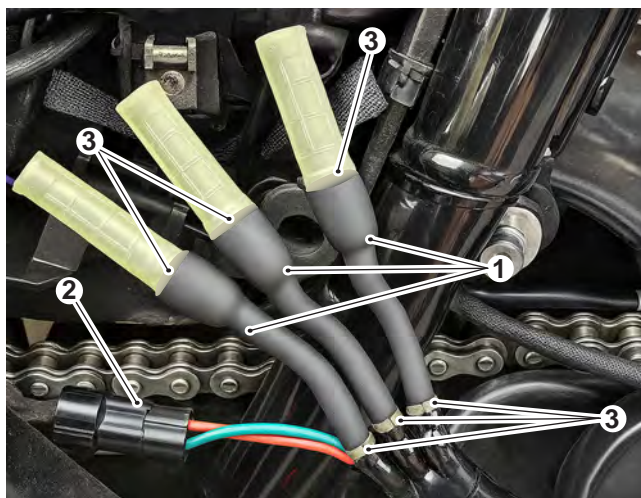

1. Glue lined heat shrink sleeves
2. Crankshaft position sensor electrical connector
3. Melted adhesive

24. Route the crimped alternator harness connector wires to its original position as shown below.

25. Connect the crankshaft position sensor electrical connector to the main harness connector.
26. Attach the crankshaft position sensor electrical connector to its locating feature.

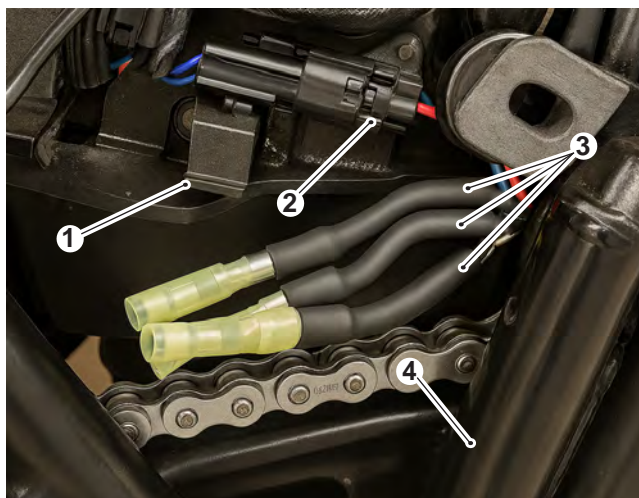

1. Mounting bracket
2. Crankshaft position sensor electrical connector
3. Crimped alternator harness connector wires
4. Frame

NOTICE

Make sure the wires are not damaged when trimming the PVC tube covering the main harness connector.

27. Using a suitable tool, trim the PVC tube covering to the tape as shown below.

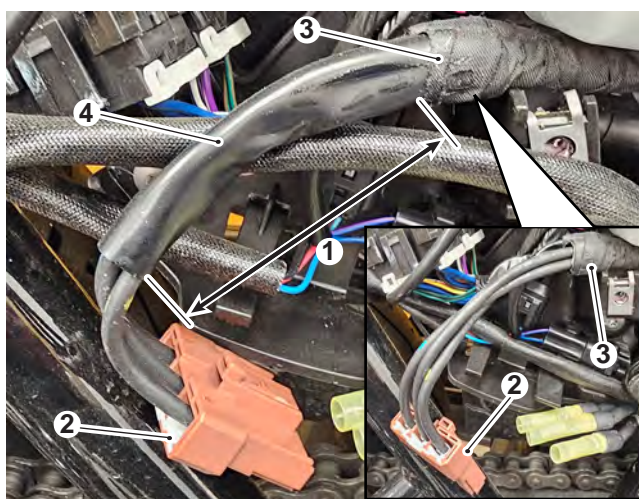

1. PVC tube covering
2. Main harness connector
3. Tape
4. PVC tubing

28. Cut the three wires of the main harness connector individually, make sure the cut is made as close to the rear of the connector as shown.

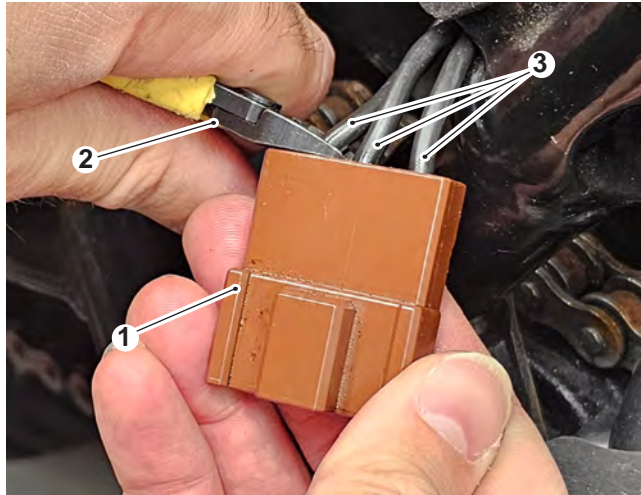

1. Main harness connector
2. Wire snips
3. Main harness wires

NOTICE

Only use wire stripper T3880188 for stripping the wire. Do not use any other wire stripper.
Make sure only 20 mm of insulation is removed from the wire.

29. Use the test wire from the kit and adjust the wire stripper using the rotating knob to match the correct size for the main harness wire.
30. Strip 20 mm of insulation from the test wire to make sure the wire strands are not cut while stripping off the insulation.
31. Strip 20 mm of insulation from the end of three main harness wires using wire stripper T3880188 and twist the wire ends as shown.
32. Wipe and clean the exposed wire strands and the outer surface of the remaining insulation to remove any oil or residue.

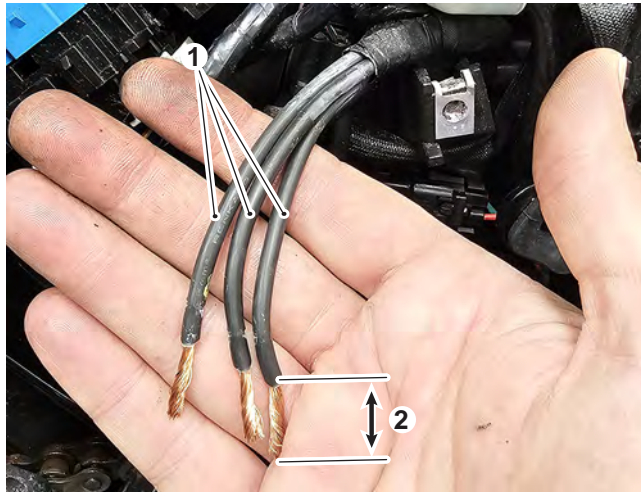

1. Main harness wires
2. 20 mm

33. Slide the glue lined heat shrink sleeves over the wires.



1. Glue lined heat shrink sleeves

NOTICE

Make sure the wire strands are not bent, cut, or damaged when inserting them into the crimping sleeve.

NOTICE

For optimal harness routing and alignment, make sure the wires are connected in a way that avoids crossing wires and allows each wire to sit naturally without stress, next to each other.

- 34. Insert one trimmed main harness wire into the other end of crimped alternator wire.
- 35. Align the main harness wire to the center stop.



- 1. Main harness wire**
- 2. Crimped alternator wire**
- 3. Center stop**

NOTICE

Use only crimping tool T3880189 for crimping. Do not use any other crimping tool.

- 36. Position the crimp sleeve within the yellow crimping feature of the crimping tool T3880189, make sure the terminal is centered in the crimping jaws.
- 37. Squeeze the crimping tool T3880189 handles until the tool releases. The tool will only release once the crimp has been correctly formed.
- 38. Hold the crimping sleeve and gently pull the wire to make sure the crimping sleeve is secured.
- 39. Repeat steps 34 to 38 for the other two wires of the main harness alternator connector.



1. Crimped alternator wires

NOTICE

Inspect all crimping sleeves and make sure they are secured to the wires.

40. Slide the glue lined heat shrink sleeves over the crimping sleeve and position it over the newly crimped area and align it to the center stop.



1. Glue lined heat shrink sleeve

⚠ CAUTION

Excessive heat can damage exposed wires, cables, mounting fixtures, brackets, electrical connectors and relays.

Always protect the surrounding area with suitable heat resistant material, such as a soldering mat before operating the heat gun.

Inspect the surrounding area afterward to confirm that no damage has occurred.

Failure to follow the advice above may lead to irreparable damage to the motorcycle.

NOTICE

Heat and shrink the glue lined heat shrink sleeve from the wire end first, then continue heating and shrinking it over the crimped area.

41. Position the crimped wires away from the motorcycle.

-
42. Use a heat gun to shrink the glue lined heat shrink sleeve in place, make sure melted adhesive is visible at both ends.

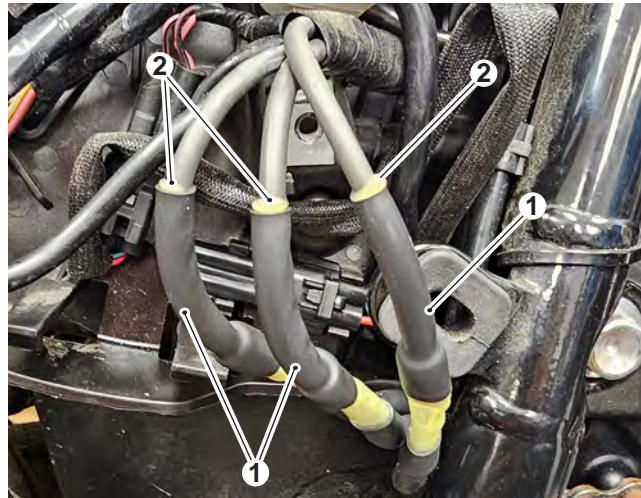

- 1. **Crimped alternator wires**
- 2. **Melted adhesive**

43. Position the crimped alternator wires under the front mounting bracket, make sure the wires are routed between the rear and the front mounting brackets as shown.

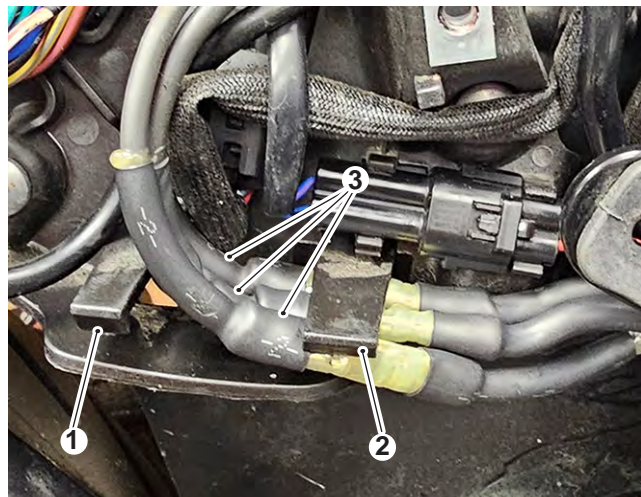

- 1. **Rear mounting bracket**
- 2. **Front mounting bracket**
- 3. **Crimped alternator wires**

44. Insert a cable tie through the mounting and secure the wires as shown.

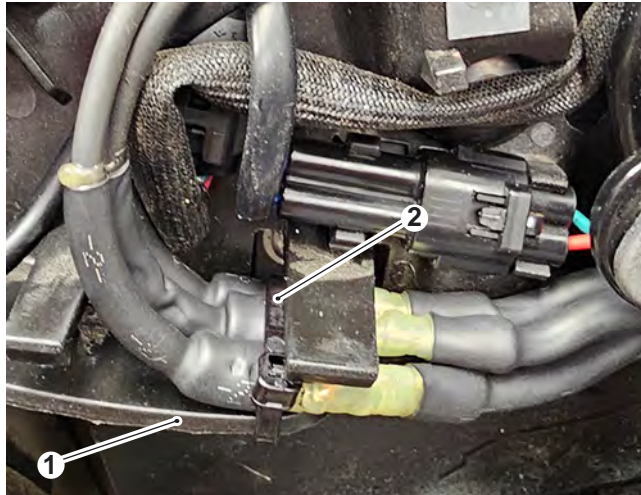

- 1. **Mounting**
- 2. **Cable tie**

- 45. Fit the rear brake fluid reservoir and install the new fixing from the kit. Tighten the new fixing to 3 Nm.
- 46. Check the brake fluid level in the rear brake fluid reservoir and refill if required.

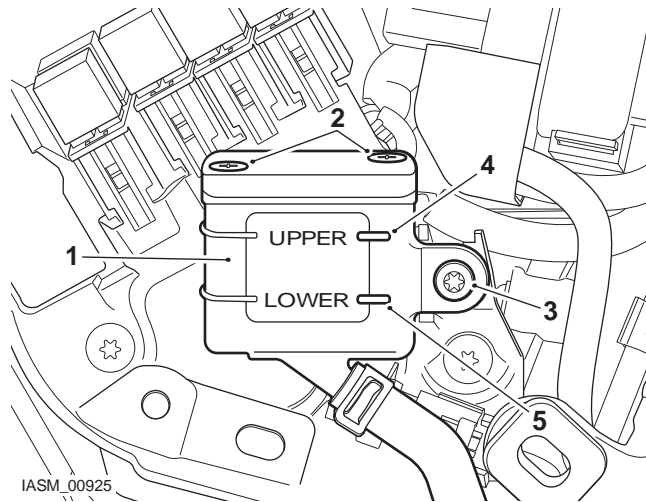

- 1. **Rear brake fluid reservoir**
- 2. **Cap fixings**
- 3. **Fixing**
- 4. **Upper level line**
- 5. **Lower level line**

- 47. Position the sprocket outer cover and install the fixings. Tighten the fixings to 9 Nm.

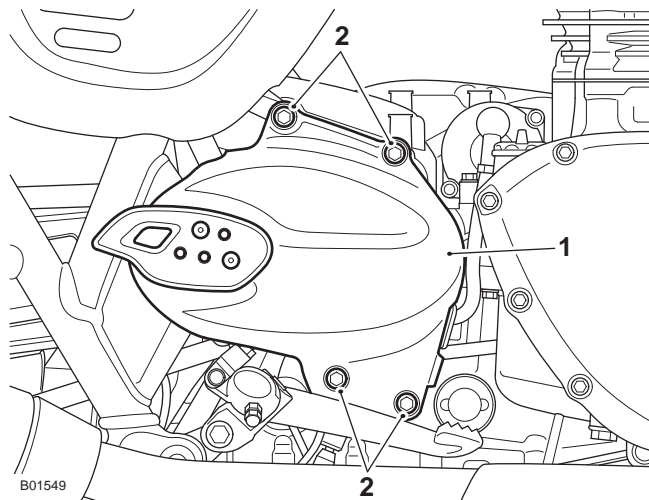

- 1. Sprocket outer cover
- 2. Fixings

48. Position the three locating dowels of right hand side panel to the grommets, then press firmly to secure the panel.

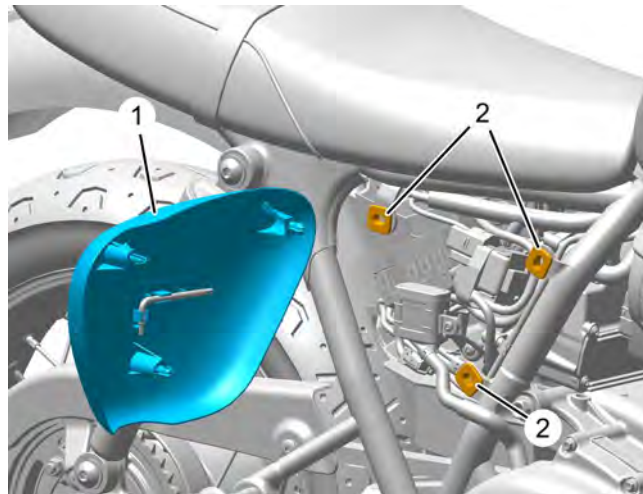

- 1. Right hand side panel
- 2. Grommets

49. Install the battery as described in the service manual.

NOTICE

As per bulletin 627, from VIN AB9715 to VIN AE2011 will continue to be fitted with an Alternator Connector Wire Clip.
 Vins after VIN BT0245 will continue to be fitted with an Alternator Connector Wire Alignment Clip.
 Do not remove the Alternator Connector Wire Alignment Clip from the above VINS.