

SAFETY RECALL

Volvo Trucks North America

Greensboro, NC USA

VOLVO

Release Date	Number	Release	Page
05.2026	RVXX2606	01	1(5)

Wheel Mounting Interference VAH, VHD, VN, VN (4)

RECALL INFORMATION

THIS IS A DO NOT DRIVE RECALL. ALL VEHICLES ARE RECOMMENDED TO STOP OPERATION UNTIL REPAIRED.

(May 2026)

Certain 2026-2027 model year VAH, VHD, VNL, VNM, VNR, VNR (4), and VNL (4) vehicles may have masking material from a painting process present between the wheels and axle hubs. This may cause the wheel lug nuts to loosen as the material compresses. A wheel and tire assembly that detaches from a vehicle while driving may lead to loss of vehicle control or create a hazard to other road users, increasing the risk of a crash or injury.

Volvo Trucks has not received any complaints or reports of vehicle crashes because of this safety defect; therefore, Volvo considers this as a proactive measure to protect the public and Volvo's customers from the potential risk associated with this defect.

To resolve this issue, follow the instructions provided below to inspect for paint masking ring(s) on all axles and remove the masking ring(s) as necessary. Replace any damaged parts.

VEHICLES AFFECTED

Certain 2026 through 2027 Volvo VAH, VHD, VNL, VNM, VNR, VNR (4), and VNL (4) models manufactured from June 16, 2025, through May 19, 2026.

VEHICLE QUANTITY

There are 194 vehicles affected by this recall (163 U.S. and 31 Canada).

Parts

Order parts through the normal process.

Part Number	Part Description	Quantity
Refer to Impact (VIN)	Steer/Drive Axle wheel studs	As needed
Refer to Impact (VIN)	Steer/Drive Axle Hub	If needed

Repair Instructions

1. Secure vehicle for service.
2. Install wheel chocks.

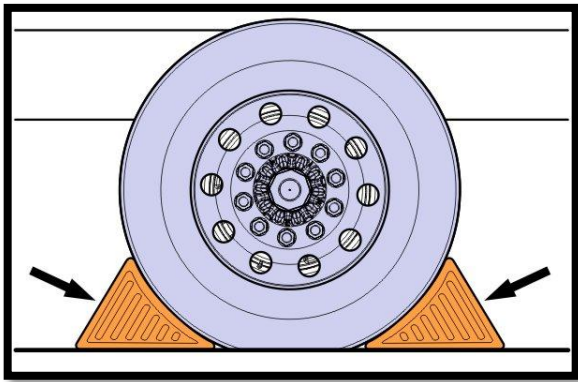

3. Raise wheel end.
4. Remove lug nuts and remove wheel.
5. Inspect for paint masking ring on all axles. Please note that masking ring may be painted with black axle paint as shown.



6. IF MASKING RING IS PRESENT:



- A. Remove all foreign material, if the vehicle has brake drums, remove drums and verify joints are free of debris.
- B. Inspect hub, studs, drums, and wheels for damage and replace if necessary.
- C. Reinstall wheel and secure lug nuts using standard tightening procedures.

Tightening Specifications
644±34 Nm (475±25 lb-ft)

7. IF MASKING RING IS NOT PRESENT:

- A. Reinstall wheel and secure lug nuts using standard tightening procedures.

Tightening Specifications
644±34 Nm (475±25 lb-ft)

8. Remove wheel chocks

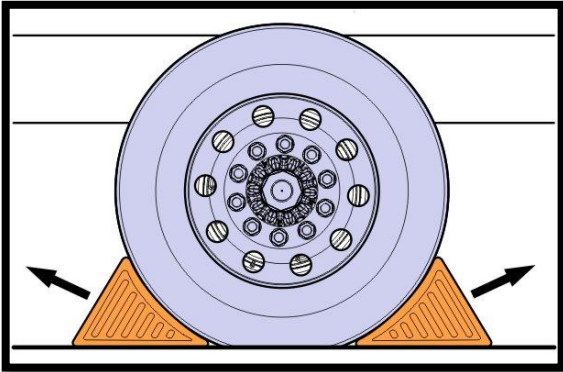

9. Release truck for service.

IMPORTANT NOTE:

Due to the nature of this Do Not Drive Recall, towing or technician travel may be considered on a case-by-case basis.

If contingent damage is found and/or towing, technician travel is needed, please reach out to campaign@volvo.com mailbox with supporting information.

REIMBURSEMENT

This repair is covered by an authorized Safety recall. Reimbursement is obtained through the normal claim handling process.	
	UCHP Reimbursement
Claim Type (used only when uploading from the Dealer Business System)	40
Recall Status	
Vehicle repaired per instructions	1-Modified per instructions
Labor Time Allowed Per Axle	
Per Steer Axle	0.7
Per Non – Steer Axle	1.3
Main Labor Code	Multiply to equal the amount determined above
1720-16-09-01 Campaign, General	0.1
Causal Part	21807998
Authorization Number	C0550

Note: Dealers or the designated representatives are required to perform Safety Recall on all subject vehicles at no charge to the vehicle owner regardless of mileage, age of vehicle or ownership (original purchaser or subsequent purchasers). Whenever vehicles that are subject to a Safety Recall are brought to your dealership for service, it is strongly recommended that every effort be made to perform the recall correction before the vehicle is released to the owner.