

5. Remove engine oil dipstick. See service manual.
 - a. Cover opening to prevent anything falling into oil pan.
6. Remove BCM caddy and BCM See service manual.
 - a. Cut and discard cable strap from caddy.
 - b. Move Wheel Speed Sensor (WSS) connector out of the way.
7. See Figure 1. Remove screws (2, 3) from frame crossmember (4).

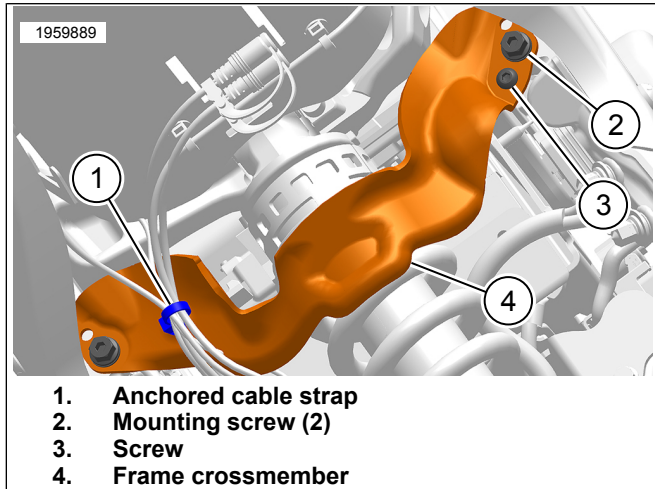

Figure 1. Frame Crossmember

8. See Figure 2. Remove scrivet (1) from rear lighting caddy.



Figure 2. Rear Lighting Caddy Scrivet

9. Move rear lighting caddy and frame crossmember out of the way toward the left side of the vehicle.
 - a. Take care as not to scratch vehicle frame or other painted components.
10. Remove mud guard. See service manual.
11. Remove Electronic Control Module (ECM). See service manual.
12. Remove ECM caddy. See service manual.

NOTE

See Figure 3. The right sub-frame (3) is displayed as transparent to better represent the brake line side plate bracket (2).

13. See Figure 3. Remove two screws (1) and brake line side plate bracket (2).

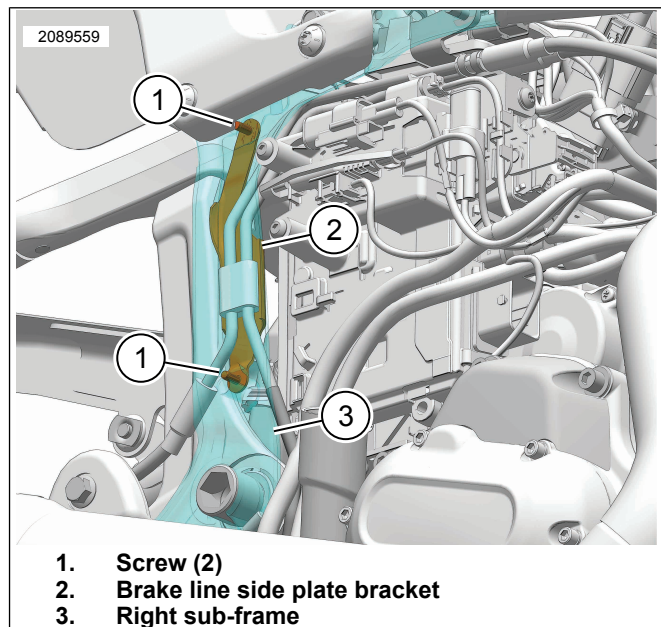
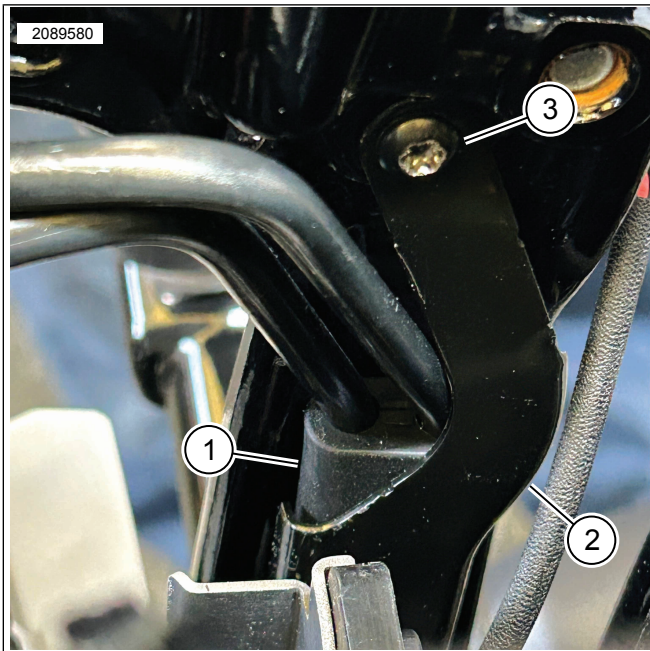

Figure 3. Right Brake Line Side Plate Bracket

14. Upon inspection and if non-cosmetic damage was found and a brake line replacement is needed, replace rear brake line connecting Anti-lock Braking System (ABS) module to rear master cylinder (Kit No. 91500127).
15. See Figure 4. Install second grommet to brake line.
 - a. Use alcohol and water 50/50 mix to ease installation.
 - b. Make sure split in grommet is facing the rear of vehicle.
 - c. Make sure it is pushed down and touching the existing grommet.
16. Install **new** brake line side plate bracket.
17. Install screws (3). Tighten.

Torque: 2.7–4.1 N·m (24–36 in-lbs)



1. Grommet
2. Brake line side plate bracket
3. Screw (2)

Figure 4. New Brake Line Side Plate Bracket

18. Remove battery strap. See service manual.
19. See Figure 5. Remove foam piece (2) from battery strap (1).
 - a. One foam piece (2) is removed.
 - b. Clean surface of battery strap from any residual glue.

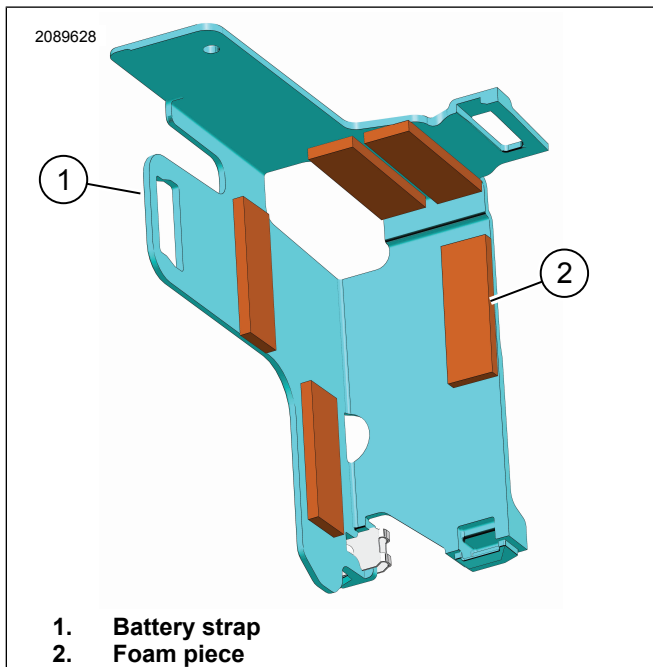

1. Battery strap
2. Foam piece

Figure 5.

20. See Figure 6. Remove and discard scrivet (2) that goes through battery tray (1) and purge caddy (3).

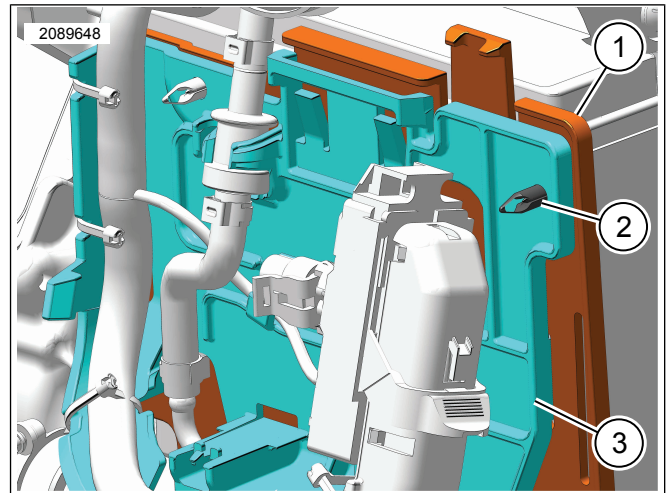

1. Battery tray
2. Scrivet
3. Purge caddy

Figure 6. Battery Tray Scrivet

21. See Figure 7. Install retaining clip.
 - a. Install threaded stud of retaining clip (1) into battery tray and exit through purge caddy.
 - b. Install nut (2). Tighten.
Torque: 6.2–7.3 N·m (55–65 in-lbs)

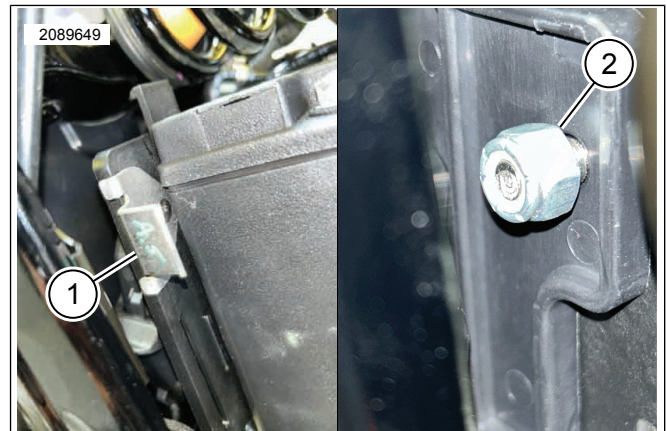

1. Retaining clip
2. Nut

Figure 7. Retaining Clip

22. Install battery strap. See service manual.
23. Install BCM to **new** BCM caddy. See service manual.
24. See Figure 8. Install **new** BCM caddy. See service manual.
 - a. Make sure gear position sensor is routed behind BCM.
 - b. Make sure tab on BCM caddy (1) is secured behind retaining clip (2).

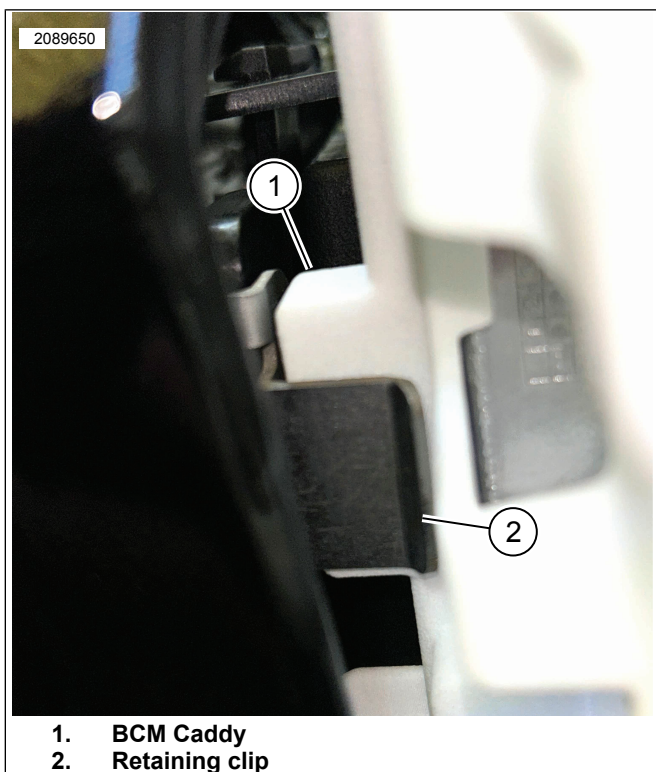

1. BCM Caddy
2. Retaining clip

Figure 8. BCM Caddy Secured

25. Install **new** cable strap to BCM caddy. See service manual.
 - a. Secure wire harnesses in cable strap. Do not tighten.
 - b. Remove excess slack in wire harnesses by pulling toward rear of vehicle.
 - c. Tighten cable strap.
26. Install all connectors to BCM caddy. See service manual.
 - a. Make sure for proper routing of Rear Wheel Speed Sensor (RWSS).
27. Install ECM caddy. See service manual.
28. Install ECM. See service manual.
29. Install mud guard. See service manual.
30. Move rear lighting caddy and frame crossmember back into vehicle.
31. See Figure 2. Install rear lighting caddy and scrivet (1).
32. See Figure 1. Install frame crossmember (4) and screws (2, 3). Tighten. See service manual.
33. Check for clearance between brake lines and **new** BCM caddy.
34. Install engine oil dipstick. See service manual.

35. Install close-out cover and right side cover. See service manual.
36. Install Maxi fuse. See service manual or owner's manual.
37. Install left side cover. See service manual.
38. Install seat. See service manual.
39. If Recall kit (Part No. 91500127) was used and brake line was replaced due to damage, complete ABS brake system bleed. See Service Manual.

Credit Procedure

NOTE

Enter bulletin number into comment section of claim.

For each vehicle involved in this recall (involvement of VIN has been verified on h-dnet.com), submit a recall claim per Table 4.

Table 4. Credit Procedure: Talon/h-dnet.com Warranty Claim System Users - REPLACEMENT OF BCM CADDY ONLY

ITEM	DATA
Claim Type	SRC
Problem Part Number	41800974
Quantity	Leave Blank
Primary Labor Code ⁽¹⁾	2732
Labor Time	0.9 hours
Customer Concern Code	0192
Condition Code	9981
Replacement Part Number	91500126
Quantity	1

(1) Download may be required

Table 5. Credit Procedure: GDP/SAP system users - REPLACEMENT OF BCM CADDY ONLY

ITEM	DATA
Claim Type	Recall Claim
Fix ID-Found in Recall Number	C
Problem Part Number	41800974
Customer Concern Code	0192
Condition Code	9981

Upon submission of the properly completed claim, you will be credited for 0.9 hours of labor time for performing the procedure, plus appropriate administrative time. Credit will also be issued for the recall kit (U.S. only). Submit campaign events on their own warranty claim. Do not mix them with other warranty events.

NOTE

The bulletin will be updated with the credit procedure for replacement of Kit No. 91500127.

Return Parts

Hold all claimed parts for 60 days from date of credit issued for possible field inspection and/or request to return to factory. After 60 days, destroy and discard the parts.