

Title:	Straight Axle Pitman Arm Torque			
Number:	Campaign 74B343	Release Date:	02/09/2026	
Revision Number:	Not Applicable	Revision Date:	Not Applicable	
Chassis Type:	Custom Chassis w/ Straight Axle			
Component Description:	Straight axle pitman arm			
Parts:	Sentry Seal (PN 95-1356)			
Tools:	Torque Wrench			

Procedure:

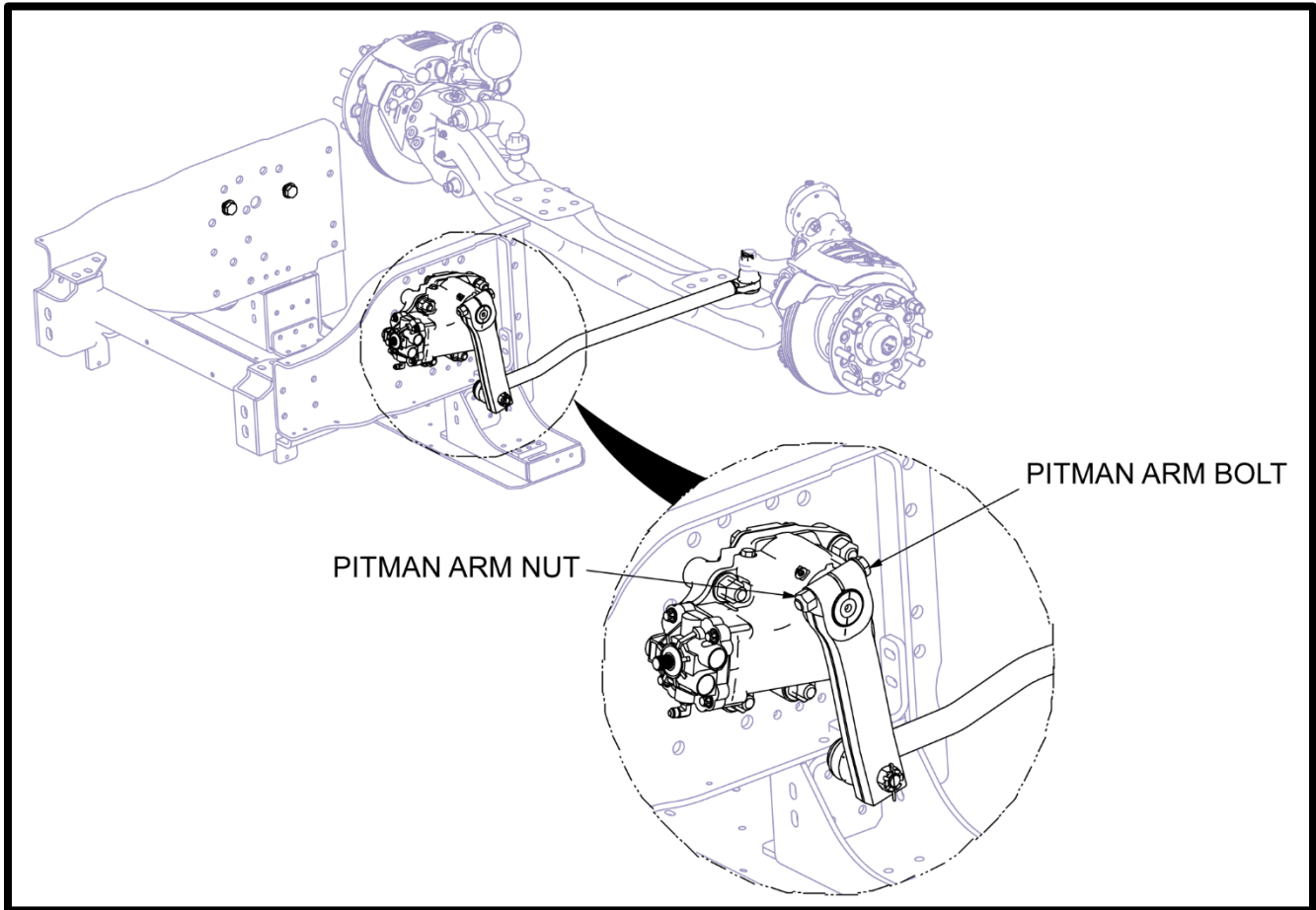

1. Check current torque of pitman arm bolt.
2. If torque of pitman arm bolt does not reach 257 lb-ft (348 N·m), tighten pitman arm bolt to 257 lb-ft (348 N·m).
3. Check current torque of pitman arm bolt and verify that it has reached 257 lb-ft (348 N·m).

⚠ WARNING

Adhesives, solvents, and sealing compounds can burn easily, can give off harmful vapors, and are harmful to skin and clothing. Keep away from open fire and use in well-ventilated area. If adhesives, solvents, or sealing compounds get on skin or clothing, wash immediately with soap and water. Failure to comply could result in serious injury or death to personnel.

4. Apply Sentry Seal (PN 95-1356) to pitman arm nut.

If any additional support is needed, please open a technical support incident on www.pierceparts.com.