



# Safety Recall

## Code: 93EW

### Subject High-Voltage (HV) Battery Modules

#### Document History

Date	Summary
04/07/2026	Labor operations have been updated.
03/17/2026	Original publication

#### Affected Vehicles

Country	Beginning Model Year	Ending Model Year	Vehicle	Vehicle Count
USA	2023	2024	ID.4	670
CAN	2023	2024	ID.4	136

Check Campaigns/Actions screen in ELSA on the day of repair to verify that a VIN qualifies for repair under this action. ELSA is the only valid campaign inquiry & verification source.

- ✓ Campaign status must show "open."
- ✓ If ELSA shows other open action(s), inform your customer so that the work can also be completed at the same time the vehicle is in the workshop for this campaign.

#### Problem Description

Individual battery cells in certain high-voltage (HV) battery cell modules manufactured during a certain production period may contain misaligned electrodes. In certain situations, a misaligned electrode in the HV battery cell may lead to a fire.

#### Corrective Action

Replace the potentially affected HV battery cell modules.

**IMPORTANT!** The battery cell module(s) that need to be replaced under this recall have been pre-identified by the factory for each affected vehicle. This recall work must be performed only by a certified Volkswagen battery repair dealer.

- U.S. owners can visit [vw.com](http://vw.com) and click on *Find a Dealer*, click on *Show Filter* and select the *EV Repair (including Battery)* filter to locate the closest certified Volkswagen battery repair dealer to have this recall work completed.
- Canada owners can visit [vw.ca](http://vw.ca) and click on *Find a Dealer* and select the *Filter by Service* and then select *EV High Voltage Battery Repair* to locate the closest certified Volkswagen battery repair dealer to have this recall work completed.

**IMPORTANT!** If the vehicle also has safety recall 93EA open, the 93EA software update and evaluation must be carried out before performing 93EW repairs.

#### Precautions:

Customers may experience a loss of range and/or performance if the recall condition exists in the vehicle. Customers with vehicle concerns are advised to have the vehicle diagnosed by an authorized Volkswagen dealer.

Until the remedy is performed, customers should:

- Set the vehicle's high-voltage battery system to an 80% state of charge limitation.
- Avoid using Level 3 DC chargers.
- Out of an abundance of caution, park the vehicle outdoors immediately after charging and do not leave the vehicle charging indoors overnight.

As a reminder, the vehicle owner's manual contains important information about vehicle charging. We encourage anyone who drives the vehicle to review the owner's manual to become familiar with this important information.

<b>Code Visibility</b>	On January 23, 2026, the campaign code was applied to the affected vehicles.
<b>Owner Notification</b>	Owner notification will take place in March 2026. Owner letter examples are included in this bulletin for your reference.
<b>Additional Information</b>	<p><b>Please alert everyone in your dealership about this action, including Sales, Service, Parts and Accounting personnel. Contact Warranty if you have any questions.</b></p> <p><b>IMPORTANT REMINDER ON VEHICLES AFFECTED BY SAFETY &amp; COMPLIANCE RECALLS</b></p> <p><b><u>USA Dealers - New Vehicles in Dealer Inventory:</u></b> It is a violation of federal law for a dealer to deliver a new motor vehicle or any new or used item of motor vehicle equipment (including a tire) covered by this notification under a sale or lease until the defect or noncompliance is remedied. By law, dealers must correct, prior to delivery for sale or lease, any vehicle that fails to comply with an applicable Federal Motor Vehicle Safety Standard or that contains a defect relating to motor vehicle safety.</p> <p><b><u>Canada Dealers – New Vehicles in Dealer Inventory:</u></b> Dealers must correct, prior to delivery for sale or lease, any vehicle that fails to comply with an applicable Canadian Motor Vehicle Safety Standard or that contains a defect relating to motor vehicle safety.</p> <p><b><u>All Dealers - Pre-Owned Vehicles in Dealer Inventory:</u></b> Dealers should not deliver any pre-owned vehicles in their inventory which are involved in a safety or compliance recall until the defect has been remedied.</p> <p>Dealers must ensure that every affected inventory vehicle has this campaign completed <u>before delivery to consumers.</u></p> <p>Fill out and affix Campaign Completion Label (CAMP 010 000) after work is complete. <i>Labels can be ordered at no cost via the Compliance Label Ordering portal at <a href="http://www.vwhub.com">www.vwhub.com</a>.</i></p>

## Parts Information

### NOTE

The criteria assigned to each VIN determines which cell module position must be replaced. Some vehicles will need more than one module replaced.

Criteria	Battery Type	Quantity	Part Number	P.O.C. Part Description	
ALL	82 kWh	As Needed	11K-915-599-D	CELL MOD.	
	62 kWh	As Needed	11K-915-592-D	CELL MOD.	
	ALL	<b>IMPORTANT INFORMATION FOR CELL MODULES:</b> 11K-915-599-D and 11K-915-592-D (Cell Module) will be return blocked. In the chance that a cell module needs returning, this return will need to be scheduled with your Dealer Support Specialist (DSS). For batteries not actively part of the repair process, either new or spent, dealers should ensure compliance with local fire code battery storage requirements. Dealers who have the appropriate storage capabilities/facilities that meet local fire code requirements, are encouraged to order/ stock parts to complete the 93EW Repair.			
		4 per cell module	N -912-809-01	SCREW	
		1 per cell module	D -G00-018-M3	PASTE	
		1 per cell module	0Z1-998-474	SEP. FILM	
		82 kWh	1	11A-998-844-B	Parts Kit* (see next page for kit contents)
	62 kWh	1	11A-998-844-C	Parts Kit* (see next page for kit contents)	
	ALL	1	D -454-300-A2	SEALANT	
		1	D -316-000-A1	UNDER COAT	
		Up to 2 L	G -12E-100-1G-CON	G12 EVO Coolant (US)	
			G -12E-100-2G-CON	G12 EVO Coolant (CAN)	
		The following underbody trim clips are needed ONLY in the event of breakage. They may not be required for every repair.			
	Up to 14	WHT-003-491	NUT		

#### Parts Control Type:

Reference POC comments individually by part number, or in the POC Campaign List

#### Initial Allocation:

**NO**

There will be no parts allocation.

**\*11A-998-844-B PARTS KIT CONTENTS  
(82 kWh battery)**

Quantity	Part Number	Part Description
1	1HV-915-754-A	VALVE
24	N -909-428-04	BOLT
4	N -912-832-01	BOLT
82	WHT-009-218	BOLT
22	WHT-008-738-A	BOLT
2	11K-802-131	CONNECTION
2	1EA-802-132-A	CONNECTION
1	1EA-998-103	SEP. FILM
4	N -102-252-02	BOLT

**\*11A-998-844-C PARTS KIT CONTENTS  
(62 kWh battery)**

Quantity	Part Number	Part Description
1	1HV-915-754-A	VALVE
22	N -909-428-04	BOLT
4	N -912-832-01	BOLT
72	WHT-009-218	BOLT
14	WHT-008-738-A	BOLT
2	11K-802-131	CONNECTION
2	1EA-802-132-A	CONNECTION
1	1EA-998-103	SEP. FILM
4	N -102-252-02	BOLT

**NOTE**

Your dealer's Estimated Remaining Repairs by campaign can be found in Parts on Command. Click on "View Campaign List" and review the Estimated Remaining Repairs column.

**NOTE**

Campaign parts should always be ordered as per the parts information in this circular. The ordering system will supersede the part, if applicable.

## Claim Entry Instructions

The labor times listed here may differ from the labor operations and labor times listed in ELSA.

After campaign has been completed, enter claim as soon as possible to help prevent work from being duplicated elsewhere. Attach the ELSA screen print showing action open on the day of repair to the repair order.

If a customer declines campaign work, refer to the "Customer Declines Campaign/Update Repair" section in the Campaign/Update Policy and Procedures Manual.

<b>Service Number</b>	93EW
<b>Damage Code</b>	0099
<b>Parts Vendor Code</b>	WWO
<b>Claim Type</b>	Sold vehicle: 7 10 Unsold vehicle: 7 90
<b>Causal Indicator</b>	Mark CELL MOD* as causal part
<b>Vehicle Wash/Loaner</b>	Do not claim wash/loaner under this action. Loaner/rental coverage cannot be claimed under this action. However, loaner/rental may be covered under the current loaner/mobility program. Please refer to the Volkswagen Warranty Policy and Procedures Manual for loaner claims information and reimbursement details.

**Vehicles may have more than one criteria.  
Complete and claim all applicable criteria on one claim.**

<b>Criteria I.D.</b>	ALL
----------------------	-----

### LABOR

Battery Type	Labor Op	Time Units	Description
82 kWh	93121982	SEE ELSA	Battery housing remove+reinstall
	93122982	SEE ELSA	Battery housing clean
	93031910	SEE ELSA	High voltage battery remove+reinstall
62 kWh	93121955	SEE ELSA	Battery housing remove+reinstall
	93122955	SEE ELSA	Battery housing clean
	93031950	SEE ELSA	High voltage battery remove+reinstall
ALL	19381750	SEE ELSA	Coolant drain+fill
ALL	93010050	SEE ELSA	Battery module (Package critical HV-ECM) (Claim for each module replaced)
ALL	93011950	SEE ELSA	Battery module remove+reinstall
ALL	93011953	SEE ELSA	Battery module remove+reinstall (Each additional part)
ALL	93018950	SEE ELSA	Battery module charge

Continued on next page

<b>LABOR (cont.)</b>			
<b>Battery Type</b>	<b>Labor Op</b>	<b>Time Units</b>	<b>Description</b>
ALL	93018953	SEE ELSA	Battery module charge (Each additional part)
ALL	93030150	SEE ELSA	High voltage battery check (pressure test after repairs)
ALL	93030153	SEE ELSA	High voltage battery check (Insulation measurement)
ALL	93108350	SEE ELSA	Disable HV system voltage deactivate and activate (Diagnostic activation HV System)
ALL	01500010	SEE ELSA	GFF/Guided functions (setup + battery charger)
ALL	01500060	Time stated on diagnostic protocol	GFF/Guided functions (GFF operations)
ALL	01210004	SEE ELSA	Test drive
<b>PARTS</b>			
<b>Battery Type</b>	<b>Quantity</b>	<b>Part Number</b>	<b>Description</b>
82 kWh	As required	11K915599D	CELL MOD.
	1.00	11A998844B	Parts Kit
62 kWh	As required	11K915592D	CELL MOD.
	1.00	11A998844C	Parts Kit
ALL	4.00 per cell module	N 91280901	SCREW
	1.00 per cell module	D G00018M3	PASTE
	1.00 per cell module	0Z1998474	SEP. FILM
	1.00	D 454300A2	SEALANT
	1.00	D 316000A1	UNDER COAT
	Up to 40.00	G 12E100S1	COOLANT CONCENTRATE

The following can be added if the HV battery cover required replacement

<b>PARTS</b>			
<b>Battery Type</b>	<b>Quantity</b>	<b>Part Number</b>	<b>Description</b>
82 kWh	1.00	11K804841E	HOUSING
62 kWh	1.00	11K804841D	HOUSING
ALL	8.00	11K804973	HOLDER
	1.00	1EA010505B	WARN. SIGN
	1.00	12E010006AA	STICKER

Continued on next page

The following can be added as needed in the event of breakage during the repair.

**PARTS**

<b>Battery Type</b>	<b>Quantity</b>	<b>Part Number</b>	<b>Description</b>
ALL	As required	WHT003491	NUT
	As required	WHT009733	BOLT
	As required	8E0825267	PUSH PIN
	As required	N 0385494	RIVET

## Customer Letter Example (USA)

<MONTH YEAR>

<CUSTOMER NAME>

<CUSTOMER ADDRESS>

<CUSTOMER CITY STATE ZIPCODE>

**This notice applies to your vehicle:** <MODEL YEAR> <BRAND> <CARLINE>, <VIN>

**NHTSA:** 26V028

**Subject: Safety Recall 93EW - High-Voltage (HV) Battery Modules**

Dear Volkswagen Owner,

This notice is sent to you in accordance with the National Traffic and Motor Vehicle Safety Act. Volkswagen has decided that a defect, which relates to motor vehicle safety, exists in certain 2023-2024 model year Volkswagen vehicles. Our records show that you are the owner of a vehicle affected by this action.

**What is the issue?**

Individual battery cells in certain high-voltage (HV) battery cell modules manufactured during a certain production period may contain misaligned electrodes. In certain situations, a misaligned electrode in the HV battery cell may lead to a fire.

**What will we do?**

To correct this defect, your authorized Volkswagen dealer will replace the potentially affected HV battery cell modules. This work will take up to one day to complete and will be performed for you free of charge. Please keep in mind that your dealer may need additional time for the preparation of the work, as well as to accommodate their daily workshop schedule.

**What should you do?**

Please contact your authorized Volkswagen dealer without delay to schedule this recall work.

Because the battery cell module(s) that need to be replaced under this recall have been pre-identified by the factory for each affected vehicle, this recall work must be performed only by a certified Volkswagen battery repair dealer.

Please visit [vw.com](http://vw.com) and click on *Find a Dealer*, click on *Show Filter* and then select the *EV Repair (including Battery)* filter to locate the closest certified Volkswagen battery repair dealer to have this recall work completed.

**Precautions you should take:**

Owners may experience a loss of range and/or performance if the recall condition exists in the vehicle. If you have any vehicle concerns, please make an appointment to have the vehicle diagnosed by an authorized Volkswagen dealer.

**Until the recall remedy is performed, owners should take the following precautions:**

- **Set the vehicle's high-voltage battery system to an 80% state of charge limitation.**
- **Avoid using Level 3 DC chargers.**
- **Out of an abundance of caution, park the vehicle outdoors immediately after charging and do not leave the vehicle charging indoors overnight.**

**As a reminder, the vehicle owner's manual contains important information about vehicle charging. We encourage anyone who drives the vehicle to review the owner's manual to become familiar with this important information.**

**Additional Information**

- If you are the lessor and registered owner of the vehicle identified in this action, the law requires you to forward this letter immediately via first-class mail to the lessee within ten (10) days of receipt.
- If your authorized Volkswagen dealer fails or is unable to complete this work free of charge within a reasonable time, if you have changed your address or no longer own the vehicle identified in this letter, or if you should have any questions about this communication, please reach out to us using your preferred method of communication at [www.vw.com/contact](http://www.vw.com/contact) or by calling us at 800-893-5298.
- If you still cannot obtain satisfaction, you may file a complaint with: The Administrator, National Highway Traffic Safety Administration, 1200 New Jersey Avenue, SE., Washington, DC 20590; or call the toll-free Vehicle Safety Hotline at 1-888-327-4236 (TTY:1-888-275-9171); or go to <http://www.safercar.gov>.
- To check your vehicle's eligibility for repair under this or any other recall/service campaign, please visit [www.vw.com/owners/recalls](http://www.vw.com/owners/recalls) and enter your Vehicle Identification Number (VIN) into the Recall/Service Campaign Lookup tool.

We apologize for any inconvenience this matter may cause; however, we are taking this action to help ensure your safety and continued satisfaction with your vehicle.

Sincerely,

Volkswagen Customer Protection

## Customer Letter Example (Canada)

<MONTH YEAR>

<CUSTOMER NAME>

<CUSTOMER ADDRESS>

<CUSTOMER CITY STATE ZIPCODE>

**This notice applies to your vehicle:** <MODEL YEAR> <BRAND> <CARLINE>, <VIN>

**Transport Canada Recall:** 2026-018

**Subject: Safety Recall 93EW – High-Voltage (HV) Battery Modules**

Dear Volkswagen Owner,

This notice is sent to you in accordance with the requirements of the *Motor Vehicle Safety Act*. This is to inform you that your vehicle may contain a defect that could affect the safety of a person. Our records show that you are the owner of a vehicle affected by this action.

**What is the issue?**

Individual battery cells in certain high-voltage (HV) battery cell modules manufactured during a certain production period may contain misaligned electrodes. In certain situations, a misaligned electrode in the HV battery cell may lead to a fire.

**What will we do?**

To correct this defect, your authorized Volkswagen dealer will replace the potentially affected HV battery cell modules. This work will take up to one day to complete and will be performed for you free of charge. Please keep in mind that your dealer may need additional time for the preparation of the work, as well as to accommodate their daily workshop schedule.

**What should you do?**

Please contact your authorized Volkswagen dealer without delay to schedule this recall work.

Because the battery cell module(s) that need to be replaced under this recall have been pre-identified by the factory for each affected vehicle, this recall work must be performed only by a certified Volkswagen battery repair dealer.

Please visit [vw.ca](http://vw.ca) and click on *Find a Dealer* and select the *Filter by Service* and then select *EV High Voltage Battery Repair* to locate the closest certified Volkswagen battery repair dealer to have this recall work completed.

**Precautions you should take:**

Owners may experience a loss of range and/or performance if the recall condition exists in the vehicle. If you have any vehicle concerns, please make an appointment to have the vehicle diagnosed by an authorized Volkswagen dealer.

**Until the recall remedy is performed, owners should take the following precautions:**

- **Set the vehicle's high-voltage battery system to an 80% state of charge limitation.**
- **Avoid using Level 3 DC chargers.**
- **Out of an abundance of caution, park the vehicle outdoors immediately after charging and do not leave the vehicle charging indoors overnight.**

**As a reminder, the vehicle owner's manual contains important information about vehicle charging. We encourage anyone who drives the vehicle to review the owner's manual to become familiar with this important information.**

**Additional Information**

- If you are the lessor and registered owner of the vehicle identified in this letter, you shall forward this letter (and any subsequent notice, if applicable) to the lessee within ten (10) days of receipt.
- If your authorized Volkswagen dealer fails or is unable to complete this work free of charge within a reasonable time, if you have changed your address or no longer own the vehicle identified in this letter, or if you should have any questions about this communication, please contact Customer Relations, Monday through Friday from 8AM to 8PM EST by phone at 1-800-822-8987 or via our "Contact Us" page at [www.vw.ca](http://www.vw.ca).

We apologize for any inconvenience this matter may cause; however, we are taking this action to help ensure your safety and continued satisfaction with your vehicle.

Sincerely,

Volkswagen Customer Protection

## Safety Precautions When Working ON the High-voltage System

(additional information is also available in the ELSA Repair Manual)

### DANGER

#### **Extremely dangerous due to high voltage.**

- The high-voltage system is under heavy voltage. Severe bodily injury or death by electrocution or electric arcs is possible.
- When working on the high-voltage system the high-voltage system must be de-energized.
- When performing procedures that do not directly affect the high-voltage system, in some cases it is still necessary to de-energize the high-voltage system.
- Pay attention when the high-voltage system must be de-energized. Refer to the Repair Manual
- Have a High-Voltage Technician or a High-Voltage Expert de-energize the high-voltage system.

#### **The electric and magnetic fields are extremely dangerous.**

- There are electric and magnetic fields on the high-voltage system. Death or serious injury are possible due to malfunction of active implants (for example cardiac pacemakers, insulin pumps).
- Persons with active implants may not perform procedures on the high-voltage system.

### WARNING

#### **Risk of injury - motor may start unexpectedly**

It is difficult to determine whether the drive system of an electric vehicle or hybrid vehicle is active. Moving parts can trap or draw in parts of the body.

### CAUTION

#### **Risk of damage to high-voltage wiring**

- Incorrect handling may result in damage to the insulation of high-voltage wires or high-voltage connectors.
- Do not support yourself on high-voltage cables or connectors.
- Never prop tools against high-voltage wiring or high-voltage connectors.
- Never bend or kink high-voltage wiring.
- Observe the coding of the high-voltage connectors when joining them up.

## Safety Precautions When Working NEAR the High-voltage System

(additional information is also available in the ELSA Repair Manual)

### DANGER

#### **Extremely dangerous due to high voltage.**

- The voltage levels in the high-voltage system constitute a safety hazard. Danger of severe or fatal injuries from electric shock if high-voltage components or high-voltage wiring are damaged.
- Carry out a visual check of high-voltage components and high-voltage wiring.
- Never use cutting/forming tools or other sharp-edged implements.
- Never perform work using welding, brazing, thermal bonding or hot air in the area of high-voltage components and high-voltage cables.

**⚠ DANGER**

**High voltage increases the risk of fatal injury**

**Electrocution can cause severe bodily or fatal injury.**

- For the following procedures suitable personal protective equipment must be worn.
- For the following steps two correspondingly qualified technicians must be present for the supervision.
- If necessary, a second technician can help the high-voltage expert outside of the hazardous area within their qualification.
- The personal protective equipment (PPE) must be dry and undamaged.

**Repair Overview**



- Replace one or more pre-identified cell modules inside the HV battery.

**⚠ CRITICAL REPAIR STEP**

**STOP STOP! STOP**

Vehicles affected by the 93EW are known to need replacement of at least one cell module inside the HV battery. NON-Battery Repair dealers CANNOT perform ANY of the work described in this campaign.

**⚠ CRITICAL REPAIR STEP**











**STOP STOP! STOP**

If the vehicle also has Safety Recall 93EA open, the 93EA software update and evaluation must be carried out before performing 93EW repairs.

 **NOTE**

- These repair instructions may differ from the labor operations and labor times listed in ELSA.
- Damages resulting from improper repair or failure to follow these work instructions are the dealer's responsibility and are not eligible for reimbursement under this action.
- This procedure must be read in its entirety prior to performing the repair.
- Due to variations in vehicle equipment and options, the steps/illustrations in this work procedure may not identically match all affected vehicles.
- Diagnosis and repair of pre-existing conditions in the vehicle are not covered under this action.
- When working during extreme temperatures, it is recommended that the vehicle be allowed to acclimate inside the shop to avoid temperature-related component damage/breakage.

## Required Tools

	<p>Engine Support Set -10-222B-</p>		<p>Adapter -10-222A/14-</p>
	<p>Module Lifting Aid -T10619-</p>		<p>Lifting Tackle -3033-</p>
	<p>Shock-Proof Protection (30 Pcs) -T10608-</p>		<p>Shock-Proof Protection -T10628-</p>
	<p>Removal Wedge Set -VAS895015-</p>		<p>Engine Support - Bracket w/Spindle and hook -10-222A/10-</p>
	<p>High-voltage tool set -VAS6762A-</p>		<p>High Voltage Tool Set - VAS6883A-</p>
	<p>Engine/Gearbox Support Shackle (2 pc.) -10-222A/12-</p>		<p>Shop Crane -VAS6100- (or equivalent)</p>



Pipe Brush  
-VAS294029-  
(or equivalent)



Scissor Lift Table  
-VAS6131B-  
(or equivalent)



Engine Bung Set  
-VAS6122-  
(or equivalent)



Hose Clamps - Up To  
25mm  
-3094-  
(or equivalent)



Shop Crane - Drip Tray  
-VAS6208-  
(or equivalent)



High Voltage Diagnostics  
Box  
-VAS5581A-  
/11



Diagnostic Lead  
-VAS5581A/11-



Leak-tight Connector  
-T10607-



Pressure and Vacuum  
Pump  
-VAS671005-





Digital Pressure Sensor  
-VAG1397B-



Pressure Sensor  
-VAS611013-



Leak Tester - Test  
Connector Set  
-VAS6911/3B-

	<p>Cooling System Tester - Directional Valve -VAS691005/1-</p>		<p>Insulating Mat -VAS6762/44-</p>
	<p>Cooling System Service Machine -VAS531011-</p>		<p>Cooling System Tester - Directional Valve -VAS691005/5-</p>
	<p>Cooling System Tester -VAG1274B-</p>		<p>High Voltage Tool Set - Voltage Tester -VAS6762/45-</p>
	<p>Module Balancer -VAS6910-</p>		<p>MEB Modules Expansion Set -VAS6910/21-</p>
	<p>Padlock -T40262/1- (from Service Disconnect Lock -T40262-)</p>		<p>Test Adapter - Hybrid Module -VAS6558A-</p>
	<p>Vehicle Diagnosis System - Connection Lead -VAS5051/66-</p>		<p>Template -T10606-</p>

 <p>Double Cartridge Adhesive Gun -VAS5237-</p>	 <p>Female adapter for the -VAS5237- (based on shops preferred adapter style) (locally sourced)</p>
 <p>Double Suction Lifter -VAG1344-</p>	 <p>High Voltage Test Adapter (without AFeS) -VAS6558A/35-</p>
 <p>Extension Cables for High-Voltage Battery -VAS671007-</p>	 <p>Insulated Torx Wrench Set - 3/8 -VAS691003A-</p>
 <p>Removal Wedge -T40233- (or equivalent)</p>	 <p>Diagnostic Tester -VAS6150X/6160X-</p>
 <p>Battery Tester/Charger capable of minimum 70 Amp continuous supply</p>	

## Required Shop Materials



Cleaner D -009-401-04  
(shop supply)

-OR-

91% Isopropyl Alcohol  
(locally sourced)



Lint Free Towels  
(locally sourced)

***NOTE: Use only 91% Isopropyl alcohol as a cleaner (9% water). Do not use Isopropyl with any additional surfactants (cleaners) or additives (scents).***

## Repair Instruction

### Section A - Check for Previous Repair

#### TIP

If Campaign Completion label is present, no further work is required.

Applicable criteria ID(s)	Campaign/Action Status
01 	Open 

**EXAMPLE**

Campaign/Action	Start	Designation
	2015-11-10	W-SERV_ACT -
	2018-12-13	RECALL -
	2017-05-16	A-RECALL -

**EXAMPLE**

- Enter the VIN in Elsa and proceed to the “Campaign/Action” screen.

#### TIP

On the date of repair, print this screen and keep a copy with the repair order.

- Confirm the Campaign/Action is open <arrow 1>. If the status is closed, no further work is required.
- Note the Applicable Criteria ID <arrow 2> for use in determining the correct work to be done and corresponding parts associated.

#### **CRITICAL REPAIR STEP**



All campaigns/actions with a repair available must be performed in order of the Start date <arrow 3>. The oldest should be performed first (unless otherwise noted in the repair instructions).

Proceed to Section B

#### **CRITICAL REPAIR STEP**



If the vehicle also has Safety Recall 93EA open, the 93EA software update and evaluation must be carried out before performing 93EW repairs.

## Section B – Repair Procedure

### ! IMPORTANT

The cell module serial number listed indicates the module location. It is possible that this may not be the location of the module with the affected serial number. Go by the cell module serial number and not the module location number.

- The serial number of the pre-identified cell module(s) that require replacement can be obtained using a feature in Elsa2Go.
- Enter the affected VIN into Elsa2Go and navigate to the Campaigns/Actions section.
- In the “Action” column, click on the “93EW Serial #” link (see example below).

	 <b>A-RECALL</b> REPAIR NOT YET AVAILABLE High-Voltage (HV) Battery Modules	Code <b>93EV</b>	Start Date 2025-12-05	Repair Date	Criteria ID 06	Action <b>93EW Serial #</b>
---	---	---------------------	--------------------------	-------------	-------------------	--------------------------------

To determine which serial number(s) are affected by 93EV, please verify the VIN and select Submit.

CLOSE

- Verify the VIN is correct and select Submit.

To determine which serial number(s) are affected by 93EV, please verify the VIN and select Submit.

**Affected Serial Numbers**  
module\_06:GCB-USA15.08.22F3VHF356

CLOSE

- The serial numbers for the pre-identified cell module(s) that require replacement will be populated.
- Record the serial number(s) for the cell modules which require replacement.

### ! NOTE

If a pre-identified cell module(s) has been replaced on a previous service visit, that module does not require replacement.

# IMPORTANT!

When the ELSA repair manual is referenced, ensure that all steps listed in that section are followed. This includes selecting hyperlinks within the section if additional steps are required by the repair manual.

## CRITICAL REPAIR STEP

 **STOP!** 

Before balancing the new cell module, be sure that the vehicle is ready for the repair to be performed.

If possible, the high voltage battery should be de-energized right after recording the voltage reading to avoid possible voltage variations.

Charging the vehicle, driving the vehicle, leaving the ignition on, or running the HVAC can change the high voltage battery voltage.

After reading out the max cell module voltage from the MVBs, avoid moving the vehicle if possible. The vehicle must not be charged or have any electrical consumers used. If this step is not followed, there is a risk that the new cell module will not be balanced correctly resulting in possible faults and having to remove and re-balance the cell module again.

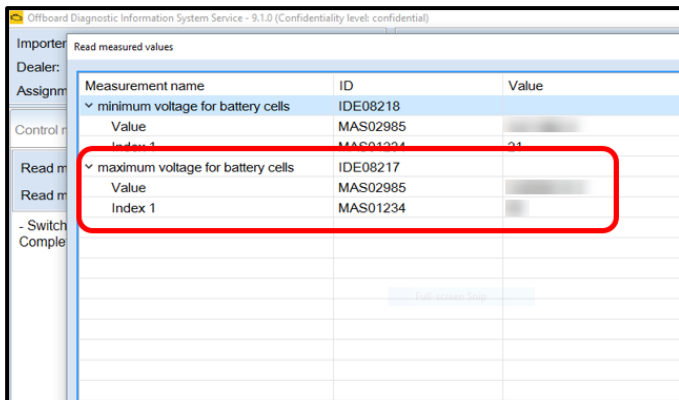

Measurement name	ID	Value
minimum voltage for battery cells	IDE08218	
Value	MAS02985	
Index 1	MAS01234	31
maximum voltage for battery cells	IDE08217	
Value	MAS02985	
Index 1	MAS01234	

### Perform cell balancing on new cell module:

- Check Measured Value Block (MVB) "maximum voltage for battery cells, IDE08217.
- The voltage reading listed will be entered in the DSS Manager program when balancing the new cell module.



- When charging or discharging a new cell module, follow the instructions in the ELSA repair manual in conjunction with the operating instructions for the cell balancer being used.

**TIP**

Operating instructions for the VAS6910, VAS6910A, and DSS Manager program can be found on the VW Special Tools and Equipment website.

Image shown may not be actual product. Product and price information are subject to change without notice.

Price: **\$12,984.18\***  
log in for dealer pricing.  
Available  
**Add To Cart**

**Notes**  
DSS Manager OperatingManual Rev02  
OperatingManual Rev10  
VAS 6910 Unpacking Instruction and Start-Up EN rev12

**De-energize the high-voltage system:**



**DANGER**

**High voltage increases the risk of fatal injury  
Electrocution can cause severe bodily or fatal injury**

Have a high-voltage technician or a high-voltage expert de-energize the high-voltage system.

- De-energize the high-voltage system per the ELSA repair manual:
  - *Repair manual > Motor > Electric Drive EQ310, EQ150, EQ550 > 93 Electric drive > De-Energized High-Voltage System.*

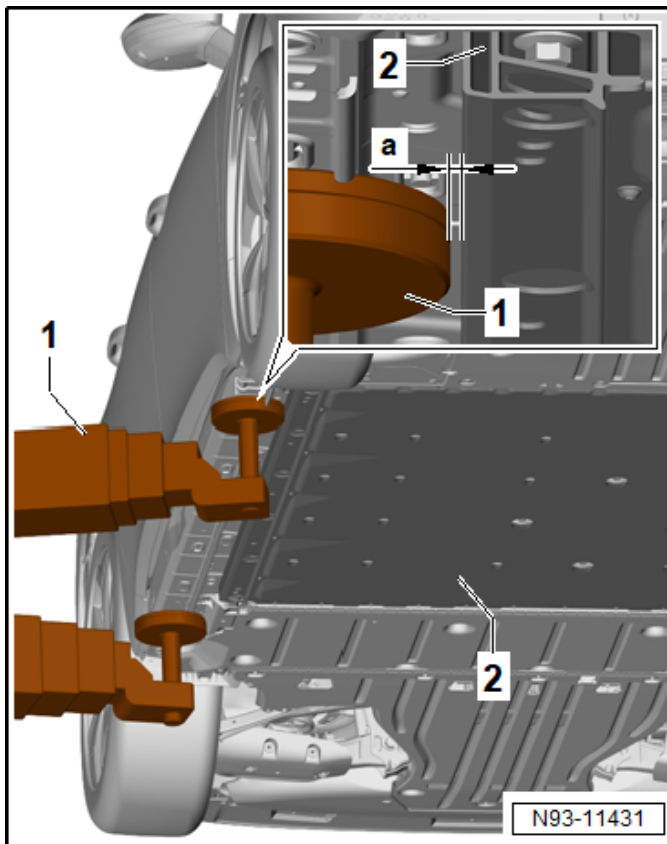

### Raise the vehicle:

#### **i** TIP

Removal of the high-voltage battery is not possible on all hoists. Make sure that there is enough clearance. Pay attention that the high-voltage battery has enough clearance <a> during the lifting process so that the Scissor Lift Table -VAS6131B- can be set down.

- Pivot in the hoist with the vehicle support plate <1> on the frame of the high-voltage battery <2>. Then pivot back the hoist arm with the vehicle support plate <1> <a> so that the high-voltage battery <2> can be lowered in the next steps.

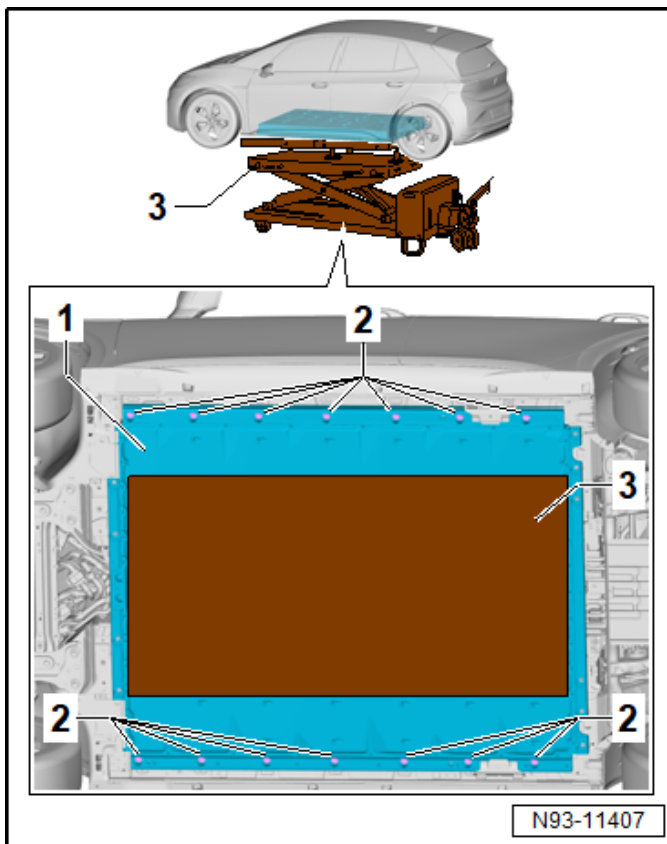

### Remove high-voltage battery:

- Remove the high-voltage battery from the vehicle per the ELSA repair manual:
  - **82 kWh battery:** *Repair manual > Motor > Electric Drive EQ310, EQ150, EQ550 > 93 Electric drive > High-Voltage Battery Unit, 82 kWh > High-Voltage Battery 1 AX2, Removing and Installing.*
  - **62 kWh battery:** *Repair manual > Motor > Electric Drive EQ310, EQ150, EQ550 > 93 Electric drive > High-Voltage Battery Unit, 62, 63 kWh > High-Voltage Battery 1 AX2, Removing and Installing.*
- Note the following when removing the high-voltage battery:
  - Mark the position of the scissor lift table on the floor to aid in re-positioning the table during reinstallation.
  - Pay close attention to all wiring harnesses when lowering the battery.
  - Pay close attention to coolant hoses when lowering the battery.

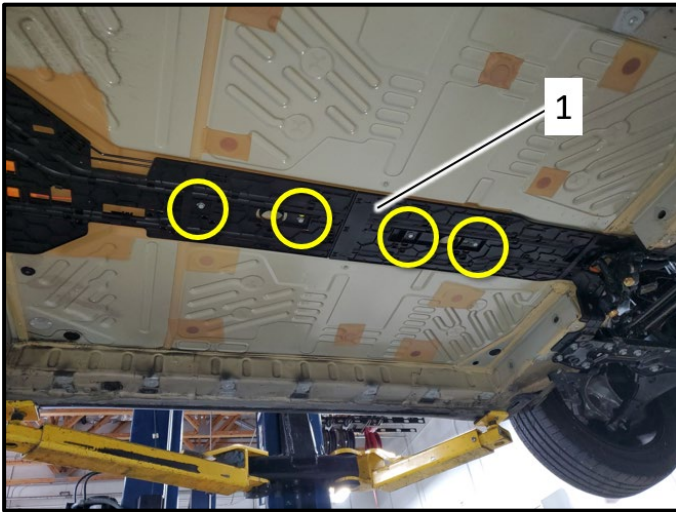

**Secure media duct/channel (if necessary):**

- If the media duct/channel <1> had not yet been secured, install new bolts <circles> and torque to 20 Nm.

**! NOTE**

If the media channel is already secured with bolts, the bolts do not have to be replaced again.

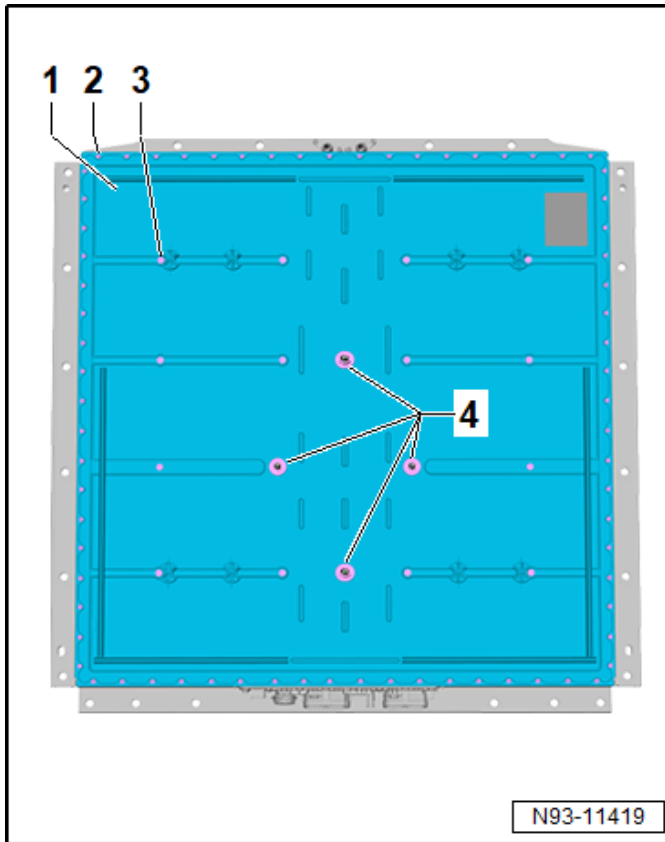

## Remove high-voltage battery cover:

### **⚠ CRITICAL REPAIR STEP**



#### **RISK OF SEVERE CONSEQUENTIAL DAMAGE! USE HAND TOOLS ONLY!**

Do not use power tools to remove any of the hollow bolts <4> or any of the perimeter bolts.

Using power tools to remove the bolts can damage the threads in the lower housing. Damaged threads for the hollow bolts <4> cannot be repaired and will require replacement of the lower housing.

Claims for lower housing replacements due to improper bolt removal will be denied.

- Open the high-voltage battery per the ELSA repair manual:
  - **82 kWh battery:** *Repair manual > Motor > Electric Drive EQ310, EQ150, EQ550 > 93 Electric drive > High-Voltage Battery Unit, 82 kWh > High-Voltage Battery 1 AX2, Opening.*
  - **62 kWh battery:** *Repair manual > Motor > Electric Drive EQ310, EQ150, EQ550 > 93 Electric drive > High-Voltage Battery Unit, 62, 63 kWh > High-Voltage Battery 1 AX2, Opening.*

### **⚠ DANGER**

#### **High voltage increases the risk of fatal injury Electrocution can cause severe bodily or fatal injury**

Pay close attention to which Repair Manual steps require Personal Protective Equipment.

### **ⓘ NOTE**

The upper part of battery housing can be reused under certain circumstances and does not have to be replaced.

To determine if the cover can be reused, refer to the ELSA Repair Manual:

**82 kWh battery:** *Repair Manual > Motor > Electric Drive EQ310, EQ150, EQ550 > 93 Electric drive > High-Voltage Battery Unit, 82 kWh > Battery Housing Upper Section, Checking for Re-Use.*

**62 kWh battery:** *Repair Manual > Motor > Electric Drive EQ310, EQ150, EQ550 > 93 Electric drive > High-Voltage Battery Unit, 62, 63 kWh > Battery Housing Upper Section, Checking for Re-Use.*



### Identify cell module which requires replacement:

- Identify the module that requires replacement and clearly mark its location.

#### NOTE

If the serial number cannot be found on any of the cell modules, it is possible the module was replaced on a previous service visit.

If the serial number cannot be found on any of the cell modules, create a VTA [WEB](#) ticket and wait for further instructions. Include photos of the serial numbers for each of the cell modules and the high-voltage battery identification/part number label.

Example of high-voltage battery identification, located on one end of the high-voltage battery case:

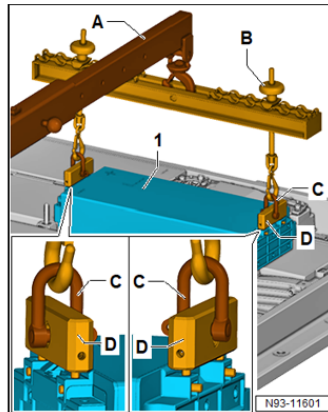
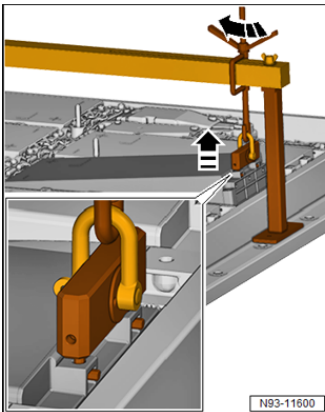
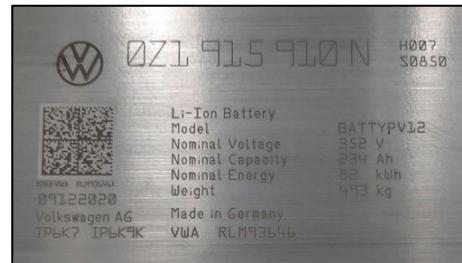

### Remove the cell module(s):

- Remove the affected cell module(s) per the ELSA repair manual:
  - **82 kWh battery:** *Repair Manual > Motor > Electric Drive EQ310, EQ150, EQ550 > 93 Electric drive > High-Voltage Battery Components, 82 kWh > Battery Module, Removing*
  - **62 kWh battery:** *Repair Manual > Motor > Electric Drive EQ310, EQ150, EQ550 > 93 Electric drive > High-Voltage Battery Components, 62, 63 kWh > Battery Module, Removing*
- Ensure the shock protection is installed on ALL open high-voltage connections.

#### TIP

Pay close attention to the wiring harnesses, so they are not damaged or pinched during removal.

The cell module can be freed from the adhesive bond from either end of the cell module.

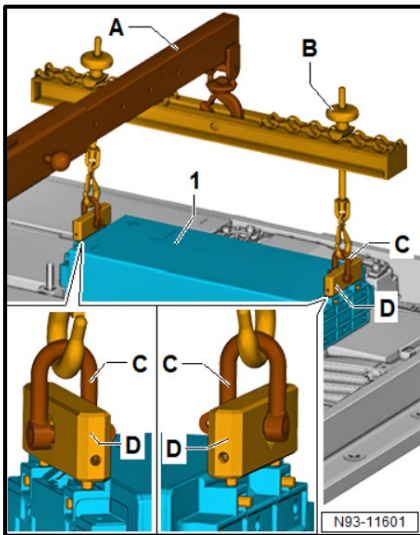

### Installing the new cell module(s):

- Install the new cell module(s) per the ELSA repair manual:
  - **82 kWh battery:** *Repair Manual > Motor > Electric Drive EQ310, EQ150, EQ550 > 93 Electric drive > High-Voltage Battery Components, 82 kWh > Battery Module, Installing.*
  - **62 kWh battery:** *Repair Manual > Motor > Electric Drive EQ310, EQ150, EQ550 > 93 Electric drive > High-Voltage Battery Components, 62, 63 kWh > Battery Module, Installing.*



- Double check the expiration date of the paste before applying.
- Use Double Cartridge Adhesive Gun -VAS5237- to apply the heat paste.
- Before applying the heat paste, release a small amount through the applicator to ensure the paste is mixing properly.

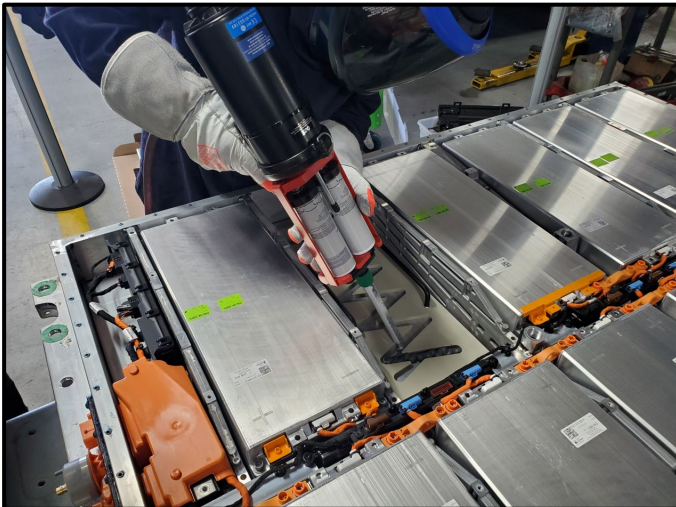

- When filling Template -T10606-, ALL of the heat paste must be used.



**⚠ DANGER**



**Incorrect installation of battery modules and module connectors.**

**Short circuit electric arc can cause severe bodily or fatal injuries.**

Check the battery modules and module connectors for correct installation.

Only continue with the procedure when there is no voltage in between the battery terminals.

Pay very close attention to the Repair Manual steps outlining the use of the -VAS6762/45-.

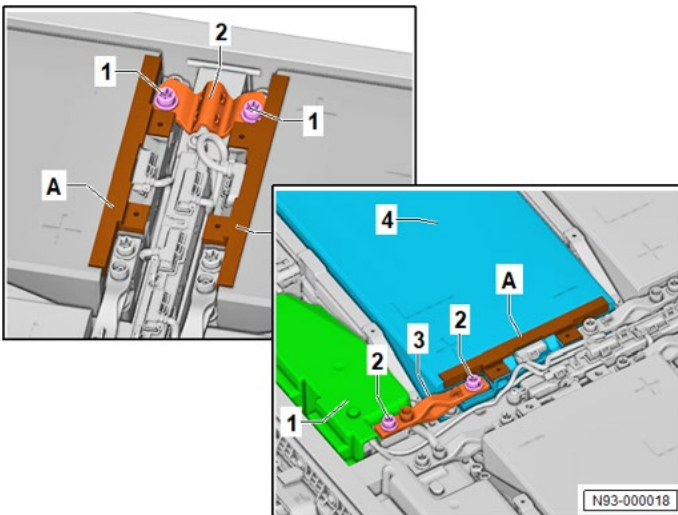

**Reconnect high-voltage circuit:**

- Reconnection is the reverse order of disconnecting.
- Reconnect the high-voltage circuit per the ELSA repair manual:
  - **82 kWh battery:** *Repair Manual > Motor > Electric Drive EQ310, EQ150, EQ550 > 93 Electric drive > High-Voltage Battery Unit, 82 kWh > Circuit, Disconnecting.*
  - **62 kWh battery:** *Repair Manual > Motor > Electric Drive EQ310, EQ150, EQ550 > 93 Electric drive > High-Voltage Battery Unit, 62, 63 kWh > Circuit, Disconnecting.*



**Check for high-voltage battery faults:**

- Using -VAS671007- or -VAS5581A-, in conjunction with the Diagnostic Tester, verify there are no faults stored for any high-voltage battery component before installing the high-voltage battery cover.

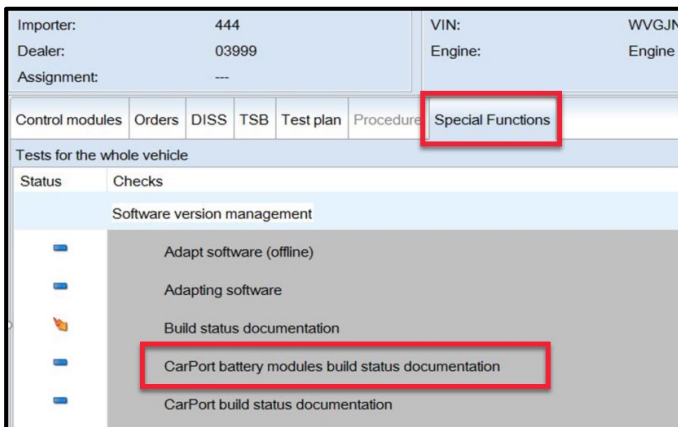

**Perform build status documentation test plan:**

- Before closing the battery, perform the “CarPort battery modules build status documentation” test plan.
  - *Special Functions > CarPort battery modules build status documentation.*

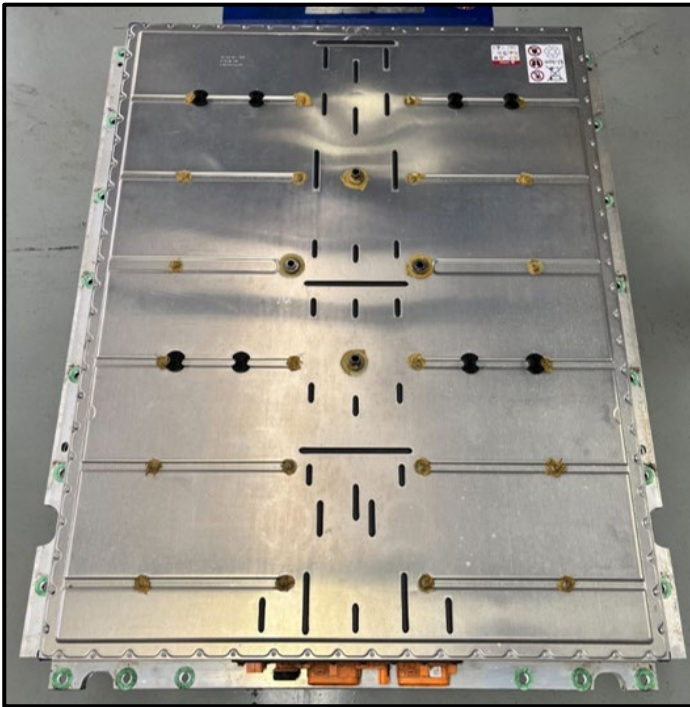

## Install and seal high-voltage battery cover:

### NOTE

The upper part of battery housing can be reused under certain circumstances and does not have to be replaced.

To determine if the cover can be reused, refer to the ELSA Repair Manual:

**82 kWh battery:** *Repair Manual > Motor > Electric Drive EQ310, EQ150, EQ550 > 93 Electric drive > High-Voltage Battery Unit, 82 kWh > Battery Housing Upper Section, Checking for Re-Use.*

**62 kWh battery:** *Repair Manual > Motor > Electric Drive EQ310, EQ150, EQ550 > 93 Electric drive > High-Voltage Battery Unit, 62, 63 kWh > Battery Housing Upper Section, Checking for Re-Use.*

### TIP

Ensure all shock protection is removed prior to installing cover.

Pay attention to the cover position. The cover part number stamping is positioned at the front of the high-voltage battery.

- Install and seal the battery cover per the ELSA repair manual:
  - **82 kWh battery:** *Repair Manual > Motor > Electric Drive EQ310, EQ150, EQ550 > 93 Electric drive > High-Voltage Battery Unit, 82 kWh > High-Voltage Battery 1 AX2, Sealing.*
  - **62 kWh battery:** *Repair Manual > Motor > Electric Drive EQ310, EQ150, EQ550 > 93 Electric drive > High-Voltage Battery Unit, 62, 63 kWh > High-Voltage Battery 1 AX2, Sealing.*

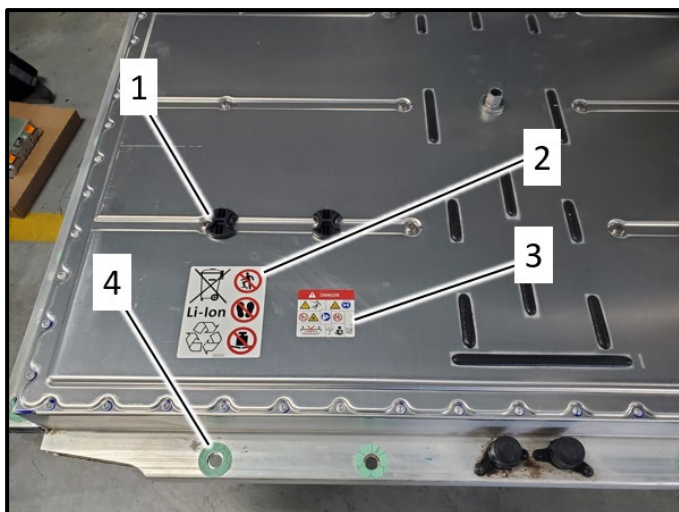

## Prepare high-voltage battery for installation:

### NOTE

Replacing the spacers and stickers is only necessary if the high-voltage battery cover is replaced.

- Install new spacers <1> (qty. 8) onto the high-voltage battery cover. Reference the old cover for installation position if needed.
- Apply new sticker <2> and warning sign <3>.
- Remove old separating film <4> from around the high-voltage battery mounting holes and install new separating film.
  - Do not install separating film if there was no existing film already in place.

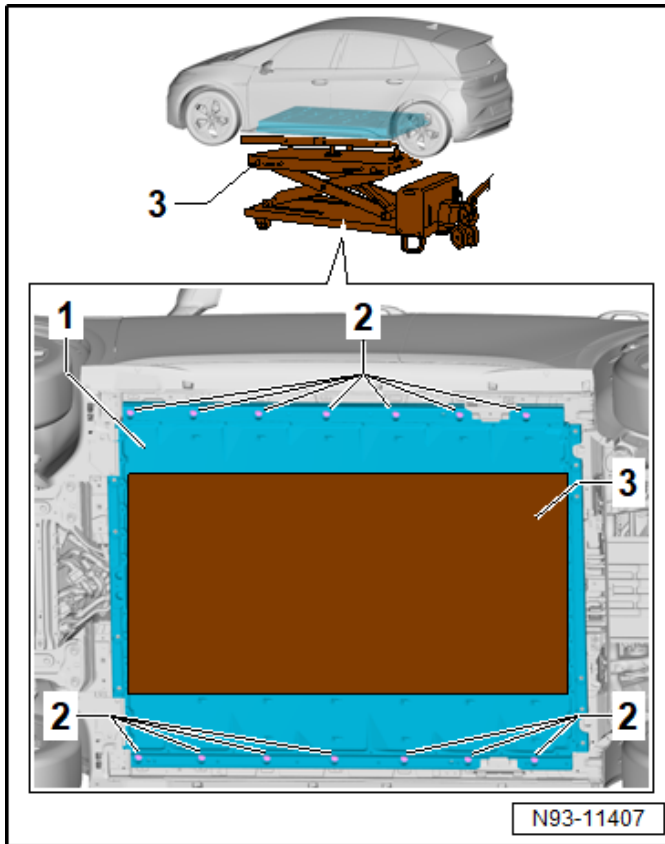

### Reinstall the high-voltage battery:

- Reinstall the high-voltage battery as per the ELSA repair manual:
  - **82 kWh battery:** *Repair manual > Motor > Electric Drive EQ310, EQ150, EQ550 > 93 Electric drive > High-Voltage Battery Unit, 82 kWh > High-Voltage Battery 1 AX2, Removing and Installing.*
  - **62 kWh battery:** *Repair manual > Motor > Electric Drive EQ310, EQ150, EQ550 > 93 Electric drive > High-Voltage Battery Unit, 62, 63 kWh > High-Voltage Battery 1 AX2, Removing and Installing.*

### Re-energize the high-voltage system:



#### **⚠ DANGER**

**High voltage increases the risk of fatal injury  
Electrocution can cause severe bodily or fatal injury**

Have a high-voltage technician or a high-voltage expert re-energize the high-voltage system.

- Re-energize the high-voltage system per the ELSA repair manual:
  - *Repair manual > Motor > Electric Drive EQ310, EQ150, EQ550 > 93 Electric drive > High-Voltage System, Re-Energizing.*

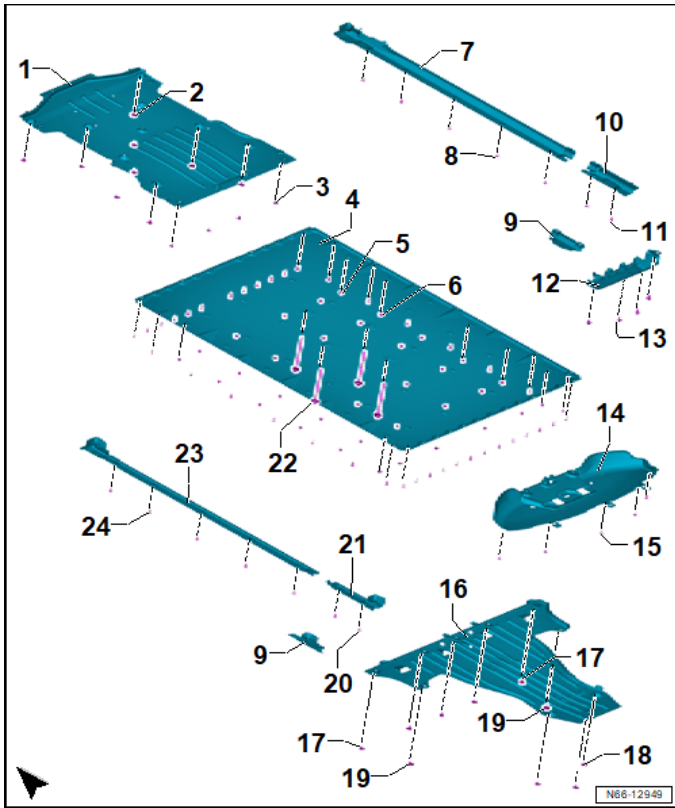

**Reinstall remaining components:**

- Installation is the reverse order of removal.
- Reference the ELSA Repair Manual as needed.
- Replace any damaged fasteners.

**Clear repair related faults:**

- Exit GFF and send the diagnostic protocol to GFF paperless.

**Proceed to Section C**

**NOTE**

All high-voltage cell modules that are replaced during this recall must be classified as DDR.

## Section C – Campaign Completion Label

### Install Campaign Completion Label

- Fill out and affix Campaign Completion Label, part number CAMP 010 000, next to the vehicle emission control information label.

 **TIP**

Ensure Campaign Completion Label does not cover any existing label(s).

**US DEALERS - Proceed to Section D**

**CANADIAN DEALERS - Proceed to Section E**

## **Section D - Parts Return/Disposal – US DEALERS ONLY**

### **High-Voltage Cell Modules:**

All high-voltage cell modules that are replaced during this recall must be classified as DDR.

The Volkswagen EHS Department recommends that DDR batteries be stored covered, outside, and at a minimum of 21 feet away from buildings and combustible materials. Dealers are responsible to contact the local AHJ (authority having jurisdiction) to ensure requirements to store DDR Batteries awaiting shipment are known.

Replaced High-Voltage Cell Modules or Batteries must be recycled through Redwood Materials.

The DDR crate will initially be shipped by your assigned PDC once inventory is available. Shipment of the crate will transition to Redwood after the initial campaign rollout.

Please request transportation and recycling services for proper disposal of HV modules by following the standard DDR process in the HV Battery Recycling Ordering Portal.

### **All other parts:**

Properly store (retain), destroy or dispose of removed parts in accordance with all state/province and local requirements, unless otherwise indicated and/or requested through the Warranty Parts Portal (WPP).

## **Section E - Parts Return/Disposal – CANADIAN DEALERS ONLY**

All high-voltage cell modules that are replaced during this recall must be classified as DDR.

Refer to the latest version of TSB 2060231

Properly store (retain), destroy or dispose of removed parts in accordance with all state/province and local requirements, unless otherwise indicated and/or requested through the Part Destruction and Core Disposition Report for Canada.