

F1029 A-O

Creation Date: May 2026

NHTSA #26V-079

Transport Canada #2026-054

Subject: Western Star Positive Junction Post

| Models Affected | | | | | |
|-----------------|-------|-----------------|---------------|------------------|-------------------|
| Make | Model | Model Yr. Start | Model Yr. End | Prod. Start Date | Prod. End Date |
| Western Star | 47X | 2021 | 2027 | July 8, 2020 | February 3, 2026 |
| Western Star | 49X | 2020 | 2027 | March 19, 2019 | February 10, 2026 |

General Information

On behalf of the entity listed below, Daimler Truck North America LLC (DTNA) has decided that a defect which relates to motor vehicle safety exists on the vehicles mentioned above.

- Wholly owned subsidiary Western Star Truck Sales, Inc.

PROBLEM: In the affected vehicles, the stud connecting the battery to the frame rail may fail due to incorrect installation or corrosion. If the stud fails, there is an increased risk of a short circuit and vehicle fire. Drivers may experience a slow or no crank when starting their vehicle.

SOLUTION: A Daimler Truck North America authorized service facility will remove the positive junction post and the jump start provision will be moved to an alternate location.

There are approximately 37,000 vehicles involved.

Additional Repairs

Dealers must complete all outstanding Recall and Field Service campaigns prior to the sale or delivery of a vehicle. A dealer will be liable for any progressive damage that results from its failure to complete campaigns before sale or delivery of a vehicle.

Owners may be liable for any progressive damage that results from failure to complete campaigns within a reasonable time after receiving notification.

Please contact Warranty Campaigns for consideration of additional charges prior to performing the repair.

Work Instructions

Please refer to the attached work instructions. Prior to performing the campaign, check the vehicle for a completion sticker (Form WAR260).

Replacement Parts

Replacement parts are now available and can be obtained by ordering the kit and/or part number(s) listed below from your facing Parts Distribution Center.

F1029 A-O

Creation Date: May 2026

NHTSA #26V-079

Transport Canada #2026-054

If our records show your dealership has ordered any vehicle(s) involved in campaign number F1029, a list of the customers and vehicle identification numbers will be available on DTNA Portal. Please refer to this list when ordering parts for this recall.

IMPORTANT – After Repair is Complete*:

After Repair is Complete*:

Attach a red completion sticker (WAR260) to the base label (WAR259).

If the vehicle does not have a base label, clean a spot on the appropriate location, and attach a base label, prior to attaching the completion sticker.

If a campaign kit is not required, write the campaign number on a blank sticker and attach it to the base label.

(Failure to install a completion sticker may result in a chargeback of the campaign claim.)

* TBB is exempt from the completion sticker process

| Group | Part Description | Part Number | Qty. |
|----------|--|----------------|------|
| A | CONDUIT-NYL,22MM,FLEX, | 48-25360-022 | 1 ft |
| A | CABLE-POS,4/0,SHORT 90,1/2X3/8,65 inch | A06-78035-065 | 1 ea |
| A | TUBE-HTS,DW,25.4MM(1.0),R | 66-47062-000 | 3 ea |
| A | STUD-THREADED TIE MOUNT,0.625 | 23-13805-062 | 1 ea |
| A | BATT TERM COPPER BUTT SPLICE-4/0 GA. | PHM 8 2980* | 1 ea |
| B, C, D, | CONDUIT-NYL,22MM,FLEX, | 48-25360-022 | 1 ft |
| B, C, D | CABLE-POS,4/0,SHORT 90,1/2X3/8,65 inch | A06-78035-065 | 1 ea |
| B, C, D | CABLE-JUMPER,POS,JUMP STUD | A66-12311-046 | 1 ea |
| B, C, D | TUBE-HTS,DW,25.4MM(1.0),R | 66-47062-000 | 4 ea |
| B, C, D | BRACKET-LONG 4 HOLE,ROUTING & CLPG | 12-25410-000 | 1 ea |
| B, C, D | TERMINAL-LUG,DEPOP,90,0.5,4/0,STUD | 23-13773-004 | 1 ea |
| B, C, D | SCREW, HEX FLNG,M8X1.25X30 | N910105 008016 | 1 ea |
| B, C, D | NUT-HEX,M8,DIN 934,A2, | 23-12612-008 | 1 ea |
| B, C, D | 13/32 X 13/16 L | 23-10900-038 | 1 ea |
| B, C, D | STUD-THREADED TIE MOUNT,0.625 | 23-13805-062 | 1 ea |

Table 1 Replacement Parts for F1029A-O

F1029 A-O

Creation Date: May 2026

NHTSA #26V-079

Transport Canada #2026-054

| Group | Part Description | Part Number | Qty. |
|--------------|--|--------------------|-------------|
| B, C, D | NUT-HEX,CROWN,WHT,NYL,M8X | 23-13379-001 | 1 ea |
| B, C, D | BATT TERM COPPER BUTT SPLICE-4/0 GA. | PHM 8 2980* | 1 ea |
| E | CONDUIT-NYL,22MM,FLEX, | 48-25360-022 | 1 ft |
| E | CABLE-POS,4/0,SHORT 90,1/2X3/8,65 inch | A06-78035-065 | 1 ea |
| E | CONDUIT-NYL,19MM,FLEX, | 48-25360-019 | 5 ft |
| E | ASSY,BATCBL,2/0,90BND1 | A06-35801-060 | 1 ea |
| E | TUBE-HTS,DW,25.4MM(1.0),R | 66-47062-000 | 3 ea |
| E | TUBE-HTS,DW,19.0MM(.75),R | 66-47062-001 | 3 ea |
| E | STUD-THREADED TIE MOUNT,0.625 | 23-13805-062 | 1 ea |
| E | BATT TERM COPPER BUTT SPLICE-4/0 GA. | PHM 8 2980* | 1 ea |
| E | BATT TERM COPPER BUTT SPLICE-2/0 GA. | PHM 8 2960** | 1 ea |
| F, G, H, O | CONDUIT-NYL,22MM,FLEX, | 48-25360-022 | 1 ft |
| F, G, H, O | CABLE-POS,4/0,SHORT 90,1/2X3/8,65 inch | A06-78035-065 | 1 ea |
| F, G, H, O | CABLE-JUMPER,POS,JUMP STUD | A66-12311-046 | 1 ea |
| F, G, H, O | CONDUIT-NYL,19MM,FLEX, | 48-25360-019 | 5 ft |
| F, G, H, O | ASSY,BATCBL,2/0,90BND1 | A06-35801-060 | 1 ea |
| F, G, H, O | TUBE-HTS,DW,25.4MM(1.0),R | 66-47062-000 | 4 ea |
| F, G, H, O | TUBE-HTS,DW,19.0MM(.75),R | 66-47062-001 | 3 ea |
| F, G, H, O | BRACKET-LONG 4 HOLE,ROUTING & CLPG | 12-25410-000 | 1 ea |
| F, G, H, O | TERMINAL-LUG,DEPOP,90,0.5,4/0,STUD | 23-13773-004 | 1 ea |
| F, G, H, O | SCREW, HEX FLNG,M8X1.25X30 | N910105 008016 | 1 ea |
| F, G, H, O | NUT-HEX,M8,DIN 934,A2, | 23-12612-008 | 1 ea |
| F, G, H, O | 13/32 X 13/16 L | 23-10900-038 | 1 ea |

Table 1 Replacement Parts for F1029A-O

F1029 A-O

Creation Date: May 2026

NHTSA #26V-079

Transport Canada #2026-054

| Group | Part Description | Part Number | Qty. |
|------------|--------------------------------------|----------------|------|
| F, G, H, O | NUT-HEX,JAM,1/2-13UNC | 23-09596-050 | 1 ea |
| F, G, H, O | WASHER-FLAT,SST,1/2in | 23-10900-050 | 1 ea |
| F, G, H, O | STUD-THREADED TIE MOUNT,0.625 | 23-13805-062 | 1 ea |
| F, G, H, O | NUT-HEX,CROWN,WHT,NYL,M8X | 23-13379-001 | 1 ea |
| F, G, H, O | BATT TERM COPPER BUTT SPLICE-4/0 GA. | PHM 8 2980* | 1 ea |
| F, G, H, O | BATT TERM COPPER BUTT SPLICE-2/0 GA. | PHM 8 2960** | 1 ea |
| I, J, K, L | CONDUIT-NYL,22MM,FLEX, | 48-25360-022 | 1ft |
| I, J, K, L | CABLE-JUMPER,POS,JUMP STUD | A66-12311-046 | 1 ea |
| I, J, K, L | CONDUIT-NYL,19MM,FLEX, | 48-25360-019 | 5 ft |
| I, J, K, L | ASSY,BATCBL,2/0,90BND1 | A06-35801-060 | 1 ea |
| I, J, K, L | TUBE-HTS,DW,19.0MM(.75),R | 66-47062-001 | 3 ea |
| I, J, K, L | BRACKET-LONG 4 HOLE,ROUTING & CLPG | 12-25410-000 | 1 ea |
| I, J, K, L | TERMINAL-LUG,DEPOP,90,0.5,4/0,STUD | 23-13773-004 | 1 ea |
| I, J, K, L | SCREW, HEX FLNG,M8X1.25X30 | N910105 008016 | 1 ea |
| I, J, K, L | NUT-HEX,M8,DIN 934,A2, | 23-12612-008 | 1 ea |
| I, J, K, L | 13/32 X 13/16 L | 23-10900-038 | 1 ea |
| I, J, K, L | NUT-HEX,JAM,1/2-13UNC | 23-09596-050 | 1 ea |
| I, J, K, L | WASHER-FLAT,SST,1/2in | 23-10900-050 | 1 ea |
| I, J, K, L | CLAMP-CABLE,BATT,DUAL,4/0,2/0 | 23-14775-002 | 2 ea |
| I, J, K, L | NUT-HEX,CROWN,WHT,NYL,M8X | 23-13379-001 | 1 ea |
| I, J, K, L | BATT TERM COPPER BUTT SPLICE-2/0 GA. | PHM 8 2960** | 1 ea |
| I, J, K | STUD-THREADED TIE MOUNT,0.625 | 23-13805-062 | 1 ea |
| M | CONDUIT-NYL,22MM,FLEX, | 48-25360-022 | 1 ft |

Table 1 Replacement Parts for F1029A-O

F1029 A-O

Creation Date: May 2026

NHTSA #26V-079

Transport Canada #2026-054

| Group | Part Description | Part Number | Qty. |
|-------|---|-------------------|------|
| M | CONDUIT-NYL,19MM,FLEX, | 48-25360-019 | 5 ft |
| M | ASSY,BATCBL,2/0,90BND1 | A06-35801-060 | 1 ea |
| M | BATT TERM COPPER BUTT SPLICE-2/0 GA. | PHM 8 2960** | 1 ea |
| M | TUBE-HTS,DW,19.0MM(.75),R | 66-47062-001 | 3 ea |
| M | STUD-THREADED TIE MOUNT,0.625 | 23-13805-062 | 1 ea |
| M | CLAMP-CABLE,BATT,DUAL,4/0,2/0 | 23-14775-002 | 2 ea |
| N | CONDUIT-NYL,22MM,FLEX, | 48-25360-022 | 1 ft |
| N | CABLE-POS,4/0,SHORT 90,1/2X3/8,65" | A06-78035-065 | 1 ea |
| N | CABLE-JUMPER,POS,JUMP STUD | A66-12311-046 | 1 ea |
| N | TERMINAL-LUG,DEPOP,90,0.5,4/0,STUD | 23-13773-004 | 1 ea |
| N | BATT TERM COPPER BUTT SPLICE-4/0 GA. | PHM 8 2980* | 1 ea |
| N | TUBE-HTS,DW,25.4MM(1.0),R | 66-47062-000 | 4 ea |
| N | BRKT-JUMPSTART,UHOOD | A66-21004-000 | 1 ea |
| N | NUT | DDE N910112008000 | 1 ea |
| N | CLAMP-CABLE,BATT,DUAL,4/0,2/0 | 23-14775-002 | 2 ea |
| N | SCREW-CAP,HEX,5/8-11 X 1.75,GRADE 8 | 23-09444-175 | 1 ea |
| N | NUT-HEX,5/8-11,GR8,ZINC AL | 23-13839-110 | 1 ea |
| N | WASHER-0.69X1.31X.177,YLW ZN,STEEL,HRDN | 23-09114-000 | 2 ea |
| N | BRACKET-LONG 4 HOLE,ROUTING & CLPG | 12-25410-000 | 1 ea |
| N | SCREW, HEX FLNG,M8X1.25X30 | N910105 008016 | 1 ea |
| N | 13/32 X 13/16 L | 23-10900-038 | 1 ea |
| N | NUT-HEX,M8,DIN 934,A2, | 23-12612-008 | 1 ea |
| N | NUT-HEX,CROWN,WHT,NYL,M8X | 23-13379-001 | 1 ea |
| N | STUD-THREADED TIE MOUNT,0.625 | 23-13805-062 | 1 ea |
| O | CONDUIT-NYL,22MM,FLEX, | 48-25360-022 | 1 ft |
| O | CABLE-POS,4/0,SHORT 90,1/2X3/8,65" | A06-78035-065 | 1 ea |
| O | BATT TERM COPPER BUTT SPLICE-4/0 GA. | PHM 8 2980* | 1 ea |

Table 1 Replacement Parts for F1029A-O

F1029 A-O

Creation Date: May 2026

NHTSA #26V-079

Transport Canada #2026-054

| Group | Part Description | Part Number | Qty. |
|------------|---|-------------------|-----------------|
| O | CABLE-JUMPER,POS,JUMP STUD | A66-12311-046 | 1 ea |
| O | TERMINAL-LUG,DEPOP,90,0.5,4/0,STUD | 23-13773-004 | 1 ea |
| O | NUT-HEX,JAM,1/2-13UNC | 23-09596-050 | 1 ea |
| O | WASHER-FLAT,SST,1/2in | 23-10900-050 | 1 ea |
| O | TUBE-HTS,DW,25.4MM(1.0),R | 66-47062-000 | 4 ea |
| O | CONDUIT-NYL,19MM,FLEX, | 48-25360-019 | 5 ft |
| O | ASSY,BATCBL,2/0,90BND1 | A06-35801-060 | 1 ea |
| O | BATT TERM COPPER BUTT SPLICE-2/0 GA. | PHM 8 2960** | 1 ea |
| O | TUBE-HTS,DW,19.0MM(.75),R | 66-47062-001 | 4 ea |
| O | BRACKET-LONG 4 HOLE,ROUTING & CLPG | 12-25410-000 | 1 ea |
| O | SCREW, HEX FLNG,M8X1.25X30 | N910105 008016 | 1 ea |
| O | 13/32 X 13/16 L | 23-10900-038 | 1 ea |
| O | NUT-HEX,M8,DIN 934,A2, | 23-12612-008 | 1 ea |
| O | NUT-HEX,CROWN,WHT,NYL,M8X | 23-13379-001 | 1 ea |
| O | STUD-THREADED TIE MOUNT,0.625 | 23-13805-062 | 1 ea |
| O | CLAMP-CABLE,BATT,DUAL,4/0,2/0 | 23-14775-002 | 2 ea |
| O | NUT | DDE N910112008000 | 1 ea |
| O | CLAMP-CABLE,BATT,DUAL,4/0,4/0 | 23-14775-001 | 2 ea |
| O | SCREW-CAP,HEX,5/8-11 X 1.75,GRADE 8 | 23-09444-175 | 1 ea |
| O | NUT-HEX,5/8-11,GR8,ZINC AL | 23-13839-110 | 1 ea |
| O | WASHER-0.69X1.31X.177,YLW ZN,STEEL,HRDN | 23-09114-000 | 2 ea |
| All Groups | NUT-HEX,LKG,ZNAL,M20X1.5 (used as tool) | 23-14451-120 | 1 ea per dealer |
| All Groups | WASHER-STL,HDND,ZNAL,BK,.750 (used as tool) | 23-14091-009 | 2 ea per dealer |
| All Groups | Blank completion sticker | WAR260 | 1 ea |

* Alternative part number available **66-47069-000**

** Alternative part number available **66-47069-001**

Table 1, Replacement Parts for F1029A-O

F1029 A-O

Creation Date: May 2026

NHTSA #26V-079

Transport Canada #2026-054

Removed Parts

- For U.S. and Canadian Dealers, use the part disposition in OWL to determine how to manage removed parts (return, scrap, etc.). Dispositions are available at the date of the repair.
- For Export Dealers, destroy removed parts unless otherwise advised.

U.S. and Canadian Dealers, please follow Warranty Failed Parts Tracking shipping instructions for the disposition of all removed parts. Export distributors, please destroy removed parts unless otherwise advised.

Claim Reimbursement — Labor Allowance

IMPORTANT: OWL must be viewed prior to performing the recall to ensure the vehicle is involved and the campaign has not been previously completed. Also, check for a completion sticker prior to beginning work.

You will be reimbursed for your parts, labor, and handling (landed cost for Export Distributors) by submitting your claim through the Warranty system within 30 days of completing this campaign.

- In OWL, use the 'Retrieve' function and select the appropriate procedure. This will auto-populate the PFP component code, replacement parts, cause, corrective action and SRT code in OWL.

| | |
|---------------------|-----------------|
| Claim Type | Recall Campaign |
| Campaign | F1029A-O |
| VMRS Component Code | F99-999-005 |
| Cause Code | A1 – Campaign |
| Primary Failed Part | 25-F1029-000 |

Table 2, Claim Reimbursement Table

| Groups | Procedure | Time Allowed (hours) | SRT Codes | Corrective Action |
|------------------------|-----------------------------------|----------------------|-----------|---------------------------|
| A, M | Replace one cable | 1.9 | 996-R267A | 12–Repair Recall/Campaign |
| B, C, D, I, J, K, L, N | Replace one cable and jump start | 2.2 | 996-R267B | 12–Repair Recall/Campaign |
| E | Replace two cables | 2.4 | 996–R267C | 12–Repair Recall/Campaign |
| F, G, H, O | Replace two cables and jump start | 2.7 | 996–R267D | 12–Repair Recall/Campaign |

Table 3, Labor Allowance for F1029A-O

F1029 A-O

Creation Date: May 2026

NHTSA #26V-079

Transport Canada #2026-054

- Claim type is **Recall Campaign**.
- In the Campaign field, enter the campaign number and appropriate group (F1029-A, F1029-B, etc.).
- In the Primary Failed Part field, enter 25-F1029-000.
- In the Parts section, enter the appropriate kit or part number(s) as shown in the Replacement Parts Table.
- In the Labor section, enter the appropriate SRT from the Labor Allowance Table. Administrative will auto-populate if applicable using SRT 939-6010A, for 0.3 hours.
- The VMRS Component Code is F99-999-005 and the Cause Code is A1 - Campaign.
- U.S. and Canada – Reimbursement for Prior Repairs. When a customer asks about reimbursement, please do the following:
 - Accept the documentation of the previous repair.
 - Make a brief check of the customer’s paperwork to see if the repair may be eligible for reimbursement. (See the ‘Copy of Owner Letter’ section of this bulletin for reimbursement guidelines.)
 - Submit an OWL Recall Pre-Approval Request for a decision.
 - Include the approved amount on your OWL claim in the Other Charges section.
 - Attach the documentation to the pre-approval request.
 - If approved, submit a ‘based on claim’ for the pre-approval.
 - The Dealer is required to reimburse the customer the appropriate amount.

IMPORTANT: OWL must be viewed prior to performing the recall to ensure the vehicle is involved and the campaign has not been previously completed. Also, check for a completion sticker prior to beginning work.

U.S. and Canadian dealers, contact the Warranty Campaigns Department via PNA at DTNAPortal.com, if you have any questions or need additional information. Export distributors, submit a Web inquiry or contact your International Service Manager.

U.S. and Canadian Dealers: To return excess kit inventory related to this campaign, U.S. dealers must submit a Parts Authorization Return (PAR) to the Memphis PDC. Canadian dealers must submit a PAR to their facing PDC. All kits must be in resalable condition. PAR requests must include the original purchase invoice number. Export Distributors: Excess inventory is not returnable.

The letter notifying U.S. and Canadian vehicle owners is included for your reference.

Please note that the National Traffic and Motor Vehicle Safety Act, as amended (Title 49, United States Code, Chapter 301), requires the owner’s vehicle(s) be corrected within a reasonable time after parts are available to you. The Act states that failure to repair a vehicle within 60 days after tender for repair shall be prima facie evidence of an unreasonable time. However, circumstances of a particular situation may reduce the 60-day period. Failure to repair a vehicle within a reasonable time can result in either the obligation to (a) replace the vehicle with an identical or reasonably equivalent vehicle, without charge, or (b) refund the purchase price in full, less a reasonable allowance for depreciation. The Act further prohibits dealers from selling a vehicle unless all outstanding recalls are performed. Any lessor is required to send a copy of the recall notification to the lessee within 10 days. Any subsequent stage manufacturer is required to forward this notice to its distributors and retail outlets within five working days.

F1029 A-O

Creation Date: May 2026

NHTSA #26V-079

Transport Canada #2026-054

Copy of Notice to Owners

Subject: Western Star Positive Junction Post

For Notice to U.S. Customers: This notice is sent to you in accordance with the requirements of the *National Traffic and Motor Vehicle Safety Act*. **For Notice to Canadian Customers:** This notice is sent to you in accordance with the requirements of the Motor Vehicle Safety Act.

Daimler Truck North America LLC (DTNA), on behalf of its wholly owned subsidiary, Western Star Truck Sales, Inc., has decided that a defect, that relates to motor vehicle safety, exists in certain model years 2020-2027 Western Star 47X, and 49X vehicles. See below for additional details: :

| Models Affected | | | | | |
|-----------------|-------|-----------------|---------------|------------------|-------------------|
| Make | Model | Model Yr. Start | Model Yr. End | Prod. Start Date | Prod. End Date |
| Western Star | 47X | 2021 | 2027 | July 8, 2020 | February 3, 2026 |
| Western Star | 49X | 2020 | 2027 | March 19, 2019 | February 10, 2026 |

On the affected vehicles, the stud connecting the battery to the frame rail may fail due to incorrect installation or corrosion. If the stud fails, there is an increased risk of a short circuit and vehicle fire. Drivers may experience a slow or no crank when starting their vehicle.

A Daimler Truck North America authorized service facility will remove the positive junction post and the jump start provision will be moved to an alternate location. The Recall will take approximately two hours and will be **performed free of charge**.

Please contact an authorized Daimler Truck North America dealer to arrange to have the Recall performed and to ensure that parts are available at the dealership. To locate an authorized dealer, search online at <https://northamerica.daimlertruck.com/contact-us>. Scroll down to "Locate a Dealer" and select the appropriate brand.

You may also confirm your vehicle's involvement in this recall at the following URL:

<https://dtna-dlrinfo.prd.freightliner.com:48518/VinLookup/vin-module/getVinLookupPage>

You may be liable for any progressive damage that results from your failure to complete the Recall within a reasonable time after receiving notification.

If you do not own the vehicle that corresponds to the identification number(s), which appears on the notification, please return the notification to the Warranty Campaigns Department with any information you can furnish that will assist us in locating the present owner. If you have leased this vehicle, Federal law requires that you forward this notice to the lessee within 10 days. If you are a subsequent stage manufacturer, Federal law requires that you forward this notice to your distributors and retail outlets within five working days. **For Notice to US Customers:** If you have paid to have this recall service condition corrected prior to this notice, you may be eligible to receive reimbursement. Please see the reverse side of this notice for details.

If you have questions about this Recall Campaign, please contact the Warranty Campaigns Department at (800) 547-0712, 7:00 a.m. to 4:00 p.m. Pacific Time, Monday through Friday, e-mail address DTNA-War-Campaigns@Daimler-truck.com. For other concerns, you may contact the Customer Assistance Center at (800) 385-4357. **For Notice to US Customers:** If your manufacturer, distributor, or dealer fails to remedy the defect or noncompliance without charge and

F1029 A-O

Creation Date: May 2026

NHTSA #26V-079

Transport Canada #2026-054

within a reasonable time, you may wish to submit a complaint to the Administrator, National Highway Traffic Safety Administration, 1200 New Jersey Avenue SE, Washington, DC 20590; or call the Vehicle Safety Hotline at (888) 327-4236 (TTY: 800-424-9153); or go to <http://www.nhtsa.gov>. **For Notice to Canadian Customers:** If you have a safety concern relating to this Recall, you may wish to contact Transport Canada – Motor Vehicle Safety at, 80 rue Noel, Gatineau, Quebec J8Z 0A1 or phone (800) 333-0510.

We regret any inconvenience this action may cause but feel certain you understand our interest in motor vehicle safety.

WARRANTY CAMPAIGNS DEPARTMENT

Enclosure

F1029 A-O

Creation Date: May 2026

NHTSA #26V-079

Transport Canada #2026-054

Reimbursement to Customers for Repairs Performed Prior to Recall

If you have already **paid** to have this recall condition corrected you may be eligible to receive reimbursement.

Requests for reimbursement may include parts and labor. Reimbursement may be limited to the amount the repair would have cost if completed by an authorized Daimler Truck North America LLC dealer. The following documentation must be presented to your dealer for consideration for reimbursement.

Please provide original or clear copies of all receipts, invoices, and repair orders that show:

- The name and address of the person who paid for the repair
- The Vehicle Identification Number (VIN) of the vehicle that was repaired
- What problem occurred, what repair was done, when the repair was done
- Who repaired the vehicle
- The total cost of the repair expense that is being claimed
- Proof of payment for the repair (such as the front and back of a cancelled check or a credit card receipt)

Reimbursement will be made by check from your Daimler Trucks North America LLC dealer.

Please speak with your Daimler Trucks North America LLC authorized dealer concerning this matter.

F1029 A-O
Creation Date: May 2026
NHTSA #26V-079
Transport Canada #2026-054

WORK INSTRUCTIONS

Subject: Western Star Positive Junction Post

| Models Affected | | | | | |
|-----------------|-------|-----------------|---------------|------------------|-------------------|
| Make | Model | Model Yr. Start | Model Yr. End | Prod. Start Date | Prod. End Date |
| Western Star | 47X | 2021 | 2027 | July 8, 2020 | February 3, 2026 |
| Western Star | 49X | 2020 | 2027 | March 19, 2019 | February 10, 2026 |

| Required Tools Table | | |
|---------------------------------|-------------|--|
| Part Number | Description | Image |
| Jonard CST-1900 (or equivalent) | Stripper |  <p>Fig 1, Jonard CST-1900</p> |

Table 4 Tool Table

F1029 A-O
Creation Date: May 2026
NHTSA #26V-079
Transport Canada #2026-054



| | | |
|--|----------------|--|
| <p>Milwaukee 48-22-4016 (or equivalent)</p> | <p>Cutter</p> |  <p>Fig 2, Milwaukee 48-22-4016</p> |
| <p>Burndy MRC840 (or equivalent)</p> <p>*Equivalent crimpers are designed for use with copper terminals and copper wire, designed for 2/0 and 4/0 wire, and provide a controlled crush in the crimp area, and no adjustable die.</p> | <p>Crimper</p> |  <p>Fig 3, Burndy MRC840</p> |

Table 4, Tool Table

F1029 A-O

Creation Date: May 2026

NHTSA #26V-079

Transport Canada #2026-054

Group A Work Instructions

1. Check the base label (Form WAR259) for a completion sticker for F1029 (Form WAR260), indicating this work has been done. The base label is usually located on the passenger-side door, about 12 inches (30 cm) below the door latch. If a completion sticker is present, no work is needed. If a completion sticker is not present, proceed to the next step.
2. Park the vehicle on a level surface and set the parking brake. Chock the rear tires.
3. Turn the steer wheels to the left side to make the isolated stud accessible. Shut down the engine.
4. Open the hood.
5. Locate the isolated positive (+) battery stud mounted on the frame behind the front wheel. See Fig. [Fig. 4](#).

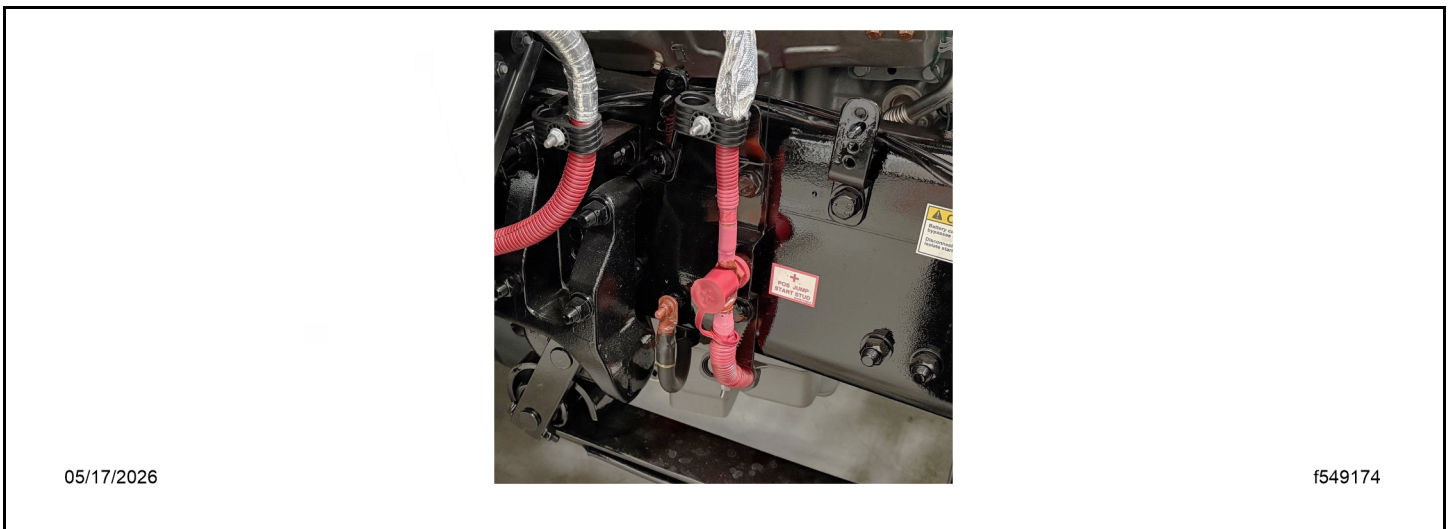

Fig 4, Isolated Battery Junction with Jump-Start Post

6. Remove the negative (-) cable connection(s) from the batteries.
7. If required for access, remove the splash shield from behind the front tire. For detailed instructions, see Group 88 of the *47X, 48X and 49X Workshop Manual*.
8. Remove the jump-start post or nut that secures the battery cable(s) to the isolated stud.
9. Remove the clamp(s) that secure the positive battery cables to the clipping point above the frame rail.
10. Remove the clamp(s) and ties that secure the positive battery cable routed between the isolated stud and the starter.
11. Remove the nut that secures the positive battery cables to the starter.
12. Remove the cable that connects the isolated stud to the starter.
13. Remove the bolts that secure the isolated stud bracket to the frame.
14. Remove the isolated stud from the frame bracket.
15. Install the upper isolator bracket frame bolt in position with the head on the inboard side of the frame.

F1029 A-O

Creation Date: May 2026

NHTSA #26V-079

Transport Canada #2026-054

16. Install the isolator bracket, washer, and nut. Hand-tighten the fasteners to keep the bracket in position.
17. Install the lower isolator bracket frame bolt with head on the outside of the frame. Tighten both fasteners to 148 lbf·ft (200 N·m).
18. If required, apply touch-up paint to the frame bolts.
19. Remove the ring terminal from the positive cable that is routed to the cab.
 - a. Note how the cable is secured and remove any cable ties, tape, or convolute as needed to uncover at least 6 inches of the cable.
 - b. Remove the original heat shrink. To do so, heat it, score it, and continue to heat it until the score splits and the adhesive softens. See Fig. [Fig. 5](#).

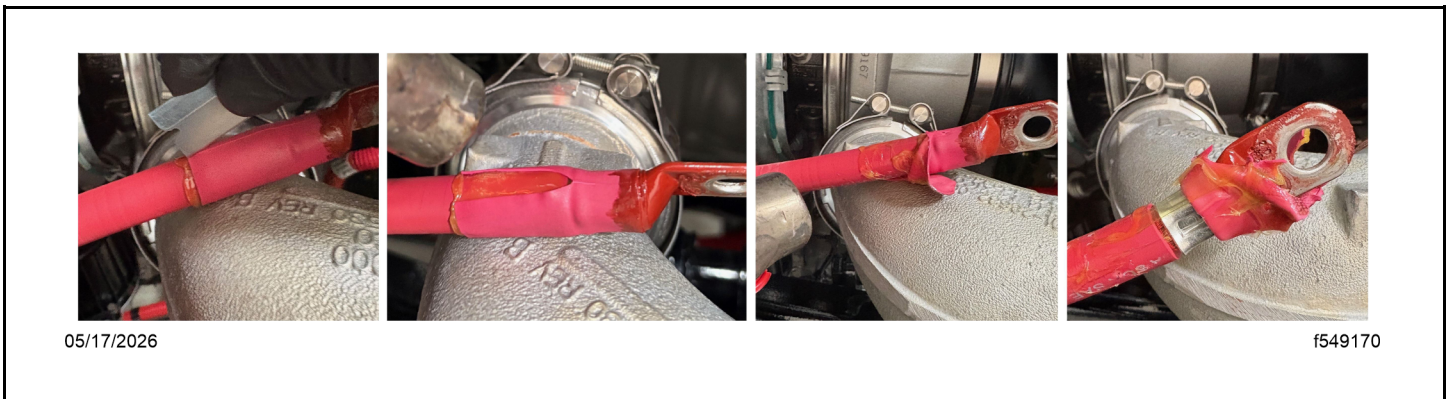

Fig 5, Heat Shrink Removal

- c. Cut the cable just above the ring terminal.
- d. Remove the cable insulation equal to half the butt connector length without damaging the wire strands. See Fig. [Fig. 6](#).

F1029 A-O

Creation Date: May 2026

NHTSA #26V-079

Transport Canada #2026-054



Fig 6, Removing the Insulation

e. Straighten any bent strands of the conductor.

NOTE: To ensure proper crimp force is applied to the terminal, the cable cuts must be square and the number of damaged or lost strands must be minimized.

20. Inspect the conductor for evidence of corrosion. Is corrosion present on the newly exposed conductor?

NOTE: The cable must be replaced if cutting back the corrosion causes the cable to become too short for the butt terminal to be supported by the routing clamp above the frame rail.

a. **YES** → Cut off about 1 inch (25 mm) of the cable. Repeat steps 19d through 19e to remove the cable insulation. Evaluate the condition of the conductor.

b. **NO** → Go to step 21.

F1029 A-O

Creation Date: May 2026

NHTSA #26V-079

Transport Canada #2026-054

21. Crimp the butt connector terminal (PHM 8 2980) on the cable routed to the cab. See Fig. [Fig. 7](#).

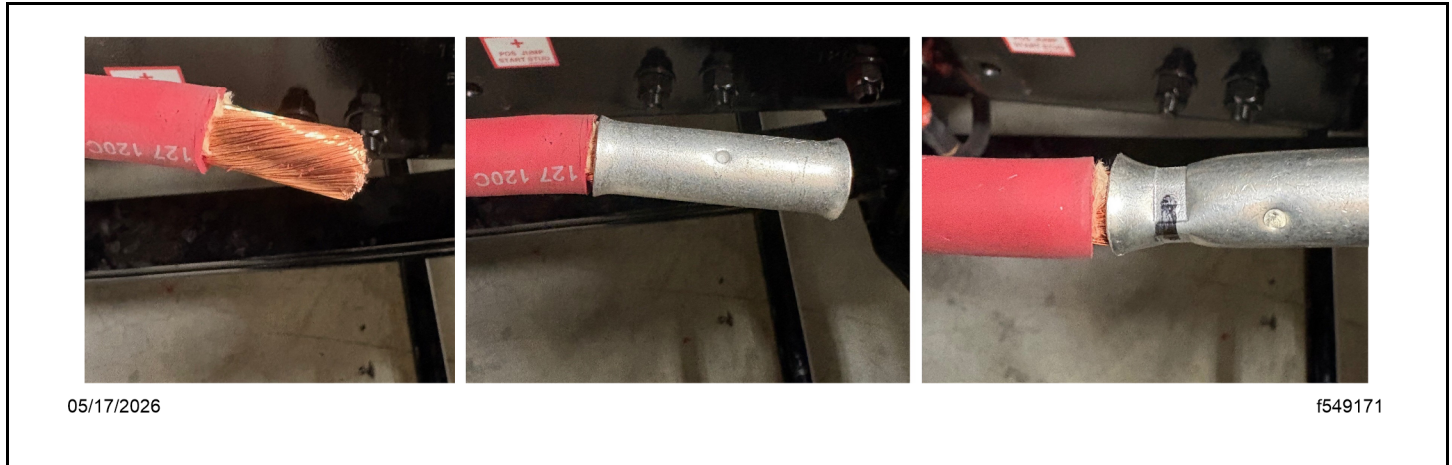

Fig 7, Installing and Crimping the Terminal

- a. Fully seat the conductor in the terminal.
 - b. Adjust the crimping tool to the correct cable size.
 - c. Position the crimping tool approximately 5/16 inch (8 mm) from the open end of the barrel. Crimp the terminal.
- NOTE:** To prevent the cable strands from entering the heat shrink over time, all the cable strands must be inserted into the terminal. If the cable strands are outside the barrel, wind them around the conductor in the gap between the cable insulation and the terminal. Apply electrical tape over the gap to prevent them from contacting the heat shrink layer.
22. Install the new starter cable (A06-78035-065) on the positive terminal on the starter. Tighten 19 lbf-ft (26 N·m).
 23. Apply dielectric red enamel paint to the exposed surfaces of the cable ends at the starter.
 24. Install the 5/8 inch (16 mm) tie block (23-13805-062) on the top isolator bracket frame bolt.

F1029 A-O

Creation Date: May 2026

NHTSA #26V-079

Transport Canada #2026-054

25. Route the starter cable next to the other heavy positive cable(s) from the starter to the lower frame rail support bracket. See Fig. [Fig. 8](#).

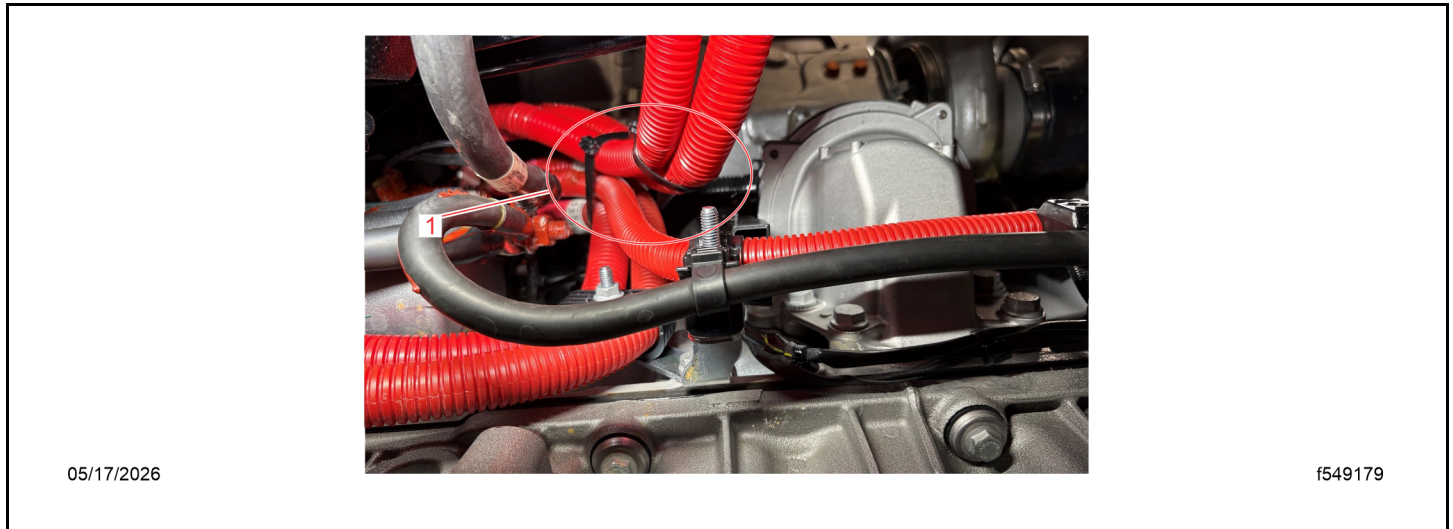

Fig 8, Securing the Cables

1. Secured Cables

26. Determine the ideal length for the new starter cable between the starter and butt connector. Cut the cable. See Fig. [Fig. 9](#).

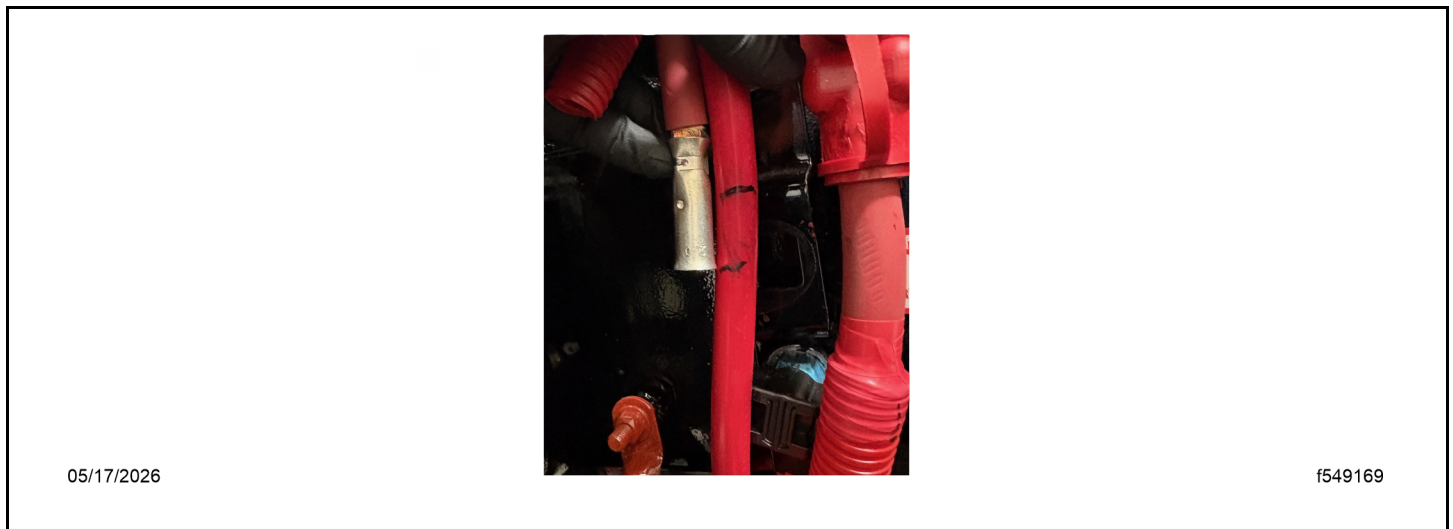

Fig 9, Determining the Starter Cable Length

F1029 A-O

Creation Date: May 2026

NHTSA #26V-079

Transport Canada #2026-054

27. Position three pieces of heat shrink tubing (66-47062-000) on the starter cable with one on the upper cable and two on the lower cable.

NOTE: To ensure a watertight connection, position the heat shrink tube to allow enough room to complete the butt crimp process without damaging it. If the heat shrink is damaged or splits during heating, replace the terminal.

28. Crimp the butt connector.
- Remove the cable insulation equal to half the butt connector length without damaging the wire strands.
 - Straighten any bent conductor strands.
 - Fully seat the conductor in the terminal.
 - Adjust the crimping tool to the correct cable size.
 - Crimp the terminal.

29. Insulate the butt connection with heat shrink sleeves. See Fig. [Fig. 10](#).

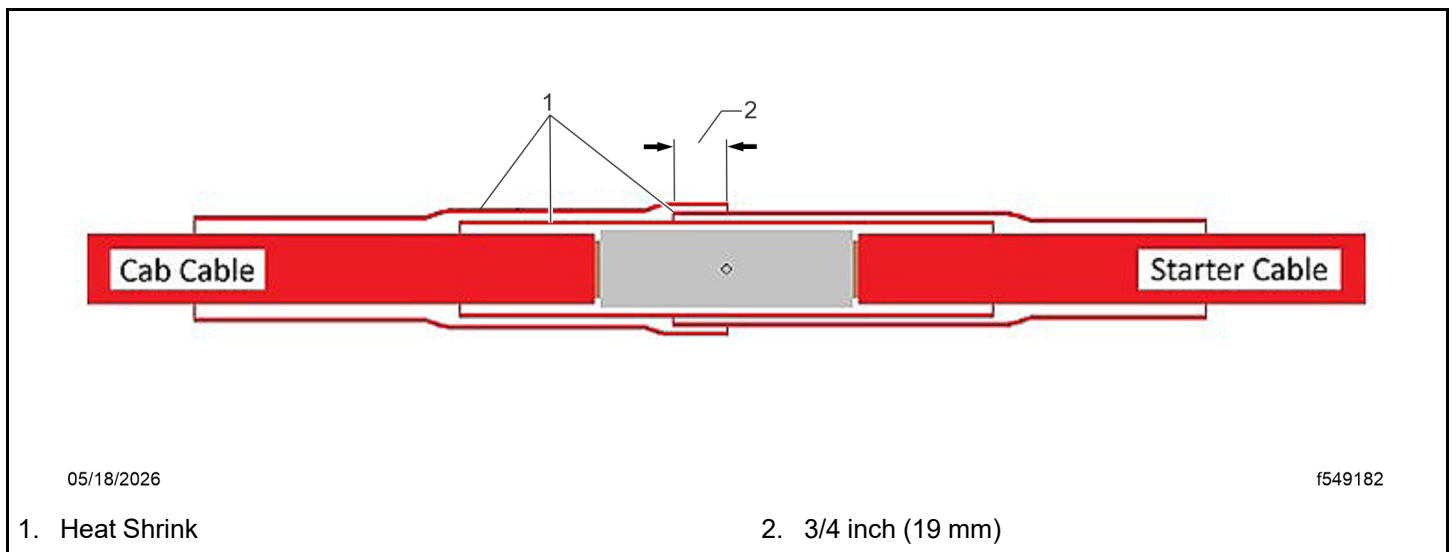

Fig 10, Heat Shrink Insulation

- Center the first piece of heat shrink sleeve on the terminal.
- Activate the sleeve by heating it evenly from one end until it adapts to the size of the cable and the adhesive liquefies.
- Continue heating the sleeve on all sides, working from one end to the other.
- Confirm a continuous ring of adhesive can be seen around the circumference of the sleeve at both ends.
- Position the second sleeve on the lower cable and overlap the center of the first sleeve by 3/4 inch (19 mm).
- Activate the second sleeve by heating it evenly from one end until it adapts to the size of the cable and the adhesive liquefies.
- Continue heating the second sleeve on all sides, working from one end to the other.

F1029 A-O

Creation Date: May 2026

NHTSA #26V-079

Transport Canada #2026-054

- h. Confirm a continuous ring of adhesive can be seen around the circumference of the second sleeve at both ends.
 - i. Position the third sleeve on the upper cable and overlap the top of the second sleeve by 3/4 inch (19 mm).
 - j. Activate the third sleeve and inspect for a continuous ring of sealant at both ends.
30. Cover the heat shrink joint with convolute tubing. If extra convolute tubing is required, use 4/0 Red Slit Convolute (48-25360-022) for 4/0 cables, and CONDUIT-NYL, 19MM, FLEX (48-25360-019) for 2/0 cables.
31. Apply red electrical tape to the cable and to the convolute end to create a seamless transition between the ends of the convolute.
32. Install the upper and lower cable clamps on the isolator frame bracket. To prevent cables (A) from rubbing, secure any cables routed on the outside the cable clamps (B), using butterfly cable ties (C). See Fig. Fig. 11.

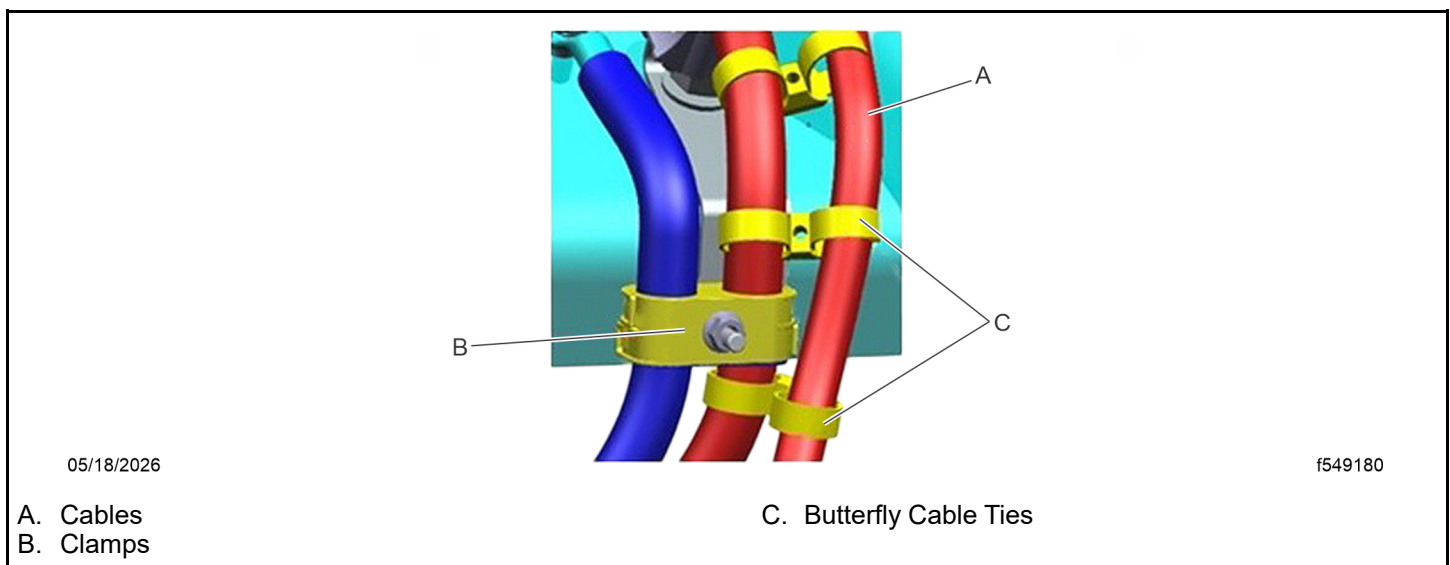

Fig 11, Butterfly Cable Ties Around the Cable Clamps

33. Secure the cables to the 5/8 inch (16 mm) tie block with a Heavy Duty (HD) cable tie (23-13476-000) and other points where positive power cables are routed together.
34. Use butterfly cable ties (TYCDCT110HIR) to route positive cables next to any other cables or anywhere along the path where cables must be separated.
- IMPORTANT: Ensure no power cables are rubbing, or close to rubbing, on frame or engine components.
35. If removed, install the splash shield behind the front tire. For detailed instructions, see Group 88 of the 47X, 48X and 49X Workshop Manual.
36. Install the negative cable connections at the batteries.
37. Clean a spot on the base label (Form WAR259) and attach a campaign completion sticker for F1029 (Form WAR260).

F1029 A-O

Creation Date: May 2026

NHTSA #26V-079

Transport Canada #2026-054

Group B Work Instructions

1. Check the base label (Form WAR259) for a completion sticker for F1029 (Form WAR260), indicating this work has been done. The base label is usually located on the passenger-side door, about 12 inches (30 cm) below the door latch. If a completion sticker is present, no work is needed. If a completion sticker is not present, proceed to the next step.
2. Park the vehicle on a level surface and set the parking brake. Chock the rear tires.
3. Turn the steer wheels to the left side to make the isolated stud accessible. Shut down the engine.
4. Open the hood.
5. Locate the isolated positive (+) battery stud mounted on the frame behind the front wheel. See Fig. [Fig. 12](#).

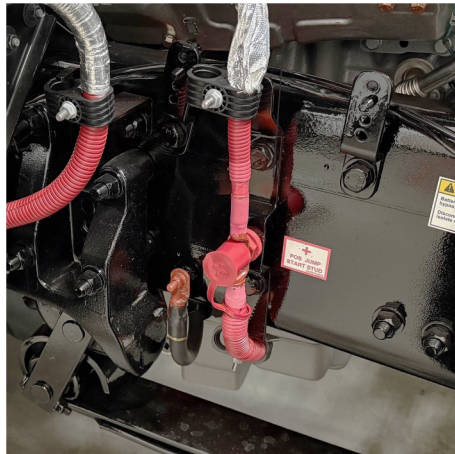

05/17/2026

f549174

Fig 12, Isolated Battery Junction with Jump-Start Post

6. Remove the negative (-) cable connection(s) from the batteries.
7. If required for access, remove the splash shield from behind the front tire. For detailed instructions, see Group 88 of the *47X, 48X and 49X Workshop Manual*
8. Remove the jump-start post or nut that secures the battery cable(s) to the isolated stud.
9. Remove the clamp(s) that secure the positive battery cables to the clipping point above the frame rail.
10. Remove the clamp(s) and ties that secure the positive battery cable routed between the isolated stud and the starter.
11. Remove the nut that secures the positive battery cables to the starter.
12. Remove the cable that connects the isolated stud to the starter.
13. Remove the bolts that secure the isolated stud bracket to the frame.
14. Remove the isolated stud from the frame bracket.
15. Install the lower isolator bracket frame bolt in position with the head on the inboard side of the frame.

F1029 A-O

Creation Date: May 2026

NHTSA #26V-079

Transport Canada #2026-054

16. Install the isolator bracket, washer, and nut. Hand-tighten the fasteners to keep the bracket in position.
17. Install the jump-start cable bracket (12-25410-000) on the upper frame bolt followed by the washer. Position the bracket in the frame hole and tighten to keep it in position.
18. Remove the ring terminal from the positive cable that is routed to the cab.
 - a. Note how the cable is secured and remove any cable ties, tape, or convolute as needed to uncover at least 6 inches of the cable.
 - b. Remove the original heat shrink. To do so, heat it, score it, and continue to heat it until the score splits and the adhesive softens. See Fig. [Fig. 13](#).

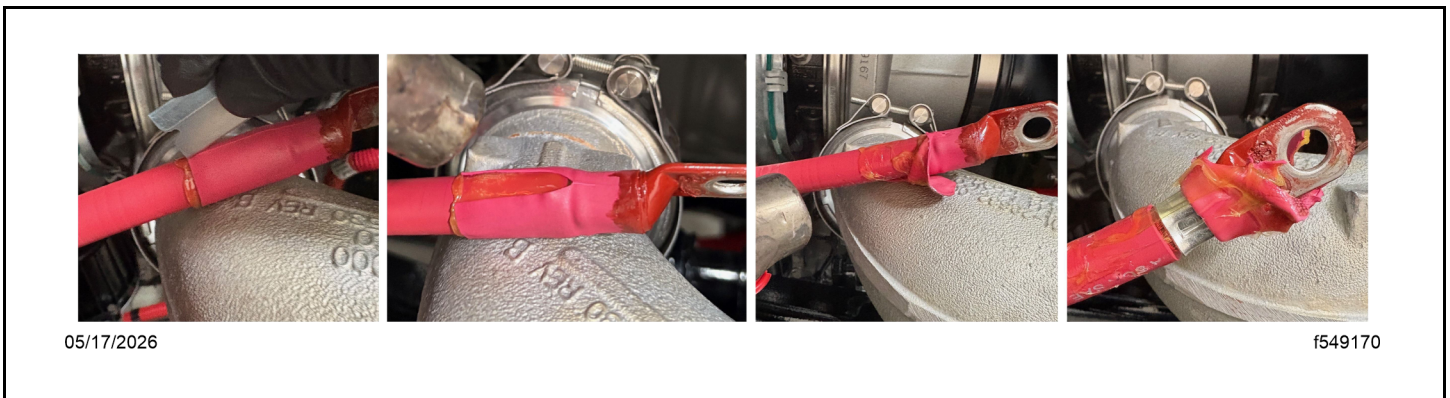

Fig 13, Heat Shrink Removal

- c. Cut the cable just above the ring terminal.
 - d. Remove the cable insulation equal to half the butt connector length without damaging the wire strands.
 - e. Straighten any bent strands of the conductor.
- NOTE:** To ensure proper crimp force is applied to the terminal, the cable cuts must be square and the number of damaged or lost strands must be minimized.
19. Inspect the conductor for evidence of corrosion. Is corrosion present on the newly exposed conductor?

NOTE: The cable must be replaced if cutting back the corrosion causes the cable to become too short for the butt terminal to be supported by the routing clamp above the frame rail.

 - a. **YES** → Cut off about 1 inch (25mm) of cable. Repeat steps 18d through 18e to remove the cable insulation. Evaluate the condition of the conductor.
 - b. **NO** → Go to step 20.
 20. Crimp the butt connector terminal (PHM 8 2980) on the cable routed to the cab.
 - a. Fully seat the conductor in the terminal.
 - b. Adjust the crimping tool to the correct cable size.
 - c. Position the crimping tool approximately 5/16 inch (8mm) from the open end of the barrel. Crimp the terminal.

F1029 A-O

Creation Date: May 2026

NHTSA #26V-079

Transport Canada #2026-054

NOTE: To prevent the cable strands from entering the heat shrink over time, all the cable strands must be inserted into the terminal. If the cable strands are outside the barrel, wind them around the conductor in the gap between the cable insulation and the terminal. Apply electrical tape over the gap to prevent them from contacting the heat shrink layer.

21. Determine the length of the new jump-start cable (A66-12311-046).
 - a. Compare the old starter cable to the new jump-start cable.
 - b. Remove the tape securing the convolute cover to access the cable.
 - c. Hold the jump-start cable up to the mounting hole on the support bracket.
 - d. Feed the cable under the frame following the path of the other cable(s) to the starter. Mark the cable where it passes the base of the positive post on the starter.
22. Adjust the length of the new jump-start cable and replace the starter-end terminal.
 - a. Remove the tape securing the convolute cover on the cable, if present.
 - b. Cut the cable squarely at the length determined in step 21.
 - c. Position the 4/0 diameter heat shrink sleeve (66-47062-000) on the cable.
 - d. Remove a minimum of 1.2 inch (32mm) of the cable insulation without damaging the wire strands.
 - e. Straighten any bent strands of the conductor.
 - f. Fully seat the conductor in the terminal (23-13773-004).
 - g. Position the new terminal according to the orientation drawing. See Fig. [Fig. 14](#).

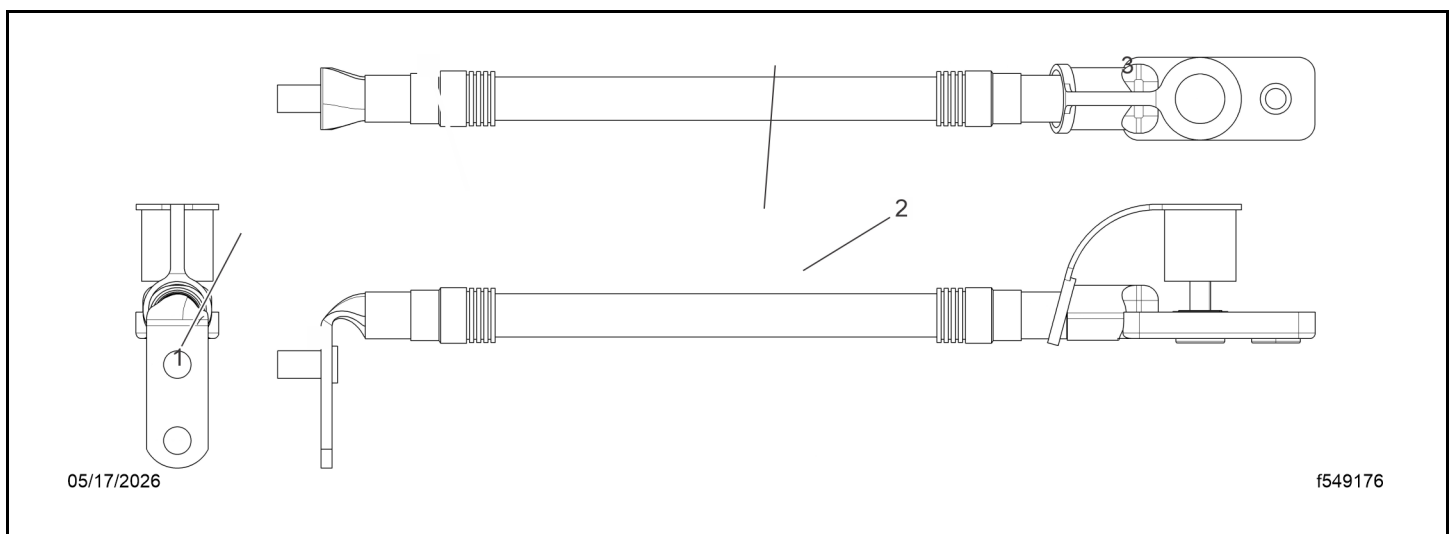

Fig 14, Jump-Start Cable Orientation

- h. Adjust the crimping tool to the correct cable size.
- i. Position the crimping tool approximately 3/8 inch (9mm) from the open end of the barrel and crimp the terminal.

F1029 A-O

Creation Date: May 2026

NHTSA #26V-079

Transport Canada #2026-054

NOTE: If the new jump-start cable terminal doesn't fit over the conductor easily, deburr the inside diameter of the barrel opening.

NOTE: If the strands of the conductor are too frayed to fit into the terminal barrel, use a small cable tie to make two wraps around the conductor near the end of the insulation. Tighten the tie and push it towards the end of the conductor to compact the strands. Stop with enough remaining conductor to start the terminal, push it on, and remove the tie.

23. Apply heat shrink to the cable.
 - a. Slide the heat shrink into position on the terminal.
 - b. Activate the heat shrink sleeve by heating it evenly at one end until it adapts to the size of the terminal and the adhesive liquefies. Continue heating the sleeve on all sides, working from one end to the other.
 - c. Confirm a continuous ring of adhesive can be seen around the circumference of the sleeve at both ends. See Fig. [Fig. 15](#).

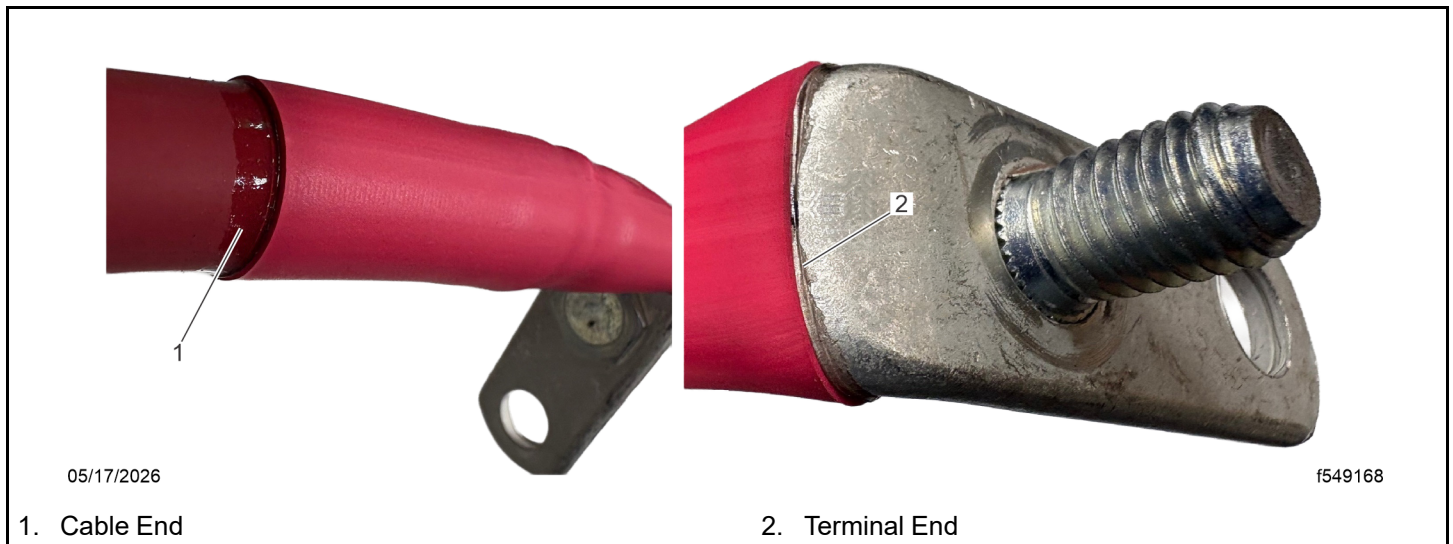

Fig 15, Continuous Adhesive Seal at Cable and Terminal Ends

- d. Install the convolute cover by applying red electrical tape to cover the transition from the heat shrink to the convolute cover. See Fig. [Fig. 16](#).

F1029 A-O

Creation Date: May 2026

NHTSA #26V-079

Transport Canada #2026-054

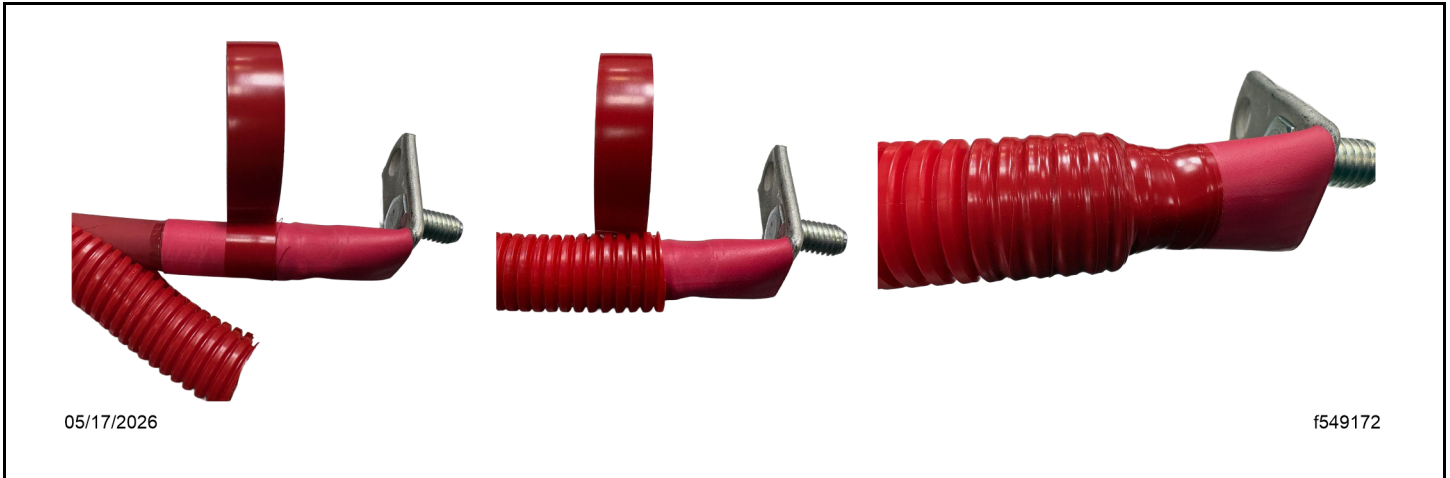

Fig 16, Installing the Convolute Cover

24. Install the new starter cable (A06-78035-065) on the positive terminal on the starter.
25. Install the jump-start cable assembly on the starter. Tighten 19 lbf·ft (26 N·m).
26. Apply dielectric red enamel paint to the exposed surfaces of the cable ends at the starter.
27. Install the 5/8 inch (16 mm) tie block (23-13805-062) on the bottom isolator bracket frame bolt so the cable routing can be set passing by it. See Fig. [Fig. 17](#).

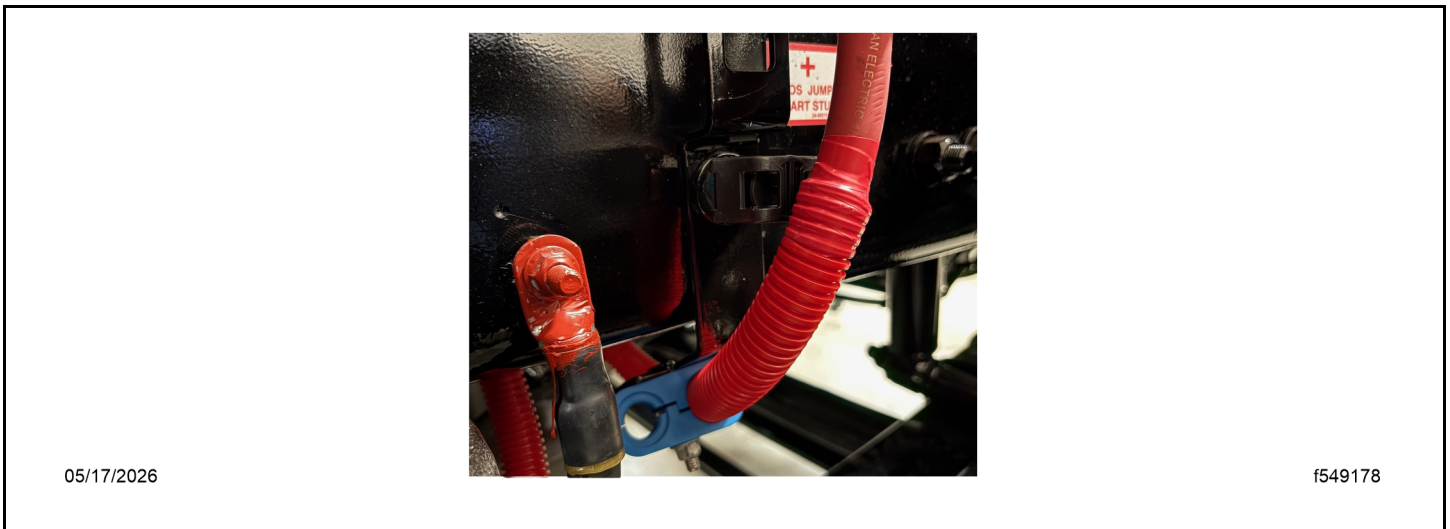

Fig 17, Routing Over the Tie Block

F1029 A-O

Creation Date: May 2026

NHTSA #26V-079

Transport Canada #2026-054

28. Route the starter and jump-start cables next to the other heavy positive cable(s) from the starter to the lower frame rail support bracket. See Fig. Fig. 18.

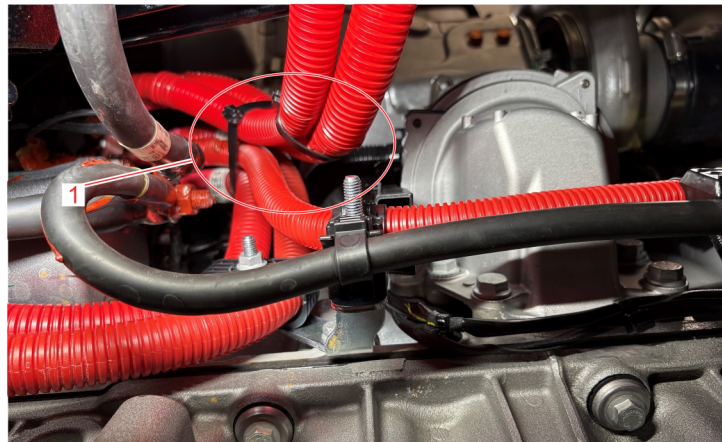

05/17/2026

f549179

Fig 18, Securing the Cables

1. Secured Cables
29. Use the lower routing clamp to support the 4/0 positive starter cable, as it routes under the frame, and route the jump-start cable next to it.

F1029 A-O

Creation Date: May 2026

NHTSA #26V-079

Transport Canada #2026-054

30. Route the jump-start cable to the support bracket and the bolt (N910105 008016), cable, washer (23-10900-038), and nut (23-12612-008). Hand-tighten the fasteners. See Fig. [Fig. 19](#).



Fig 19, Jump-Start Cable Support Bracket

31. Remove the 5/8" tie block and tighten the frame bolts that secure the isolator bracket to the frame rail to 148 lbf·ft (200 N·m).
32. If required, apply touch-up paint to the frame bolts.
33. Install the 5/8" tie block (23-13805-062) on the bottom of the isolator bracket frame bolt.

F1029 A-O

Creation Date: May 2026

NHTSA #26V-079

Transport Canada #2026-054

34. Determine the ideal length for the new starter cable between the starter and butt connector. Cut the cable. See Fig. [Fig. 20](#).

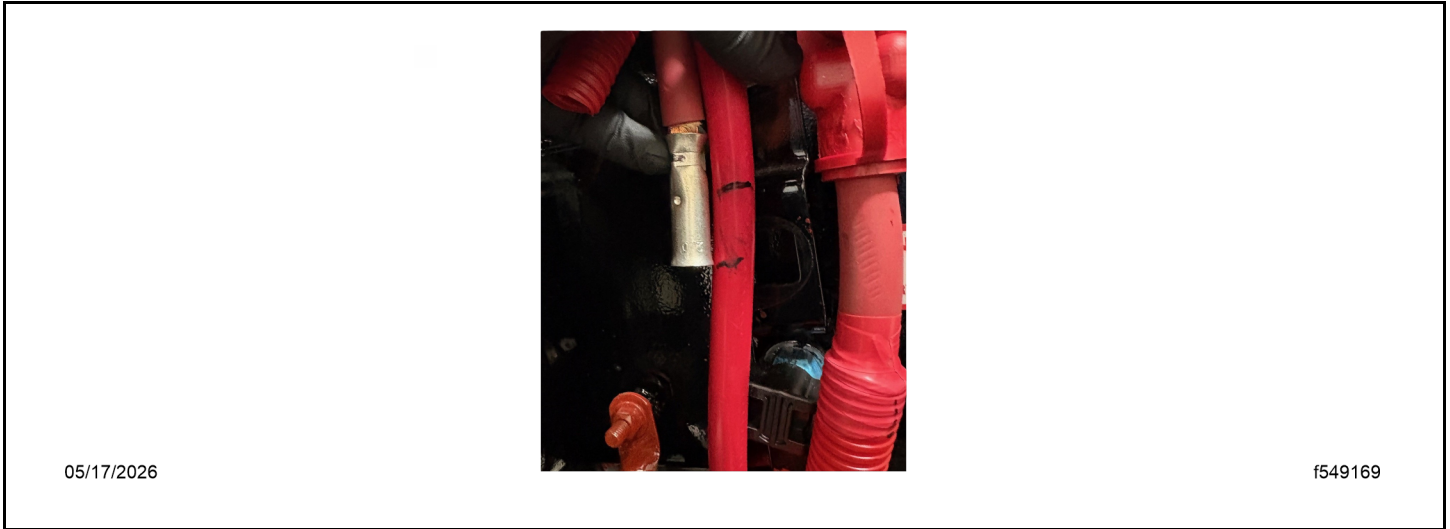

Fig 20, Determining the Starter Cable Length

35. Position three pieces of heat shrink tubing (66-47062-000) on the starter cable with one on the upper cable and two on the lower cable.
- NOTE:** To ensure a watertight connection, position the heat shrink tube to allow enough room to complete the butt crimp process without damaging it. If the heat shrink is damaged or splits during heating, replace the terminal.
36. Crimp the butt connector.
- Remove the cable insulation equal to half the butt connector length without damaging the wire strands.
 - Straighten any bent conductor strands.
 - Fully seat the conductor in the terminal.
 - Adjust the crimping tool to the correct cable size.
 - Crimp the terminal.

F1029 A-O

Creation Date: May 2026

NHTSA #26V-079

Transport Canada #2026-054

37. Insulate the butt connection with heat shrink sleeves. See Fig. Fig. 21.

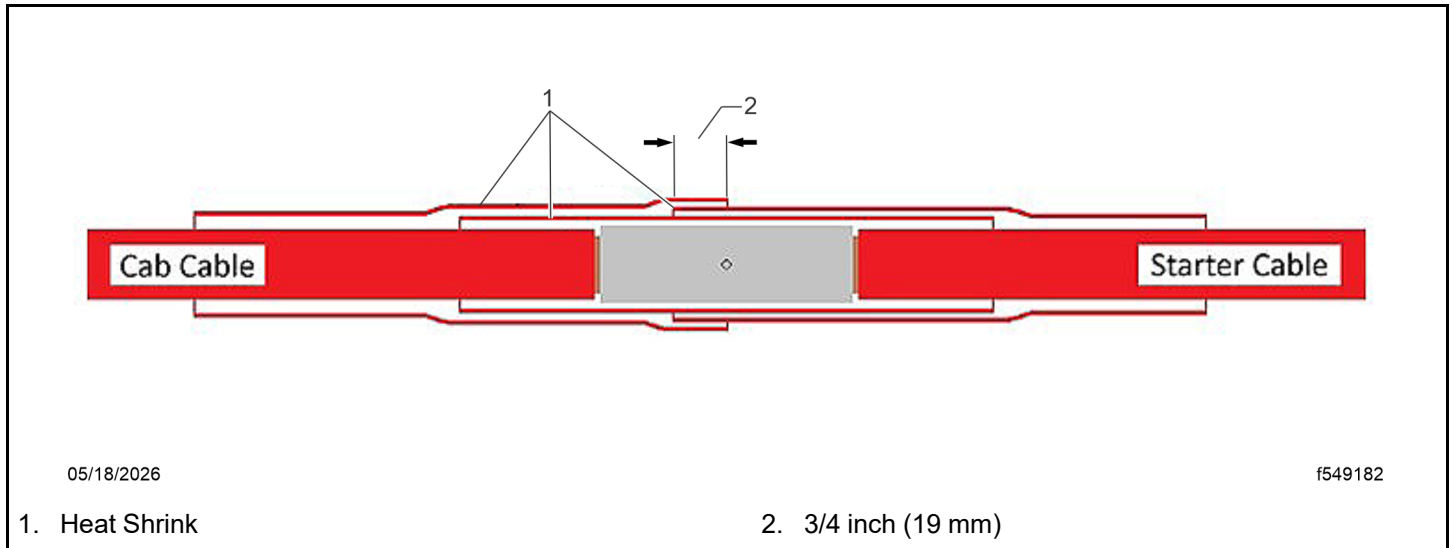

Fig 21, Heat Shrink Insulation

- a. Center the first piece of heat shrink sleeve on the terminal.
 - b. Activate the sleeve by heating it evenly from one end until it adapts to the size of the cable and the adhesive liquefies.
 - c. Continue heating the sleeve on all sides, working from one end to the other.
 - d. Confirm a continuous ring of adhesive can be seen around the circumference of the sleeve at both ends.
 - e. Position the second sleeve on the lower cable and overlap the center of the first sleeve by 3/4 inch (19mm).
 - f. Activate the second sleeve by heating it evenly from one end until it adapts to the size of the cable and the adhesive liquefies.
 - g. Continue heating the second sleeve on all sides, working from one end to the other.
 - h. Confirm a continuous ring of adhesive can be seen around the circumference of the second sleeve at both ends.
 - i. Position the third sleeve on the upper cable and overlap the top of the second sleeve by 3/4 inch (19mm).
 - j. Activate the third sleeve and inspect for a continuous ring of sealant at both ends.
38. Cover the heat shrink joint with convolute tubing. If extra convolute tubing is required, use 4/0 Red Slit Convolute (48-25360-022) for 4/0 cables, and CONDUIT-NYL, 19MM, FLEX (48-25360-019) for 2/0 cables.
39. Apply red electrical tape to the cable and to the convolute end to create a seamless transition between the ends of the convolute.

F1029 A-O

Creation Date: May 2026

NHTSA #26V-079

Transport Canada #2026-054

40. Install the upper and lower cable clamps on the isolator frame bracket. To prevent cables (A) from rubbing, secure any cables routed on the outside the cable clamps (B), using butterfly cable ties (C). See Fig. Fig. 22.

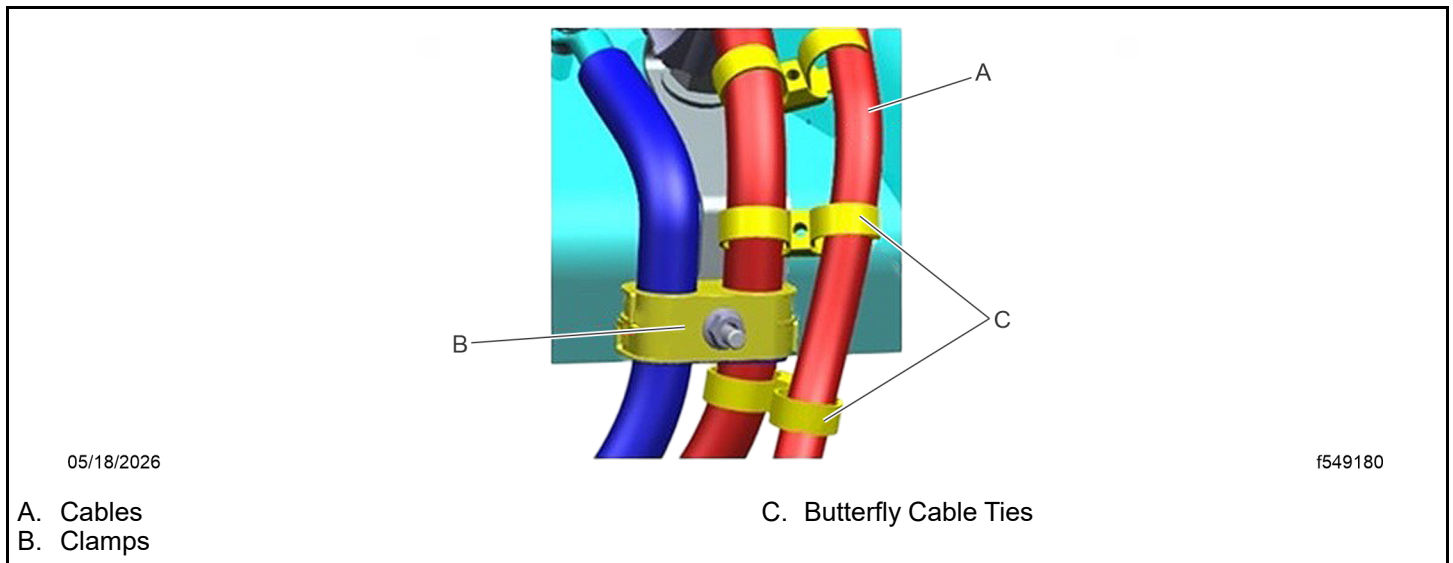

Fig 22, Butterfly Cable Ties Around the Cable Clamps

41. Secure the cables to the 5/8 inch (16 mm) tie block with a Heavy Duty (HD) cable tie (23-13476-000) and other points where positive power cables are routed together.
42. Use butterfly cable ties (TYCDCT110HIR) to route positive cables next to any other cables or anywhere along the path where cables must be separated.
IMPORTANT: Ensure no power cables are rubbing, or close to rubbing, on frame or engine components.
43. Remove the nut that secures the jump-start cable to the support bracket. Apply medium strength thread locker. Install the nut and tighten 14 lbf·ft (19 N·m).

F1029 A-O

Creation Date: May 2026

NHTSA #26V-079

Transport Canada #2026-054

44. Install the nylon nut (23-13379-001) on the tail of the bolt that secures the jump-start cable to the support bracket (1). Tighten the nut 7 lbf·ft (9.5Nm). See Fig. [Fig. 23](#).



Fig 23, Nylon Nut on Jump-Start Bracket Fastener

1. Nylon Nut
45. If removed, install the splash shield behind the front tire. For detailed instructions, see Group 88 of the *47X, 48X and 49X Workshop Manual*.
46. Install the negative cable connections at the batteries.
47. Clean a spot on the base label (Form WAR259) and attach a campaign completion sticker for F1029 (Form WAR260).

F1029 A-O

Creation Date: May 2026

NHTSA #26V-079

Transport Canada #2026-054

Group C Work Instructions

1. Check the base label (Form WAR259) for a completion sticker for F1029 (Form WAR260), indicating this work has been done. The base label is usually located on the passenger-side door, about 12 inches (30 cm) below the door latch. If a completion sticker is present, no work is needed. If a completion sticker is not present, proceed to the next step.
2. Park the vehicle on a level surface and set the parking brake. Chock the rear tires.
3. Turn the steer tires to the right to make the isolated stud accessible. Shut down the engine.
4. Open the hood.
5. Locate the isolated positive battery stud mounted on the frame behind the front tire. See Fig. [Fig. 24](#).

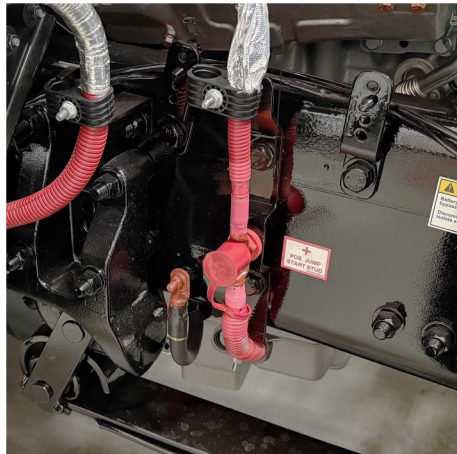

05/17/2026

f549174

Fig 24, Isolated Battery Junction with Jump-Start Post

6. Remove the negative cable connection(s) from the batteries.
7. If required for access, remove the splash shield from behind the front tire. For detailed instructions, see Group 88 of the *47X, 48X and 49X Workshop Manual*.
8. Remove the jump-start post or nut securing the battery cables to the isolated stud.
9. Remove the clamp(s) securing the positive battery cable(s) to the clipping point above the frame rail.
10. Remove the clamp(s) and ties securing the positive cable routed between the isolated stud and starter.
11. Remove the nut securing the positive battery cables to the starter.
12. Remove the cable connecting the isolated stud to the starter.
13. Remove the bolt securing the lower cable routing bracket to the frame.
14. Install the jump-start cable bracket (12-25410-000), washer, and cable routing bracket on the frame bolt. Install the assembly in the frame hole.

F1029 A-O

Creation Date: May 2026

NHTSA #26V-079

Transport Canada #2026-054

15. Install the frame fastener nut. Tighten the nut to allow the brackets to remain loose.
16. Position the jump-start support bracket bolt (N910105 008016) in the bracket.
NOTE: The bolt that secures the jump-start cable to the support bracket may be too long to be installed when the frame bolt is tight. It should be positioned in the bracket hole before tightening the frame bolt.
17. Align the routing and jump-start support brackets vertically on the frame. Tighten the frame bolt 148 lbf·ft (200 N·m).
18. Remove the isolated stud bracket from the frame.
19. Remove the stud from the bracket.
20. Install the isolated stud bracket.
 - a. Find the frame bolt closest to the square stud mounting hole. Position the bolt with the head on the inboard side of the frame.
 - b. Install the routing bracket, washer, and hand-start the nut.
 - c. Install the second frame bolt with the head on the outboard side of the frame.
 - d. Tighten both bolts 148 lbf·ft (200 N·m).
21. If required, apply touch-up paint to the frame bolts.
22. Remove the ring terminal from the positive cable routed to the cab.
NOTE: To ensure proper crimp force is applied to the terminal, the cable cuts must be square and the number of damaged or lost strands must be minimized.
 - a. Note how the cables are secured and remove any cable ties, tape, or convolute as needed to uncover at least 6 inches of the cable.
 - b. Remove the original heat shrink. To do so, heat it, score it, and continue to heat it until the score splits and the adhesive softens. See Fig. [Fig. 25](#).

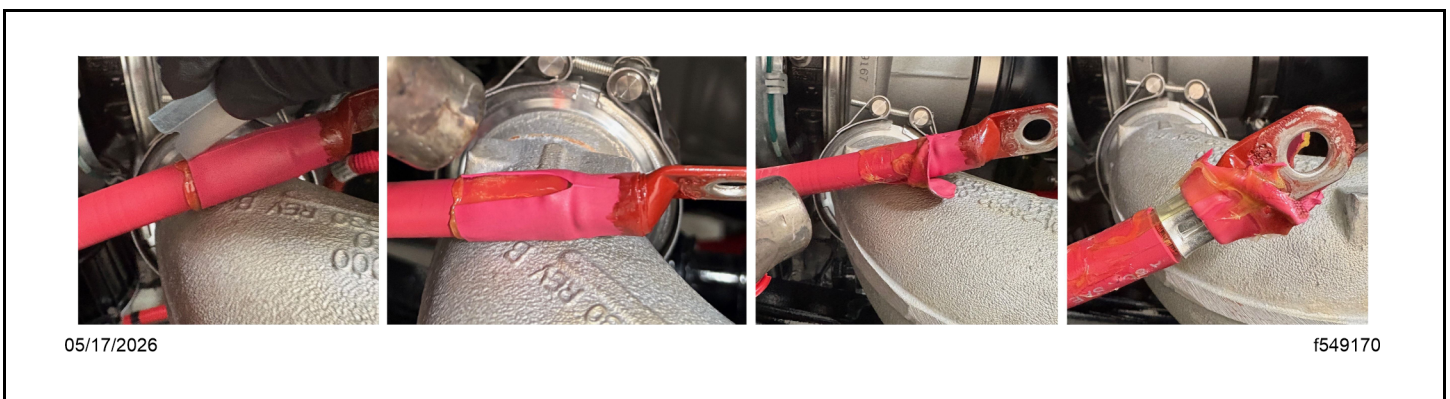

Fig 25, Heat Shrink Removal

- c. Cut the cable just above the ring terminal.

F1029 A-O

Creation Date: May 2026

NHTSA #26V-079

Transport Canada #2026-054

- d. Remove the cable insulation equal to half the butt connector length, without damaging the wire strands. See Fig. Fig. 26.

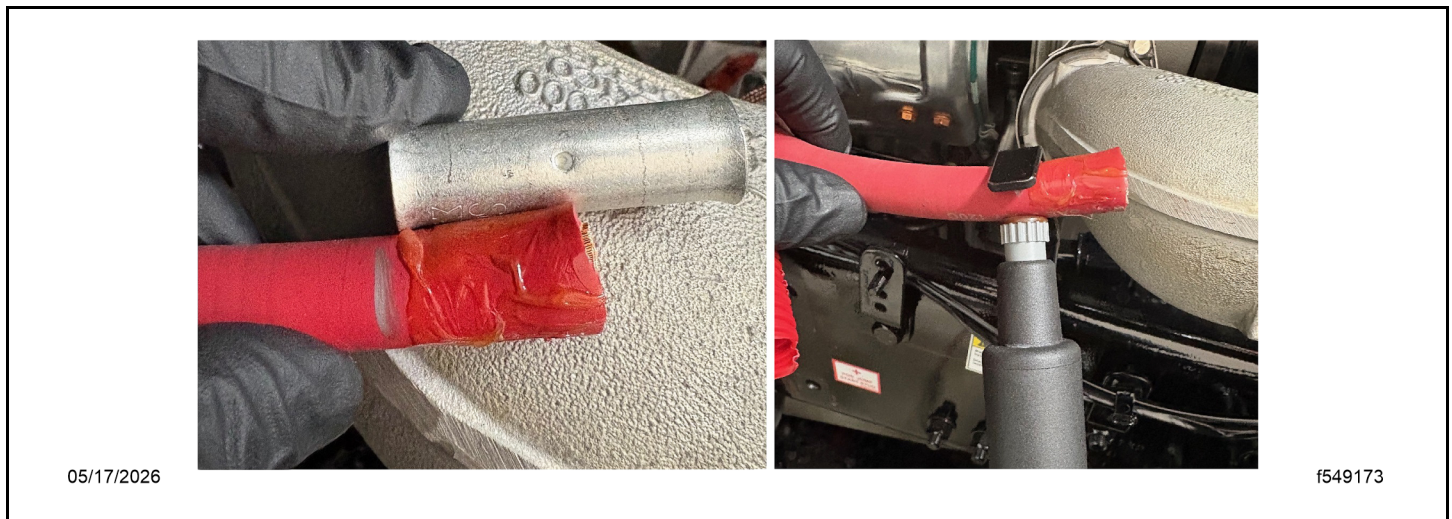

Fig 26, Removing the Insulation

- e. Straighten any bent strands of the conductor.
23. Inspect the conductor for evidence of corrosion. Is corrosion present on the newly exposed conductor?
- NOTE:** The cable must be replaced if cutting back the corrosion causes the cable to become too short for the butt terminal to be supported by the routing clamp above the frame rail.
- a. **YES** → Cut off about 1 inch (25 mm) of the cable. Repeat steps 23d through 23e to remove the cable insulation. Evaluate the condition of the conductor.
- b. **NO** → Go to step 24.
24. Crimp the butt connector terminal (PHM 8 2980) on the cable routed to the cab.
- a. Fully seat the conductor in the terminal.
- b. Adjust the crimping tool to the correct cable size.
- c. Position the crimping tool approximately 5/16 inch (8 mm) from the open end of the barrel. Crimp the terminal.
- NOTE:** To prevent the cable strands from entering the heat shrink over time, all the cable strands must be inserted into the terminal. If the cable strands are outside the barrel, wind them around the conductor in the gap between the cable insulation and the terminal. Apply electrical tape over the gap to prevent them from contacting the heat shrink layer.
25. Determine the length of the new jump-start cable (A66-12311-046).
- a. Compare the old starter cable to the new jump-start cable.
- b. Remove the tape securing the convolute cover to access the cable.
- c. Hold the jump-start cable up to the mounting hole on the support bracket.

F1029 A-O

Creation Date: May 2026

NHTSA #26V-079

Transport Canada #2026-054

- d. Feed the cable under the frame following the path of the other cable(s) to the starter. Mark the cable where it passes the base of the positive post on the starter.
26. Adjust the length of the new jump-start cable. Replace the starter-end terminal.
- a. Remove the tape securing the convolute cover on the cable, if present.
 - b. Cut the cable squarely at the length determined in step 21.
 - c. Position the 4/0 diameter heat shrink sleeve (66-47062-000) on the cable.
 - d. Remove a minimum of 1.2 inch (32 mm) of the cable insulation without damaging the wire strands.
 - e. Straighten any bent strands of the conductor.
 - f. Fully seat the conductor in the terminal (23-13773-004).
 - g. Position the new terminal according to the orientation drawing. See Fig. [Fig. 27](#).

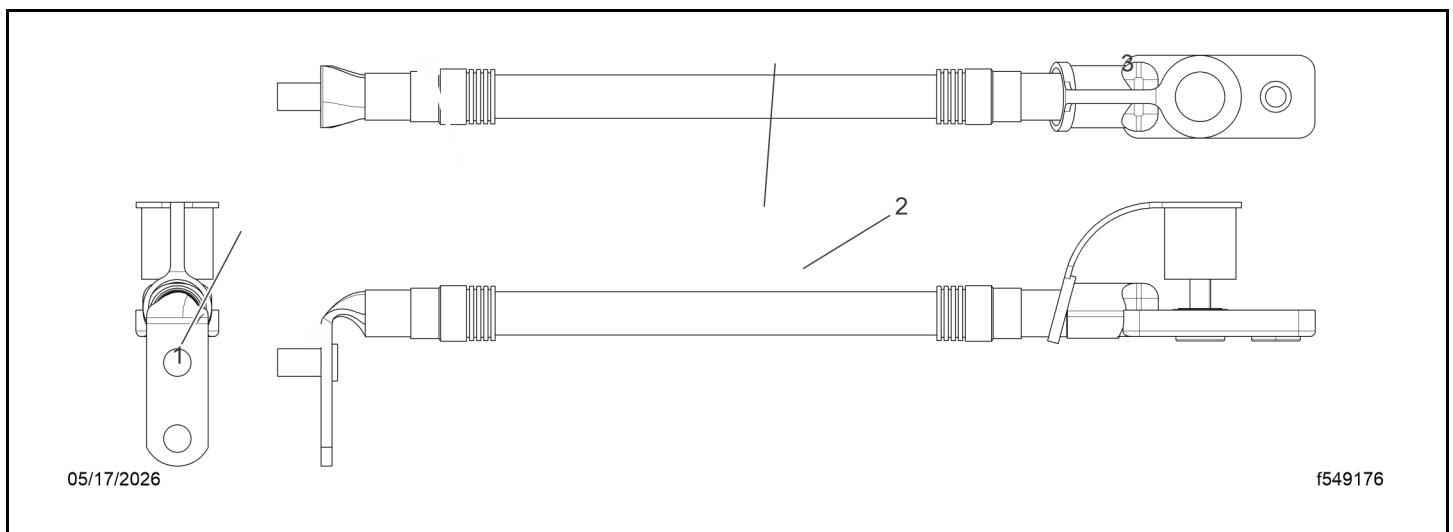

Fig 27, Jump-Start Cable Orientation

- h. Adjust the crimping tool to the correct cable size.
- i. Position the crimping tool approximately 3/8 inch (9mm) from the open end of the barrel and crimp the terminal.

NOTE: If the new jump-start cable terminal does not fit over the conductor easily, deburr the inside diameter of the barrel opening.

NOTE: If the strands of the conductor are too frayed to fit into the terminal barrel, use a small cable tie to make two wraps around the conductor near the end of the insulation. Tighten the tie and push it towards the end of the conductor to compact the strands. Stop with enough remaining conductor to start the terminal, push it on, and remove the tie.

27. Apply heat shrink to the cable.
- a. Slide the heat shrink into position on the terminal.

F1029 A-O

Creation Date: May 2026

NHTSA #26V-079

Transport Canada #2026-054

- b. Activate the heat shrink sleeve by heating it evenly at one end until it adapts to the size of the terminal and the adhesive liquefies. Continue heating the sleeve on all sides, working from one end to the other.
- c. Confirm a continuous ring of adhesive can be seen around the circumference of the sleeve at both ends. See Fig. [Fig. 28](#).

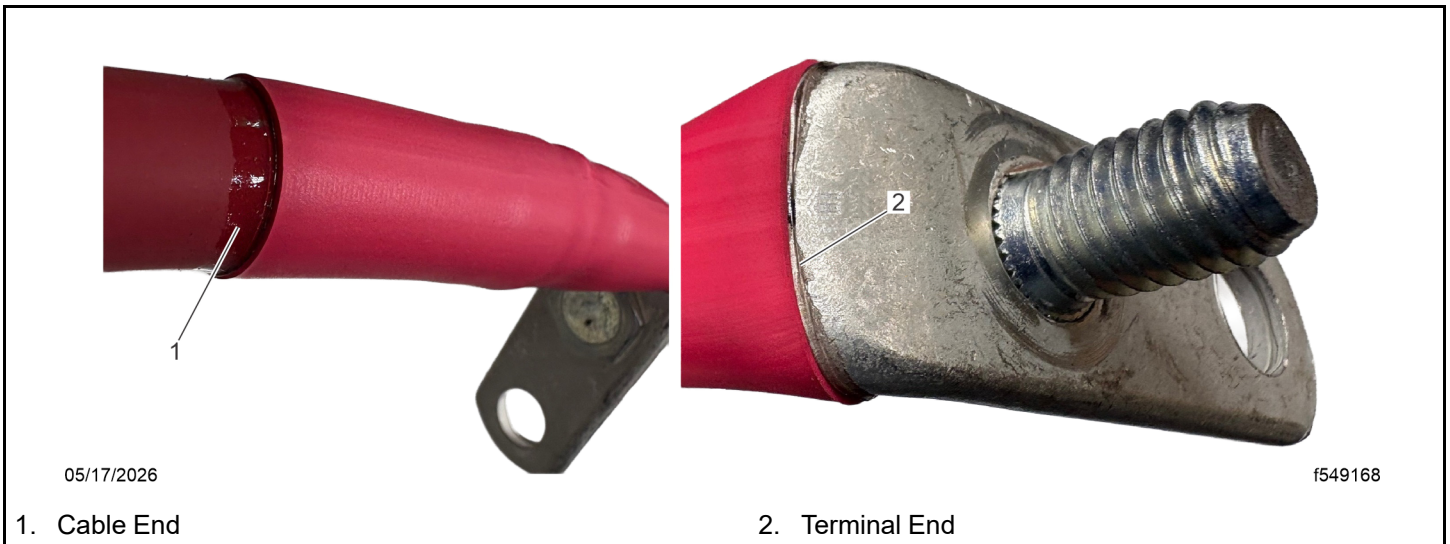

Fig 28, Continuous Adhesive Seal at Cable and Terminal Ends

- d. Install the convolute cover by applying red electrical tape to cover the transition from the heat shrink to the convolute cover. See Fig. [Fig. 29](#).

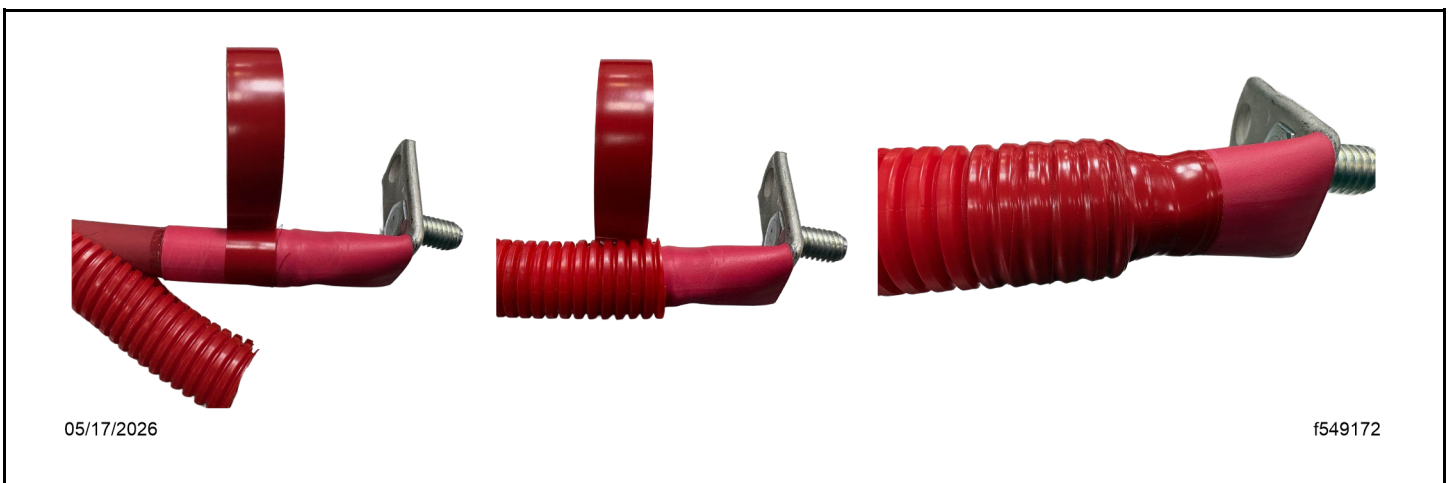

Fig 29, Installing the Convolute Cover

F1029 A-O

Creation Date: May 2026

NHTSA #26V-079

Transport Canada #2026-054

28. Install the new starter cable (A06-78035-065) on the positive terminal of the starter.
29. Install the jump-start cable on the starter. Tighten 19 lbf-ft (26 N·m).
30. Apply dielectric red enamel paint to the exposed surfaces of the cable ends at the starter.
31. Route the starter and jump-start cables next to the other heavy positive cable(s) from the starter to the lower frame rail support bracket. See Fig. [Fig. 30](#).

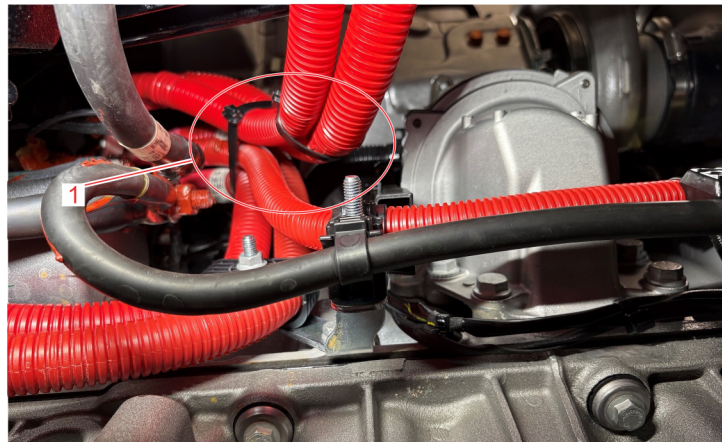

05/17/2026

f549179

Fig 30, Securing the Cables

1. Secured Cables
32. Use the lower routing clamp to support the 4/0 positive starter cable as it routes under the frame. Route the jump-start cable beside it.
33. Route the jump-start cable to the support bracket. Install the cable and washer (23-10900-038). Apply a medium strength thread locker. Tighten the nut (23-12612-008) 14 lbf-ft (19 N·m).

F1029 A-O

Creation Date: May 2026

NHTSA #26V-079

Transport Canada #2026-054

34. Install the nylon nut (23-13379-001) on the tail of the bolt holding the jump-start cable to the support bracket (1). Tighten the nut 84 lbf·in (950 N·cm). See Fig. [Fig. 31](#).



Fig 31, Nylon Nut on Jump-Start Bracket Fastener

1. Nylon Nut

35. Determine the ideal length for the new starter cable between the starter and butt connector. Cut the cable. See Fig. [Fig. 32](#).

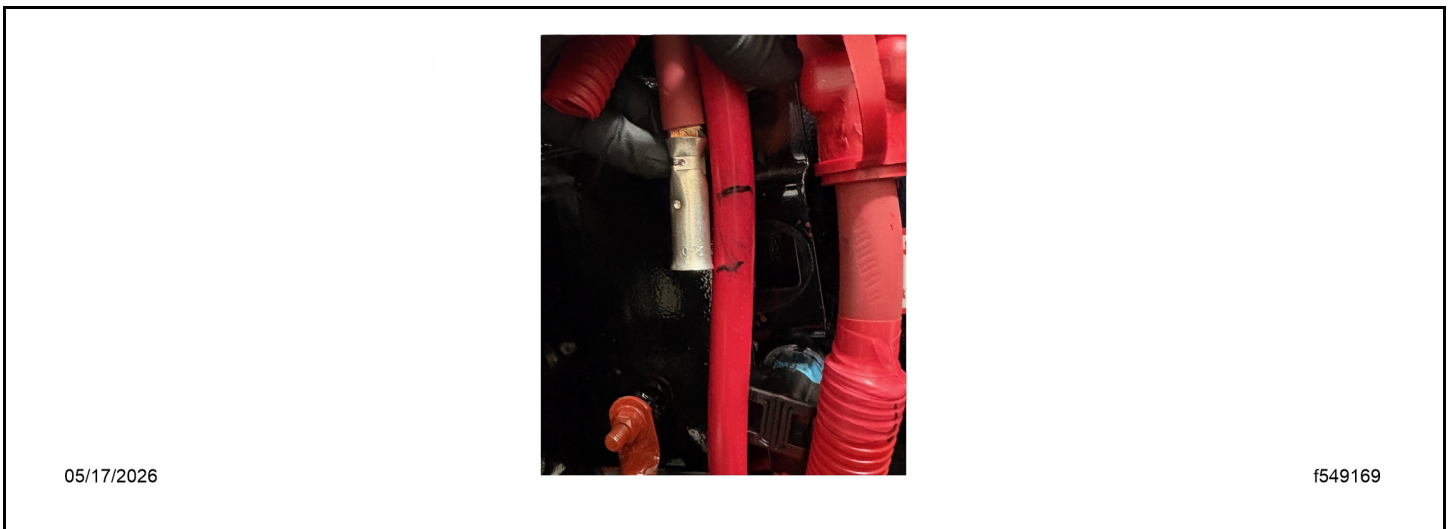

Fig 32, Determining the Starter Cable Length

F1029 A-O

Creation Date: May 2026

NHTSA #26V-079

Transport Canada #2026-054

36. Position three pieces of heat shrink tubing (66-47062-000) on the starter cable with one on the upper cable and two on the lower cable.

NOTE: Position the heat shrink tube to allow enough room to complete the butt crimp process without damaging it. If the heat shrink is damaged and splits during the heating process, the terminal must be replaced to ensure the connection is watertight.

37. Crimp the butt connector.
- Remove the cable insulation equal to half the butt connector length without damaging the wire strands.
 - Straighten any bent conductor strands.
 - Fully seat the conductor in the terminal.
 - Adjust the crimping tool to the correct cable size.
 - Crimp the terminal.
38. Insulate the butt connection with heat shrink sleeves. See Fig. [Fig. 33](#).

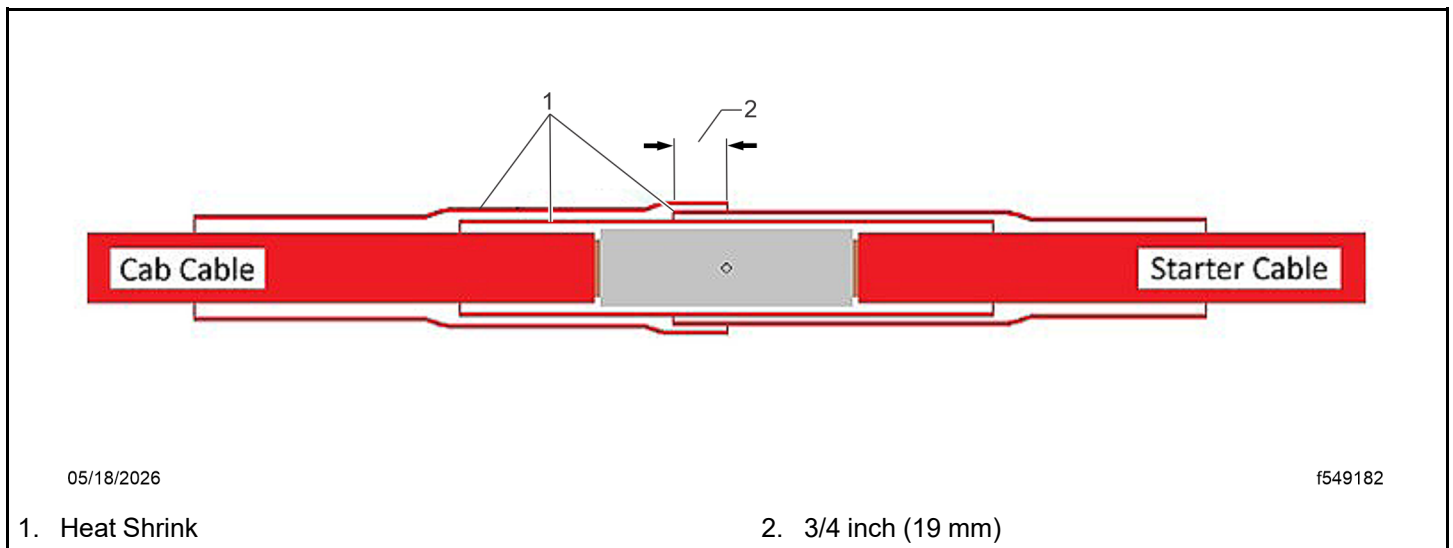

Fig 33, Heat Shrink Insulation

- Center the first piece of heat shrink sleeve on the terminal.
- Activate the sleeve by heating it evenly from one end until it adapts to the size of the cable and the adhesive liquefies.
- Continue heating the sleeve on all sides, working from one end to the other.
- Confirm a continuous ring of adhesive can be seen around the circumference of the sleeve at both ends.
- Position the second sleeve on the lower cable and overlap the center of the first sleeve by 3/4 inch (19 mm).
- Activate the second sleeve by heating it evenly from one end until it adapts to the size of the cable and the adhesive liquefies.

F1029 A-O

Creation Date: May 2026

NHTSA #26V-079

Transport Canada #2026-054

- g. Continue heating the second sleeve on all sides, working from one end to the other.
 - h. Confirm a continuous ring of adhesive can be seen around the circumference of the second sleeve at both ends.
 - i. Position the third sleeve on the upper cable and overlap the top of the second sleeve by 3/4 inch (19 mm).
 - j. Activate the third sleeve and inspect for a continuous ring of sealant at both ends.
39. Cover the heat shrink joint with convolute tubing. If extra convolute tubing is required, use 4/0 Red Slit Convolute (48-25360-022) for 4/0 cables and CONDUIT-NYL, 19MM, FLEX (48-25360-019) for 2/0 cables.
40. Apply red electrical tape to the cable and to the convolute end to create a seamless transition between the ends of the convolute.
41. Install the 5/8-inch (16-mm) routing block (23-13805-062) on the frame bolt for the isolated stud bracket with the threads on the outside of the frame.
42. Install the upper and lower cable clamps on the isolator frame bracket. To prevent cables (A) from rubbing, secure any cables routed on the outside the cable clamps (B), using butterfly cable ties (C). See Fig. [Fig. 34](#).

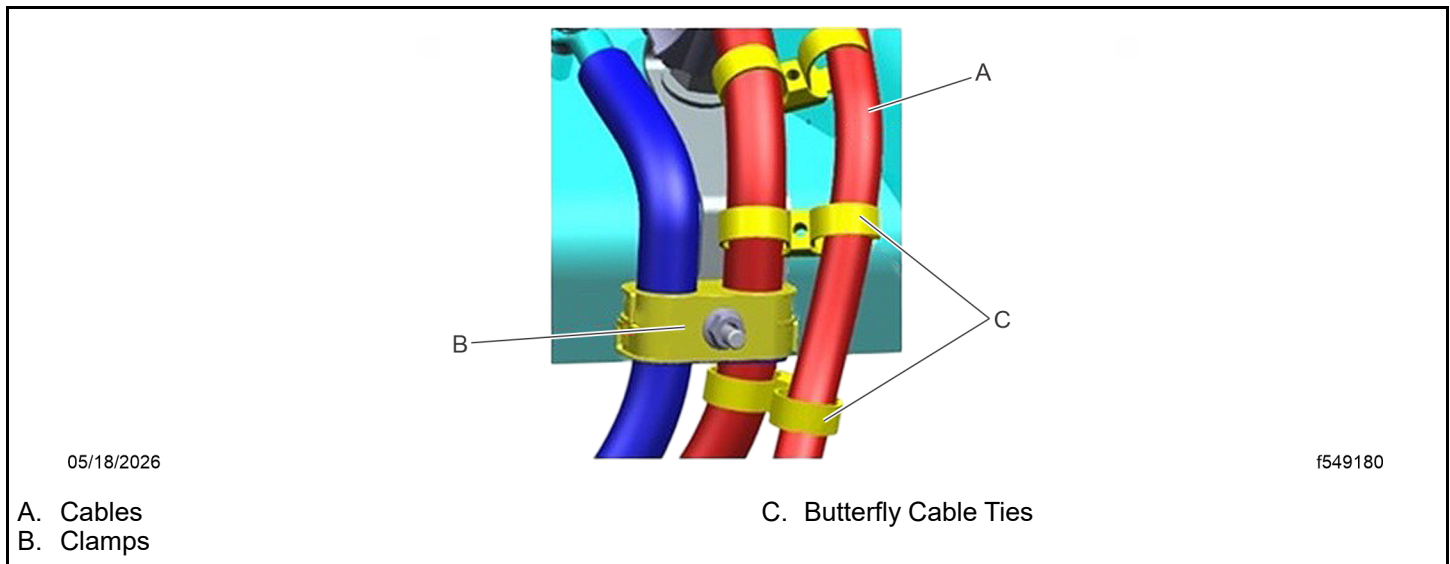

Fig 34, Butterfly Cable Ties Around the Cable Clamps

43. Secure the cables with a Heavy Duty (HD) cable tie (23-13476-000) along the path where positive power cables are routed together.
44. Use butterfly cable ties (TYCDCT110HIR) to route positive cables next to any other cables or anywhere along the path where cables must be separated.
- IMPORTANT: Ensure no power cables are rubbing, or close to rubbing, the frame or engine components.
45. If removed, install the splash shield behind the front tire. For detailed instructions, see Group 88 of the *47X, 48X and 49X Workshop Manual*.
46. Install the negative cable connections at the batteries.

F1029 A-O

Creation Date: May 2026

NHTSA #26V-079

Transport Canada #2026-054

47. Clean a spot on the base label (Form WAR259) and attach a campaign completion sticker for F1029 (Form WAR260).

F1029 A-O

Creation Date: May 2026

NHTSA #26V-079

Transport Canada #2026-054

Group D Work Instructions

1. Check the base label (Form WAR259) for a completion sticker for F1029 (Form WAR260), indicating this work has been done. The base label is usually located on the passenger-side door, about 12 inches (30 cm) below the door latch. If a completion sticker is present, no work is needed. If a completion sticker is not present, proceed to the next step.
2. Park the vehicle on a level surface and set the parking brake. Chock the rear tires.
3. Turn the steer tires to the right to make the isolated stud accessible. Shut down the engine.
4. Open the hood.
5. Locate the isolated positive (+) battery stud mounted on the frame behind the front wheel. See Fig. [Fig. 35](#).

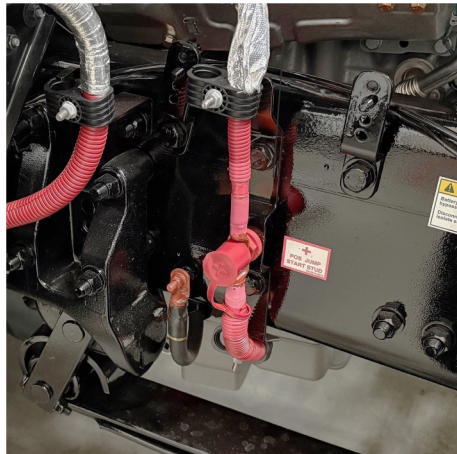

05/17/2026

f549174

Fig 35, Isolated Battery Junction with Jump-Start Post

6. Remove the negative (-) cable connection(s) from the batteries.
7. If required for access, remove the splash shield from behind the front tire. For detailed instructions, see Group 88 of the *47X, 48X and 49X Workshop Manual*.
8. Remove the jump-start post or nut that secures the battery cable(s) to the isolated stud.
9. Remove the clamp(s) that secure the positive battery cables to the clipping point above the frame rail.
10. Remove the clamp(s) and ties that secure the positive battery cable routed between the isolated stud and the starter.
11. Remove the nut that secures the positive battery cables to the starter.
12. Remove the cable that connects the isolated stud to the starter.
13. Remove the bolts that secure the isolated stud bracket to the frame.
14. Remove the isolated stud from the frame bracket.
15. Install the lower isolator bracket frame bolt in position with the head on the inboard side of the frame.

F1029 A-O

Creation Date: May 2026

NHTSA #26V-079

Transport Canada #2026-054

16. Install the upper isolator bracket frame bolt with head on the outside of the frame. Tighten both bolts to 148 lbf·ft (200 N·m).
17. Remove the top bolt from the frame mounted routing and clipping bracket located in front of the isolated stud bracket.
18. Install the new jump-start cable bracket (12-25410-000) on the clipping bracket frame bolt, followed by the washer. Position the assembly in the frame hole. Hand-tighten the fasteners to keep the bracket in position.
19. Remove the ring terminal from the positive cable that is routed to the cab.
 - a. Note how the cable is secured and remove any cable ties, tape, or convolute as needed to uncover at least 6 inches of the cable.
 - b. Remove the original heat shrink. To do so, heat it, score it, and continue to heat it until the score splits and the adhesive softens. See Fig. [Fig. 36](#).

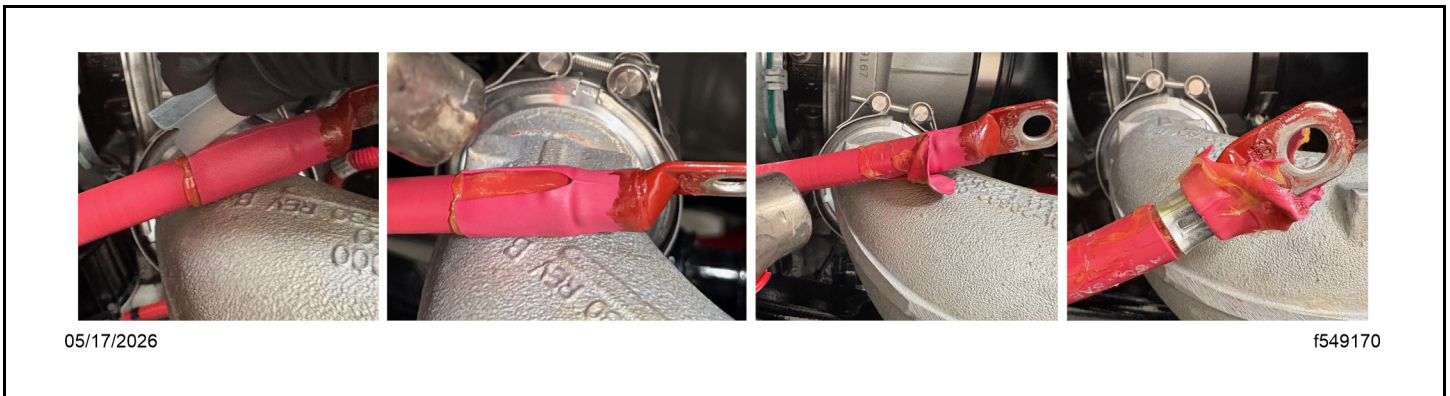

Fig 36, Heat Shrink Removal

- c. Cut the cable just above the ring terminal.
- d. Remove the cable insulation equal to half the butt connector length without damaging the wire strands. See Fig. [Fig. 37](#).

F1029 A-O

Creation Date: May 2026

NHTSA #26V-079

Transport Canada #2026-054



Fig 37, Removing the Insulation

e. Straighten any bent strands of the conductor.

NOTE: To ensure proper crimp force is applied to the terminal, the cable cuts must be square and the number of damaged or lost strands must be minimized.

20. Inspect the conductor for evidence of corrosion. Is corrosion present on the newly exposed conductor?

NOTE: The cable must be replaced if cutting back the corrosion causes the cable to become too short for the butt terminal to be supported by the routing clamp above the frame rail.

a. **YES** → Cut off about 1 inch (25mm) of cable. Repeat steps 19d through 19e to remove the cable insulation. Evaluate the condition of the conductor.

b. **NO** → Go to step 21.

F1029 A-O

Creation Date: May 2026

NHTSA #26V-079

Transport Canada #2026-054

21. Crimp the butt connector terminal (PHM 8 2980) on the cable routed to the cab. See Fig. [Fig. 38](#).

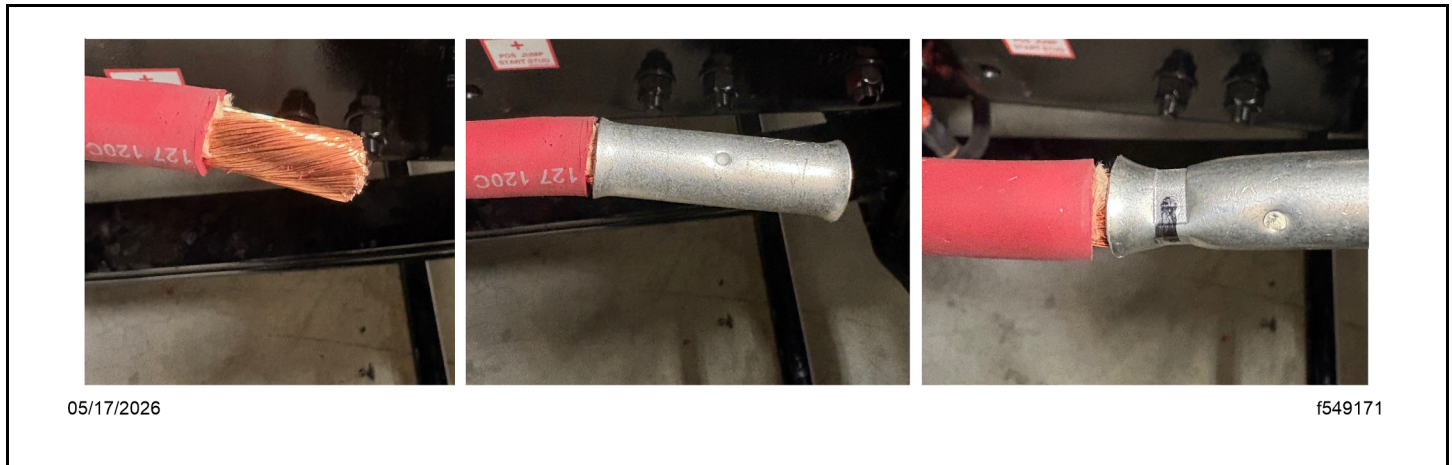

Fig 38, Installing and Crimping the Terminal

- a. Fully seat the conductor in the terminal.
 - b. Adjust the crimping tool to the correct cable size.
 - c. Position the crimping tool approximately 5/16 inch (8mm) from the open end of the barrel. Crimp the terminal.
- NOTE:** To prevent the cable strands from entering the heat shrink over time, all the cable strands must be inserted into the terminal. If the cable strands are outside the barrel, wind them around the conductor in the gap between the cable insulation and the terminal. Apply electrical tape over the gap to prevent them from contacting the heat shrink layer.
22. Determine the length of the new jump-start cable (A66-12311-046).
- a. Compare the old starter cable to the new jump-start cable.
 - b. Remove the tape securing the convolute cover to access the cable.
 - c. Hold the jump-start cable up to the mounting hole on the support bracket.
 - d. Feed the cable under the frame following the path of the other cable(s) to the starter. Mark the cable where it passes the base of the positive post on the starter.
23. Adjust the length of the new jump-start cable. Replace the starter-end terminal.
- a. Remove the tape securing the convolute cover on the cable, if present.
 - b. Cut the cable squarely at the length determined in step 22.
 - c. Position the 4/0 diameter heat shrink sleeve (66-47062-000) on the cable.
 - d. Remove a minimum of 1.2 inch (32mm) of the cable insulation without damaging the wire strands.
 - e. Straighten any bent strands of the conductor.
 - f. Fully seat the conductor in the terminal (23-13773-004).
 - g. Position the new terminal according to the orientation drawing. See Fig. [Fig. 39](#).

F1029 A-O

Creation Date: May 2026

NHTSA #26V-079

Transport Canada #2026-054

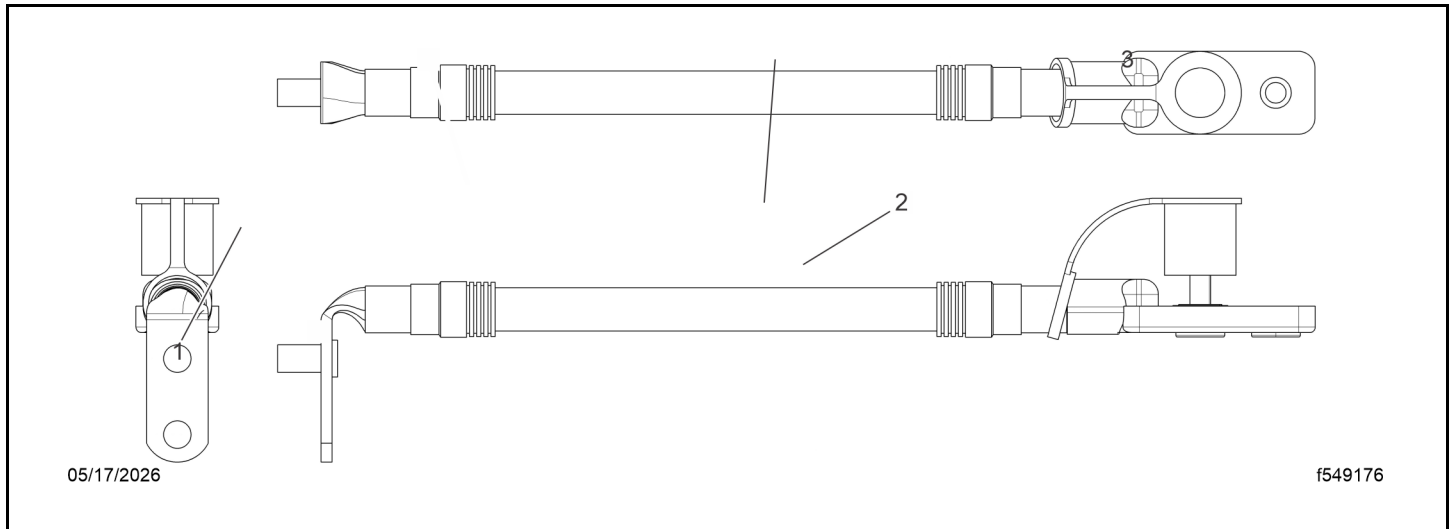

Fig 39, Jump-Start Cable Orientation

- h. Adjust the crimping tool to the correct cable size.
- i. Position the crimping tool approximately 3/8 inch (9mm) from the open end of the barrel and crimp the terminal.

NOTE: If the new jump-start cable terminal does not fit over the conductor easily, deburr the inside diameter of the barrel opening.

NOTE: If the strands of the conductor are too frayed to fit into the terminal barrel, use a small cable tie to make two wraps around the conductor near the end of the insulation. Tighten the tie and push it towards the end of the conductor to compact the strands. Stop with enough remaining conductor to start the terminal, push it on, and remove the tie.

- 24. Apply heat shrink to the cable.
 - a. Slide the heat shrink into position on the terminal.
 - b. Activate the heat shrink sleeve by heating it evenly at one end until it adapts to the size of the terminal and the adhesive liquefies. Continue heating the sleeve on all sides, working from one end to the other.
 - c. Confirm a continuous ring of adhesive can be seen around the circumference of the sleeve at both ends. See Fig. [Fig. 40](#).

F1029 A-O

Creation Date: May 2026

NHTSA #26V-079

Transport Canada #2026-054

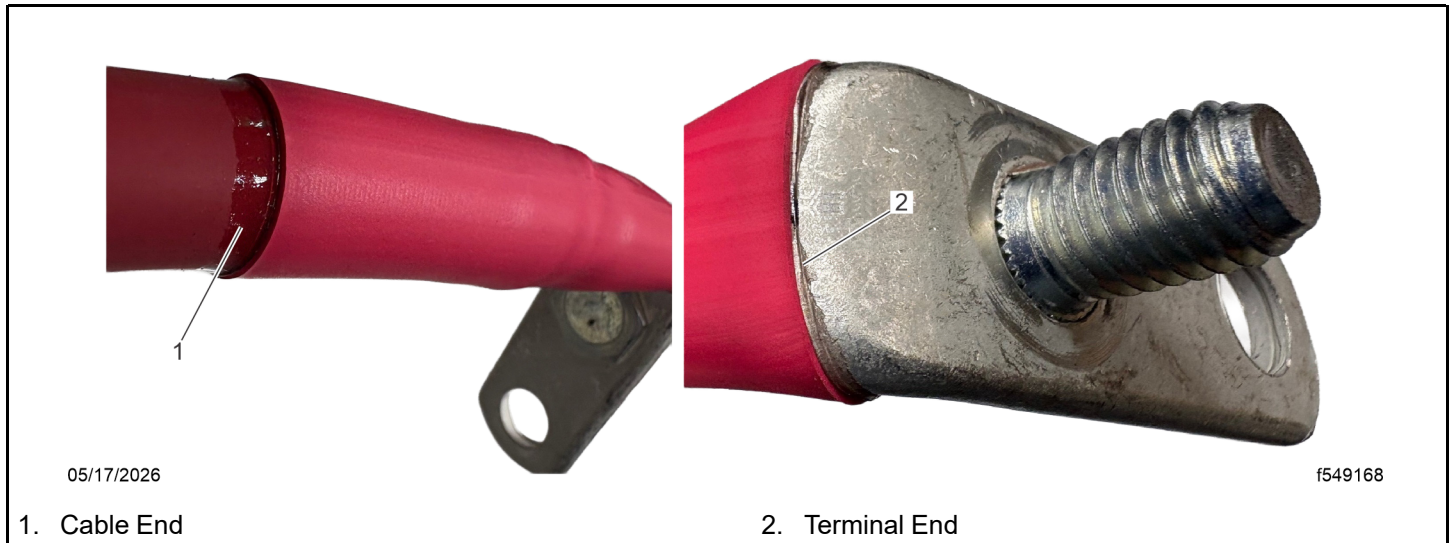

Fig 40, Continuous Adhesive Seal at Cable and Terminal Ends

- d. Install the convolute cover by applying red electrical tape to cover the transition from the heat shrink to the convolute cover. See Fig. [Fig. 41](#).

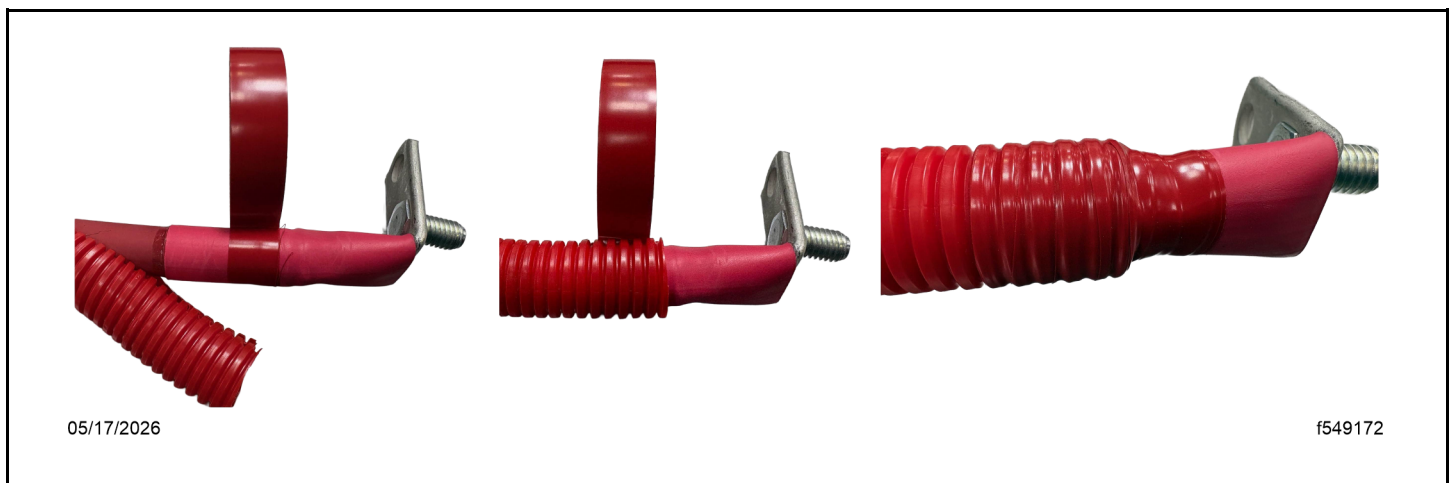

Fig 41, Installing the Convolute Cover

25. Install the new starter cable (A06-78035-065) on the positive terminal of the starter.
26. Install the jump-start cable on the starter. Tighten 19 lbf-ft (26 N·m).
27. Apply dielectric red enamel paint to the exposed surfaces of the cable ends at the starter.

F1029 A-O

Creation Date: May 2026

NHTSA #26V-079

Transport Canada #2026-054

28. Install the 5/8-inch (16-mm) tie block (23-13805-062) on the bottom isolator bracket frame bolt so the cable routing can be set passing by it. See Fig. [Fig. 42](#).

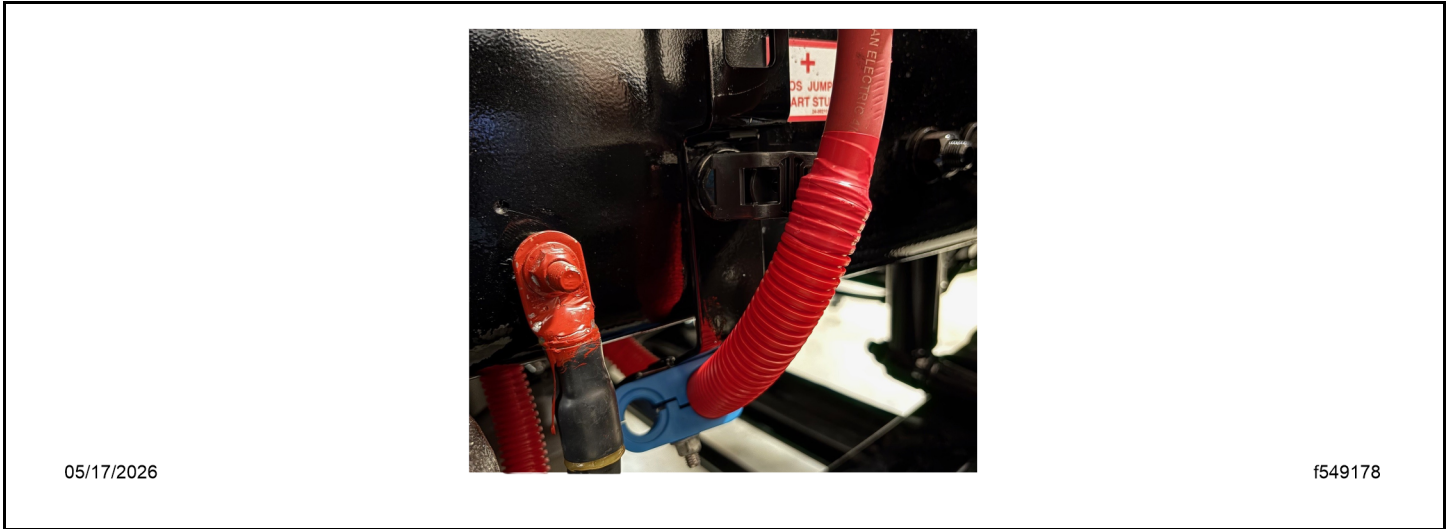

Fig 42, Routing Over the Tie Block

29. Route the starter and jump-start cables next to the other heavy positive cable(s) from the starter to the lower frame rail support bracket. See Fig. [Fig. 43](#).

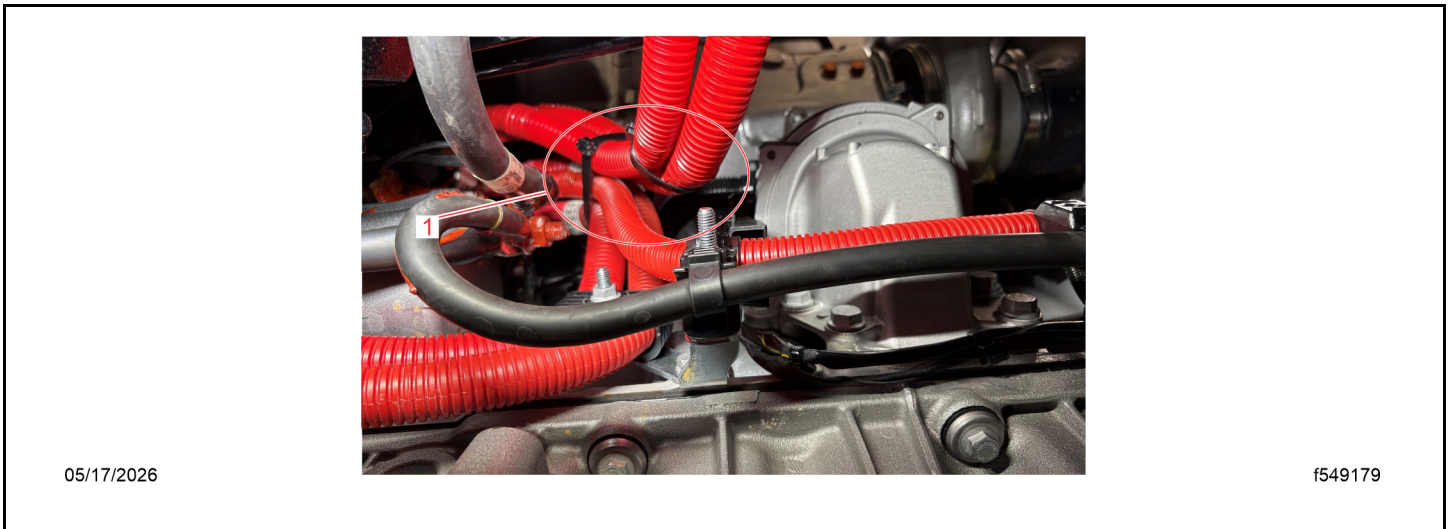

Fig 43, Securing the Cables

F1029 A-O

Creation Date: May 2026

NHTSA #26V-079

Transport Canada #2026-054

1. Secured Cables
30. Use the lower routing clamp to support the 4/0 positive starter cable as it routes under the frame. Route the jump-start cable beside it.
31. Route the jump-start cable to the support bracket and the bolt (N910105 008016), cable, washer (23-10900-038), and nut (23-12612-008). Hand-tighten the fasteners. See Fig. [Fig. 44](#).



Fig 44, Jump-Start Cable Support Bracket

32. Remove the 5/8-inch (16-mm) tie block and tighten the frame bolts that secure the isolator bracket to the frame rail 148 lbf·ft (200 N·m).
33. If required, apply touch-up paint to the frame bolts.
34. Install the 5/8 inch tie block (23-13805-062) on the bottom of the isolator bracket frame bolt.

F1029 A-O

Creation Date: May 2026

NHTSA #26V-079

Transport Canada #2026-054

35. Determine the ideal length for the new starter cable between the starter and butt connector. Cut the cable. See Fig. [Fig. 45](#).

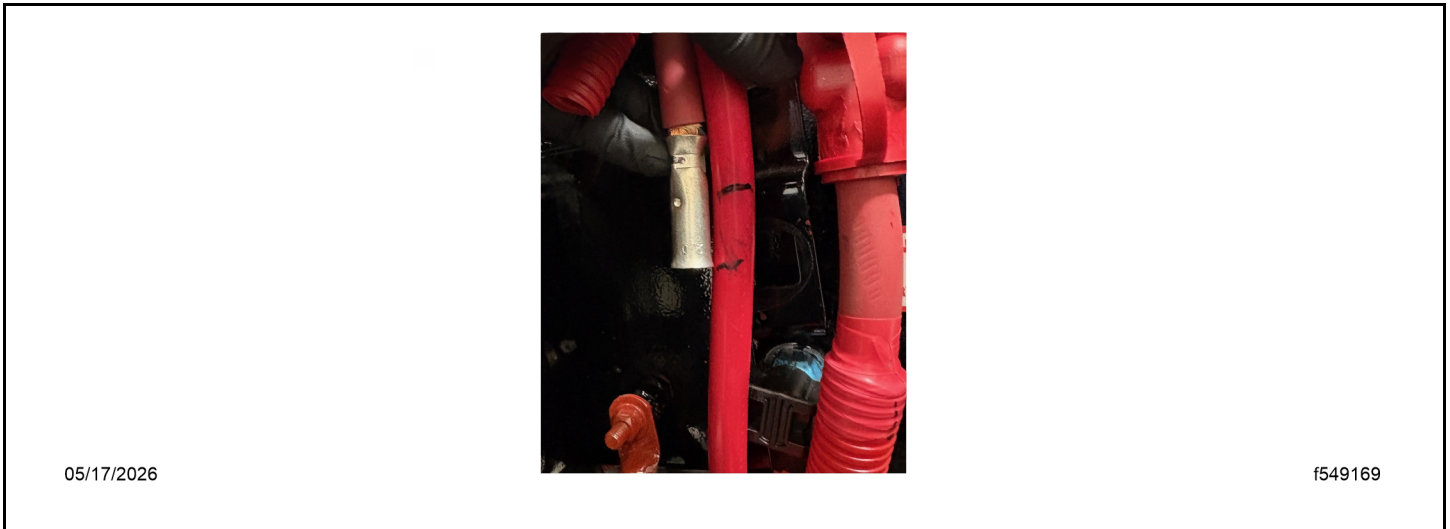

Fig 45, Determining the Starter Cable Length

36. Position three pieces of heat shrink tubing (66-47062-000) on the starter cable with one on the upper cable and two on the lower cable.
- NOTE:** Position the heat shrink tube to allow enough room to complete the butt crimp process without damaging it. If the heat shrink is damaged and splits during the heating process, the terminal must be replaced to ensure the connection is watertight.
37. Crimp the butt connector.
- Remove the cable insulation equal to half the butt connector length without damaging the wire strands.
 - Straighten any bent conductor strands.
 - Fully seat the conductor in the terminal.
 - Adjust the crimping tool to the correct cable size.
 - Crimp the terminal.

F1029 A-O

Creation Date: May 2026

NHTSA #26V-079

Transport Canada #2026-054

38. Insulate the butt connection with heat shrink sleeves. See Fig. Fig. 46.

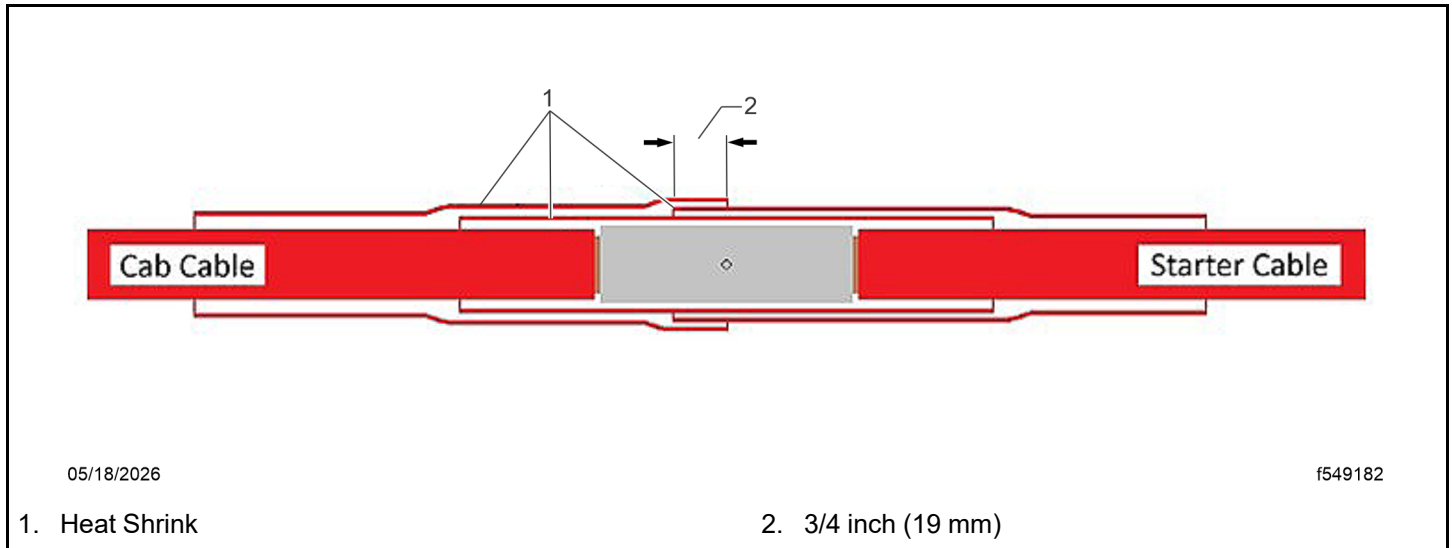

Fig 46, Heat Shrink Insulation

- a. Center the first piece of heat shrink sleeve on the terminal.
 - b. Activate the sleeve by heating it evenly from one end until it adapts to the size of the cable and the adhesive liquefies.
 - c. Continue heating the sleeve on all sides, working from one end to the other.
 - d. Confirm a continuous ring of adhesive can be seen around the circumference of the sleeve at both ends.
 - e. Position the second sleeve on the lower cable and overlap the center of the first sleeve by 3/4 inch (19mm).
 - f. Activate the second sleeve by heating it evenly from one end until it adapts to the size of the cable and the adhesive liquefies.
 - g. Continue heating the second sleeve on all sides, working from one end to the other.
 - h. Confirm a continuous ring of adhesive can be seen around the circumference of the second sleeve at both ends.
 - i. Position the third sleeve on the upper cable and overlap the top of the second sleeve by 3/4 inch (19mm).
 - j. Activate the third sleeve and inspect for a continuous ring of sealant at both ends.
39. Cover the heat shrink joint with convolute tubing. If extra convolute tubing is required, use 4/0 Red Slit Convolute (48-25360-022) for 4/0 cables and CONDUIT-NYL, 19MM, FLEX (48-25360-019) for 2/0 cables.
40. Apply red electrical tape to the cable and to the convolute end to create a seamless transition between the ends of the convolute.

F1029 A-O

Creation Date: May 2026

NHTSA #26V-079

Transport Canada #2026-054

41. Install the upper and lower cable clamps on the isolator frame bracket. To prevent cables (A) from rubbing, secure any cables routed on the outside cable clamps (B) using butterfly cable ties (C) (TYCDCT110HIR). See Fig. Fig. 47.

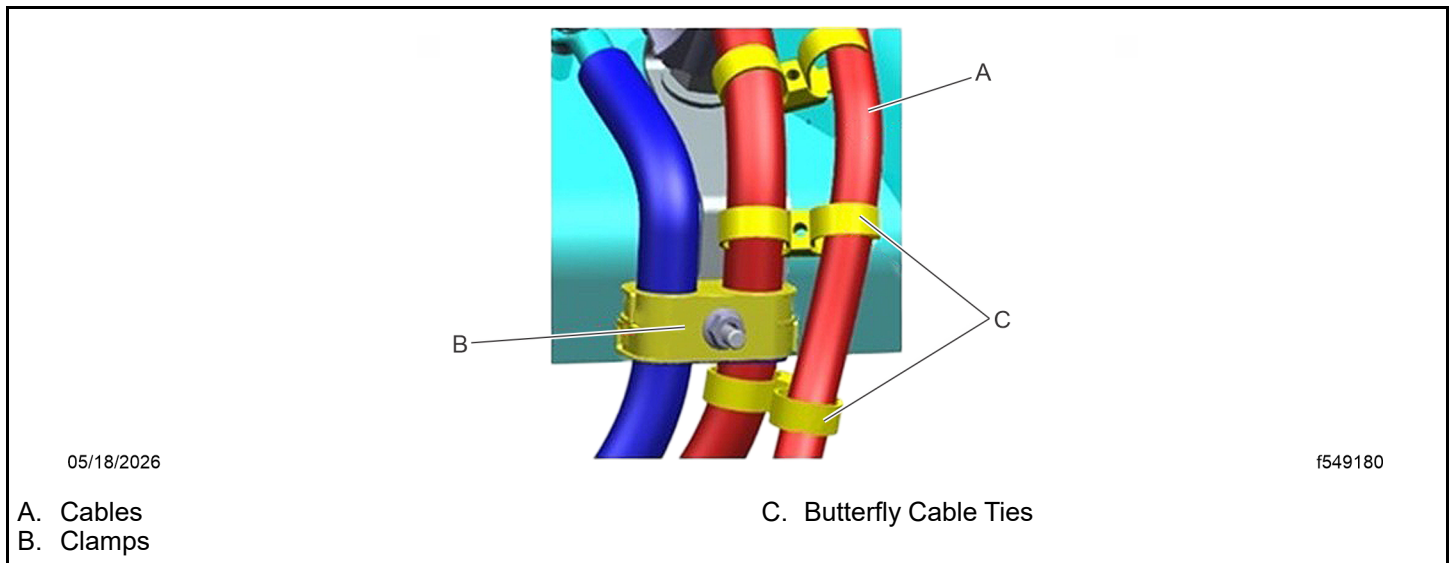

Fig 47, Butterfly Cable Ties Around the Cable Clamps

42. Secure the cables to the 5/8 inch tie block with a Heavy Duty (HD) cable tie (23-13476-000) and other points where positive power cables are routed together.
43. Use butterfly cable ties (TYCDCT110HIR) to route positive cables next to any other cables or anywhere along the path where cables must be separated.
- IMPORTANT: Ensure no power cables are rubbing, or close to rubbing, the frame or engine components.
44. Remove the nut that secures the jump-start cable to the support bracket. Apply medium strength thread locker. Install the nut and tighten 14 lbf·ft (19 N·m).

F1029 A-O

Creation Date: May 2026

NHTSA #26V-079

Transport Canada #2026-054

45. Install the nylon nut (23-13379-001) on the tail of the bolt that secures the jump-start cable to the support bracket (1). Tighten the nut 7 lbf·ft (9.5Nm). See Fig. [Fig. 48](#).



Fig 48, Nylon Nut on Jump-Start Bracket Fastener

1. Nylon Nut
46. If removed, install the splash shield behind the front tire. For detailed instructions, see Group 88 of the *47X, 48X and 49X Workshop Manual*.
47. Install the negative cable connections at the batteries.
48. Clean a spot on the base label (Form WAR259) and attach a campaign completion sticker for F1029 (Form WAR260).

F1029 A-O

Creation Date: May 2026

NHTSA #26V-079

Transport Canada #2026-054

Group E Work Instructions

1. Check the base label (Form WAR259) for a completion sticker for F1029 (Form WAR260), indicating this work has been done. The base label is usually located on the passenger-side door, about 12 inches (30 cm) below the door latch. If a completion sticker is present, no work is needed. If a completion sticker is not present, proceed to the next step.
2. Park the vehicle on a level surface and set the parking brake. Chock the rear tires.
3. Turn the steer wheels to the left side to make the isolated stud accessible. Shut down the engine.
4. Open the hood.
5. Locate the isolated positive (+) battery stud mounted on the frame behind the front wheel. See Fig. [Fig. 49](#).

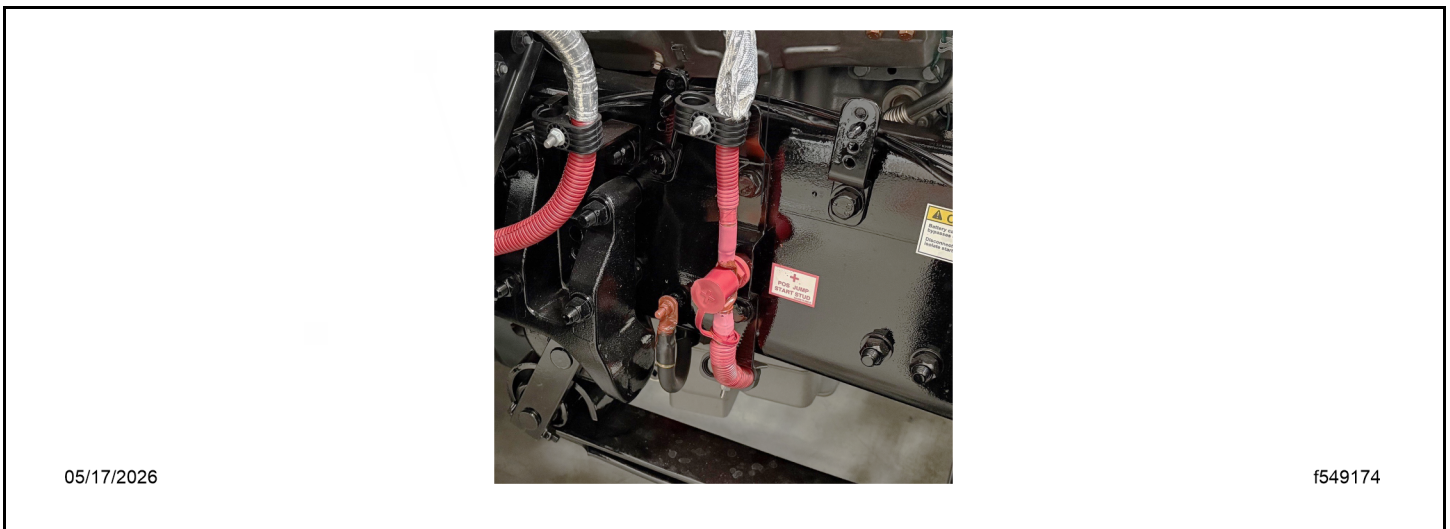

Fig 49, Isolated Battery Junction with Jump-Start Post

6. Remove the negative (-) cable connection(s) from the batteries.
7. If required for access, remove the splash shield from behind the front tire. For detailed instructions, see Group 88 of the *47X, 48X and 49X Workshop Manual*.
8. Remove the jump-start post or nut that secures the battery cable(s) to the isolated stud.
9. Remove the clamp(s) that secure the positive battery cables to the clipping point above the frame rail.
10. Remove the clamp(s) and ties that secure the positive battery cable routed between the isolated stud and the starter.
11. Remove the nut that secures the positive battery cables to the starter.
12. Remove the cable that connects the isolated stud to the starter.
13. Remove the bolts that secure the isolated stud bracket to the frame.
14. Remove the isolated stud from the frame bracket.
15. Install the lower isolator bracket frame bolt in position with the head on the inboard side of the frame.

F1029 A-O

Creation Date: May 2026

NHTSA #26V-079

Transport Canada #2026-054

16. Install the isolator bracket, washer, and nut. Hand-tighten the fasteners to keep the bracket in position.
17. Install the upper isolator bracket bolt with the threads on the inboard side of the frame. Tighten both frame bolts 148 lbf·ft (200 N·m).
18. If required, apply touch-up paint to the frame bolts.
19. Remove the ring terminals from the positive cables that are routed to the cab.
 - a. Note how the cable is secured and remove any cable ties, tape, or convolute as needed to uncover at least 6 inches of the cable.
 - b. Remove the original heat shrink. To do so, heat it, score it, and continue to heat it until the score splits and the adhesive softens. See Fig. [Fig. 50](#).

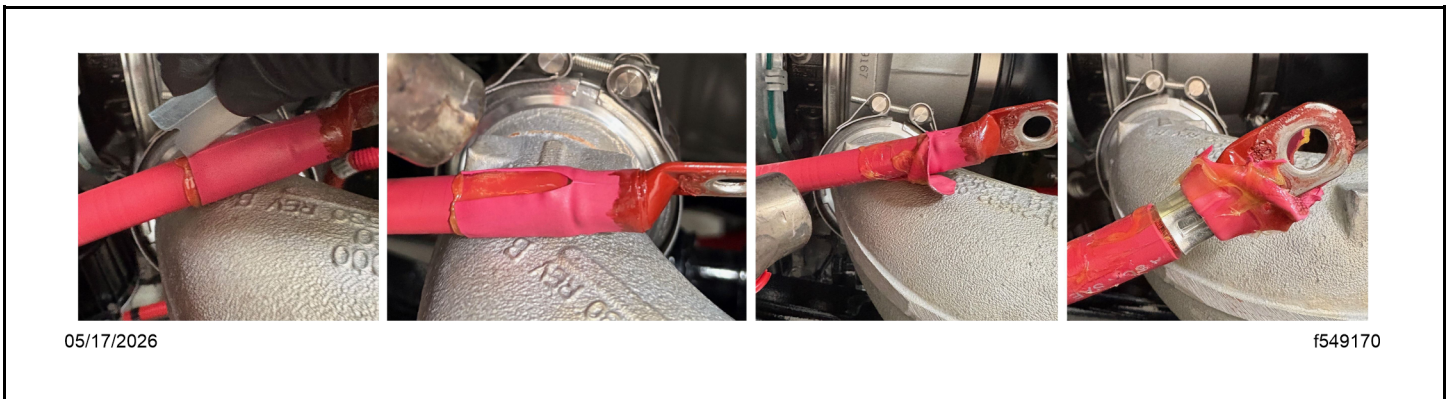

Fig 50, Heat Shrink Removal

- c. Cut the cable just above the ring terminal.
- d. Remove the cable insulation equal to half the butt connector length without damaging the wire strands. See Fig. [Fig. 51](#).

F1029 A-O

Creation Date: May 2026

NHTSA #26V-079

Transport Canada #2026-054



Fig 51, Removing the Insulation

- e. Straighten any bent strands of the conductor.
- f. Repeat steps 19a through 19e to remove the ring terminal on the second cable.

NOTE: To ensure proper crimp force is applied to the terminal, the cable cuts must be square and the number of damaged or lost strands must be minimized.

20. Inspect the conductors for evidence of corrosion. Is corrosion present on either of the newly exposed conductors?

NOTE: The cable must be replaced if cutting back the corrosion causes the cable to become too short for the butt terminal to be supported by the routing clamp above the frame rail.

- a. **YES** → Cut off about 1 inch (25 mm) of cable. Repeat steps 19d through 19e to remove the cable insulation. Evaluate the condition of the conductor.
- b. **NO** → Go to step 21.

F1029 A-O

Creation Date: May 2026

NHTSA #26V-079

Transport Canada #2026-054

21. Crimp the butt connector terminals (PHM 8 2960 and PHM 8 2980) on the cables routed to the cab. See Fig. [Fig. 52](#).

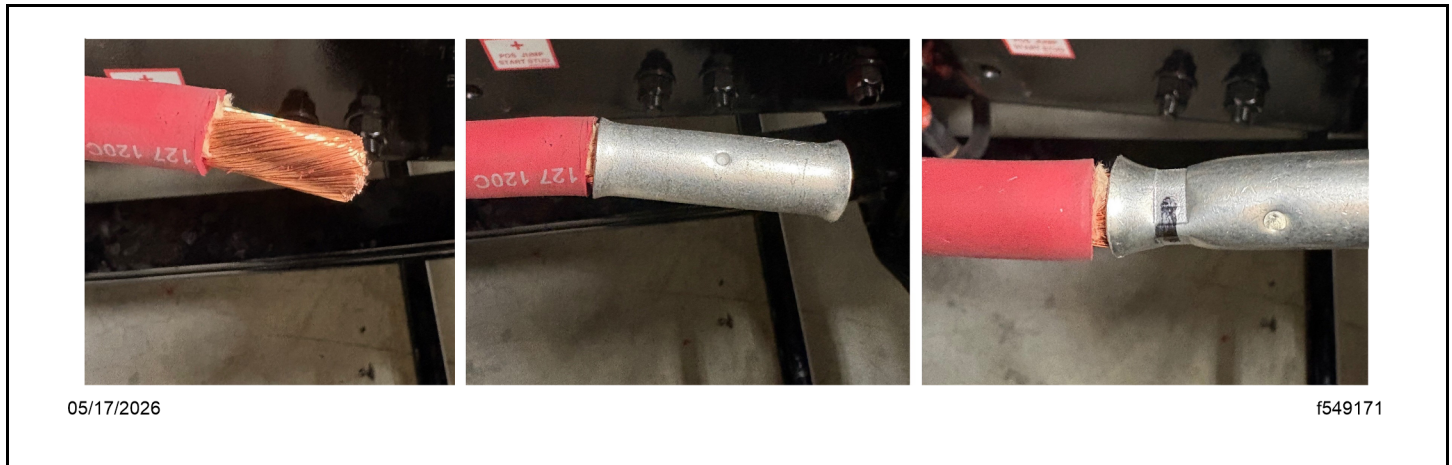

Fig 52, Installing and Crimping the Terminal

- a. Fully seat the conductor in the terminal.
- b. Adjust the crimping tool to the correct cable size.
- c. Position the crimping tool approximately 5/16 inch (8 mm) from the open end of the barrel. Crimp the terminal.
- d. Repeat steps 21a through 21c to crimp the second cable.

NOTE: To prevent the cable strands from entering the heat shrink over time, all the cable strands must be inserted into the terminal. If the cable strands are outside the barrel, wind them around the conductor in the gap between the cable insulation and the terminal. Apply electrical tape over the gap to prevent them from contacting the heat shrink layer.

22. Install the convolute cover (48-25360-019) on the new auxiliary Battery Cable Access (BCA) cable (A06-35801-060).
- a. Apply red electrical tape to cover the transition from the heat shrink to the convolute on the starter end of the cable.
 - b. From the starter end of the cable, add two tape rings at approximately 6 to 8 inch (150 to 200 mm) increments to secure the convolute to the cable. Leave the remaining cover loose until the butt connection has been made and sealed.
23. Install the new starter cable (A06-78035-065) on the positive terminal on the starter.
24. Install the auxiliary BCA cable assembly on the starter. Tighten 19 lbf·ft (26 N·m).
25. Apply dielectric red enamel paint to the exposed surfaces of the cable ends at the starter.
26. Install the 5/8-inch (16-mm) tie block (23-13805-062) on the bottom isolator bracket frame bolt.

F1029 A-O

Creation Date: May 2026

NHTSA #26V-079

Transport Canada #2026-054

27. Route the starter and auxiliary BCA cables next to the other heavy positive cable(s) from the starter to the lower frame rail support bracket. See Fig. **Fig. 53**.

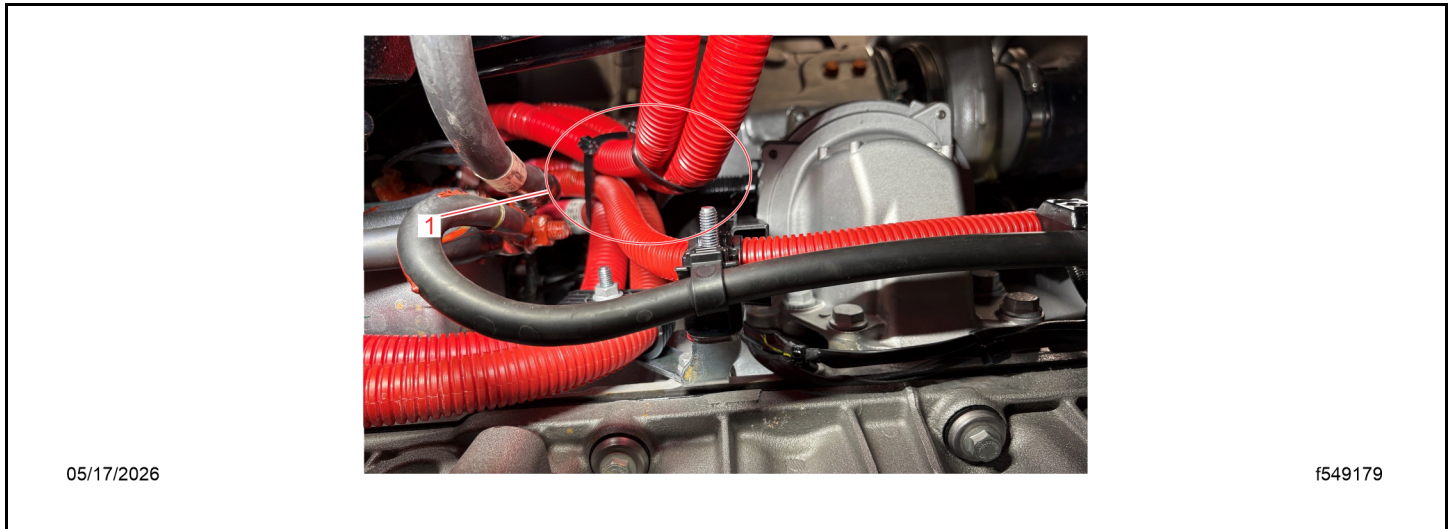

Fig 53, Securing the Cables

1. Secured Cables
28. Use the lower routing clamp to support the 4/0 positive starter cable as it routes under the frame. Route the auxiliary BCA cable next to it.

F1029 A-O

Creation Date: May 2026

NHTSA #26V-079

Transport Canada #2026-054

29. Determine the ideal length for the new auxiliary BCA and starter cables between the starter and butt connector. Cut the cables. See Fig. [Fig. 54](#).

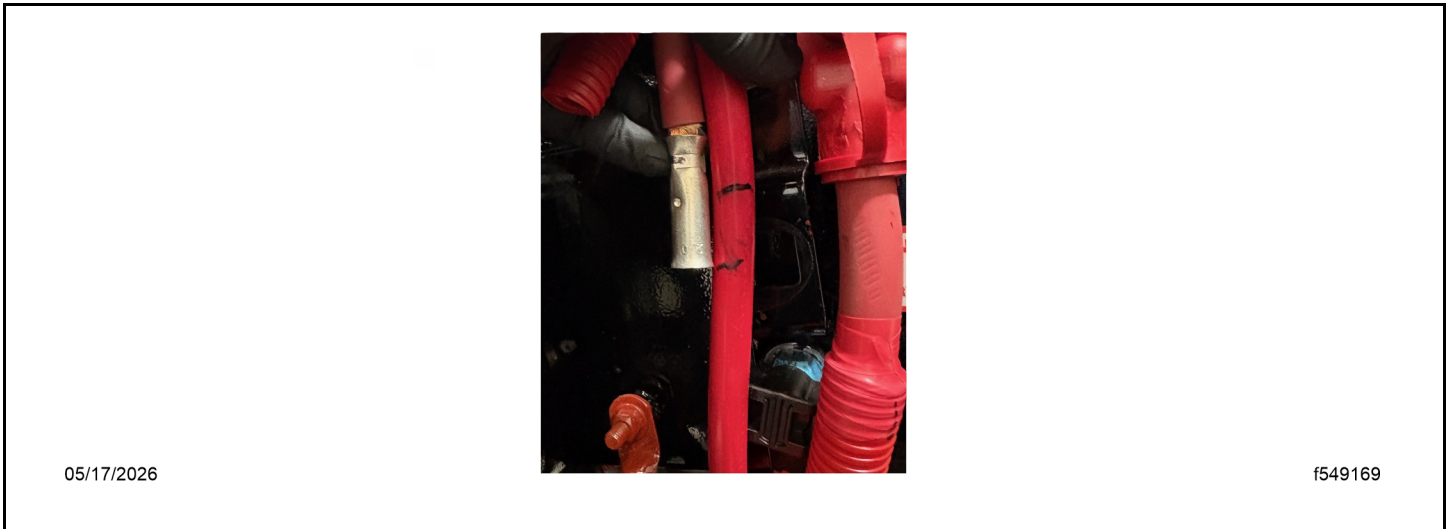

Fig 54, Determining the BCA Cable Length

30. Position three pieces of heat shrink tubing (66-47062-001) on the auxiliary BCA cable with one on the upper cable and two on the lower cable. Position three pieces of heat shrink tubing (66-47062-000) on the starter cable with one on each upper cable and two on each lower cable.

NOTE: To ensure a watertight connection, position the heat shrink tube to allow enough room to complete the butt crimp process without damaging it. If the heat shrink is damaged or splits during heating, replace the terminal.

31. Crimp the butt connectors.
- Remove the cable insulation equal to half the butt connector length without damaging the wire strands.
 - Straighten any bent conductor strands.
 - Fully seat the conductor in the terminal.
 - Adjust the crimping tool to the correct cable size.
 - Crimp the terminal.
 - Repeat steps 31a through 31e to crimp the second cable.

F1029 A-O

Creation Date: May 2026

NHTSA #26V-079

Transport Canada #2026-054

32. Insulate the butt connections with heat shrink sleeves. See Fig. Fig. 55.

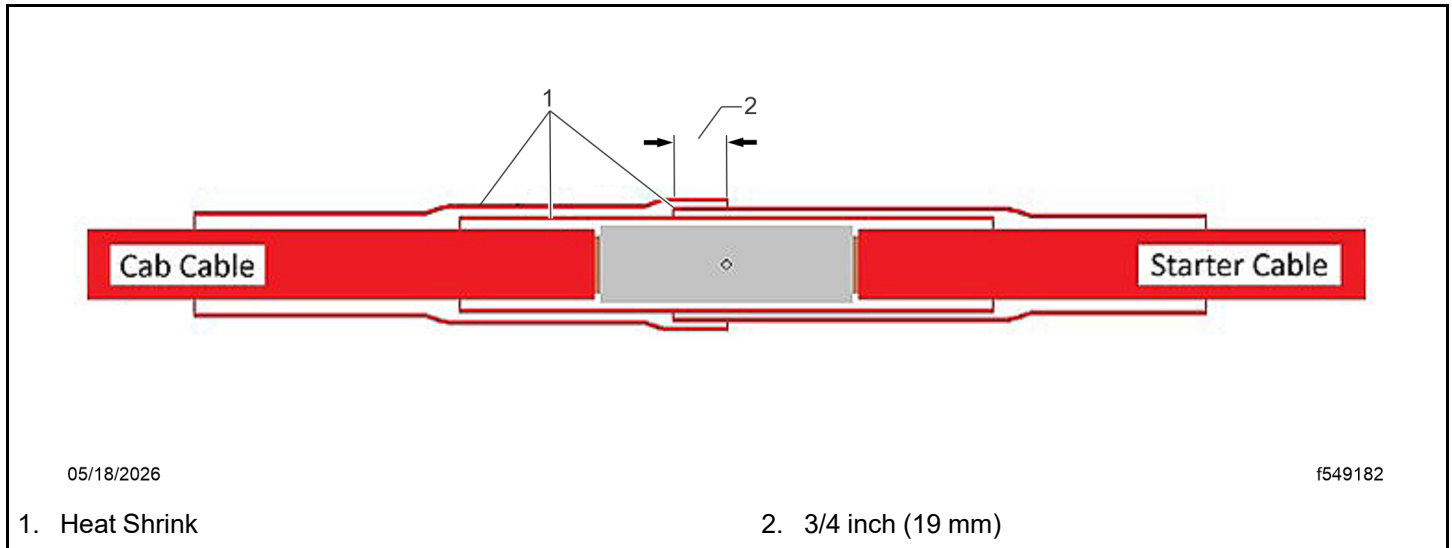

Fig 55, Heat Shrink Insulation

- a. Center the first piece of heat shrink sleeve on the terminal.
 - b. Activate the sleeve by heating it evenly from one end until it adapts to the size of the cable and the adhesive liquefies.
 - c. Continue heating the sleeve on all sides, working from one end to the other.
 - d. Confirm a continuous ring of adhesive can be seen around the circumference of the sleeve at both ends.
 - e. Position the second sleeve on the lower cable and overlap the center of the first sleeve by 3/4 inch (19 mm).
 - f. Activate the second sleeve by heating it evenly from one end until it adapts to the size of the cable and the adhesive liquefies.
 - g. Continue heating the second sleeve on all sides, working from one end to the other.
 - h. Confirm a continuous ring of adhesive can be seen around the circumference of the second sleeve at both ends.
 - i. Position the third sleeve on the upper cable and overlap the top of the second sleeve by 3/4 inch (19 mm).
 - j. Activate the third sleeve and inspect for a continuous ring of sealant at both ends.
 - k. Repeat steps 32a through 32k to insulate the second cable.
33. Cover the heat shrink joints with convolute tubing. If extra convolute tubing is required, use 4/0 Red Slit Convolute (48-25360-022) for 4/0 cables, and CONDUIT-NYL, 19MM, FLEX (48-25360-019) for 2/0 cables.
34. Apply red electrical tape to the cable and to the convolute end to create a seamless transition between the ends of the convolute.

F1029 A-O

Creation Date: May 2026

NHTSA #26V-079

Transport Canada #2026-054

35. Install the upper and lower cable clamps on the isolator frame bracket. To prevent cables (A) from rubbing, secure any cables routed on the outside cable clamps (B) using butterfly cable ties (C) (TYCDCT110HIR). See Fig. [Fig. 56](#).

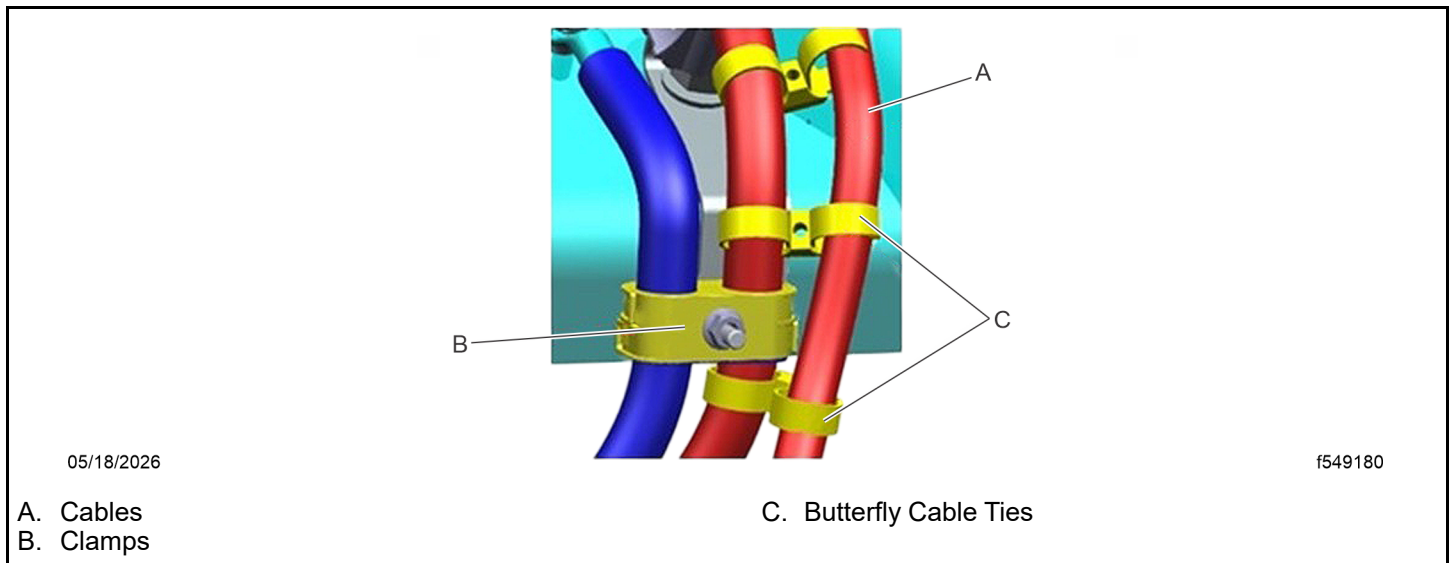

Fig 56, Butterfly Cable Ties Around the Cable Clamps

36. Secure the cables to the 5/8-inch (16-mm) tie block with a Heavy Duty (HD) cable tie (23-13476-000) and other points where positive power cables are routed together.
37. Use butterfly cable ties (TYCDCT110HIR) to secure the auxiliary BCA cable to the starter cable at three points (A) to prevent the cable from rubbing on nearby items. See Fig. [Fig. 57](#).

F1029 A-O

Creation Date: May 2026

NHTSA #26V-079

Transport Canada #2026-054

IMPORTANT: Ensure no power cables are rubbing, or close to rubbing, the frame or engine components.

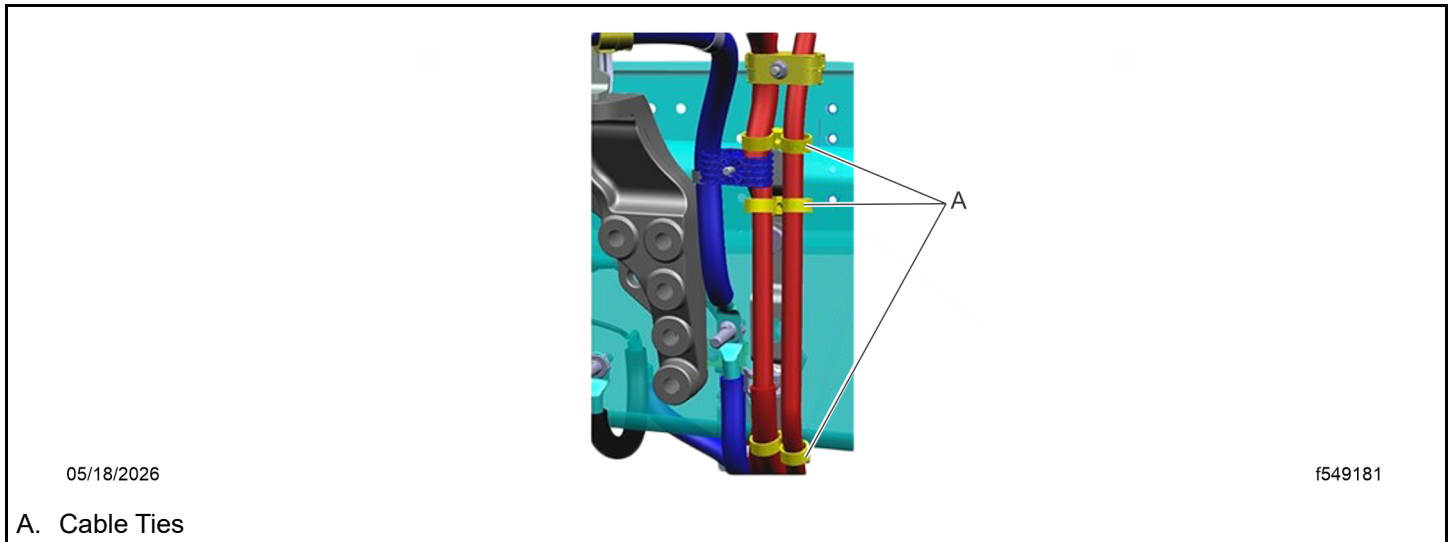

Fig 57, Butterfly Cable Tie Locations

38. If removed, install the splash shield behind the front tire. For detailed instructions, see Group 88 of the *47X, 48X and 49X Workshop Manual*.
39. Install the negative cable connections at the batteries.
40. Clean a spot on the base label (Form WAR259) and attach a campaign completion sticker for F1029 (Form WAR260).

F1029 A-O

Creation Date: May 2026

NHTSA #26V-079

Transport Canada #2026-054

Group F Work Instructions

1. Check the base label (Form WAR259) for a completion sticker for F1029 (Form WAR260), indicating this work has been done. The base label is usually located on the passenger-side door, about 12 inches (30 cm) below the door latch. If a completion sticker is present, no work is needed. If a completion sticker is not present, proceed to the next step.
2. Park the vehicle on a level surface and set the parking brake. Chock the rear tires.
3. Turn the steer wheels to the left side to make the isolated stud accessible. Shut down the engine.
4. Open the hood.
5. Locate the isolated positive (+) battery stud mounted on the frame behind the front wheel. See Fig. [Fig. 58](#).

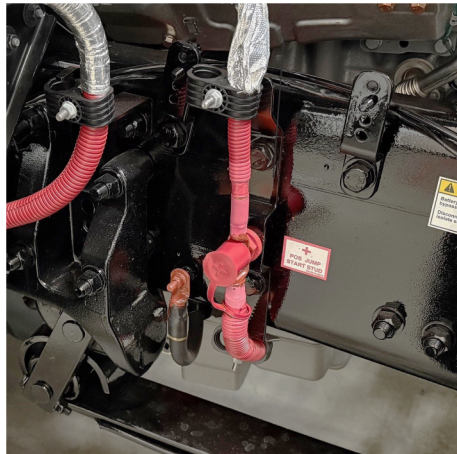

05/17/2026

f549174

Fig 58, Isolated Battery Junction with Jump-Start Post

6. Remove the negative (-) cable connection(s) from the batteries.
7. If required for access, remove the splash shield from behind the front tire. For detailed instructions, see Group 88 of the *47X, 48X and 49X Workshop Manual*.
8. Remove the jump-start post or nut that secures the battery cable(s) to the isolated stud.
9. Remove the clamp(s) that secure the positive battery cables to the clipping point above the frame rail.
10. Remove the clamp(s) and ties that secure the positive battery cable routed between the isolated stud and the starter.
11. Remove the nut that secures the positive battery cables to the starter.
12. Remove the cable that connects the isolated stud to the starter.
13. Remove the bolts that secure the isolated stud bracket to the frame.
14. Remove the isolated stud from the frame bracket.
15. Fit the lower isolator bracket frame bolt in position with the head on the inboard side of the frame.

F1029 A-O

Creation Date: May 2026

NHTSA #26V-079

Transport Canada #2026-054

16. Fit the isolator bracket, washer, and nut. Hand-tighten the fasteners to keep the bracket in position.
17. Fit the jump-start cable bracket (12-25410-000) on the upper frame bolt followed by the washer. Position the bracket in the frame hole and tighten to keep it in position.
18. Remove the ring terminals from the positive cables that are routed to the cab.
 - a. Note how the cable is secured and remove any cable ties, tape, or convolute as needed to uncover at least 6 inches of the cable.
 - b. Remove the original heat shrink. To do so, heat it, score it, and continue to heat it until the score splits and the adhesive softens. See Fig. [Fig. 59](#).

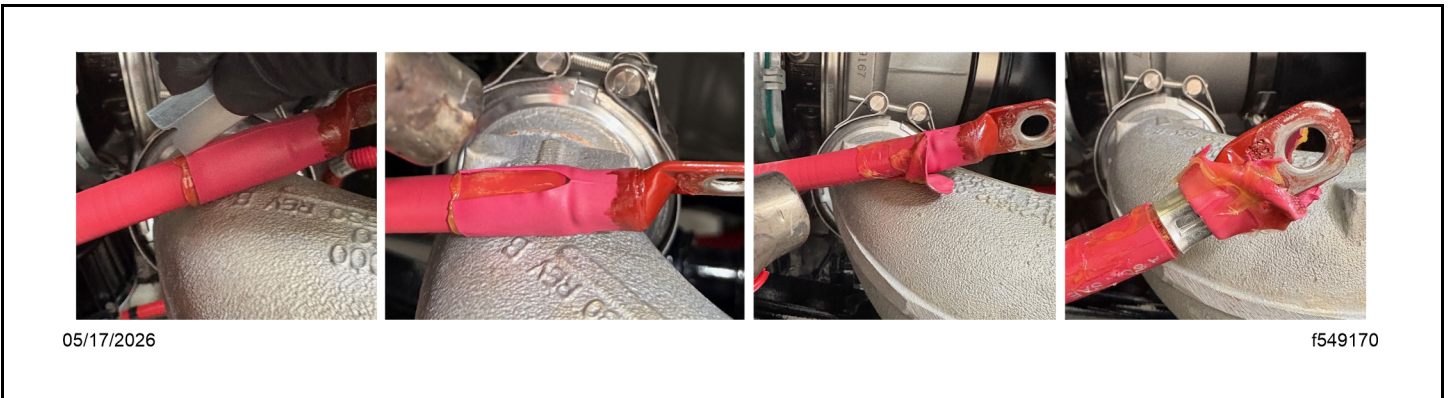

Fig 59, Heat Shrink Removal

- c. Cut the cable just above the ring terminal.
- d. Remove the cable insulation equal to half the butt connector length without damaging the wire strands. See Fig. [Fig. 60](#).

F1029 A-O

Creation Date: May 2026

NHTSA #26V-079

Transport Canada #2026-054



Fig 60, Removing the Insulation

- e. Straighten any bent strands of the conductor.
- f. Repeat steps 18a through 18e to remove the ring terminal from the second cable.

NOTE: To ensure proper crimp force is applied to the terminal, the cable cuts must be square and the number of damaged or lost strands must be minimized.

19. Inspect the conductors for evidence of corrosion. Is corrosion present on either of the newly exposed conductors?

NOTE: The cable must be replaced if cutting back the corrosion causes the cable to become too short for the butt terminal to be supported by the routing clamp above the frame rail.

- a. **YES** → Cut off about 1 inch (25 mm) of cable. Repeat steps 18d through 18e to remove the cable insulation. Evaluate the condition of the conductor.
- b. **NO** → Go to step 20.

F1029 A-O

Creation Date: May 2026

NHTSA #26V-079

Transport Canada #2026-054

20. Crimp the butt connector terminals (PHM 8 2960 and PHM 8 2980) on the cables routed to the cab. See Fig. [Fig. 61](#).

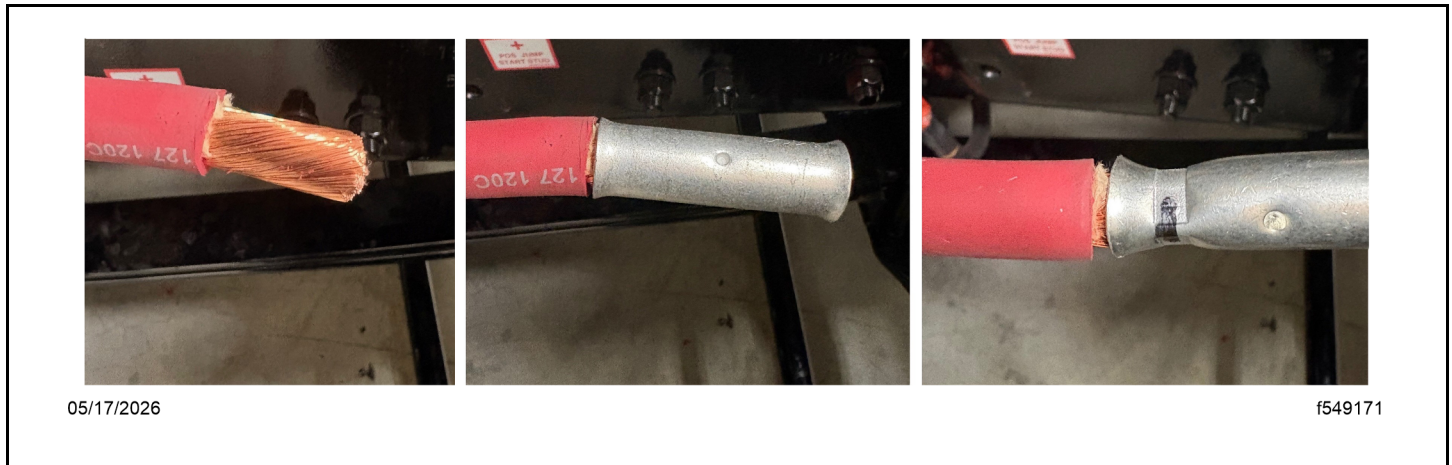

Fig 61, Installing and Crimping the Terminal

- a. Fully seat the conductor in the terminal.
- b. Adjust the crimping tool to the correct cable size.
- c. Position the crimping tool approximately 5/16 inch (8 mm) from the open end of the barrel. Crimp the terminal.
- d. Repeat steps 20a through 20c to crimp the second cable.

NOTE: To prevent the cable strands from entering the heat shrink over time, all the cable strands must be inserted into the terminal. If the cable strands are outside the barrel, wind them around the conductor in the gap between the cable insulation and the terminal. Apply electrical tape over the gap to prevent them from contacting the heat shrink layer.

21. Determine the length of the new jump-start cable (A66-12311-046).
- a. Compare the old starter cable to the new jump-start cable.
 - b. Remove the tape securing the convolute cover to access the cable.
 - c. Hold the jump-start cable up to the mounting hole on the support bracket.
 - d. Feed the cable under the frame following the path of the other cable(s) to the starter. Mark the cable where it passes the base of the positive post on the starter.
22. Adjust the length of the new jump-start cable. Replace the starter-end terminal.
- a. Remove the tape securing the convolute cover on the cable, if present.
 - b. Cut the cable squarely at the length determined in step 21.
 - c. Position the 4/0 diameter heat shrink sleeve (66-47062-000) on the cable.
 - d. Remove a minimum of 1.2 inch (32 mm) of the cable insulation without damaging the wire strands.
 - e. Straighten any bent strands of the conductor.
 - f. Fully seat the conductor in the terminal (23-13773-004).

F1029 A-O

Creation Date: May 2026

NHTSA #26V-079

Transport Canada #2026-054

- g. Position the new terminal according to the orientation drawing. See Fig. [Fig. 62](#).

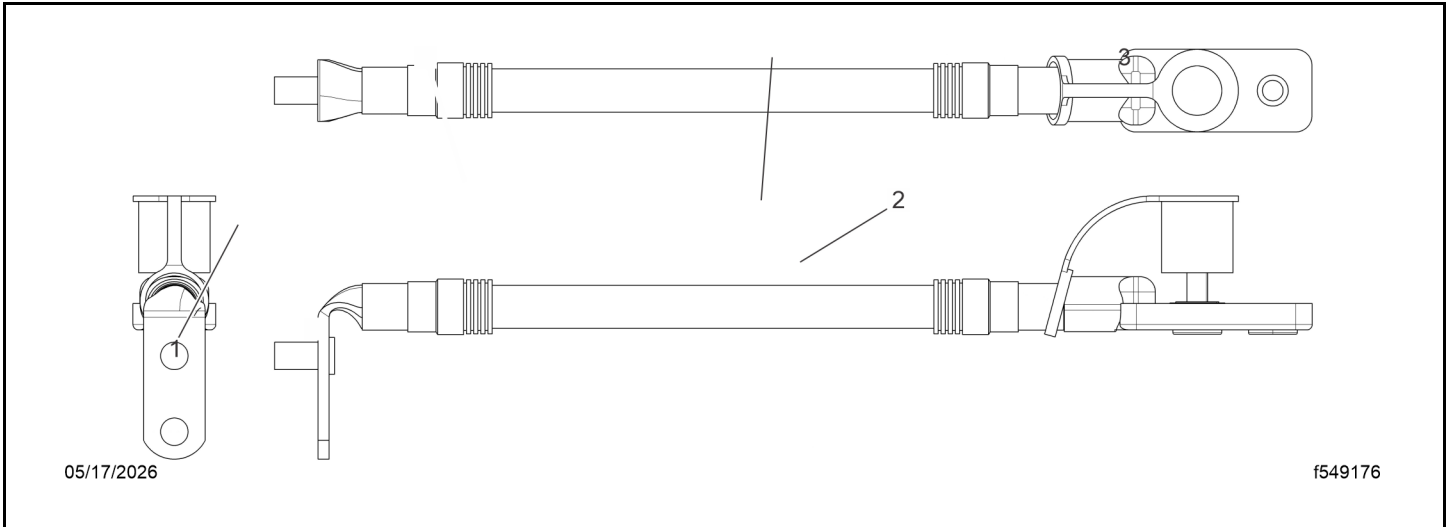

Fig 62, Jump-Start Cable Orientation

- h. Adjust the crimping tool to the correct cable size.
i. Position the crimping tool approximately 3/8 inch (9 mm) from the open end of the barrel and crimp the terminal.

NOTE: If the new jump-start cable terminal does not fit over the conductor easily, deburr the inside diameter of the barrel opening.

NOTE: If the strands of the conductor are too frayed to fit into the terminal barrel, use a small cable tie to make two wraps around the conductor near the end of the insulation. Tighten the tie and push it towards the end of the conductor to compact the strands. Stop with enough remaining conductor to start the terminal, push it on, and remove the tie.

23. Apply heat shrink to the cable.
- Slide the heat shrink into position on the terminal.
 - Activate the heat shrink sleeve by heating it evenly at one end until it adapts to the size of the terminal and the adhesive liquefies. Continue heating the sleeve on all sides, working from one end to the other.
 - Confirm a continuous ring of adhesive can be seen around the circumference of the sleeve at both ends. See Fig. [Fig. 63](#).

F1029 A-O

Creation Date: May 2026

NHTSA #26V-079

Transport Canada #2026-054

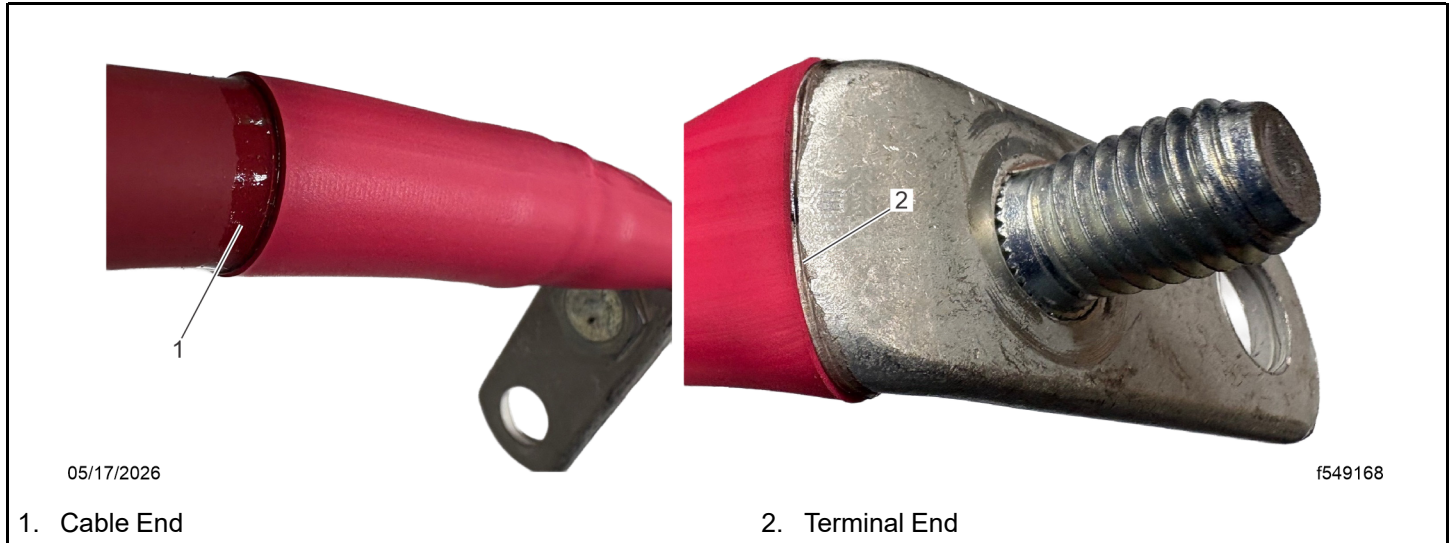

Fig 63, Continuous Adhesive Seal at Cable and Terminal Ends

- d. Install the convolute cover by applying red electrical tape to cover the transition from the heat shrink to the convolute cover. See Fig. [Fig. 64](#).

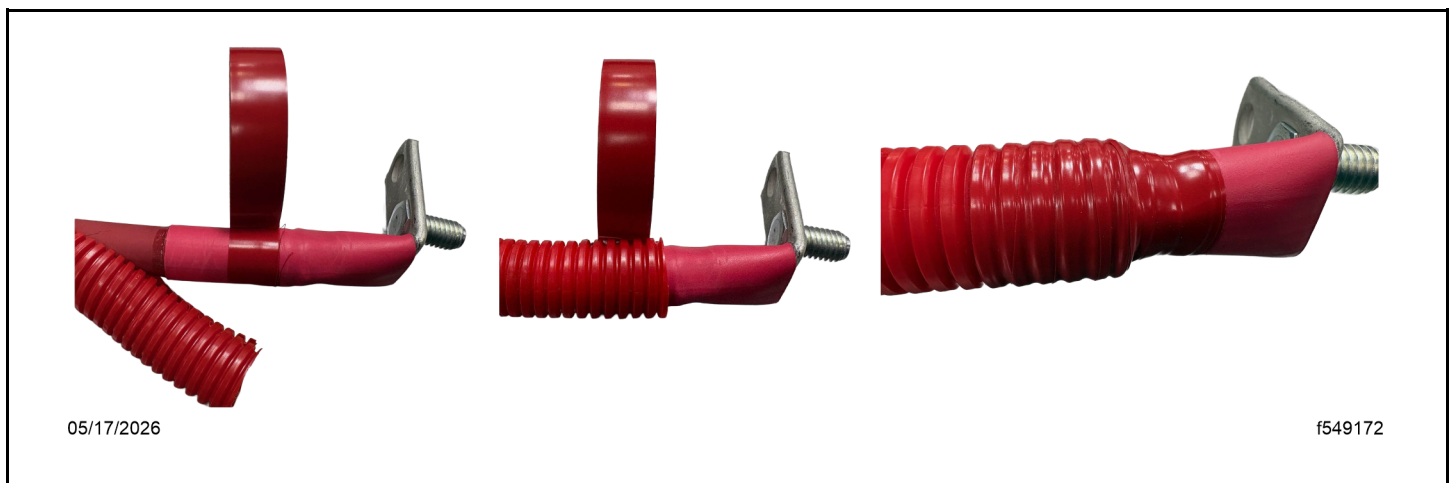

Fig 64, Installing the Convolute Cover

24. Install the convolute cover (48-25360-019) on the new auxiliary Battery Cable Access (BCA) cable (A06-35801-060).
 - a. Apply red electrical tape to cover the transition from the heat shrink to the convolute on the starter end of the cable.
 - b. From the starter end of the cable, add two tape rings at approximately 6 to 8 inch (150 to 200 mm) increments to secure the convolute to the cable. Leave the remaining cover loose until the butt connection has been made and sealed.

F1029 A-O

Creation Date: May 2026

NHTSA #26V-079

Transport Canada #2026-054

25. Assemble the new auxiliary BCA and the jump-start cable. See Fig. [Fig. 65](#).



Fig 65, Assembled Jump-Start and BCA Cables

- a. Position the auxiliary BCA cable end on the extra post of the jump-start cable to fit with the other cables on the starter. Ensure the two cables do not cross between the starter and the under-frame routing bracket.
 - b. Install the nut (23-09596-050) and washer (23-10900-050). Tighten the fasteners 19 lbf·ft (26 N·m).
26. Fit the new starter cable (A06-78035-065) on the positive terminal on the starter.
27. Install the jump-start auxiliary BCA cable assembly on the starter. Tighten 19 lbf·ft (26 N·m).
28. Apply dielectric red enamel paint to the exposed surfaces of the cable ends at the starter.

F1029 A-O

Creation Date: May 2026

NHTSA #26V-079

Transport Canada #2026-054

29. Install the 5/8-inch (16-mm) tie block (23-13805-062) on the bottom isolator bracket frame bolt so the cable routing can be set passing by it. See Fig. [Fig. 66](#).

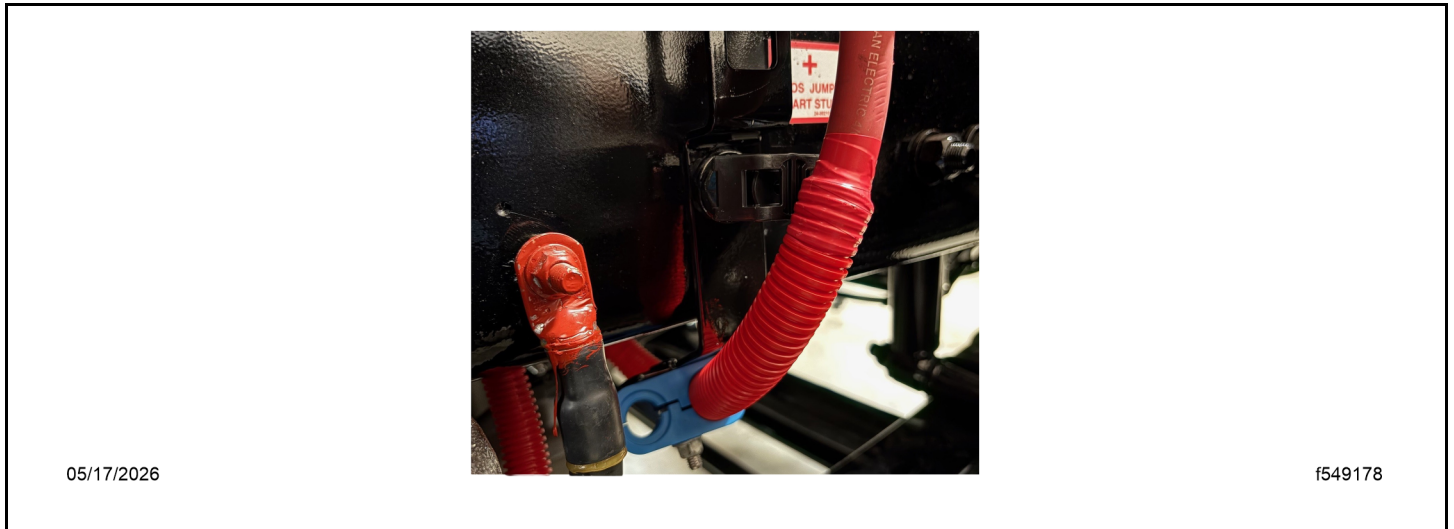

Fig 66, Routing Over the Tie Block

30. Route the starter and jump-start auxiliary BCA cables next to the other heavy positive cable(s) from the starter to the lower frame rail support bracket. See Fig. [Fig. 67](#).

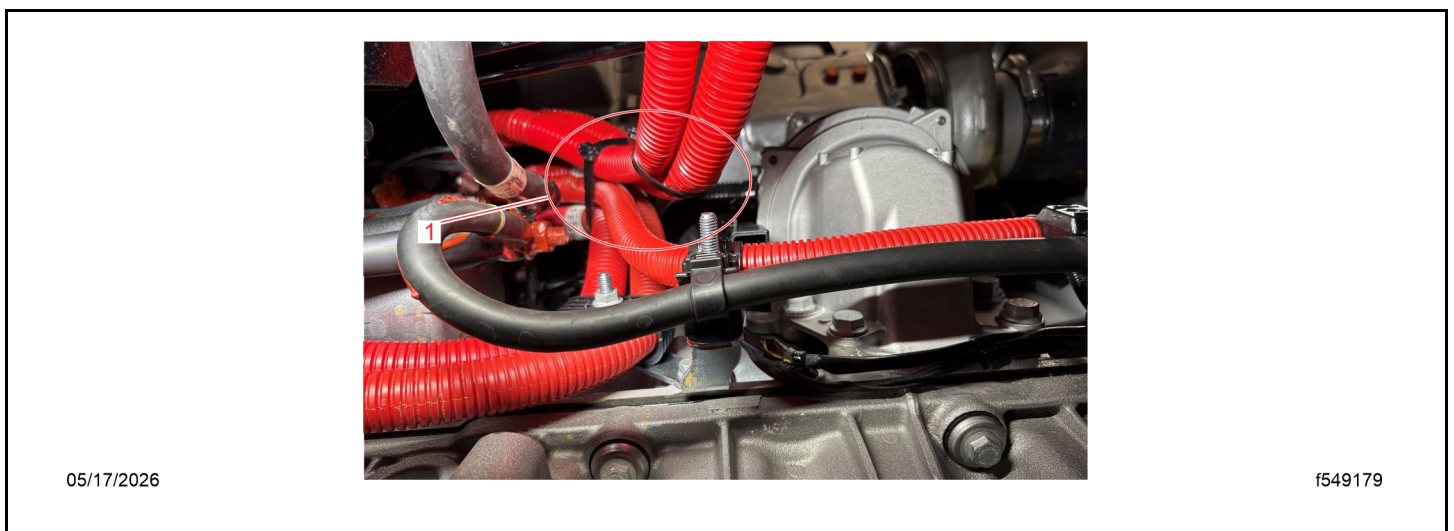

Fig 67, Securing the Cables

F1029 A-O

Creation Date: May 2026

NHTSA #26V-079

Transport Canada #2026-054

1. Secured Cables

31.

NOTE: If the cables routing under the frame include a ground cable utilizing the one of the two routing clamp holes, route the 4/0 cables in the original clamps and butterfly the BCA cable along the path using butterfly ties (TYCDCT110HIR).

Use the lower routing clamp to support the 4/0 positive starter cable as it routes under the frame. Route the jump-start cable beside it.

32. Use the lower routing clamp to support the 4/0 positive starter cable as it routes under the frame. Route the jump-start cable next to it.
33. Route the jump-start cable to the support bracket and the bolt (N910105 008016), cable, washer (23-10900-038), and nut (23-12612-008). Hand-tighten the fasteners. See Fig. [Fig. 68](#).



Fig 68, Jump-Start Cable Support Bracket

34. Remove the 5/8 inch tie block and tighten the frame bolts that secure the isolator bracket to the frame rail to 148 lbf·ft (200 N·m).
35. If required, apply touch-up paint to the frame bolts.
36. Install the 5/8 inch tie block (23-13805-062) on the bottom of the isolator bracket frame bolt.

F1029 A-O

Creation Date: May 2026

NHTSA #26V-079

Transport Canada #2026-054

37. Determine the ideal length for the new auxiliary BCA cable and starter cable between the starter and butt connector. Cut the cables. See Fig. [Fig. 69](#).

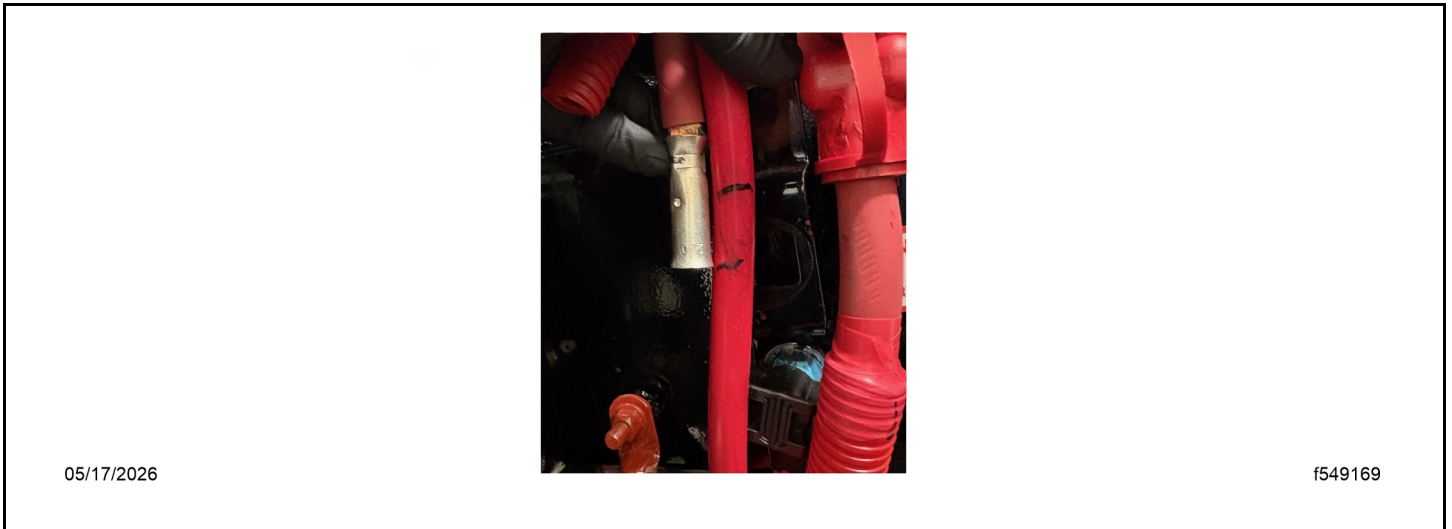

Fig 69, Determining the BCA Cable Length

38. Position three pieces of heat shrink tubing (66-47062-001) on the auxiliary BCA cable, with one on each upper cable and two on each lower cable. Position three pieces of heat shrink tubing (66-47062-000) on the starter cable, with one on each upper cable and two on each lower cable.

NOTE: To ensure a watertight connection, position the heat shrink tube to allow enough room to complete the butt crimp process without damaging it. If the heat shrink is damaged or splits during heating, replace the terminal.

39. Crimp the butt connectors.
- Remove the cable insulation equal to half the butt connector length without damaging the wire strands.
 - Straighten any bent conductor strands.
 - Fully seat the conductor in the terminal.
 - Adjust the crimping tool to the correct cable size.
 - Crimp the terminal.
 - Repeat steps 39a through 39e to crimp the second cable.

F1029 A-O

Creation Date: May 2026

NHTSA #26V-079

Transport Canada #2026-054

40. Insulate the butt connections with heat shrink sleeves. See Fig. Fig. 70.

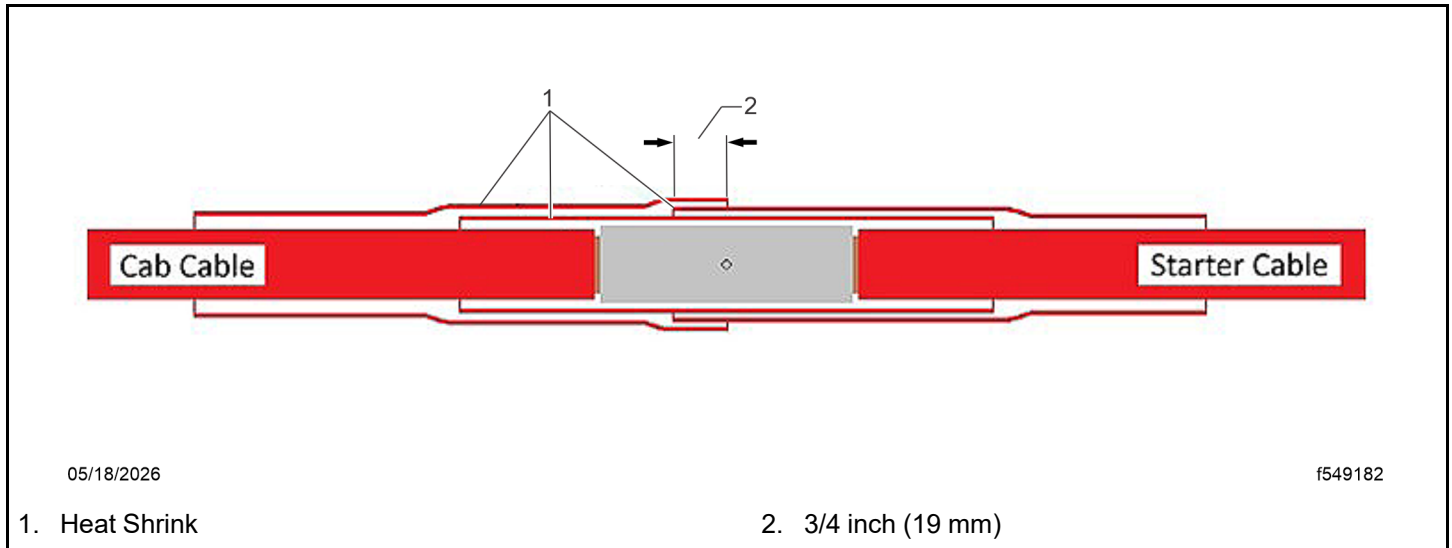

Fig 70, Heat Shrink Insulation

- a. Center the first piece of heat shrink sleeve on the terminal.
 - b. Activate the sleeve by heating it evenly from one end until it adapts to the size of the cable and the adhesive liquefies.
 - c. Continue heating the sleeve on all sides, working from one end to the other.
 - d. Confirm a continuous ring of adhesive can be seen around the circumference of the sleeve at both ends.
 - e. Position the second sleeve on the lower cable and overlap the center of the first sleeve by 3/4 inch (19 mm).
 - f. Activate the second sleeve by heating it evenly from one end until it adapts to the size of the cable and the adhesive liquefies.
 - g. Continue heating the second sleeve on all sides, working from one end to the other.
 - h. Confirm a continuous ring of adhesive can be seen around the circumference of the second sleeve at both ends.
 - i. Position the third sleeve on the upper cable and overlap the top of the second sleeve by 3/4 inch (19 mm).
 - j. Activate the third sleeve and inspect for a continuous ring of sealant at both ends.
 - k. Repeat steps 40a through 40k to insulate the second cable.
41. Cover the heat shrink joints with convolute tubing. If extra convolute tubing is required, use 4/0 Red Slit Convolute (48-25360-022) for 4/0 cables, and CONDUIT-NYL, 19MM, FLEX (48-25360-019) for 2/0 cables.
42. Apply red electrical tape to the cable and to the convolute end to create a seamless transition between the ends of the convolute.

F1029 A-O

Creation Date: May 2026

NHTSA #26V-079

Transport Canada #2026-054

43. Install the upper and lower cable clamps on the isolator frame bracket. To prevent cables (A) from rubbing, secure any cables routed on the outside cable clamps (B) using butterfly cable ties (C) (TYCDCT110HIR). See Fig. [Fig. 71](#).

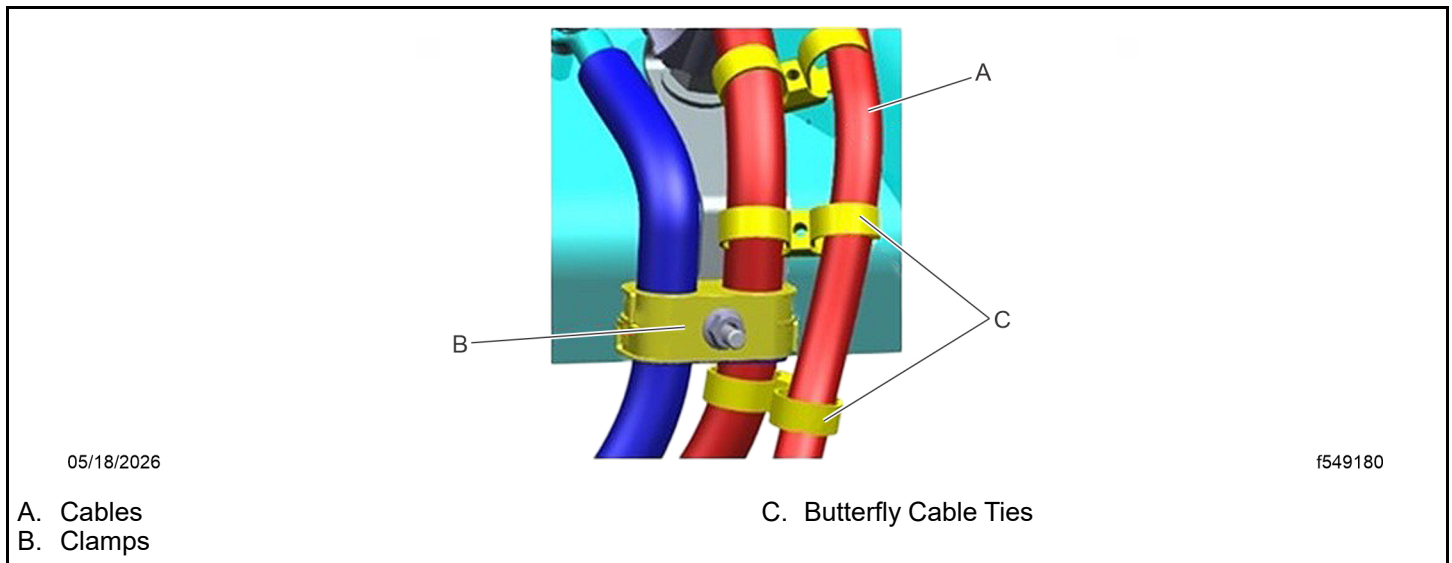

Fig 71, Butterfly Cable Ties Around the Cable Clamps

44. Secure the cables to the 5/8 inch (16 mm) tie block with a Heavy Duty (HD) cable tie (23-13476-000) and other points where positive power cables are routed together.
45. Use butterfly cable ties (TYCDCT110HIR) to route positive cables next to any other cables or anywhere along the path where cables must be separated.
- IMPORTANT: Ensure no power cables are rubbing, or close to rubbing, the frame or engine components.
46. Remove the nut that secures the jump-start cable to the support bracket. Apply medium strength thread locker. Install the nut and tighten 14 lbf·ft (19 N·m).

F1029 A-O

Creation Date: May 2026

NHTSA #26V-079

Transport Canada #2026-054

47. Install the nylon nut (23-13379-001) on the tail of the bolt that secures the jump-start cable to the support bracket (1). Tighten the nut 7 lbf·ft (9.5Nm). See Fig. [Fig. 72](#).



Fig 72, Nylon Nut on Jump-Start Bracket Fastener

1. Nylon Nut
48. If removed, install the splash shield behind the front tire. For detailed instructions, see Group 88 of the *47X, 48X and 49X Workshop Manual*.
49. Install the negative cable connections at the batteries.
50. Clean a spot on the base label (Form WAR259) and attach a campaign completion sticker for F1029 (Form WAR260).

F1029 A-O

Creation Date: May 2026

NHTSA #26V-079

Transport Canada #2026-054

Group G Work Instructions

1. Check the base label (Form WAR259) for a completion sticker for F1029 (Form WAR260), indicating this work has been done. The base label is usually located on the passenger-side door, about 12 inches (30 cm) below the door latch. If a completion sticker is present, no work is needed. If a completion sticker is not present, proceed to the next step.
2. Park the vehicle on a level surface and set the parking brake. Chock the rear tires.
3. Turn the steer tires to the right to make the isolated stud accessible. Shut down the engine.
4. Open the hood.
5. Locate the isolated positive (+) battery stud mounted on the frame behind the front wheel. See Fig. [Fig. 73](#).

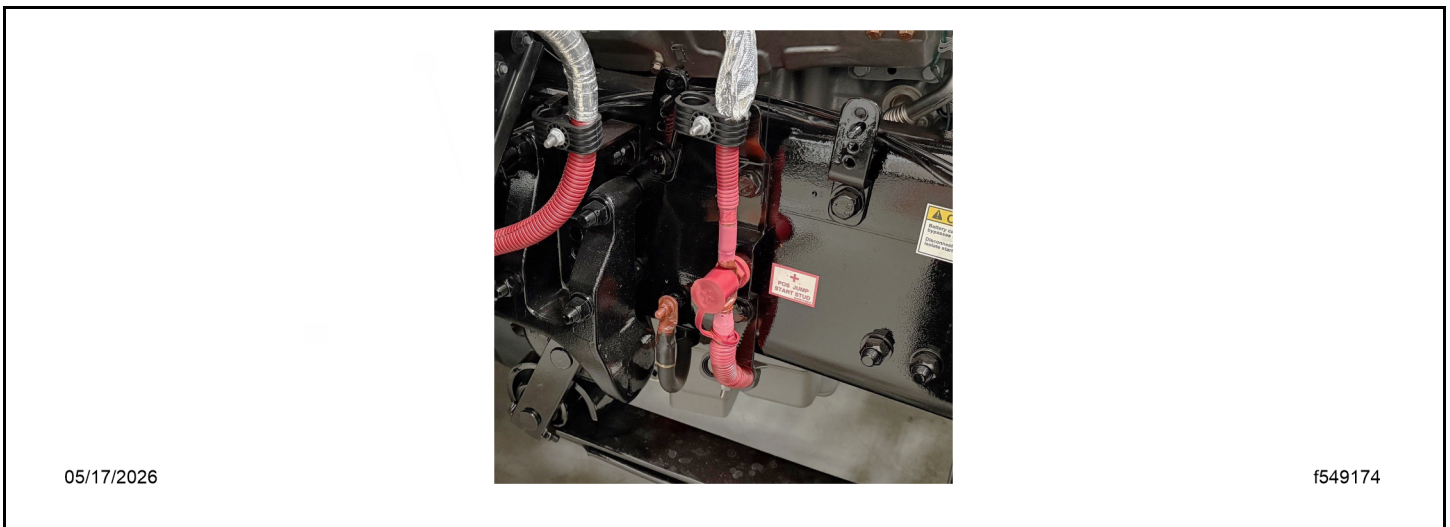

Fig 73, Isolated Battery Junction with Jump-Start Post

6. Remove the negative (-) cable connection(s) from the batteries.
7. If required for access, remove the splash shield from behind the front tire. For detailed instructions, see Group 88 of the *47X, 48X and 49X Workshop Manual*.
8. Remove the jump-start post or nut that secures the battery cable(s) to the isolated stud.
9. Remove the clamp(s) that secure the positive battery cables to the clipping point above the frame rail.
10. Remove the clamp(s) and ties that secure the positive battery cable routed between the isolated stud and the starter.
11. Remove the nut that secures the positive battery cables to the starter.
12. Remove the cable that connects the isolated stud to the starter.
13. Remove the bolts that secure the lower cable routing bracket to the frame.
14. Fit the jump-start cable bracket (12-25410-000), washer, and cable routing bracket on the frame bolt. Install the assembly in the frame hole.

F1029 A-O

Creation Date: May 2026

NHTSA #26V-079

Transport Canada #2026-054

15. Install the frame fastener nut. Tighten to allow the brackets to remain loose.
16. Position the jump-start support bracket bolt (N910105 008016) in the bracket.
NOTE: The bolt that secures the jump-start cable to the support bracket may be too long to be installed while the frame bolt is tight. Position the bolt in the bracket hole before tightening it.
17. Align the routing and jump-start support brackets vertically on the frame. Tighten the frame bolt to 148 lbf-ft (200 N·m).
18. Remove the isolated stud bracket from the frame.
19. Remove the stud from the bracket.
20. Install the isolated stud bracket.
 - a. Find the frame bolt closest to the square stud mounting hole. Position the bolt with the head on the inboard side of the frame.
 - b. Fit the routing bracket and washer. Hand tighten the nut.
 - c. Install the second frame bolt with the head on the outboard side of the frame.
 - d. Tighten both the bolts 148 lbf-ft (200 N·m).
21. If required, apply touch-up paint to the frame bolts.
22. Remove the ring terminals from the positive cables that are routed to the cab.
 - a. Note how the cables are secured and remove wire ties, tape, and convolute, as needed to uncover at least 6 inches of the cable.
 - b. Remove the original heat shrink. To do so, heat it, score it, and continue to heat it until the score splits and the adhesive softens. See Fig. [Fig. 74](#).

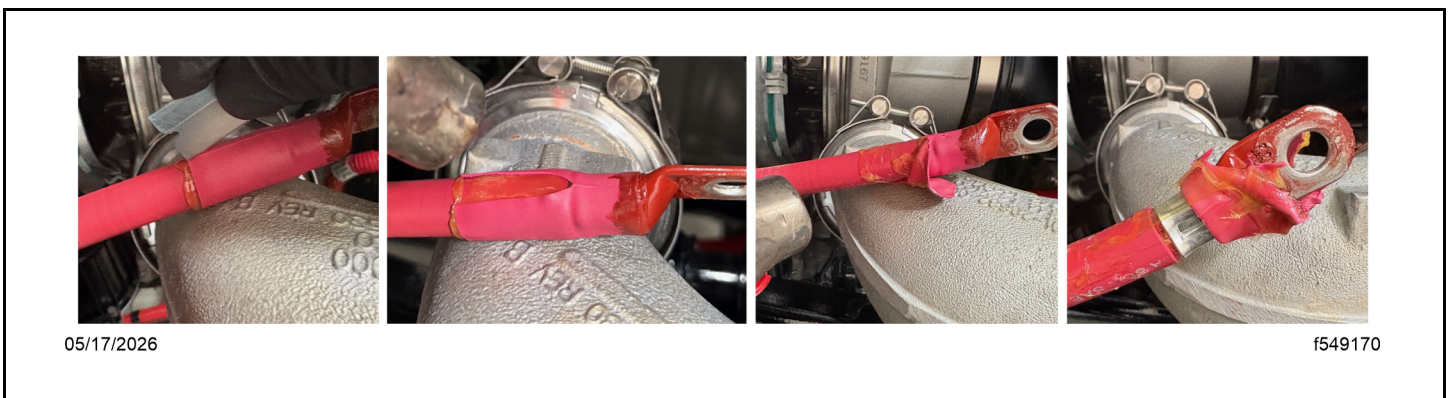

Fig 74, Heat Shrink Removal

- c. Cut the cable just above the ring terminal.
- d. Remove the cable insulation equal to half the butt connector length without damaging the wire strands. See Fig. [Fig. 75](#).

F1029 A-O

Creation Date: May 2026

NHTSA #26V-079

Transport Canada #2026-054



Fig 75, Removing the Insulation

- e. Straighten any bent strands of the conductor.
- f. Repeat steps 22a through 22e to remove the ring terminal from the second cable.

NOTE: To ensure proper crimp force is applied to the terminal, the cable cuts must be square and the number of damaged or lost strands must be minimized.

23. Inspect the conductors for evidence of corrosion. Is corrosion present on either of the newly exposed conductors?

NOTE: The cable must be replaced if cutting back the corrosion causes the cable to become too short for the butt terminal to be supported by the routing clamp above the frame rail.

- a. **YES** → Cut off about 1 inch (25 mm) of cable. Repeat steps 22d to 22e to remove the cable insulation. Evaluate the condition of the conductor.
- b. **NO** → Go to step 24.

F1029 A-O

Creation Date: May 2026

NHTSA #26V-079

Transport Canada #2026-054

24. Crimp the butt connector terminals (PHM 8 2960 and PHM 8 2980) on the cables routed to the cab. See Fig. [Fig. 76](#).

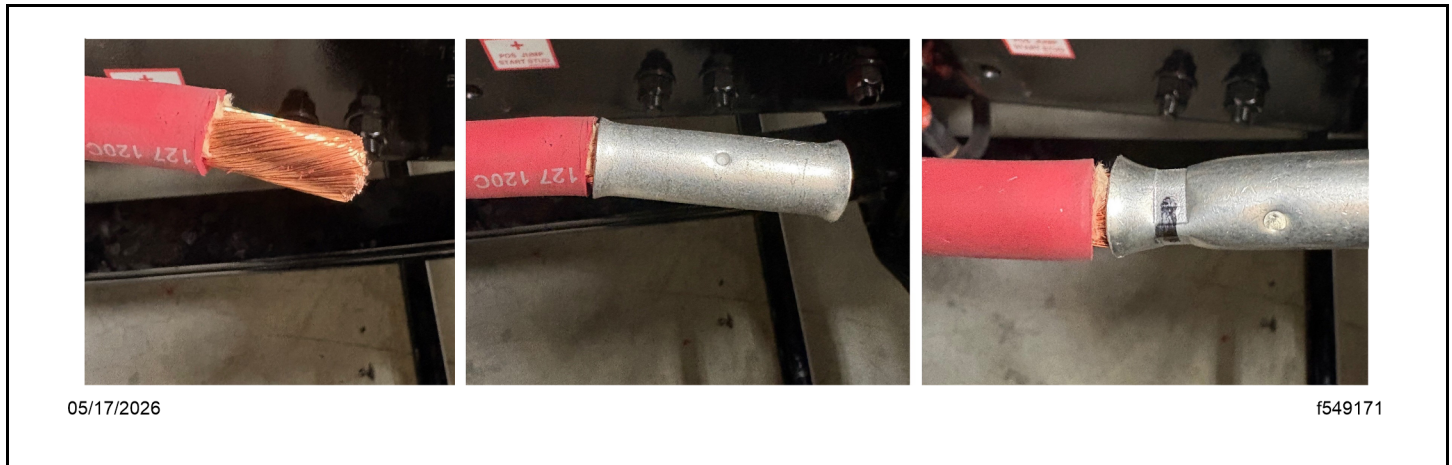

Fig 76, Installing and Crimping the Terminal

- a. Fully seat the conductor in the terminal.
- b. Adjust the crimping tool to the correct cable size.
- c. Position the crimping tool approximately 5/16 inch (8 mm) from the open end of the barrel. Crimp the terminal.
- d. Repeat steps 24a through 24c to crimp the second cable.

NOTE: To prevent the cable strands from entering the heat shrink over time, all the cable strands must be inserted into the terminal. If the cable strands are outside the barrel, wind them around the conductor in the gap between the cable insulation and the terminal. Apply electrical tape over the gap to prevent them from contacting the heat shrink layer.

25. Determine the length of the new jump-start cable (A66-12311-046).
- a. Compare the old starter cable to the new jump-start cable.
 - b. Remove the tape securing the convolute cover to access the cable.
 - c. Hold the jump-start cable up to the mounting hole on the support bracket.
 - d. Feed the cable under the frame following the path of the other cable(s) to the starter. Mark the cable where it passes the base of the positive post on the starter.
26. Adjust the length of the new jump-start cable. Replace the starter-end terminal.
- a. Remove the tape securing the convolute cover on the cable, if present.
 - b. Cut the cable squarely at the length determined in step 21.
 - c. Position the 4/0 diameter heat shrink sleeve (66-47062-000) on the cable.
 - d. Remove a minimum of 1.2 inch (32 mm) of the cable insulation without damaging the wire strands.
 - e. Straighten any bent strands of the conductor.
 - f. Fully seat the conductor in the terminal (23-13773-004).

F1029 A-O

Creation Date: May 2026

NHTSA #26V-079

Transport Canada #2026-054

- g. Position the new terminal according to the orientation drawing. See Fig. [Fig. 77](#).

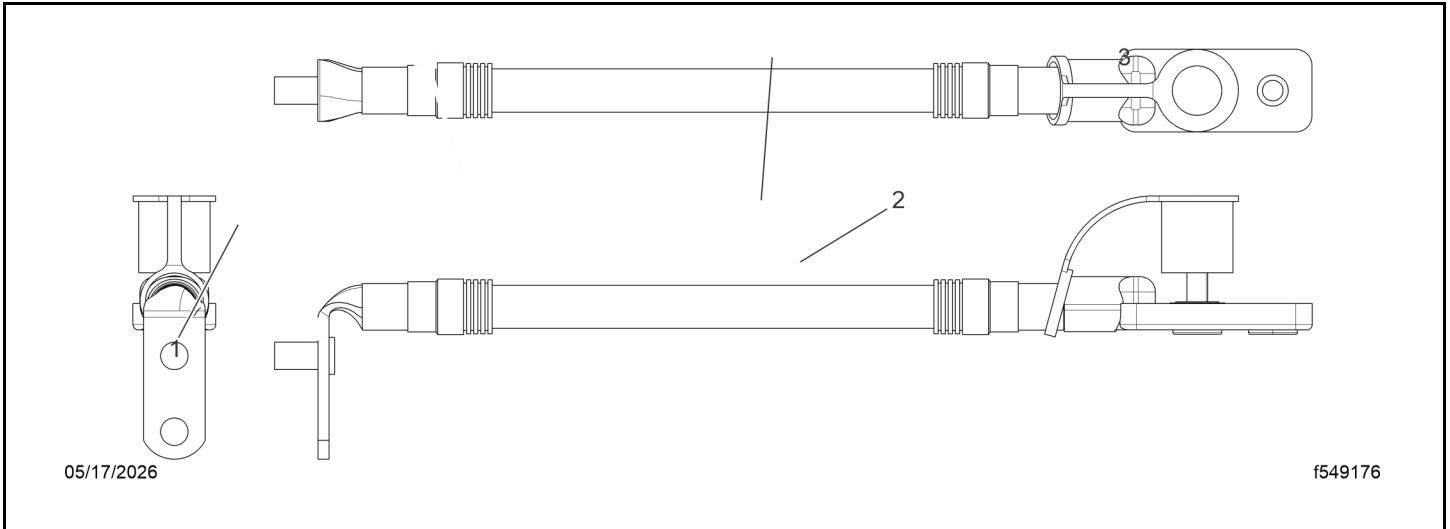

Fig 77, Jump-Start Cable Orientation

- h. Adjust the crimping tool to the correct cable size.
i. Position the crimping tool approximately 3/8 inch (9 mm) from the open end of the barrel and crimp the terminal.

NOTE: If the new jump-start cable terminal does not fit over the conductor easily, deburr the inside diameter of the barrel opening.

NOTE: If the strands of the conductor are too frayed to fit into the terminal barrel, use a small cable tie to make two wraps around the conductor near the end of the insulation. Tighten the tie and push it towards the end of the conductor to compact the strands. Stop with enough remaining conductor to start the terminal, push it on, and remove the tie.

27. Apply heat shrink to the cable.
- Slide the heat shrink into position on the terminal.
 - Activate the heat shrink sleeve by heating it evenly at one end until it adapts to the size of the terminal and the adhesive liquefies. Continue heating the sleeve on all sides, working from one end to the other.
 - Confirm a continuous ring of adhesive can be seen around the circumference of the sleeve at both ends. See Fig. [Fig. 78](#).

F1029 A-O

Creation Date: May 2026

NHTSA #26V-079

Transport Canada #2026-054

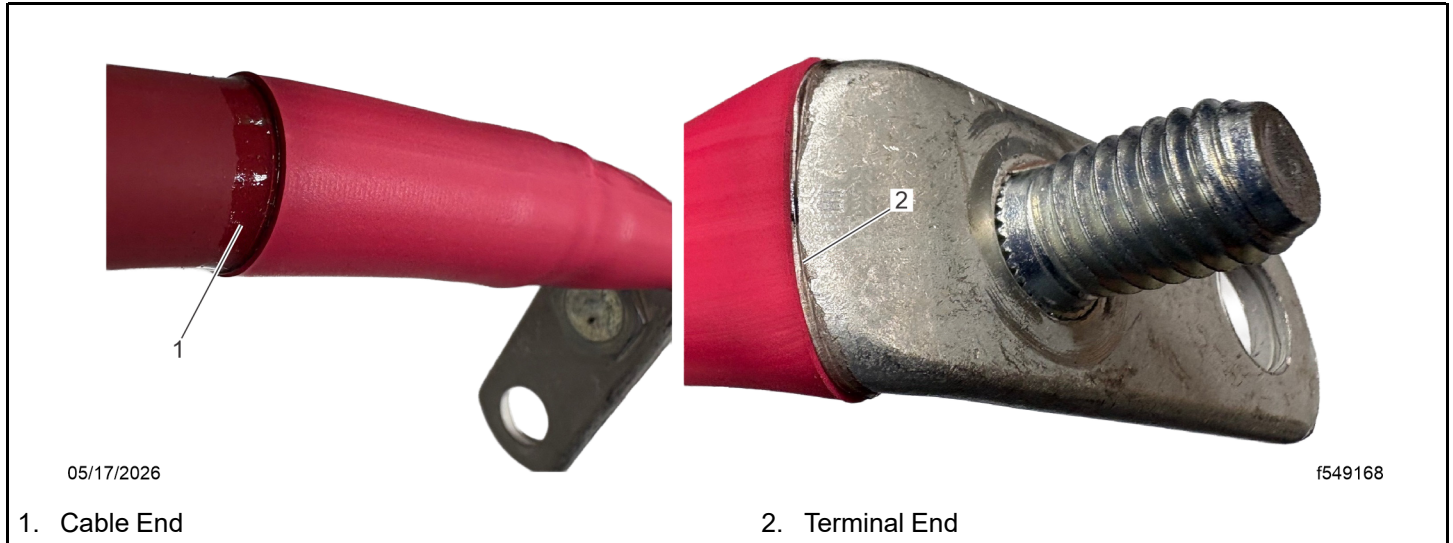

Fig 78, Continuous Adhesive Seal at Cable and Terminal Ends

- d. Install the convolute cover by applying red electrical tape to cover the transition from the heat shrink to the convolute cover. See Fig. [Fig. 79](#).

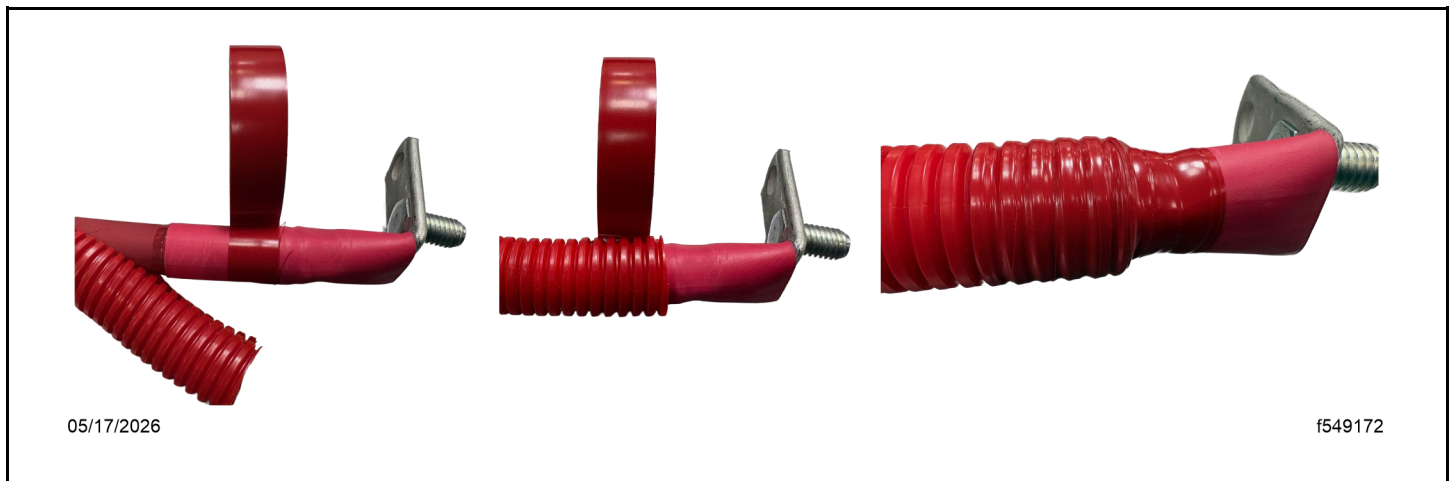

Fig 79, Installing the Convolute Cover

28. Install the convolute cover (48-25360-019) on the new auxiliary Battery Cable Access (BCA) cable (A06-35801-060).
 - a. Apply red electrical tape to cover the transition from the heat shrink to the convolute on the starter end of the cable.
 - b. From the starter end of the cable, add two tape rings at approximately 6 to 8 inch (150 to 200 mm) increments to secure the convolute to the cable. Leave the remaining cover loose until the butt connection has been made and sealed.

F1029 A-O

Creation Date: May 2026

NHTSA #26V-079

Transport Canada #2026-054

29. Assemble the new auxiliary BCA to the jump-start cable. See Fig. [Fig. 80](#).



Fig 80, Assembled Jump-Start and BCA Cables

- a. Position the auxiliary BCA cable end on the extra post of the jump-start cable to fit with the other cables on the starter. Ensure the two cables do not cross between the starter and the under-frame routing bracket.
 - b. Install the nut (23-09596-050) and washer (23-10900-050). Tighten the fasteners 19 lbf·ft (26 N·m).
30. Fit the new starter cable (A06-78035-065) to the positive terminal on the starter.
31. Install the jump-start auxiliary BCA cable assembly on the starter. Tighten 19 lbf·ft (26 N·m).
32. Apply dielectric red enamel paint to the exposed surfaces of the cable ends at the starter.

F1029 A-O

Creation Date: May 2026

NHTSA #26V-079

Transport Canada #2026-054

33. Route the starter and jump-start auxiliary BCA cables next to the other heavy positive cable(s) from the starter to the lower frame rail support bracket. See Fig. [Fig. 81](#).

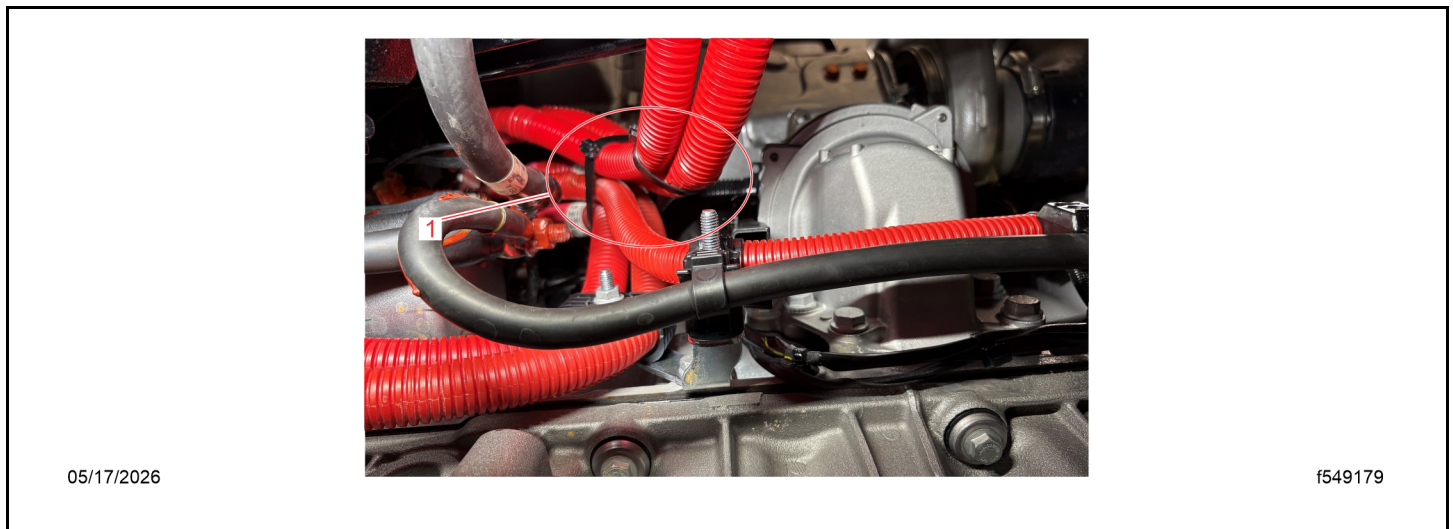

Fig 81, Securing the Cables

1. Secured Cables

34.

NOTE: If the cables routing under the frame include a ground cable utilizing the one of the two routing clamp holes, route the 4/0 cables in the original clamps and butterfly the BCA cable along the path using butterfly ties (TYCDCT110HIR).

Use the lower routing clamp to support the 4/0 positive starter cable as it routes under the frame. Route the jump-start cable beside it.

35. Use the lower routing clamp to support the 4/0 positive starter cable as it routes under the frame. Route the jump-start cable beside it.
36. Route the jump-start cable to the support bracket. Fit the cable and washer (23-10900-038). Apply medium strength thread locker and tighten the nut (23-12612-008) 14 lbf·ft (19 N·m).

F1029 A-O

Creation Date: May 2026

NHTSA #26V-079

Transport Canada #2026-054

37. Install the nylon nut (23-13379-001) on the tail of the bolt holding the jump-start cable to the support bracket (1). Tighten to 7 lbf-ft (9.5 N·m). See Fig. [Fig. 82](#).



Fig 82, Nylon Nut on Jump-Start Bracket Fastener

1. Nylon Nut

38. Determine the ideal length for the new auxiliary BCA cable and starter cable between the starter and butt connector. Cut the cables. See Fig. [Fig. 83](#).

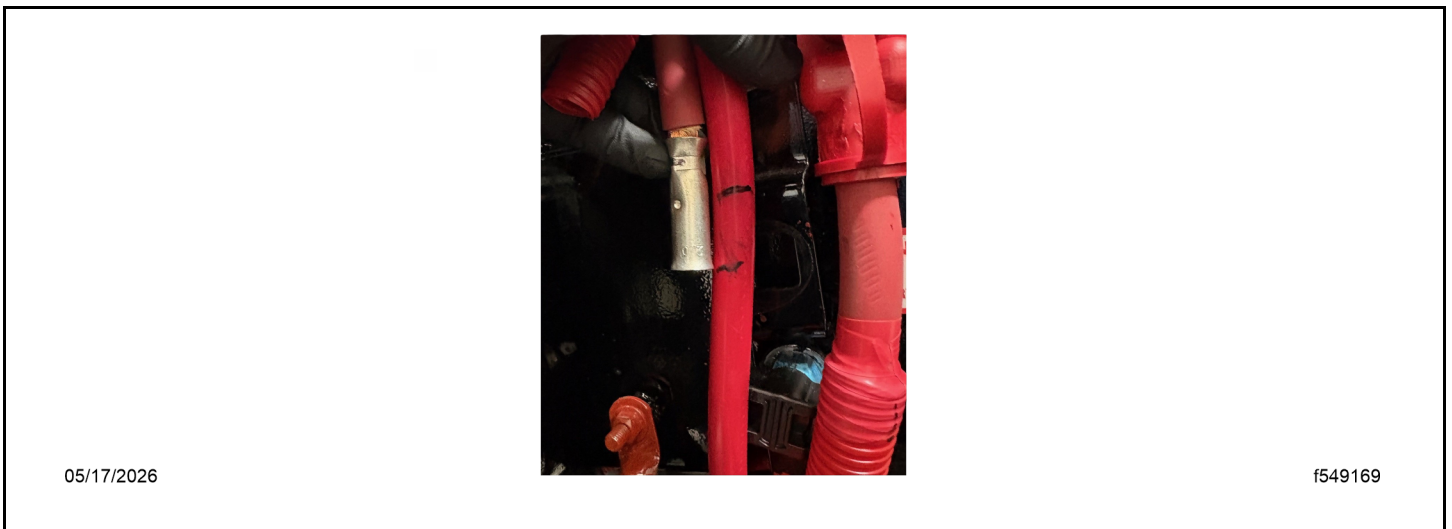

Fig 83, Determining the BCA Cable Length

F1029 A-O

Creation Date: May 2026

NHTSA #26V-079

Transport Canada #2026-054

39. Position three pieces of heat shrink tubing (66-47062-001) on the auxiliary BCA cable with one on the upper cable and two on the lower cable. Position three pieces of heat shrink tubing (66-47062-000) on the starter cable with one on each upper cable and two on each lower cable.

NOTE: Position the heat shrink tube to allow enough room to complete the butt crimp process without damaging it. If the heat shrink is damaged and splits during the heating process, the terminal must be replaced to ensure the connection is watertight.

40. Crimp the butt connectors.
- Remove the cable insulation equal to half the butt connector length without damaging the wire strands.
 - Straighten any bent conductor strands.
 - Fully seat the conductor in the terminal.
 - Adjust the crimping tool to the correct cable size.
 - Crimp the terminal.
 - Repeat steps 40a through 40e to crimp the second cable.
41. Insulate the butt connections with heat shrink sleeves. See Fig. [Fig. 84](#).

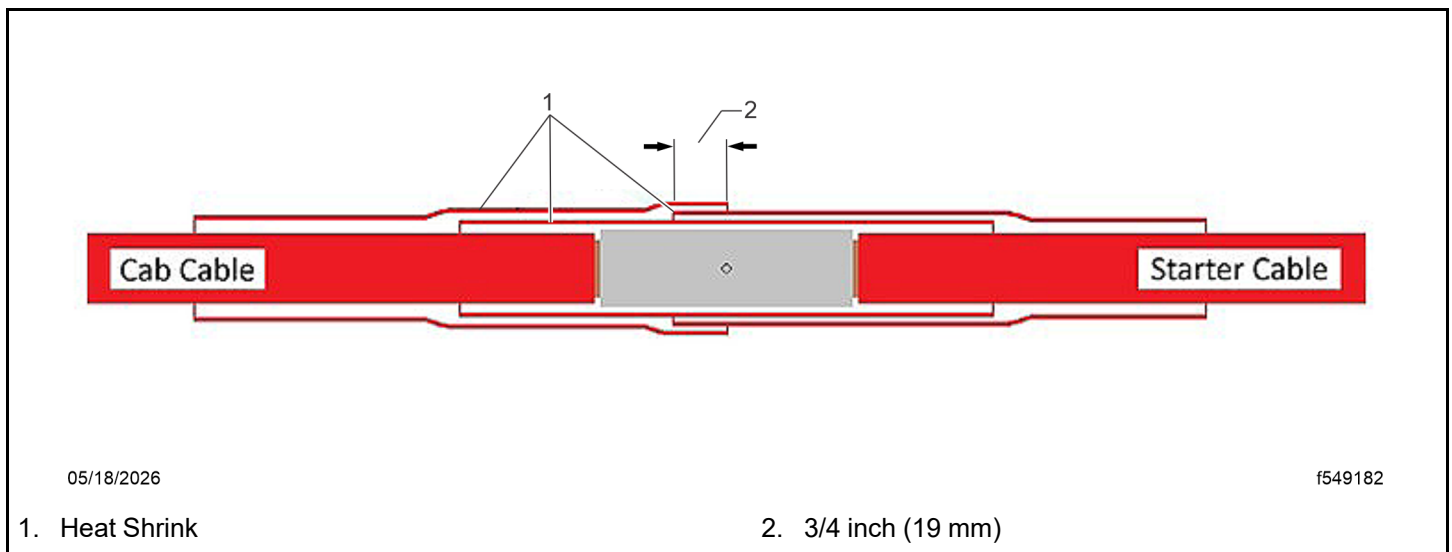

Fig 84, Heat Shrink Insulation

- Center the first piece of heat shrink sleeve on the terminal.
- Activate the sleeve by heating it evenly from one end until it adapts to the size of the cable and the adhesive liquefies.
- Continue heating the sleeve on all sides, working from one end to the other.
- Confirm a continuous ring of adhesive can be seen around the circumference of the sleeve at both ends.
- Position the second sleeve on the lower cable and overlap the center of the first sleeve by 3/4 inch (19 mm).

F1029 A-O

Creation Date: May 2026

NHTSA #26V-079

Transport Canada #2026-054

- f. Activate the second sleeve by heating it evenly from one end until it adapts to the size of the cable and the adhesive liquefies.
 - g. Continue heating the second sleeve on all sides, working from one end to the other.
 - h. Confirm a continuous ring of adhesive can be seen around the circumference of the second sleeve at both ends.
 - i. Position the third sleeve on the upper cable and overlap the top of the second sleeve by 3/4 inch (19 mm).
 - j. Activate the third sleeve and inspect for a continuous ring of sealant at both ends.
 - k. Repeat steps 41a through 41j to insulate the second cable.
42. Cover the heat shrink joint with convolute tubing. If extra convolute tubing is required, use 4/0 Red Slit Convolute (48-25360-022) for 4/0 cables, and CONDUIT-NYL, 19MM, FLEX (48-25360-019) for 2/0 cables.
 43. Apply red electrical tape to the cable and to the convolute end to create a seamless transition between the ends of the convolute on both cables.
 44. Install the 5/8 inch routing block (23-13805-062) on the frame bolt for the isolated stud bracket with the threads on the outside of the frame.
 45. Install the upper and lower cable clamps on the isolator frame bracket. To prevent cables (A) from rubbing, secure any cables routed on the outside cable clamps (B) using butterfly cable ties (C) (TYCDCT110HIR). See Fig. **Fig. 85**.

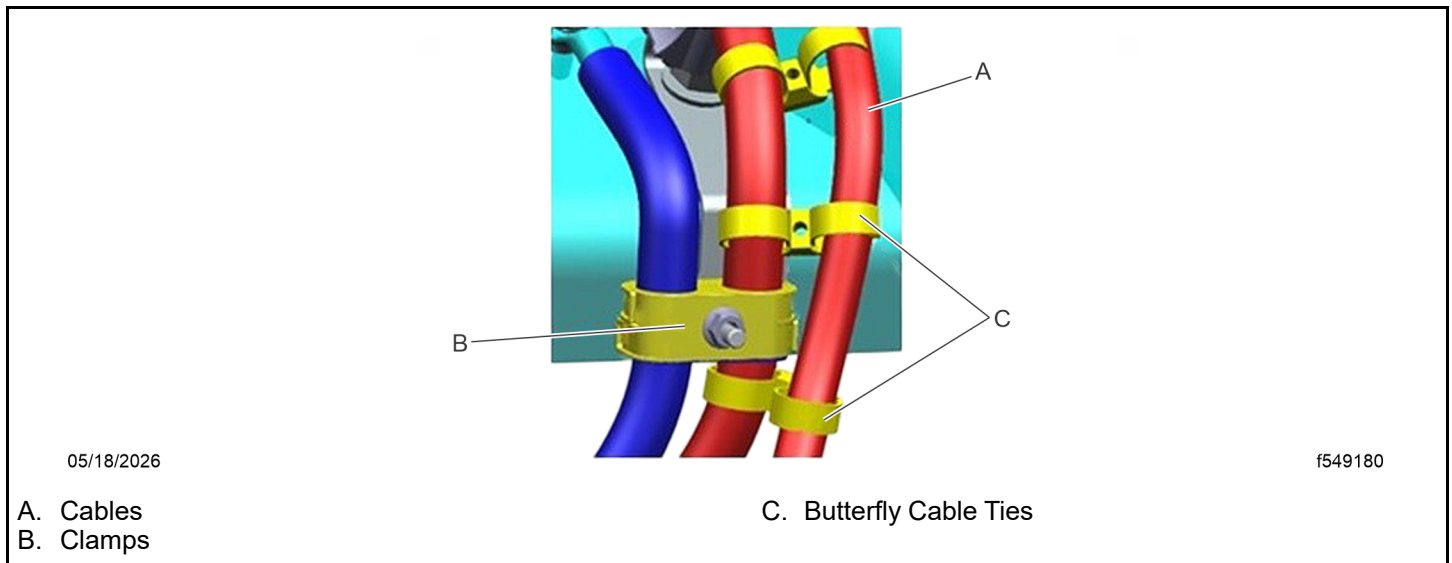

Fig 85, Butterfly Cable Ties Around the Cable Clamps

46. Secure the cables with a Heavy Duty (HD) cable tie (23-13476-000) along the path where positive power cables are routed together.
 47. Use butterfly cable ties (TYCDCT110HIR) to route positive cables next to any other cables or anywhere along the path where cables must be separated.
- IMPORTANT: Ensure no power cables are rubbing, or close to rubbing, the frame or engine components.

F1029 A-O

Creation Date: May 2026

NHTSA #26V-079

Transport Canada #2026-054

48. If removed, install the splash shield behind the front tire. For detailed instructions, see Group 88 of the *47X, 48X and 49X Workshop Manual*.
49. Install the negative cable connections at the batteries.
50. Clean a spot on the base label (Form WAR259) and attach a campaign completion sticker for F1029 (Form WAR260).

F1029 A-O

Creation Date: May 2026

NHTSA #26V-079

Transport Canada #2026-054

Group H Work Instructions

1. Check the base label (Form WAR259) for a completion sticker for F1029 (Form WAR260), indicating this work has been done. The base label is usually located on the passenger-side door, about 12 inches (30 cm) below the door latch. If a completion sticker is present, no work is needed. If a completion sticker is not present, proceed to the next step.
2. Park the vehicle on a level surface and set the parking brake. Chock the rear tires.
3. Turn the steer tires to the right to make the isolated stud accessible. Shut down the engine.
4. Open the hood.
5. Locate the isolated positive (+) battery stud mounted on the frame behind the front wheel. See Fig. [Fig. 86](#).

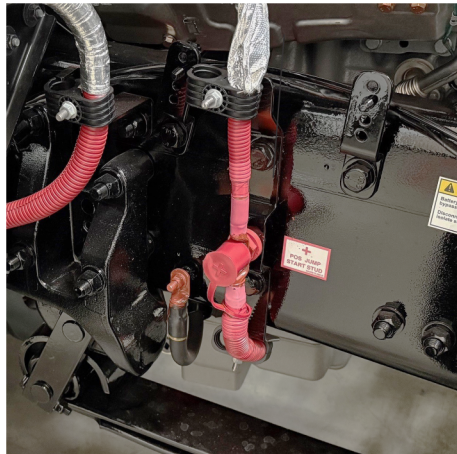

05/17/2026

f549174

Fig 86, Isolated Battery Junction with Jump-Start Post

6. Remove the negative (-) cable connection(s) from the batteries.
7. If required for access, remove the splash shield from behind the front tire. For detailed instructions, see Group 88 of the *47X, 48X and 49X Workshop Manual*.
8. Remove the jump-start post or nut that secures the battery cable(s) to the isolated stud.
9. Remove the clamp(s) that secure the positive battery cables to the clipping point above the frame rail.
10. Remove the clamp(s) and ties that secure the positive battery cable routed between the isolated stud and the starter.
11. Remove the nut that secures the positive battery cables to the starter.
12. Remove the cable that connects the isolated stud to the starter.
13. Remove the bolts that secure the isolated stud bracket to the frame.
14. Remove the isolated stud from the frame bracket.
15. Fit the lower isolator bracket frame bolt in position with the head on the inboard side of the frame.

F1029 A-O

Creation Date: May 2026

NHTSA #26V-079

Transport Canada #2026-054

16. Install the upper isolator bracket frame bolt with head on the outside of the frame. Tighten both bolts to 148 lbf·ft (200 N·m).
17. Remove the top bolt from the frame mounted routing and clipping bracket in front of the isolated stud bracket.
18. Install the new jump-start cable bracket (12-25410-000) on the clipping bracket frame bolt, followed by the washer. Position the assembly in the frame hole. Hand-tighten the fasteners to keep the bracket in position.
19. Remove the ring terminals from the positive cables that are routed to the cab.
 - a. Note how the cables are secured and remove wire ties, tape, and convolute, as needed to uncover at least 6 inches of the cable.
 - b. Remove the original heat shrink. To do so, heat it, score it, and continue to heat it until the score splits and the adhesive softens. See Fig. [Fig. 87](#).

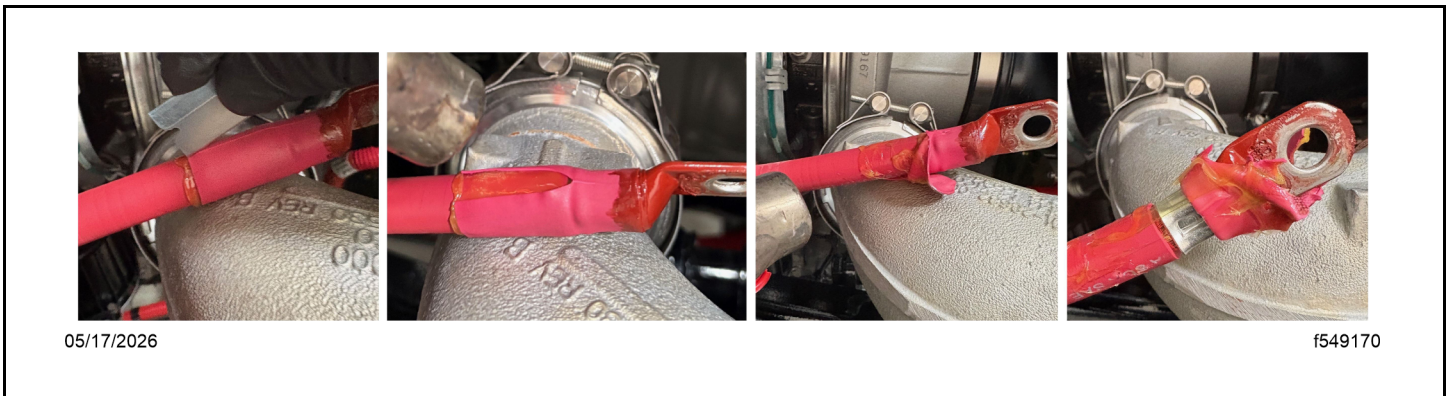

Fig 87, Heat Shrink Removal

- c. Cut the cable just above the ring terminal.
- d. Remove the cable insulation equal to half the butt connector length without damaging the wire strands. See Fig. [Fig. 88](#).

F1029 A-O

Creation Date: May 2026

NHTSA #26V-079

Transport Canada #2026-054



Fig 88, Removing the Insulation

- e. Straighten any bent strands of the conductor.
- f. Repeat steps 19a through 19e to remove the ring terminal from the second cable.

NOTE: To ensure proper crimp force is applied to the terminal, the cable cuts must be square and the number of damaged or lost strands must be minimized.

20. Inspect the conductors for evidence of corrosion. Is corrosion present on either of the newly exposed conductors?
- NOTE:** The cable must be replaced if cutting back the corrosion causes the cable to become too short for the butt terminal to be supported by the routing clamp above the frame rail.
- a. **YES** → Cut off about 1 inch (25 mm) of cable. Repeat steps 19d to 19e to remove the cable insulation. Evaluate the condition of the conductor.
 - b. **NO** → Go to step 21.

F1029 A-O

Creation Date: May 2026

NHTSA #26V-079

Transport Canada #2026-054

21. Crimp the butt connector terminals (PHM 8 2960 and PHM 8 2980) on the cables routed to the cab. See Fig. [Fig. 89](#).

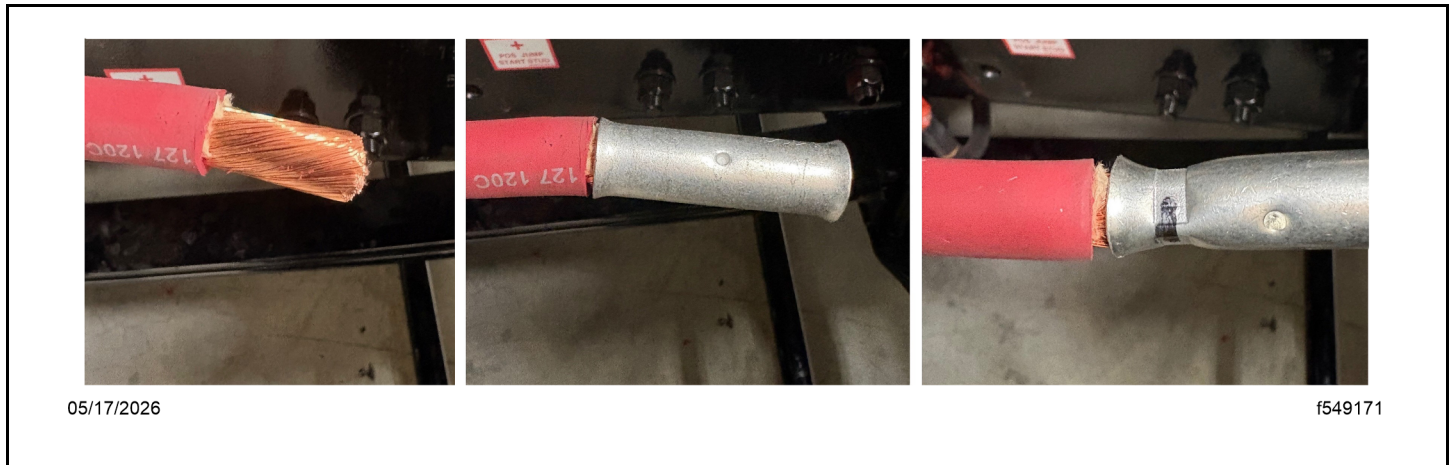

Fig 89, Installing and Crimping the Terminal

- a. Fully seat the conductor in the terminal.
- b. Adjust the crimping tool to the correct cable size.
- c. Position the crimping tool approximately 5/16 inch (8 mm) from the open end of the barrel. Crimp the terminal.
- d. Repeat steps 19a through 19c to crimp the second cable.

NOTE: To prevent the cable strands from entering the heat shrink over time, all the cable strands must be inserted into the terminal. If the cable strands are outside the barrel, wind them around the conductor in the gap between the cable insulation and the terminal. Apply electrical tape over the gap to prevent them from contacting the heat shrink layer.

22. Determine the length of the new jump-start cable (A66-12311-046).
- a. Compare the old starter cable to the new jump-start cable.
 - b. Remove the tape securing the convolute cover to access the cable.
 - c. Hold the jump-start cable up to the mounting hole on the support bracket.
 - d. Feed the cable under the frame following the path of the other cable(s) to the starter. Mark the cable where it passes the base of the positive post on the starter.
23. Adjust the length of the new jump-start cable. Replace the starter-end terminal.
- a. Remove the tape securing the convolute cover on the cable, if present.
 - b. Cut the cable squarely at the length determined in step 21.
 - c. Position the 4/0 diameter heat shrink sleeve (66-47062-000) on the cable.
 - d. Remove a minimum of 1.2 inch (32 mm) of the cable insulation without damaging the wire strands.
 - e. Straighten any bent strands of the conductor.
 - f. Fully seat the conductor in the terminal (23-13773-004).

F1029 A-O

Creation Date: May 2026

NHTSA #26V-079

Transport Canada #2026-054

- g. Position the new terminal according to the orientation drawing. See Fig. [Fig. 90](#).

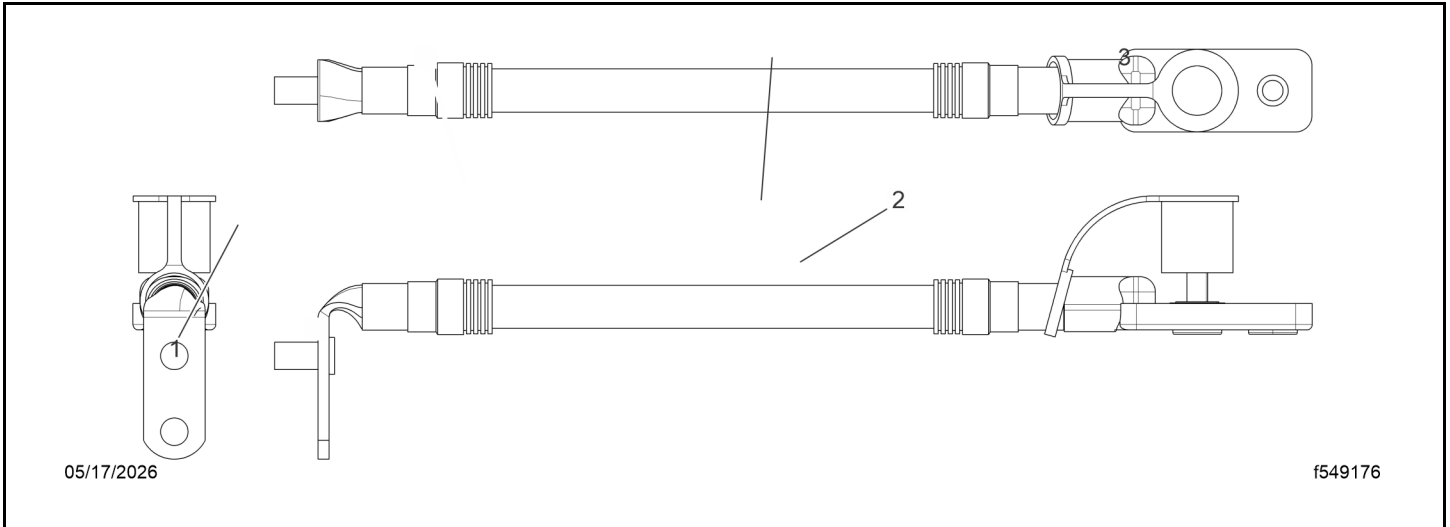

Fig 90, Jump-Start Cable Orientation

- h. Adjust the crimping tool to the correct cable size.
i. Position the crimping tool approximately 3/8 inch (9 mm) from the open end of the barrel and crimp the terminal.

NOTE: If the new jump-start cable terminal does not fit over the conductor easily, deburr the inside diameter of the barrel opening.

NOTE: If the strands of the conductor are too frayed to fit into the terminal barrel, use a small cable tie to make two wraps around the conductor near the end of the insulation. Tighten the tie and push it towards the end of the conductor to compact the strands. Stop with enough remaining conductor to start the terminal, push it on, and remove the tie.

24. Apply heat shrink to the cable.
- Slide the heat shrink into position on the terminal.
 - Activate the heat shrink sleeve by heating it evenly at one end until it adapts to the size of the terminal and the adhesive liquefies. Continue heating the sleeve on all sides, working from one end to the other.
 - Confirm a continuous ring of adhesive can be seen around the circumference of the sleeve at both ends. See Fig. [Fig. 91](#).

F1029 A-O

Creation Date: May 2026

NHTSA #26V-079

Transport Canada #2026-054

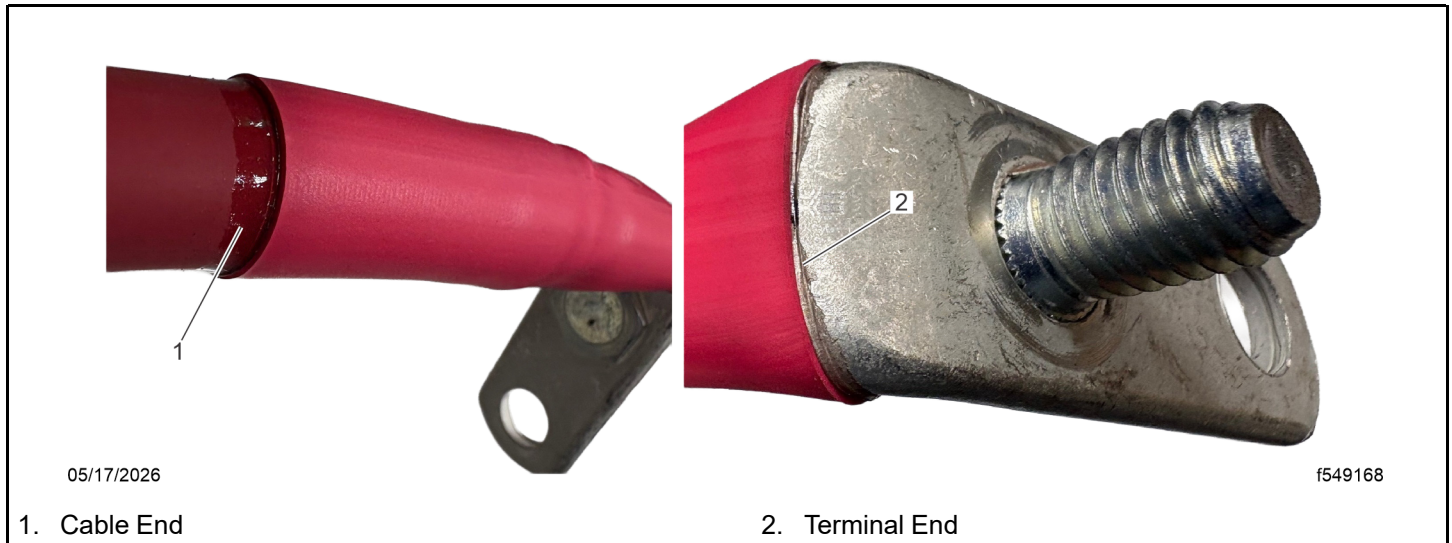

Fig 91, Continuous Adhesive Seal at Cable and Terminal Ends

- d. Install the convolute cover by applying red electrical tape to cover the transition from the heat shrink to the convolute cover. See Fig. [Fig. 92](#).

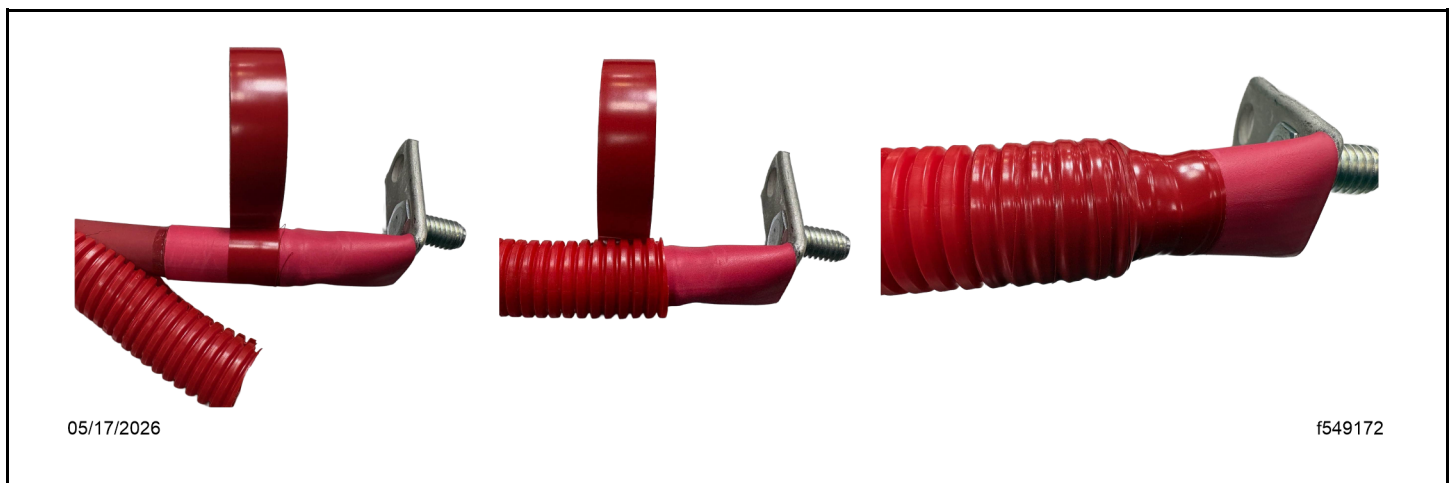

Fig 92, Installing the Convolute Cover

25. Install the convolute cover (48-25360-019) on the new auxiliary Battery Cable Access (BCA) cable (A06-35801-060).
 - a. Apply red electrical tape to cover the transition from the heat shrink to the convolute on the starter end of the cable.
 - b. From the starter end of the cable, add two tape rings at approximately 6 to 8 inch (150 to 200 mm) increments to secure the convolute to the cable. Leave the remaining cover loose until the butt connection has been made and sealed.

F1029 A-O

Creation Date: May 2026

NHTSA #26V-079

Transport Canada #2026-054

26. Assemble the new auxiliary BCA to the jump-start cable. See Fig. [Fig. 93](#).



Fig 93, Assembled Jump-Start and BCA Cables

- a. Position the auxiliary BCA cable end on the extra post of the jump-start cable to fit with the other cables on the starter. Ensure the two cables do not cross between the starter and the under-frame routing bracket.
 - b. Install the nut (23-09596-050) and washer (23-10900-050). Tighten the fasteners 19 lbf·ft (26 N·m).
27. Fit the new starter cable (A06-78035-065) to the positive terminal on the starter.
28. Install the jump-start auxiliary BCA cable assembly on the starter. Tighten 19 lbf·ft (26 N·m).
29. Apply dielectric red enamel paint to the exposed surfaces of the cable ends at the starter.

F1029 A-O

Creation Date: May 2026

NHTSA #26V-079

Transport Canada #2026-054

30. Install the 5/8 inch tie block (23-13805-062) on the bottom isolator bracket frame bolt so the cable routing can be set passing by it. See Fig. [Fig. 94](#).

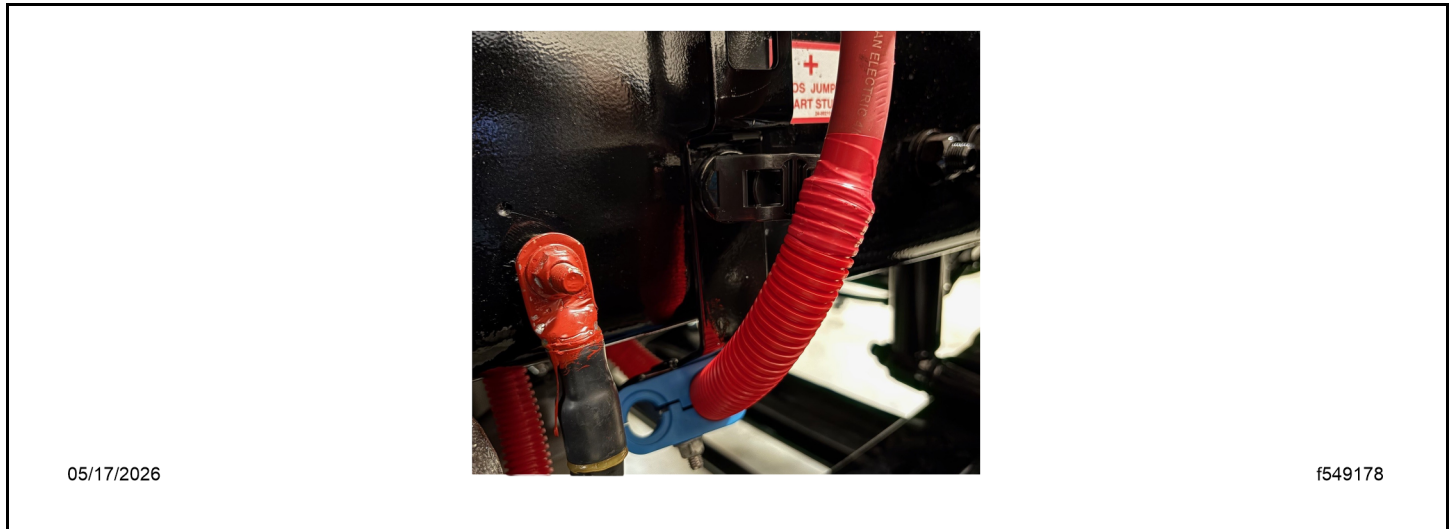

Fig 94, Routing Over the Tie Block

31. Route the starter and jump-start auxiliary BCA cables next to the other heavy positive cable(s) from the starter to the lower frame rail support bracket. See Fig. [Fig. 95](#).

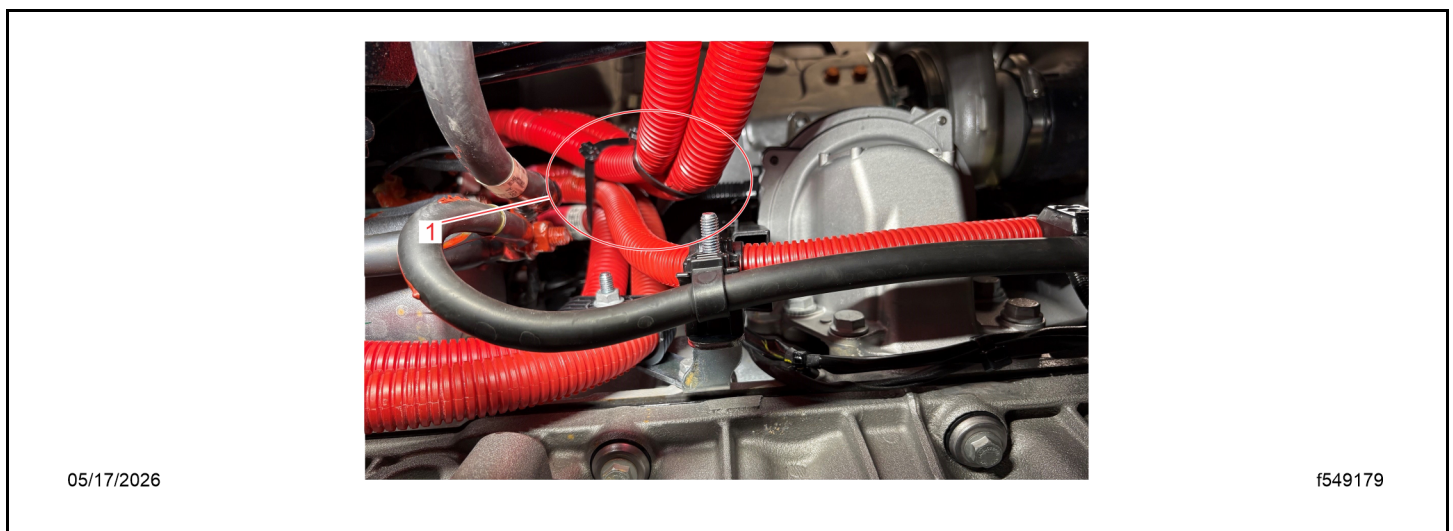

Fig 95, Securing the Cables

F1029 A-O

Creation Date: May 2026

NHTSA #26V-079

Transport Canada #2026-054

1. Secured Cables

32.

NOTE: If the cables routing under the frame include a ground cable utilizing the one of the two routing clamp holes, route the 4/0 cables in the original clamps and butterfly the BCA cable along the path using butterfly ties (TYCDCT110HIR).

Use the lower routing clamp to support the 4/0 positive starter cable as it routes under the frame. Route the jump-start cable beside it.

33. Use the lower routing clamp to support the 4/0 positive starter cable as it routes under the frame. Route the jump-start cable beside it.

34. Route the jump-start cable to the support bracket and the bolt (N910105 008016), cable, washer (23-10900-038), and nut (23-12612-008). Hand-tighten the fasteners. See Fig. [Fig. 96](#).



Fig 96, Jump-Start Cable Support Bracket

35. Remove the 5/8 inch tie block. Tighten the frame bolts that secure the isolator and clipping brackets to the frame rail to 148 lbf·ft (200 N·m).

36. If required, apply touch-up paint to the frame bolts.

37. Install the 5/8 inch tie block (23-13805-062) on the bottom isolator bracket frame bolt.

F1029 A-O

Creation Date: May 2026

NHTSA #26V-079

Transport Canada #2026-054

38. Determine the ideal length for the auxiliary BCA cable and starter cable between the starter and butt connector. Cut the cables. See Fig. [Fig. 97](#).

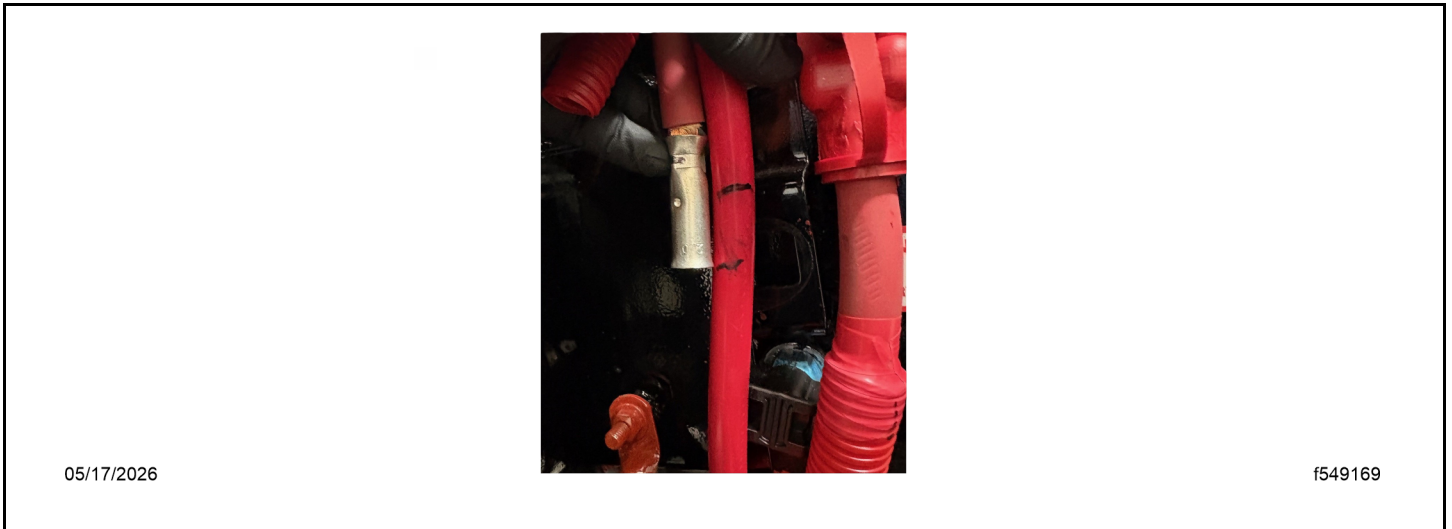

Fig 97, Determining the BCA Cable Length

39. Position three pieces of heat shrink tubing (66-47062-001) on the auxiliary BCA cable with one on the upper cable and two on the lower cable. Position three pieces of heat shrink tubing (66-47062-000) on the starter cable with one on each upper cable and two on each lower cable.

NOTE: Position the heat shrink tube to allow enough room to complete the butt crimp process without damaging it. If the heat shrink is damaged and splits during the heating process, the terminal must be replaced to ensure the connection is watertight.

40. Crimp the butt connectors.
- Remove the cable insulation equal to half the butt connector length without damaging the wire strands.
 - Straighten any bent conductor strands.
 - Fully seat the conductor in the terminal.
 - Adjust the crimping tool to the correct cable size.
 - Crimp the terminal.
 - Repeat steps 40a through 40c to crimp the second cable.

F1029 A-O

Creation Date: May 2026

NHTSA #26V-079

Transport Canada #2026-054

41. Insulate the butt connections with heat shrink sleeves. See Fig. Fig. 98.

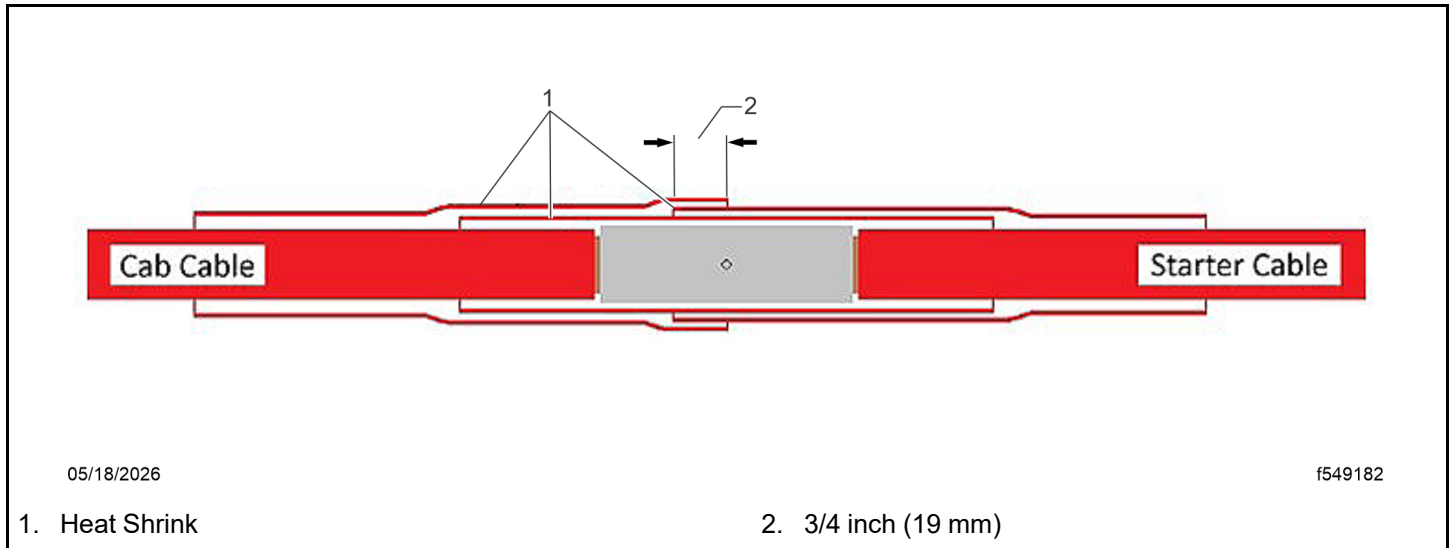

Fig 98, Heat Shrink Insulation

- a. Center the first piece of heat shrink sleeve on the terminal.
 - b. Activate the sleeve by heating it evenly from one end until it adapts to the size of the cable and the adhesive liquefies.
 - c. Continue heating the sleeve on all sides, working from one end to the other.
 - d. Confirm a continuous ring of adhesive can be seen around the circumference of the sleeve at both ends.
 - e. Position the second sleeve on the lower cable and overlap the center of the first sleeve by 3/4 inch (19 mm).
 - f. Activate the second sleeve by heating it evenly from one end until it adapts to the size of the cable and the adhesive liquefies.
 - g. Continue heating the second sleeve on all sides, working from one end to the other.
 - h. Confirm a continuous ring of adhesive can be seen around the circumference of the second sleeve at both ends.
 - i. Position the third sleeve on the upper cable and overlap the top of the second sleeve by 3/4 inch (19 mm).
 - j. Activate the third sleeve and inspect for a continuous ring of sealant at both ends.
 - k. Repeat steps 41a through 41j to insulate the second cable.
42. Cover the heat shrink joints with convolute tubing. If extra convolute tubing is required, use 4/0 Red Slit Convolute (48-25360-022) for 4/0 cables, and CONDUIT-NYL,19MM,FLEX (48-25360-019) for 2/0 cables.
43. Apply red electrical tape to the cable and to the convolute end to create a seamless transition between the ends of the convolute.

F1029 A-O

Creation Date: May 2026

NHTSA #26V-079

Transport Canada #2026-054

44. Install the upper and lower cable clamps on the isolator frame bracket. To prevent cables (A) from rubbing, secure any cables routed on the outside cable clamps (B) using butterfly cable ties (C) (TYCDCT110HIR). See Fig. Fig. 99.

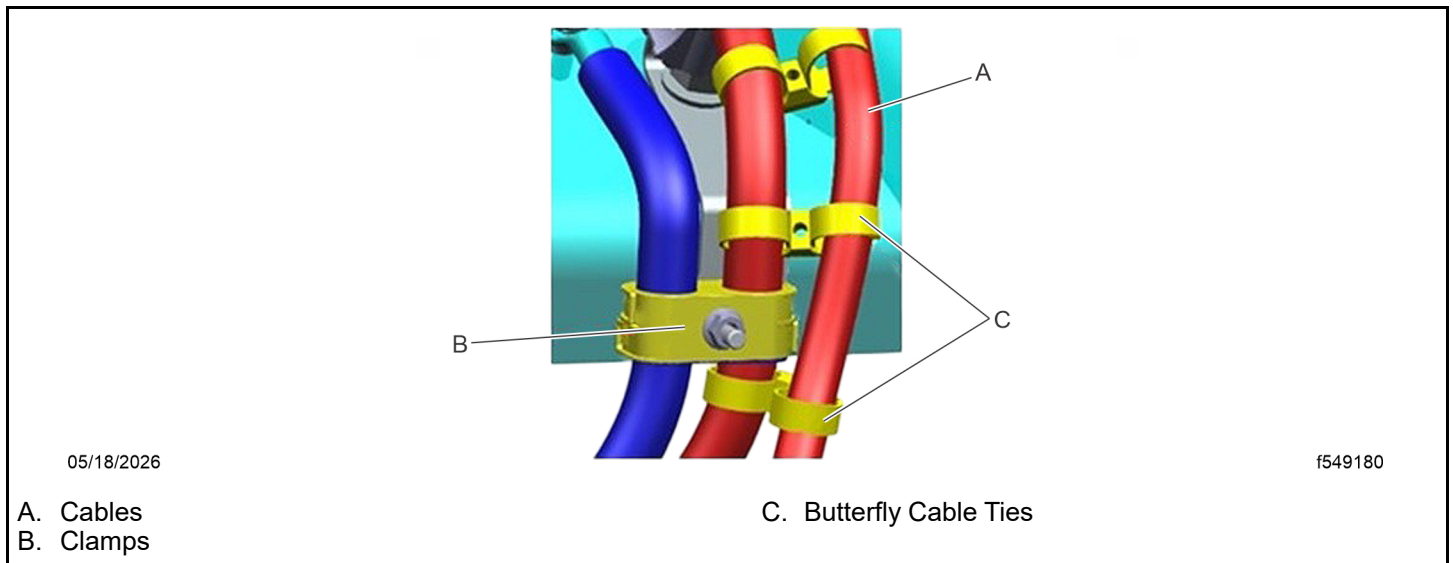

Fig 99, Butterfly Cable Ties Around the Cable Clamps

45. Secure the cables to the 5/8 inch tie block with a Heavy Duty (HD) cable tie (23-13476-000) and other points where positive power cables are routed together.
46. Use butterfly cable ties (TYCDCT110HIR) to route positive cables next to any other cables or anywhere along the path where cables must be separated.
- IMPORTANT: Ensure no power cables are rubbing, or close to rubbing, the frame or engine components.
47. Remove the nut holding the jump-start cable to the support bracket. Apply medium strength thread locker. Install the assembly. Tighten 14 lbf·ft (19 N·m).

F1029 A-O

Creation Date: May 2026

NHTSA #26V-079

Transport Canada #2026-054

48. Install the nylon nut (23-13379-001) on the tail of the bolt holding the jump-start cable to the support bracket (1). Tighten 7 lbf·ft (9.5 N·m). See Fig. **Fig. 100**.



Fig 100, Nylon Nut on Jump-Start Bracket Fastener

1. Nylon Nut
49. If removed, install the splash shield behind the front tire. For detailed instructions, see Group 88 of the *47X, 48X and 49X Workshop Manual*.
50. Install the negative cable connections at the batteries.
51. Clean a spot on the base label (Form WAR259) and attach a campaign completion sticker for F1029 (Form WAR260).

F1029 A-O

Creation Date: May 2026

NHTSA #26V-079

Transport Canada #2026-054

Group I Work Instructions

1. Check the base label (Form WAR259) for a completion sticker for F1029 (Form WAR260), indicating this work has been done. The base label is usually located on the passenger-side door, about 12 inches (30 cm) below the door latch. If a completion sticker is present, no work is needed. If a completion sticker is not present, proceed to the next step.
2. Park the vehicle on a level surface and set the parking brake. Chock the rear tires.
3. Turn the steer wheels to the left side to make the isolated stud accessible. Shut down the engine.
4. Open the hood.
5. Locate the isolated positive (+) battery stud mounted on the frame behind the front wheel. See Fig. [Fig. 101](#).

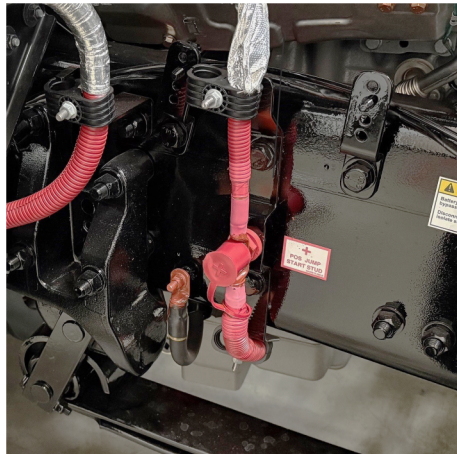

05/17/2026

f549174

Fig 101, Isolated Battery Junction with Jump-Start Post

6. Remove the negative (-) cable connection(s) from the batteries.
7. If required for access, remove the splash shield from behind the front tire. For detailed instructions, see Group 88 of the *47X, 48X and 49X Workshop Manual*.
8. Remove the jump-start post or nut that secures the battery cable(s) to the isolated stud.
9. Remove the clamp(s) that secure the positive battery cables to the clipping point above the frame rail.
10. Remove the clamp(s) and ties that secure the positive battery cable routed between the isolated stud and the starter.
11. Remove the nut that secures the positive battery cables to the starter.
12. Remove the cable that connects the isolated stud to the starter.
13. Remove the bolts that secure the isolated stud bracket to the frame.
14. Remove the isolated stud from the frame bracket.
15. Fit the lower isolator bracket frame bolt in position with the head on the inboard side of the frame.

F1029 A-O

Creation Date: May 2026

NHTSA #26V-079

Transport Canada #2026-054

16. Fit the isolator bracket, washer, and nut. Hand-tighten the fasteners to keep the bracket in position.
17. Fit the jump-start cable bracket (12-25410-000) on the upper frame bolt followed by the washer. Position the bracket in the frame hole and tighten to keep it in position.
18. Remove the ring terminal from the positive cable that is routed to the cab.
 - a. Note how the cable is secured and remove any cable ties, tape, or convolute as needed to uncover at least 6 inches of the cable.
 - b. Remove the original heat shrink. To do so, heat it, score it, and continue to heat it until the score splits and the adhesive softens. See Fig. [Fig. 102](#).

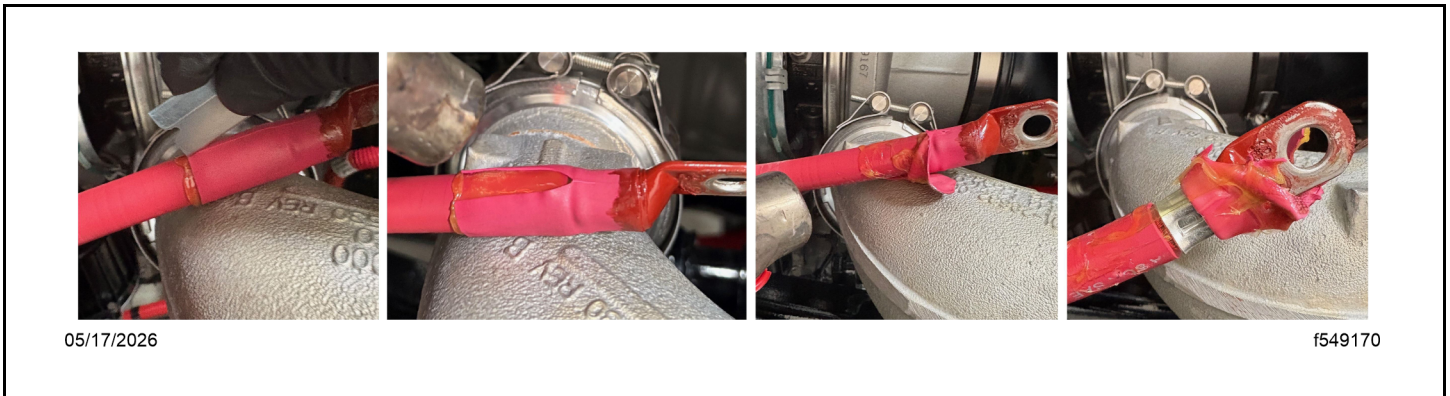

Fig 102, Heat Shrink Removal

- c. Cut the cable just above the ring terminal.
- d. Remove the cable insulation equal to half the butt connector length without damaging the wire strands. See Fig. [Fig. 103](#).

F1029 A-O

Creation Date: May 2026

NHTSA #26V-079

Transport Canada #2026-054



Fig 103, Removing the Insulation

e. Straighten any bent strands of the conductor.

NOTE: To ensure proper crimp force is applied to the terminal, the cable cuts must be square and the number of damaged or lost strands must be minimized.

19. Inspect the conductor for evidence of corrosion. Is corrosion present on the newly exposed conductor?

NOTE: The cable must be replaced if cutting back the corrosion causes the cable to become too short for the butt terminal to be supported by the routing clamp above the frame rail.

a. **YES** → Cut off about 1 inch (25 mm) of cable. Repeat steps 18d through 18e to remove the cable insulation. Evaluate the condition of the conductor.

b. **NO** → Go to step 20.

F1029 A-O

Creation Date: May 2026

NHTSA #26V-079

Transport Canada #2026-054

20. Crimp the butt connector terminal (PHM 8 2960) on the cable routed to the cab. See Fig. [Fig. 104](#).

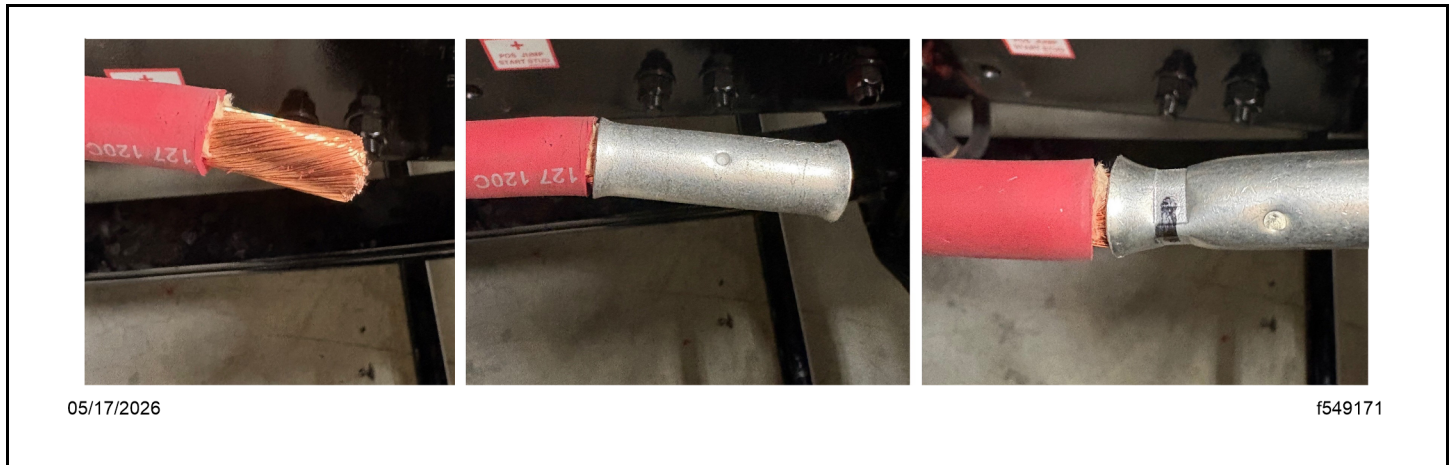

Fig 104, Installing and Crimping the Terminal

- a. Fully seat the conductor in the terminal.
 - b. Adjust the crimping tool to the correct cable size.
 - c. Position the crimping tool approximately 5/16 inch (8 mm) from the open end of the barrel. Crimp the terminal.
- NOTE:** To prevent the cable strands from entering the heat shrink over time, all the cable strands must be inserted into the terminal. If the cable strands are outside the barrel, wind them around the conductor in the gap between the cable insulation and the terminal. Apply electrical tape over the gap to prevent them from contacting the heat shrink layer.
21. Determine the length of the new jump-start cable (A66-12311-046).
 - a. Compare the old starter cable to the new jump-start cable.
 - b. Remove the tape securing the convolute cover to access the cable.
 - c. Hold the jump-start cable up to the mounting hole on the support bracket.
 - d. Feed the cable under the frame following the path of the other cable(s) to the starter. Mark the cable where it passes the base of the positive post on the starter.
 22. Adjust the length of the new jump-start cable. Replace the starter-end terminal.
 - a. Remove the tape securing the convolute cover on the cable, if present.
 - b. Cut the cable squarely at the length determined in step 21.
 - c. Position the new 4/0 diameter heat shrink sleeve (66-47062-000) on the cable.
 - d. Remove a minimum of 1.2 inch (32 mm) of the cable insulation without damaging the wire strands.
 - e. Straighten any bent strands of the conductor.
 - f. Fully seat the conductor in the terminal (23-13773-004).
 - g. Position the new terminal according to the orientation drawing. See Fig. [Fig. 105](#).

F1029 A-O

Creation Date: May 2026

NHTSA #26V-079

Transport Canada #2026-054

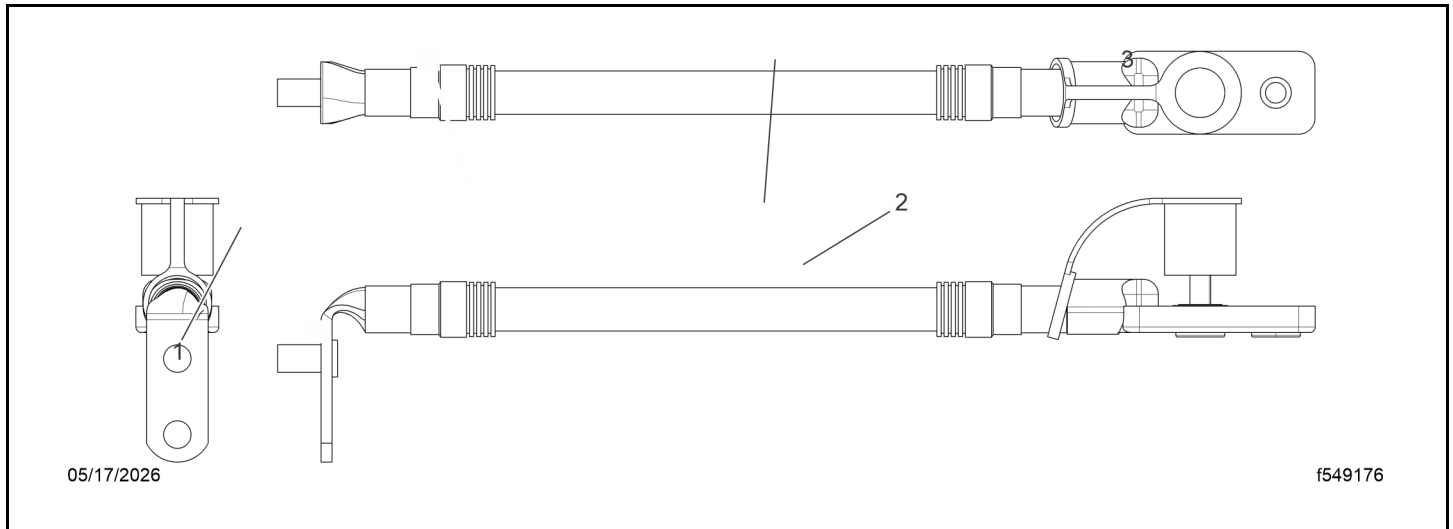

Fig 105, Jump-Start Cable Orientation

- h. Adjust the crimping tool to the correct cable size.
- i. Position the crimping tool approximately 3/8 inch (9 mm) from the open end of the barrel and crimp the terminal.

NOTE: If the new jump-start cable terminal does not fit over the conductor easily, deburr the inside diameter of the barrel opening.

NOTE: If the strands of the conductor are too frayed to fit into the terminal barrel, use a small cable tie to make two wraps around the conductor near the end of the insulation. Tighten the tie and push it towards the end of the conductor to compact the strands. Stop with enough remaining conductor to start the terminal, push it on, and remove the tie.

- 23. Apply heat shrink to the cable.
 - a. Slide the heat shrink into position on the terminal.
 - b. Activate the heat shrink sleeve by heating it evenly at one end until it adapts to the size of the terminal and the adhesive liquefies. Continue heating the sleeve on all sides, working from one end to the other.
 - c. Confirm a continuous ring of adhesive can be seen around the circumference of the sleeve at both ends. See Fig. [Fig. 106](#).

F1029 A-O

Creation Date: May 2026

NHTSA #26V-079

Transport Canada #2026-054

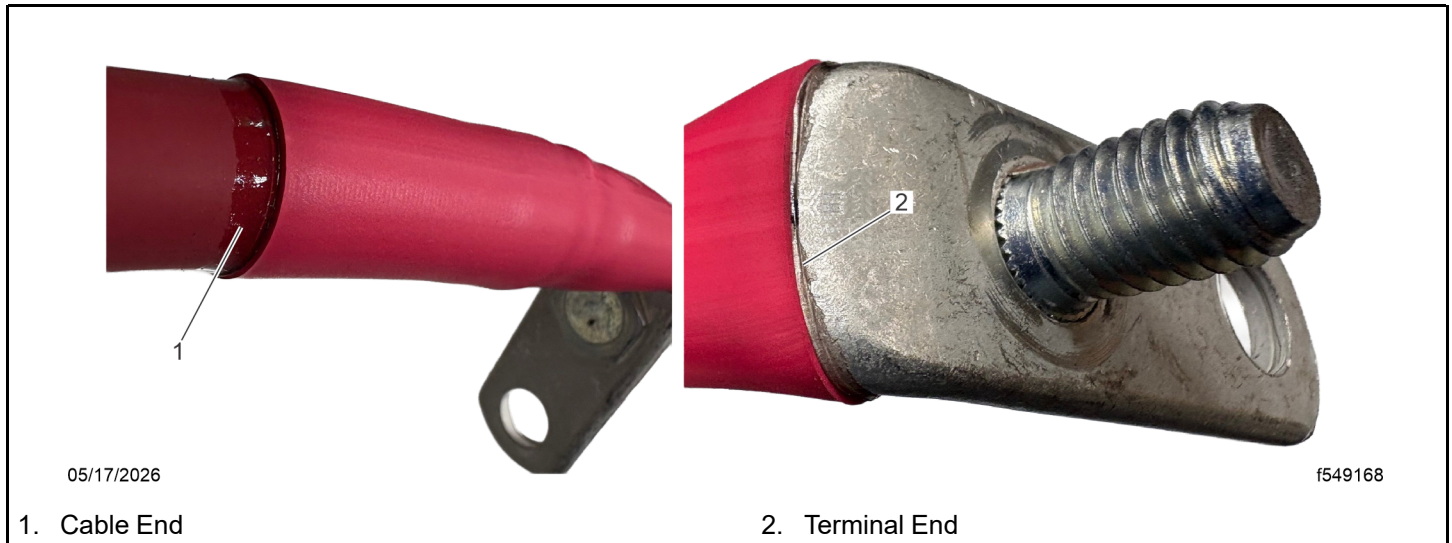

Fig 106, Continuous Adhesive Seal at Cable and Terminal Ends

- d. Install the convolute cover by applying red electrical tape to cover the transition from the heat shrink to the convolute cover. See Fig. [Fig. 107](#).

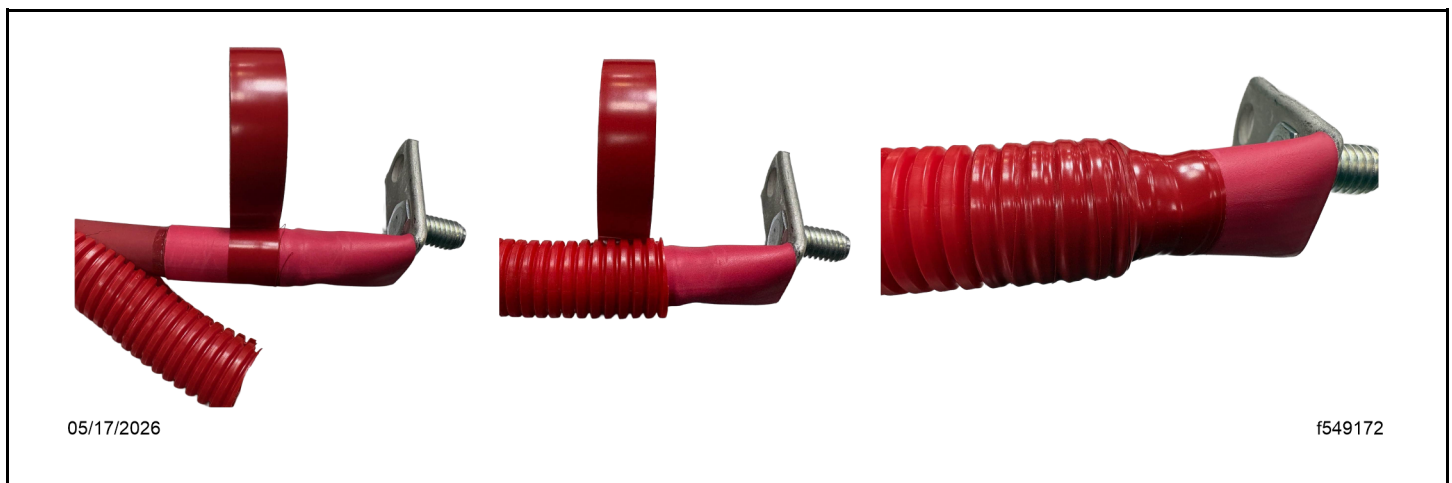

Fig 107, Installing the Convolute Cover

24. Install the convolute cover (48-25360-019) on the new auxiliary Battery Cable Access (BCA) cable (A06-35801-060).
 - a. Apply red electrical tape to cover the transition from the heat shrink to the convolute on the starter end of the cable.
 - b. From the starter end of the cable, add two tape rings at approximately 6 to 8 inch (150 to 200 mm) increments to secure the convolute to the cable. Leave the remaining cover loose until the butt connection has been made and sealed.

F1029 A-O

Creation Date: May 2026

NHTSA #26V-079

Transport Canada #2026-054

25. Assemble the new auxiliary BCA to the jump-start cable.
 - a. Position the auxiliary BCA cable end on the extra post of the jump-start cable to fit with the other cables on the starter. Ensure the two cables do not cross between the starter and the under-frame routing bracket. See Fig. [Fig. 108](#).



Fig 108, Assembled Jump-Start and BCA Cables

- b. Install the nut (23-09596-050) and washer (23-10900-050). Tighten the fasteners 19 lbf·ft (26 N·m).
26. Install the jump-start auxiliary BCA cable assembly on the starter. Tighten 19 lbf·ft (26 N·m).
27. Apply dielectric red enamel paint to the exposed surfaces of the cable ends at the starter.

F1029 A-O

Creation Date: May 2026

NHTSA #26V-079

Transport Canada #2026-054

28. Install the 5/8 inch (16 mm) tie block (23-13805-062) on the bottom isolator bracket frame bolt so the cable routing can be set passing by it. See Fig. [Fig. 109](#).

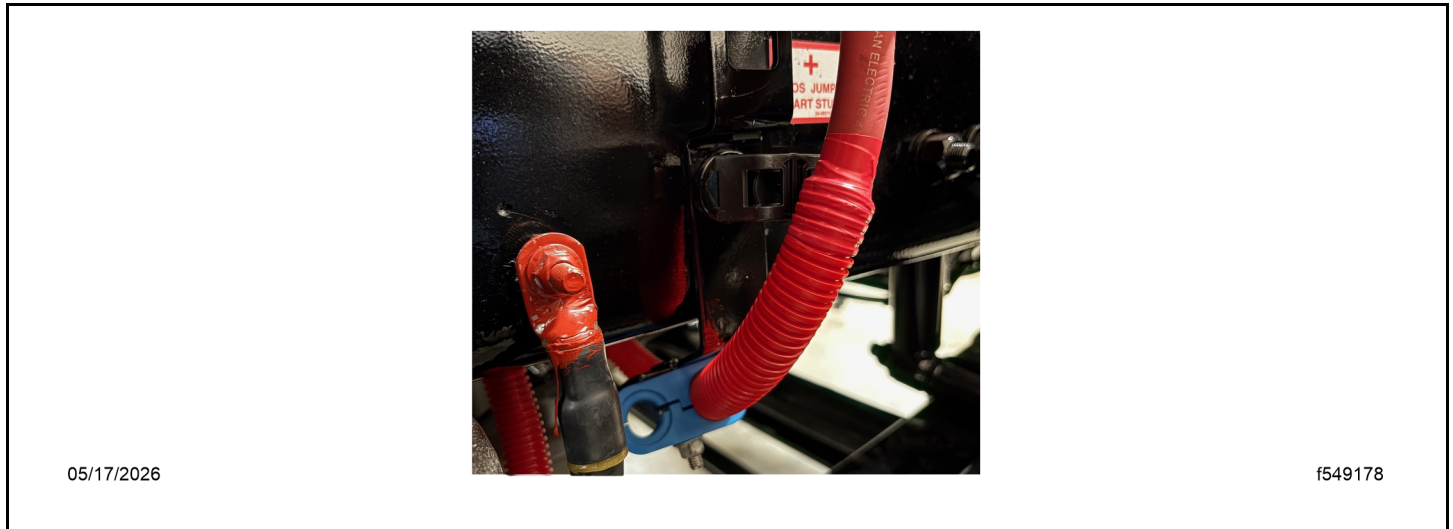

Fig 109, Routing Over the Tie Block

29. Route the jump-start/auxiliary BCA cables from the starter to the lower frame rail support bracket using the new routing clamps (23-14775-002) sized for 2/0 and 4/0 cables. See Fig. [Fig. 110](#).

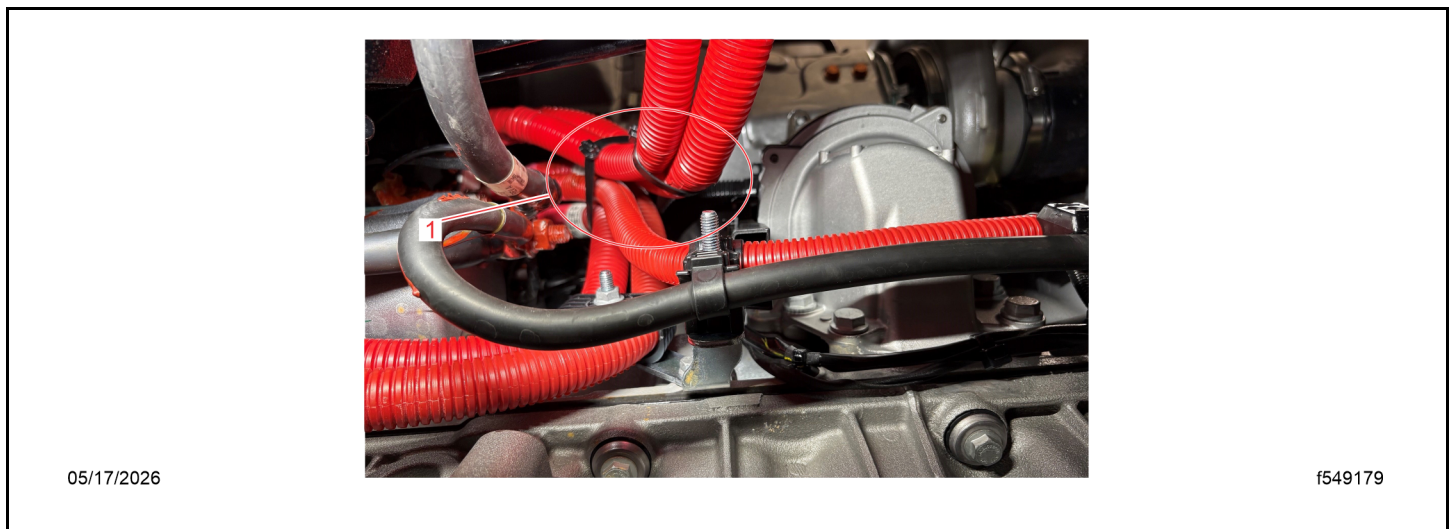

Fig 110, Securing the Cables

F1029 A-O

Creation Date: May 2026

NHTSA #26V-079

Transport Canada #2026-054

1. Secured Cables

30. Route the auxiliary jump-start/auxiliary BCA cables on the lower frame rail support bracket using the new routing clamps (23-14775-002) sized for 2/0 and 4/0 cables.

31.

NOTE: If the cables routing under the frame include a ground cable utilizing the one of the two routing clamp holes, route the 4/0 cables in the original clamps and butterfly the BCA cable along the path using butterfly ties (TYCDCT110HIR).

Route the jump-start cable to the support bracket and the bolt (N910105 008016), cable, washer (23-10900-038), and nut (23-12612-008). Hand-tighten the fasteners.

32. Remove the 5/8" tie block and tighten the frame bolts that secure the isolator bracket to the frame rail to 148 lbf·ft (200 N·m). See Fig. [Fig. 111](#).



Fig 111, Jump-Start Cable Support Bracket

33. If required, apply touch-up paint to the frame bolts.
34. Install the 5/8" tie block (23-13805-062) on the bottom of the isolator bracket frame bolt.

F1029 A-O

Creation Date: May 2026

NHTSA #26V-079

Transport Canada #2026-054

35. Determine the ideal length for the new auxiliary BCA cable between the starter and butt connector. Cut the cable. See Fig. Fig. 112.

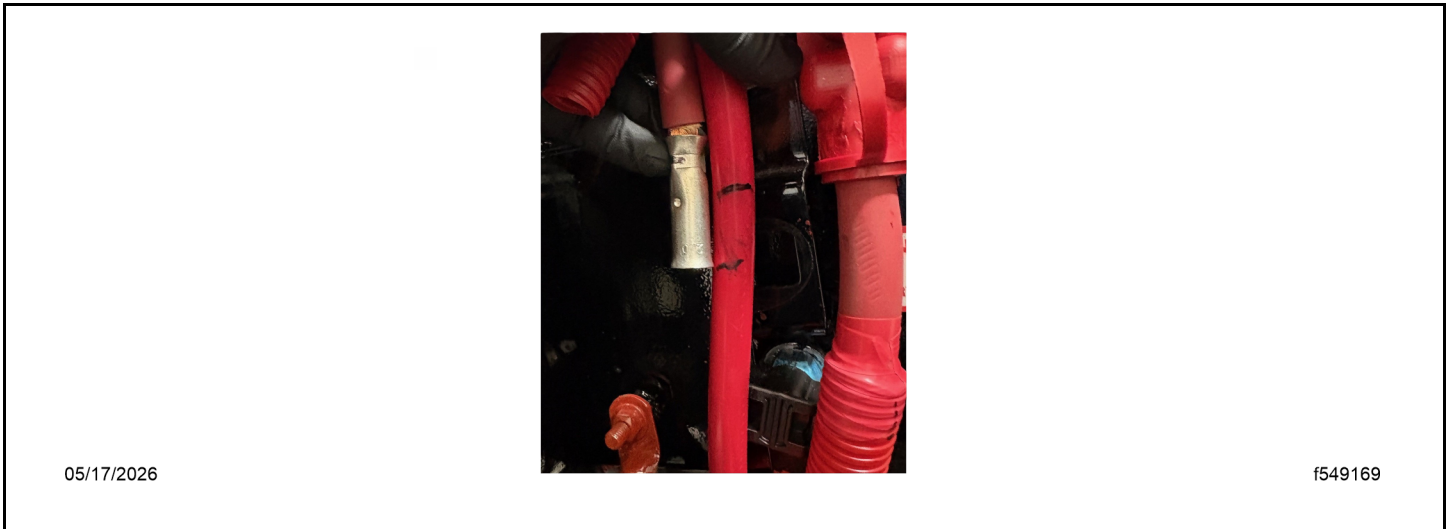

Fig 112, Determining the BCA Cable Length

36. Position three pieces of heat shrink tubing (66-47062-001) on the auxiliary BCA cable with one on the upper cable and two on the lower cable.
- NOTE:** Position the heat shrink tube to allow enough room to complete the butt crimp process without damaging it. If the heat shrink is damaged and splits during the heating process, the terminal must be replaced to ensure the connection is watertight.
37. Crimp the butt connector.
- Remove the cable insulation equal to half the butt connector length without damaging the wire strands.
 - Straighten any bent conductor strands.
 - Fully seat the conductor in the terminal.
 - Adjust the crimping tool to the correct cable size.
 - Crimp the terminal.

F1029 A-O

Creation Date: May 2026

NHTSA #26V-079

Transport Canada #2026-054

38. Insulate the butt connection with heat shrink sleeves. See Fig. Fig. 113.

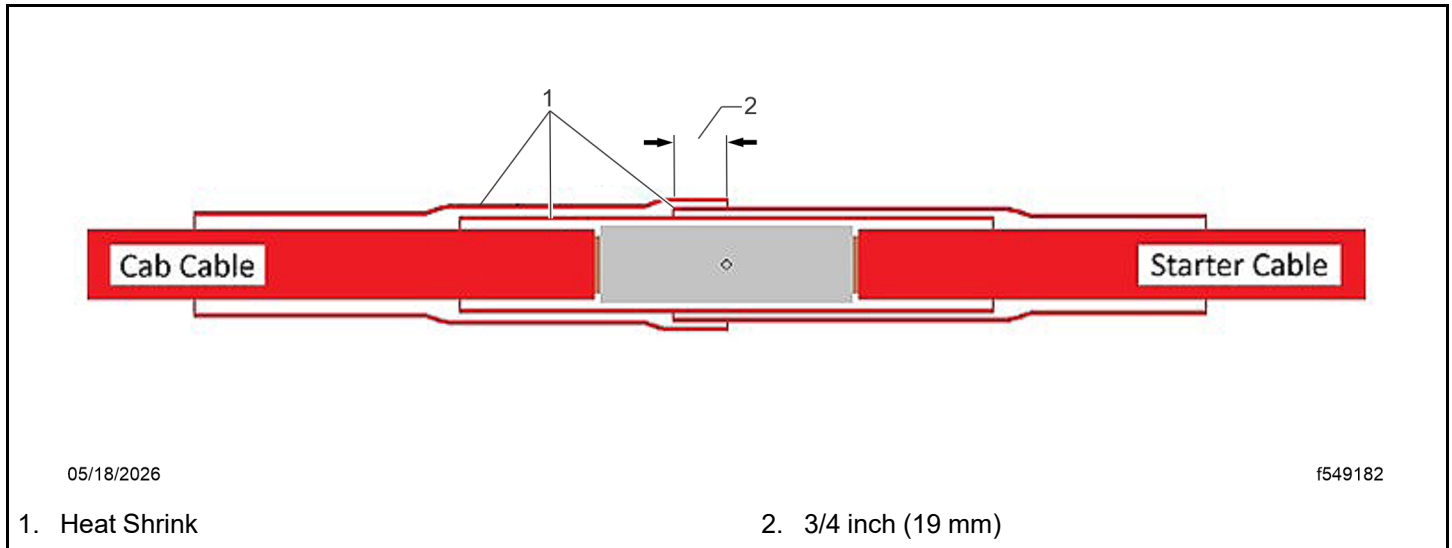

Fig 113, Heat Shrink Insulation

- a. Center the first piece of heat shrink sleeve on the terminal.
 - b. Activate the sleeve by heating it evenly from one end until it adapts to the size of the cable and the adhesive liquefies.
 - c. Continue heating the sleeve on all sides, working from one end to the other.
 - d. Confirm a continuous ring of adhesive can be seen around the circumference of the sleeve at both ends.
 - e. Position the second sleeve on the lower cable and overlap the center of the first sleeve by 3/4 inch (19 mm).
 - f. Activate the second sleeve by heating it evenly from one end until it adapts to the size of the cable and the adhesive liquefies.
 - g. Continue heating the second sleeve on all sides, working from one end to the other.
 - h. Confirm a continuous ring of adhesive can be seen around the circumference of the second sleeve at both ends.
 - i. Position the third sleeve on the upper cable and overlap the top of the second sleeve by 3/4 inch (19 mm).
 - j. Activate the third sleeve and inspect for a continuous ring of sealant at both ends.
39. Cover the heat shrink joint with convolute tubing. If extra convolute tubing is required, use 4/0 Red Slit Convolute (48-25360-022) for 4/0 cables, and CONDUIT-NYL, 19MM, FLEX (48-25360-019) for 2/0 cables.
40. Apply red electrical tape to the cable and to the convolute end to create a seamless transition between the ends of the convolute.

F1029 A-O

Creation Date: May 2026

NHTSA #26V-079

Transport Canada #2026-054

41. Install the upper and lower cable clamps on the isolator frame bracket. To prevent cables (A) from rubbing, secure any cables routed on the outside cable clamps (B) using butterfly cable ties (C) (TYCDCT110HIR). See Fig. **Fig. 114**.

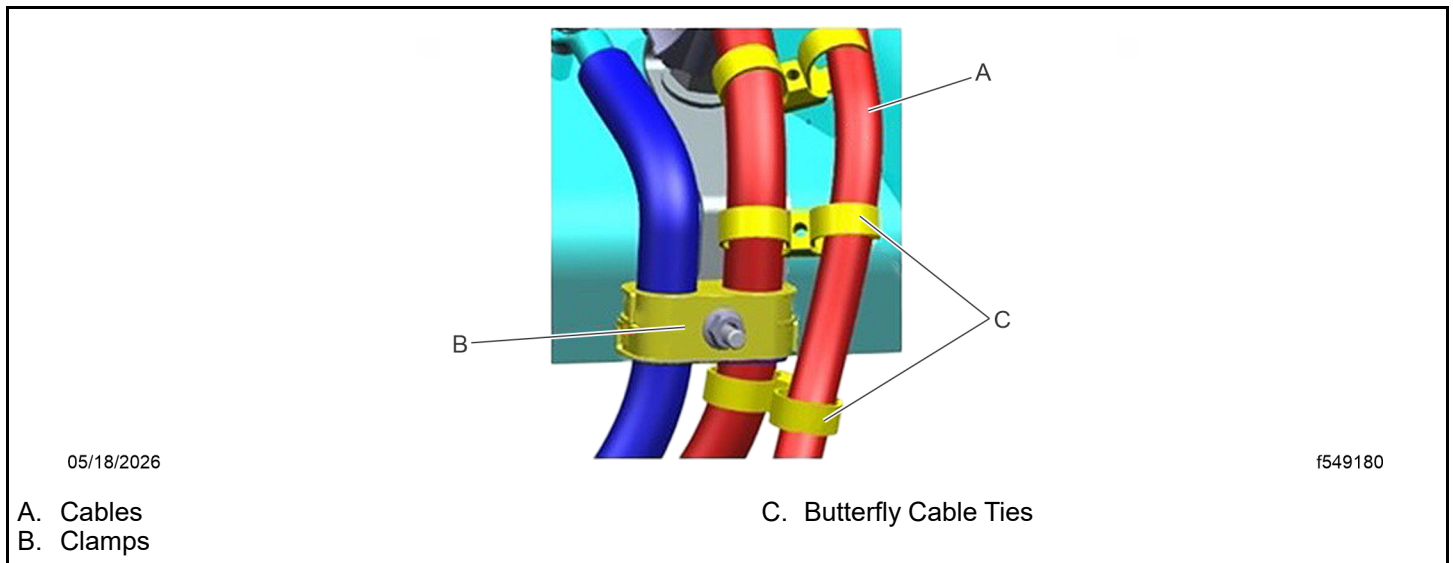

Fig 114, Butterfly Cable Ties Around the Cable Clamps

42. Secure the cables to the 5/8 inch (16 mm) tie block with a Heavy Duty (HD) cable tie (23-13476-000) and other points where positive power cables are routed together.
43. Use butterfly cable ties (TYCDCT110HIR) to route positive cables next to any other cables or anywhere along the path where cables must be separated.
IMPORTANT: Ensure no power cables are rubbing, or close to rubbing, the frame or engine components.
44. Remove the nut that secures the jump-start cable to the support bracket. Apply medium strength thread locker. Install the nut and tighten 14 lbf·ft (19 N·m).

F1029 A-O

Creation Date: May 2026

NHTSA #26V-079

Transport Canada #2026-054

45. Install the nylon nut (23-13379-001) on the tail of the bolt that secures the jump-start cable to the support bracket (1). Tighten the nut 7 lbf·ft (9.5 N·cm). See Fig. **Fig. 115**.



Fig 115, Nylon Nut on Jump-Start Bracket Fastener

1. Nylon Nut
46. If removed, install the splash shield behind the front tire. For detailed instructions, see Group 88 of the *47X, 48X and 49X Workshop Manual*.
47. Install the negative cable connections at the batteries.
48. Clean a spot on the base label (Form WAR259) and attach a campaign completion sticker for F1029 (Form WAR260).

F1029 A-O

Creation Date: May 2026

NHTSA #26V-079

Transport Canada #2026-054

Group J Work Instructions

1. Check the base label (Form WAR259) for a completion sticker for F1029 (Form WAR260), indicating this work has been done. The base label is usually located on the passenger-side door, about 12 inches (30 cm) below the door latch. If a completion sticker is present, no work is needed. If a completion sticker is not present, proceed to the next step.
2. Park the vehicle on a level surface and set the parking brake. Chock the rear tires.
3. Turn the steer wheels to the right side to make the isolated stud accessible. Shut down the engine.
4. Open the hood.
5. Locate the isolated positive (+) battery stud mounted on the frame behind the front wheel. See Fig. [Fig. 116](#).

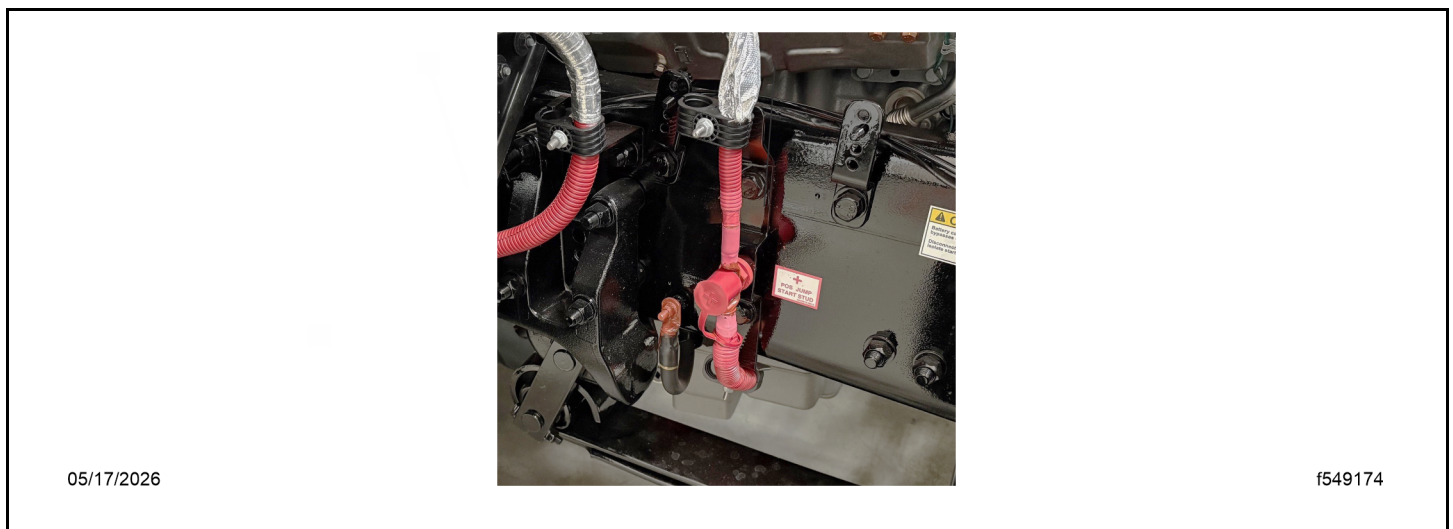

Fig 116, Isolated Battery Junction with Jump-Start Post

6. Remove the negative (-) cable connection(s) from the batteries.
7. If required for access, remove the splash shield from behind the front tire. For detailed instructions, see Group 88 of the *47X, 48X and 49X Workshop Manual*.
8. Remove the jump-start post or nut that secures the battery cable(s) to the isolated stud.
9. Remove the clamp(s) that secure the positive battery cables to the clipping point above the frame rail.
10. Remove the clamp(s) and ties that secure the positive battery cable routed between the isolated stud and the starter.
11. Remove the nut that secures the positive battery cables to the starter.
12. Remove the cable that connects the isolated stud to the starter.
13. Remove the bolt securing the lower cable routing bracket to the frame.
14. Fit the jump-start cable bracket (12-25410-000), washer, and cable routing bracket on the frame bolt. Install the assembly in the frame hole.

F1029 A-O

Creation Date: May 2026

NHTSA #26V-079

Transport Canada #2026-054

15. Install the frame fastener nut. Tighten to allow the brackets to remain loose.
16. Position the jump-start support bracket bolt (N910105 008016) in the bracket.
NOTE: The bolt that secures the jump-start cable to the support bracket may be too long to be installed when the frame bolt is tight. It should be positioned in the bracket hole before tightening the frame bolt.
17. Align the routing and jump-start support brackets vertically on the frame. Tighten the frame bolt to 148 lbf-ft (200 N·m).
18. Remove the isolated stud bracket from the frame.
19. Remove the stud from the bracket.
20. Install the isolated stud bracket.
 - a. Find the frame bolt closest to the square stud mounting hole and position that bolt with the head on the inboard side of the frame.
 - b. Fit the routing bracket and washer. Tighten the nut by hand.
 - c. Install the second frame bolt with the head on the outboard side of the frame.
 - d. Tighten both bolts to 148 lbf-ft (200 N·m).
21. If required, apply touch-up paint to the frame bolts.
22. Remove the ring terminal from the positive cable that is routed to the cab.
 - a. Note how the cables are secured and remove wire ties, tape, and convolute, as needed to uncover at least 6 inches of the cable.
 - b. Remove the original heat shrink. To do so, heat it, score it, and continue to heat it until the score splits and the adhesive softens. See Fig. [Fig. 117](#).

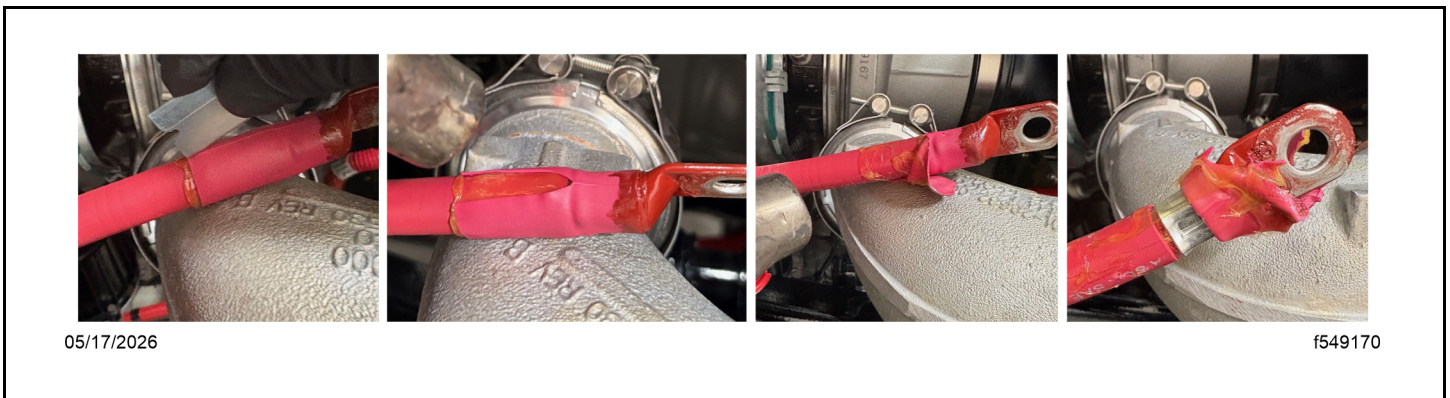

Fig 117, Heat Shrink Removal

- c. Cut the cable just above the ring terminal.
- d. Remove the cable insulation equal to half the butt connector length without damaging the wire strands. See Fig. [Fig. 118](#).

F1029 A-O

Creation Date: May 2026

NHTSA #26V-079

Transport Canada #2026-054



Fig 118, Removing the Insulation

- e. Straighten any bent strands of the conductor.

NOTE: To ensure proper crimp force is applied to the terminal, the cable cuts must be square and the number of damaged or lost strands must be minimized.

- 23. Inspect the conductors for evidence of corrosion. Is corrosion present on either of the newly exposed conductors?

NOTE: The cable must be replaced if cutting back the corrosion causes the cable to become too short for the butt terminal to be supported by the routing clamp above the frame rail.

- a. **YES** → Cut off about 1 inch (25 mm) of cable. Repeat steps 22d to 22e to remove the cable insulation. Evaluate the condition of the conductor.
- b. **NO** → Go to step 24.

F1029 A-O

Creation Date: May 2026

NHTSA #26V-079

Transport Canada #2026-054

24. Crimp the butt connector terminal (PHM 8 2960 and PHM 8 2960) on the cable routed to the cab. See Fig. [Fig. 119](#).

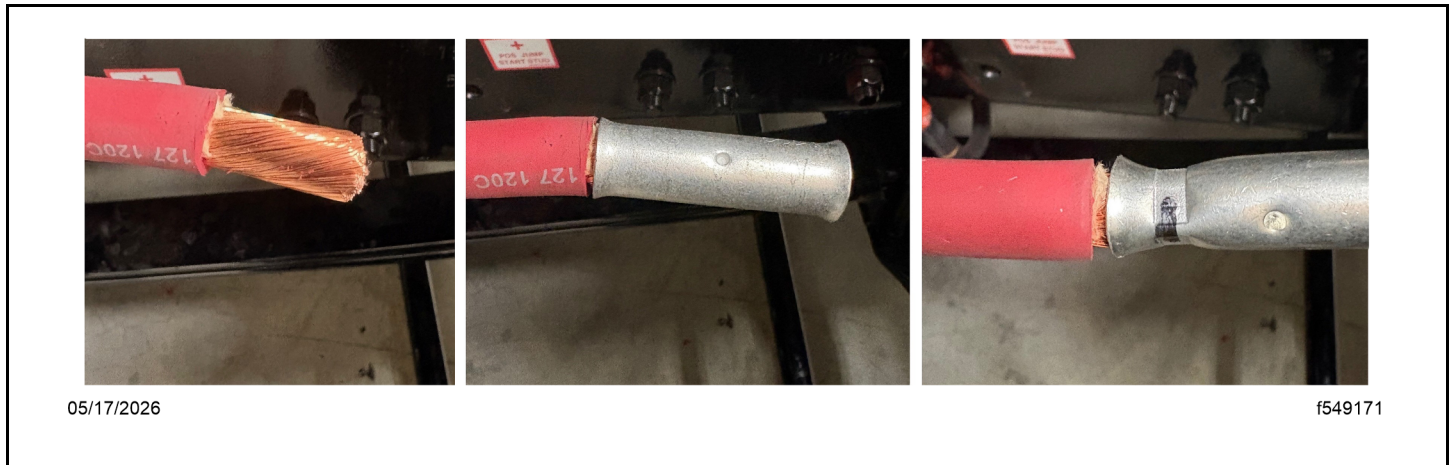

Fig 119, Installing and Crimping the Terminal

- a. Fully seat the conductor in the terminal.
 - b. Adjust the crimping tool to the correct cable size.
 - c. Position the crimping tool approximately 5/16 inch (8 mm) from the open end of the barrel. Crimp the terminal.
- NOTE:** To prevent the cable strands from entering the heat shrink over time, all the cable strands must be inserted into the terminal. If the cable strands are outside the barrel, wind them around the conductor in the gap between the cable insulation and the terminal. Apply electrical tape over the gap to prevent them from contacting the heat shrink layer.
25. Determine the length of the new jump-start cable (A66-12311-046).
- a. Compare the old starter cable to the new jump-start cable.
 - b. Remove the tape securing the convolute cover to access the cable.
 - c. Hold the jump-start cable up to the mounting hole on the support bracket.
 - d. Feed the cable under the frame following the path of the other cable(s) to the starter. Mark the cable where it passes the base of the positive post on the starter.
26. Adjust the length of the new jump-start cable. Replace the starter-end terminal.
- a. Remove the tape securing the convolute cover on the cable, if present.
 - b. Cut the cable squarely at the length determined in step 21.
 - c. Position the 4/0 diameter heat shrink sleeve (66-47062-000) on the cable.
 - d. Remove a minimum of 1.2 inch (32 mm) of the cable insulation without damaging the wire strands.
 - e. Straighten any bent strands of the conductor.
 - f. Fully seat the conductor in the terminal (23-13773-004).
 - g. Position the new terminal according to the orientation drawing. See Fig. [Fig. 120](#).

F1029 A-O

Creation Date: May 2026

NHTSA #26V-079

Transport Canada #2026-054

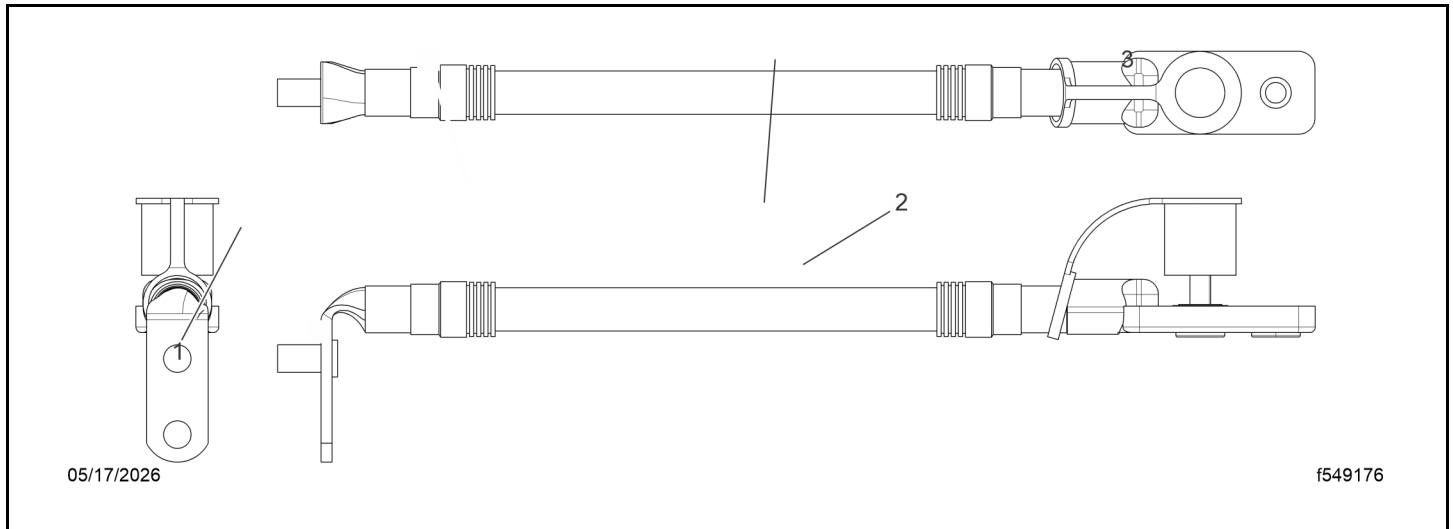

Fig 120, Jump-Start Cable Orientation

- h. Adjust the crimping tool to the correct cable size.
- i. Position the crimping tool approximately 3/8 inch (9 mm) from the open end of the barrel and crimp the terminal.

NOTE: If the new jump-start cable terminal does not fit over the conductor easily, deburr the inside diameter of the barrel opening.

NOTE: If the strands of the conductor are too frayed to fit into the terminal barrel, use a small cable tie to make two wraps around the conductor near the end of the insulation. Tighten the tie and push it towards the end of the conductor to compact the strands. Stop with enough remaining conductor to start the terminal, push it on, and remove the tie.

- 27. Apply heat shrink to the cable.
 - a. Slide the heat shrink into position on the terminal.
 - b. Activate the heat shrink sleeve by heating it evenly at one end until it adapts to the size of the terminal and the adhesive liquefies. Continue heating the sleeve on all sides, working from one end to the other.
 - c. Confirm a continuous ring of adhesive can be seen around the circumference of the sleeve at both ends. See Fig. [Fig. 121](#).

F1029 A-O

Creation Date: May 2026

NHTSA #26V-079

Transport Canada #2026-054

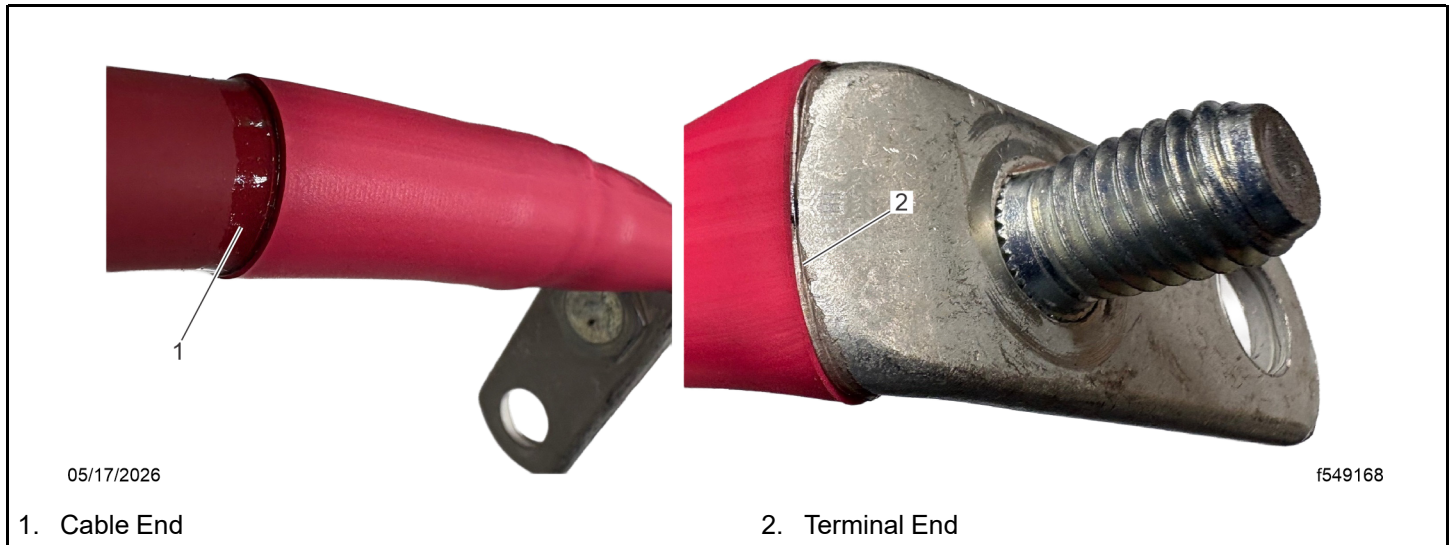

Fig 121, Continuous Adhesive Seal at Cable and Terminal Ends

- d. Install the convolute cover by applying red electrical tape to cover the transition from the heat shrink to the convolute cover. See Fig. [Fig. 122](#).

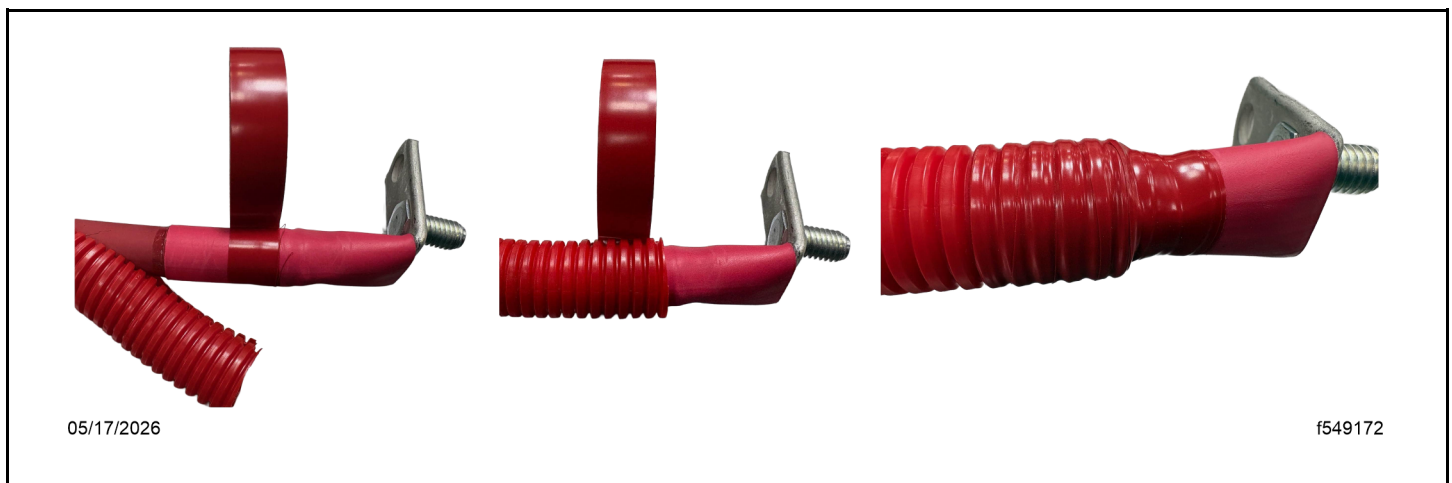

Fig 122, Installing the Convolute Cover

28. Install the convolute cover (48-25360-019) on the new auxiliary Battery Cable Access (BCA) cable (A06-35801-060).
 - a. Apply red electrical tape to cover the transition from the heat shrink to the convolute on the starter end of the cable.
 - b. From the starter end of the cable, add two tape rings at approximately 6 to 8 inch (150 to 200 mm) increments to secure the convolute to the cable. Leave the remaining cover loose until the butt connection has been made and sealed.

F1029 A-O

Creation Date: May 2026

NHTSA #26V-079

Transport Canada #2026-054

29. Assemble the new auxiliary BCA to the jump-start cable. See Fig. [Fig. 123](#).



Fig 123, Assembled Jump-Start and BCA Cables

- a. Position the auxiliary BCA cable end on the extra post of the jump-start cable to fit with the other cables on the starter. Ensure the two cables do not cross between the starter and the under-frame routing bracket.
 - b. Install the nut (23-09596-050) and washer (23-10900-050). Tighten the fasteners 19 lbf·ft (26 N·m).
30. Install the jump-start auxiliary BCA cable assembly on the starter. Tighten 19 lbf·ft (26 N·m).
31. Apply dielectric red enamel paint to the exposed surfaces of the cable ends at the starter.

F1029 A-O

Creation Date: May 2026

NHTSA #26V-079

Transport Canada #2026-054

32. Route the jump-start auxiliary BCA cables next to the other heavy positive cable(s) from the starter to the lower frame rail support bracket. See Fig. [Fig. 124](#).

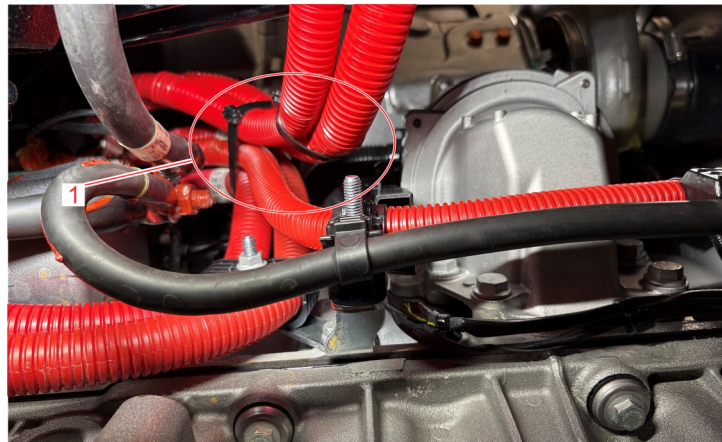

05/17/2026

f549179

Fig 124, Securing the Cables

33.

NOTE: If the cables routing under the frame include a ground cable utilizing the one of the two routing clamp holes, route the 4/0 cables in the original clamps and butterfly the BCA cable along the path using butterfly ties (TYCDCT110HIR).

Route the auxiliary jump-start/auxiliary BCA cables on the lower frame rail support bracket using the new routing clamps (23-14775-002) sized for 2/0 and 4/0 cables.

34. Route the jump-start cable to the support bracket. Fit the cable and washer (23-10900-038). Apply medium strength thread locker. Tighten the nut (23-12612-008) to 14 lbf·ft (19 N·m).

F1029 A-O

Creation Date: May 2026

NHTSA #26V-079

Transport Canada #2026-054

35. Install the nylon nut (23-13379-001) on the tail of the bolt holding the jump-start cable to the support bracket. Tighten 7lbf·ft (9.5 N·m). See Fig. [Fig. 125](#).



Fig 125, Nylon Nut on Jump-Start Bracket Fastener

1. Nylon Nut

36. Determine the ideal length for the new auxiliary BCA cable between the starter and butt connector. Cut the cable. See Fig. [Fig. 126](#).

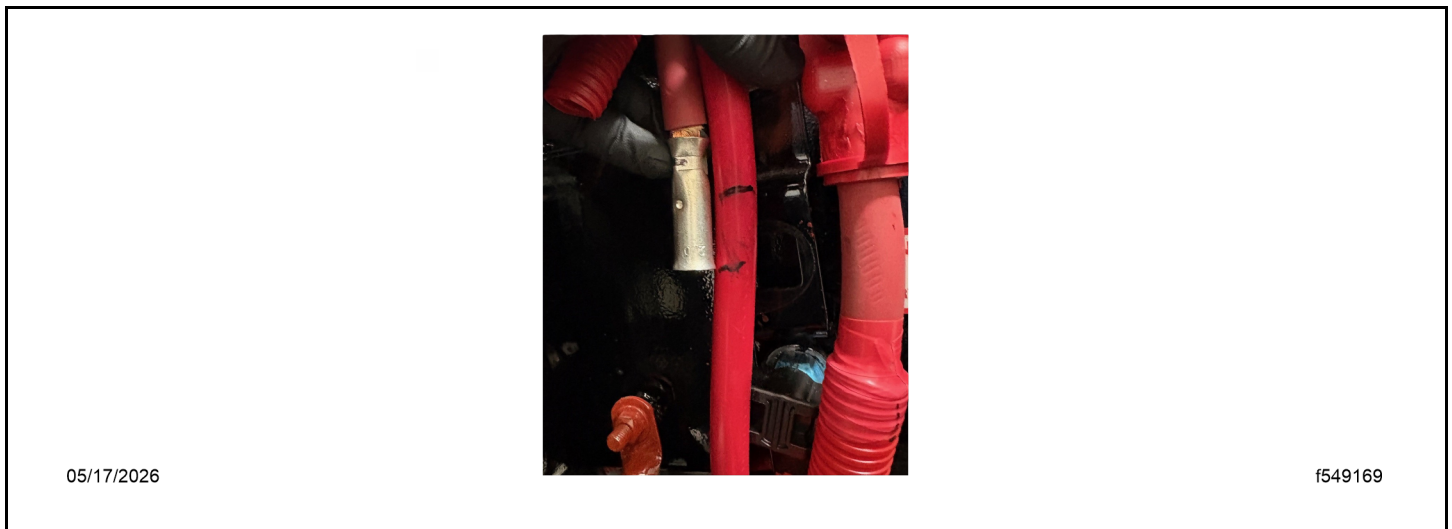

Fig 126, Determining the BCA Cable Length

F1029 A-O

Creation Date: May 2026

NHTSA #26V-079

Transport Canada #2026-054

37. Position three pieces of heat shrink tubing (66-47062-001) on the auxiliary BCA cable with one on the upper cable and two on the lower cable. Position three pieces of heat shrink tubing (66-47062-000) on the starter cable with one on each upper cable and two on each lower cable.

NOTE: Position the heat shrink tube to allow enough room to complete the butt crimp process without damaging it. If the heat shrink is damaged and splits during the heating process, the terminal must be replaced to ensure the connection is watertight.

38. Crimp the butt connector.
- Remove the cable insulation equal to half the butt connector length without damaging the wire strands.
 - Straighten any bent conductor strands.
 - Fully seat the conductor in the terminal.
 - Adjust the crimping tool to the correct cable size.
 - Crimp the terminal.
 - Activate the third sleeve and inspect for a continuous ring of sealant at both ends.

39. Insulate the butt connection with heat shrink sleeves. See Fig. [Fig. 127](#).

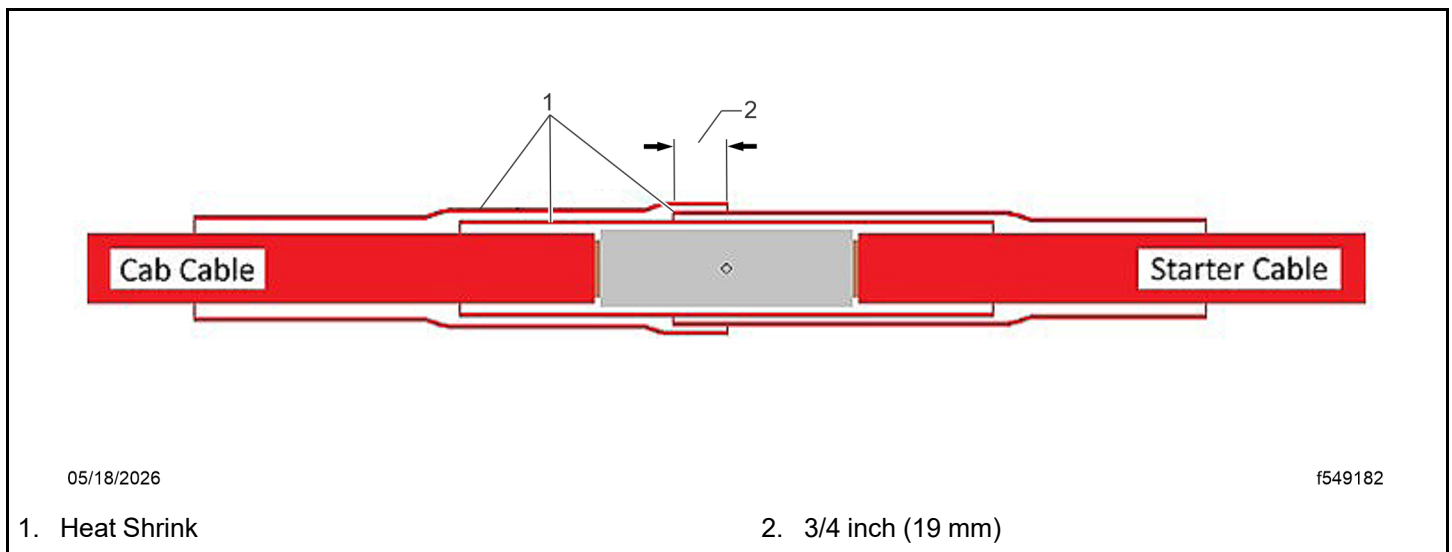

Fig 127, Heat Shrink Insulation

- Center the first piece of heat shrink sleeve on the terminal.
- Activate the sleeve by heating it evenly from one end until it adapts to the size of the cable and the adhesive liquefies.
- Continue heating the sleeve on all sides, working from one end to the other.
- Confirm a continuous ring of adhesive can be seen around the circumference of the sleeve at both ends.
- Position the second sleeve on the lower cable and overlap the center of the first sleeve by 3/4 inch (19 mm).

F1029 A-O

Creation Date: May 2026

NHTSA #26V-079

Transport Canada #2026-054

- f. Activate the second sleeve by heating it evenly from one end until it adapts to the size of the cable and the adhesive liquefies.
 - g. Continue heating the second sleeve on all sides, working from one end to the other.
 - h. Confirm a continuous ring of adhesive can be seen around the circumference of the second sleeve at both ends.
 - i. Position the third sleeve on the upper cable and overlap the top of the second sleeve by 3/4 inch (19 mm).
40. Cover the heat shrink joint with convolute tubing. If extra convolute tubing is required, use 4/0 Red Slit Convolute (48-25360-022) for 4/0 cables, and CONDUIT-NYL,19MM,FLEX (48-25360-019) for 2/0 cables.
 41. Apply red electrical tape to the cable and then to the convolute end to create a seamless transition between the ends of the convolute.
 42. Install the 5/8" routing block (23-13805-062) on the frame bolt for the isolated stud bracket with the threads on the outside of the frame.
 43. Install the upper and lower cable clamps on the isolator frame bracket. See Fig. [Fig. 128](#).

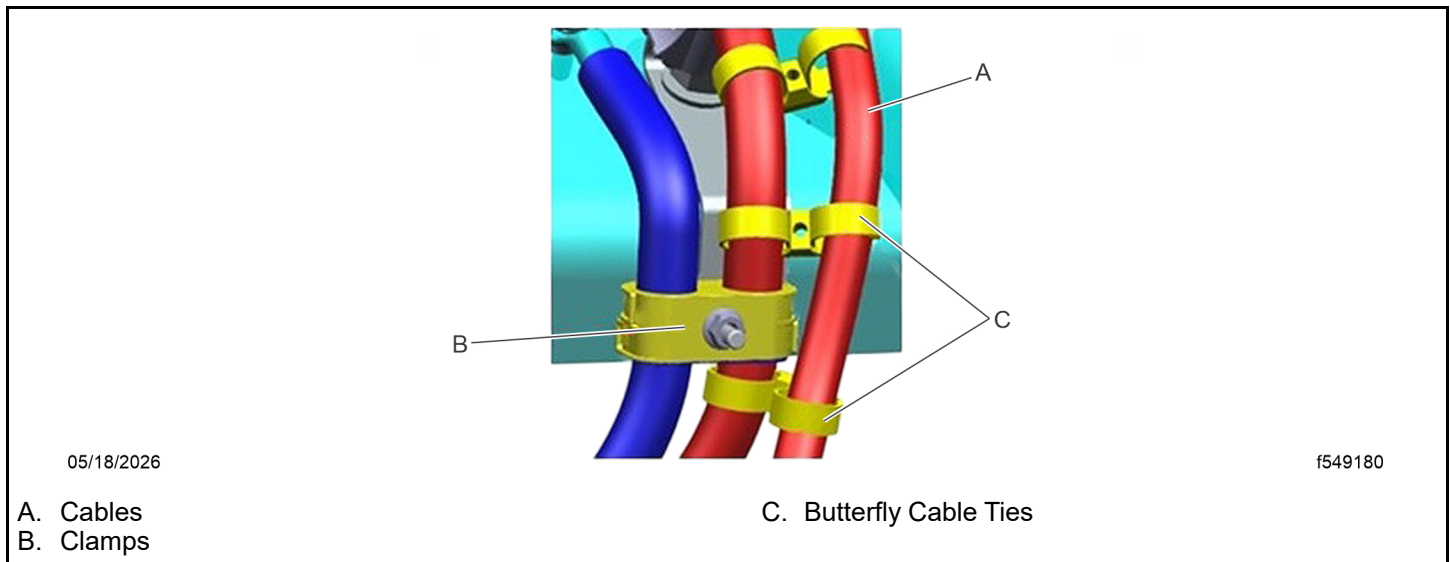

Fig 128, Butterfly Cable Ties Around the Cable Clamps

NOTE: If there are cables are routed on outside of the cable clamps, use butterfly cable ties to prevent them from rubbing.

44. Secure the cables with a Heavy Duty (HD) cable tie (23-13476-000) along the path where positive power cables are routed together.
45. Use butterfly cable ties (TYCDCT110HIR) to route positive cables next to any other cables or anywhere along the path where cables must be separated.

IMPORTANT: Ensure no power cables are rubbing, or close to rubbing, the frame or engine components.

F1029 A-O

Creation Date: May 2026

NHTSA #26V-079

Transport Canada #2026-054

46. If removed, install the splash shield behind the front tire. For detailed instructions, see Group 88 of the *47X, 48X and 49X Workshop Manual*.
47. Install the negative cable connections at the batteries.
48. Clean a spot on the base label (Form WAR259) and attach a campaign completion sticker for F1029 (Form WAR260).

F1029 A-O

Creation Date: May 2026

NHTSA #26V-079

Transport Canada #2026-054

Group K Work Instructions

1. Check the base label (Form WAR259) for a completion sticker for F1029 (Form WAR260), indicating this work has been done. The base label is usually located on the passenger-side door, about 12 inches (30 cm) below the door latch. If a completion sticker is present, no work is needed. If a completion sticker is not present, proceed to the next step.
2. Park the vehicle on a level surface and set the parking brake. Chock the rear tires.
3. Turn the steer wheels to the right side to make the isolated stud accessible. Shut down the engine.
4. Open the hood.
5. Locate the isolated positive (+) battery stud mounted on the frame behind the front wheel. See Fig. [Fig. 129](#).

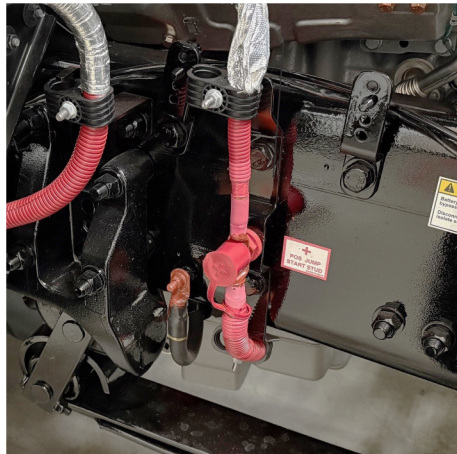

05/17/2026

f549174

Fig 129, Isolated Battery Junction with Jump-Start Post

6. Remove the negative (-) cable connection(s) from the batteries.
7. If required for access, remove the splash shield from behind the front tire. For detailed instructions, see Group 88 of the *47X, 48X and 49X Workshop Manual*.
8. Remove the jump-start post or nut that secures the battery cable(s) to the isolated stud.
9. Remove the clamp(s) that secure the positive battery cables to the clipping point above the frame rail.
10. Remove the clamp(s) and ties that secure the positive battery cable routed between the isolated stud and the starter.
11. Remove the nut that secures the positive battery cables to the starter.
12. Remove the cable that connects the isolated stud to the starter.
13. Remove the bolts that secure the isolated stud bracket to the frame.
14. Remove the isolated stud from the frame bracket.
15. Fit the lower isolator bracket frame bolt in position with the head on the inboard side of the frame.

F1029 A-O

Creation Date: May 2026

NHTSA #26V-079

Transport Canada #2026-054

16. Install the upper isolator bracket frame bolt with the head on the outside of the frame. Tighten both bolts 148 lbf·ft (200 N·m).
17. Remove the top bolt from the frame mounted routing and clipping bracket in front of the isolated stud bracket.
18. Install the new jump-start cable bracket (12-25410-000) on the clipping bracket frame bolt, followed by the washer. Position the assembly in the frame hole. Hand-tighten the fasteners to keep the bracket in position.
19. Remove the ring terminal from the positive cables that are routed to the cab.
 - a. Note how the cable is secured and remove wire ties, tape, and convolute, as needed to uncover at least 6 inches of the cable.
 - b. Remove the original heat shrink. To do so, heat it, score it, and continue to heat it until the score splits and the adhesive softens. See Fig. [Fig. 130](#).

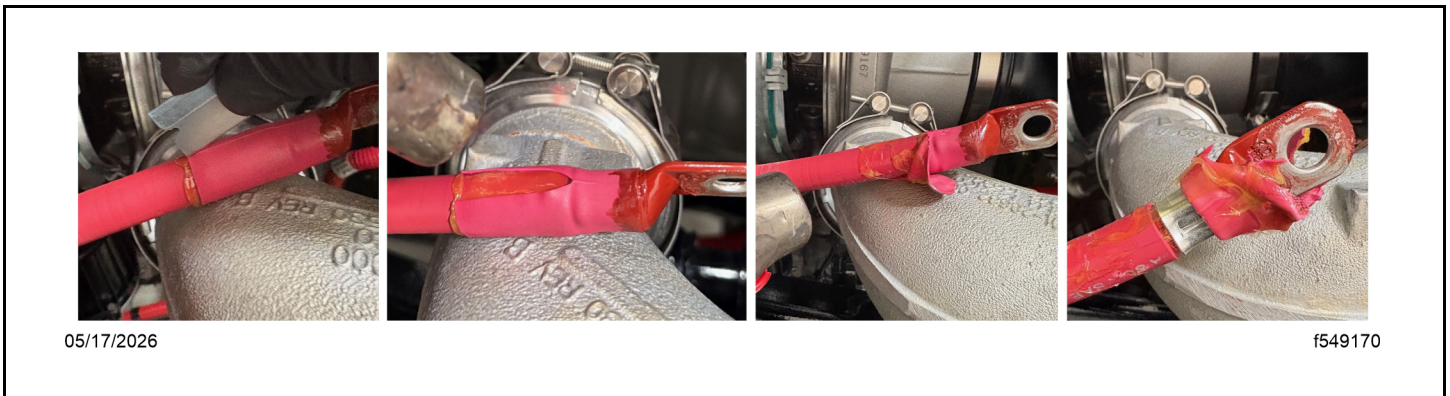

Fig 130, Heat Shrink Removal

- c. Cut the cable just above the ring terminal.
- d. Remove the cable insulation equal to half the butt connector length without damaging the wire strands. See Fig. [Fig. 131](#).

F1029 A-O

Creation Date: May 2026

NHTSA #26V-079

Transport Canada #2026-054



Fig 131, Removing the Insulation

e. Straighten any bent strands of the conductor.

NOTE: To ensure proper crimp force is applied to the terminal, the cable cuts must be square and the number of damaged or lost strands must be minimized.

20. Inspect the conductors for evidence of corrosion. Is corrosion present on either of the newly exposed conductors?

NOTE: The cable must be replaced if cutting back the corrosion causes the cable to become too short for the butt terminal to be supported by the routing clamp above the frame rail.

a. **YES** → Cut off about 1 inch (25 mm) of cable. Repeat steps 19d to 19e to remove the cable insulation. Evaluate the condition of the conductor.

b. **NO** → Go to step 21.

F1029 A-O

Creation Date: May 2026

NHTSA #26V-079

Transport Canada #2026-054

21. Crimp the butt connector terminal (PHM 8 2960) on the cable going to the cab. See Fig. [Fig. 132](#).

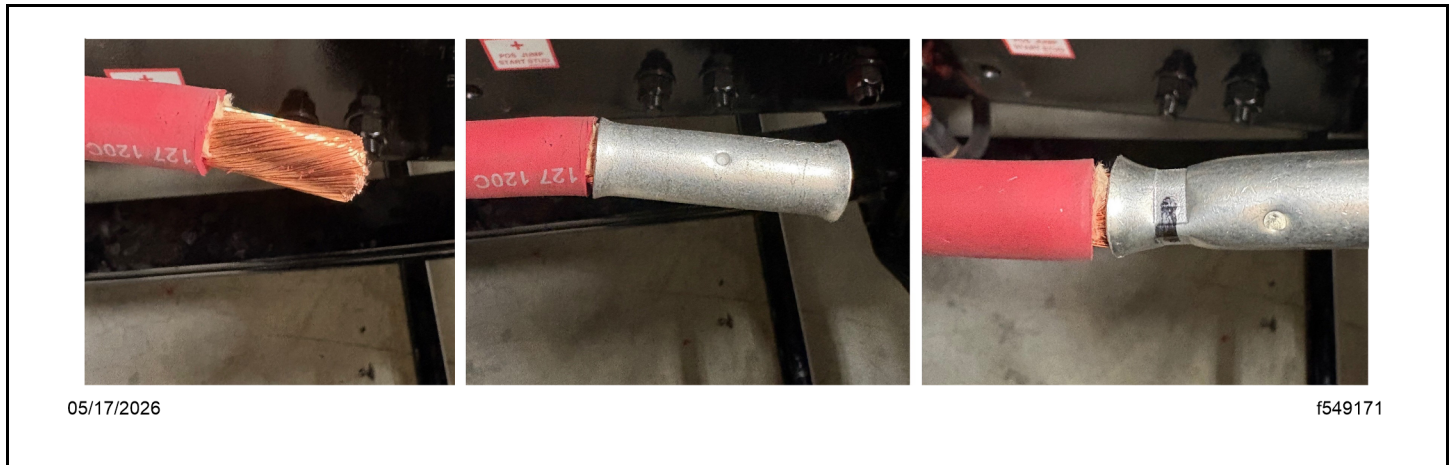

Fig 132, Installing and Crimping the Terminal

- a. Fully seat the conductor in the terminal.
 - b. Adjust the crimping tool to the correct cable size.
 - c. Position the crimping tool approximately 5/16" (8 mm) from the open end of the barrel and crimp the terminal.
- NOTE:** To prevent the cable strands from entering the heat shrink over time, all the cable strands must be inserted into the terminal. If the cable strands are outside the barrel, wind them around the conductor in the gap between the cable insulation and the terminal. Apply electrical tape over the gap to prevent them from contacting the heat shrink layer.
22. Determine the length of the new jump-start cable (A66-12311-046).
- a. Compare the old starter cable to the new jump-start cable.
 - b. Remove the tape securing the convolute cover to access the cable.
 - c. Hold the jump-start cable up to the mounting hole on the support bracket.
 - d. Feed the cable under the frame following the path of the other cable(s) to the starter. Mark the cable where it passes the base of the positive post on the starter.
23. Adjust the length of the new jump-start cable. Replace the starter-end terminal.
- a. Remove the tape securing the convolute cover on the cable, if present.
 - b. Cut the cable squarely at the length determined in step 21.
 - c. Position the 4/0 diameter heat shrink sleeve (66-47062-000) on the cable.
 - d. Remove a minimum of 1.2 inch (32 mm) of the cable insulation without damaging the wire strands.
 - e. Straighten any bent strands of the conductor.
 - f. Fully seat the conductor in the terminal (23-13773-004).
 - g. Position the new terminal according to the orientation drawing. See Fig. [Fig. 133](#).

F1029 A-O

Creation Date: May 2026

NHTSA #26V-079

Transport Canada #2026-054

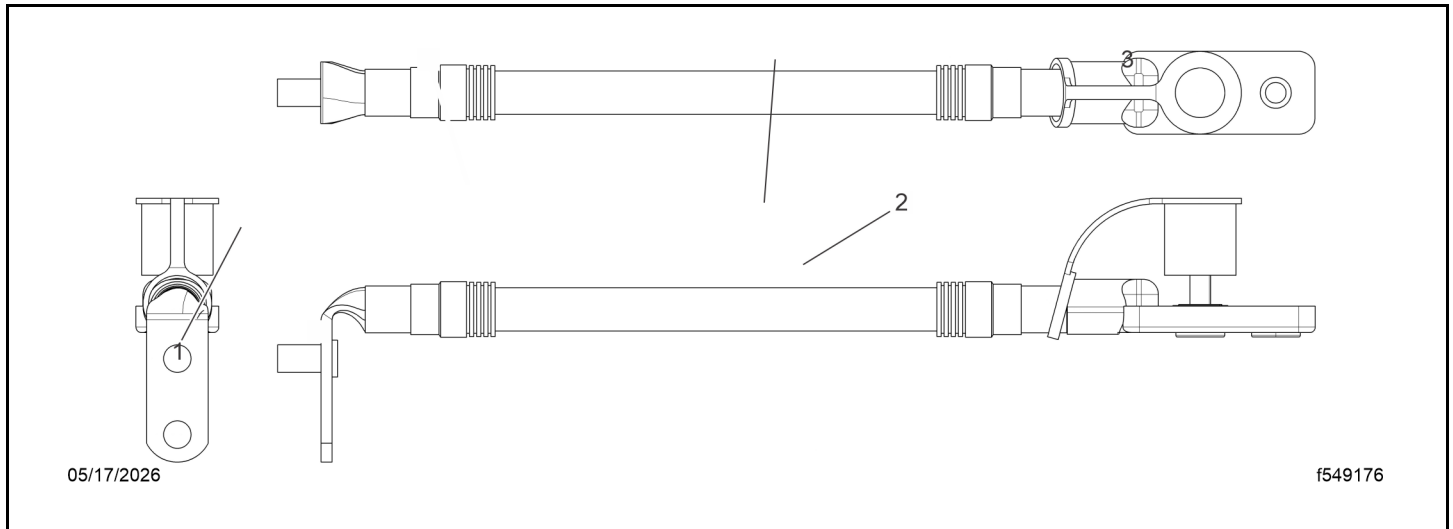

Fig 133, Jump-Start Cable Orientation

- h. Adjust the crimping tool to the correct cable size.
- i. Position the crimping tool approximately 3/8 inch (9 mm) from the open end of the barrel and crimp the terminal.

NOTE: If the new jump-start cable terminal does not fit over the conductor easily, deburr the inside diameter of the barrel opening.

NOTE: If the strands of the conductor are too frayed to fit into the terminal barrel, use a small cable tie to make two wraps around the conductor near the end of the insulation. Tighten the tie and push it towards the end of the conductor to compact the strands. Stop with enough remaining conductor to start the terminal, push it on, and remove the tie.

- 24. Apply heat shrink to the cable.
 - a. Slide the heat shrink into position on the terminal.
 - b. Activate the heat shrink sleeve by heating it evenly at one end until it adapts to the size of the terminal and the adhesive liquefies. Continue heating the sleeve on all sides, working from one end to the other.
 - c. Confirm a continuous ring of adhesive can be seen around the circumference of the sleeve at both ends. See Fig. [Fig. 134](#).

F1029 A-O

Creation Date: May 2026

NHTSA #26V-079

Transport Canada #2026-054

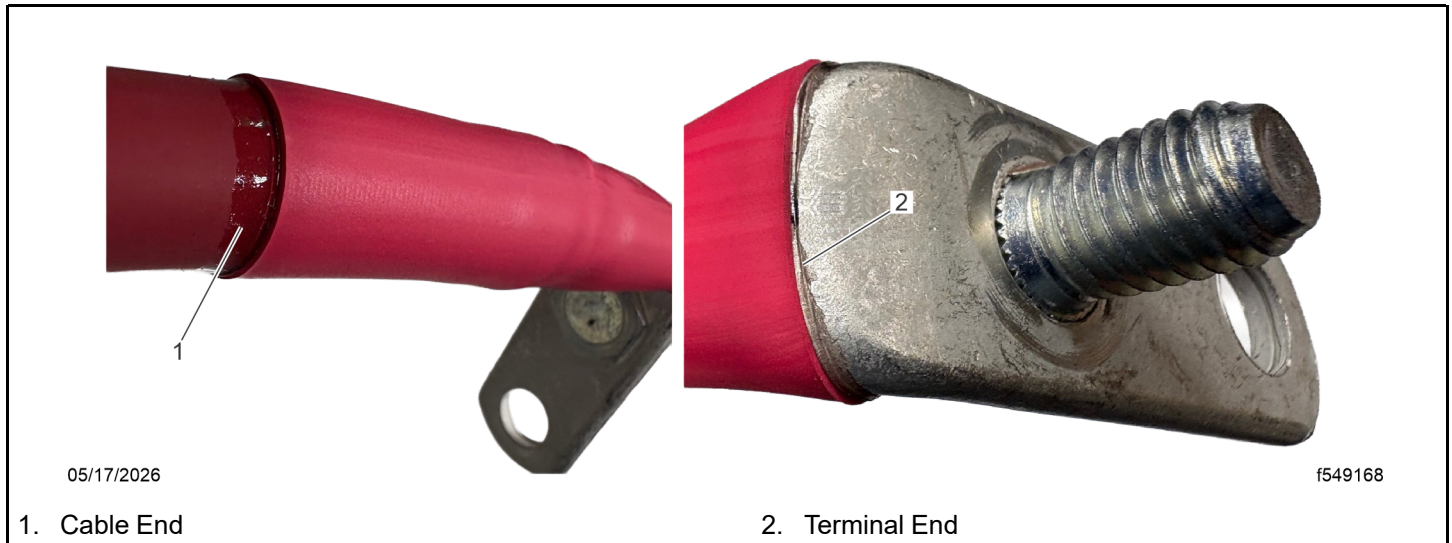

Fig 134, Continuous Adhesive Seal at Cable and Terminal Ends

- d. Install the convolute cover by applying red electrical tape to cover the transition from the heat shrink to the convolute cover. See Fig. [Fig. 135](#).

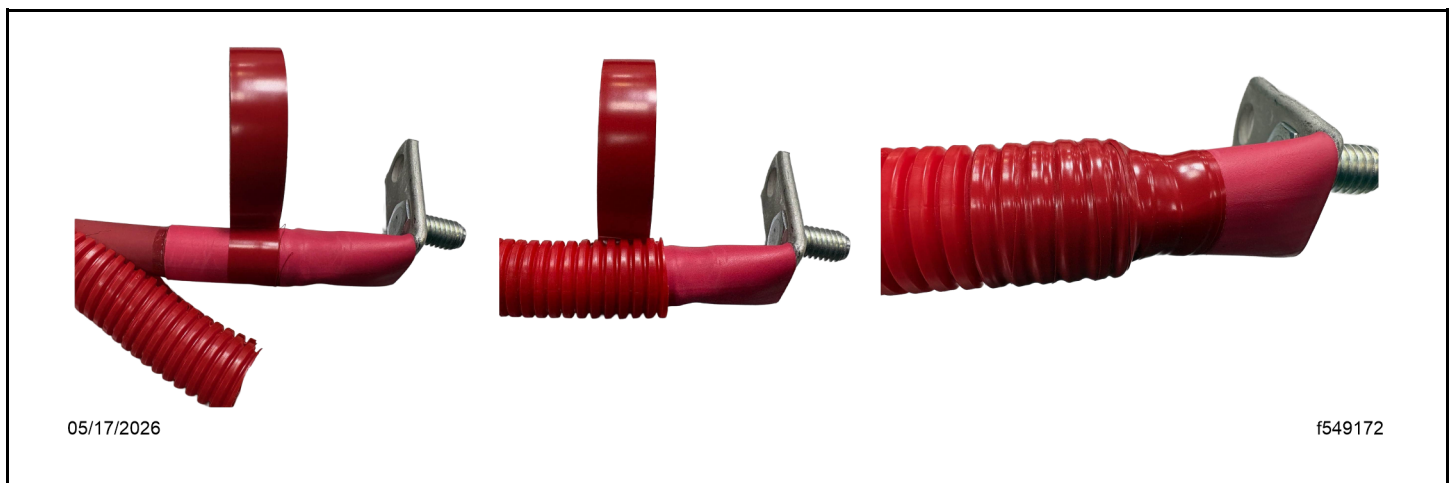

Fig 135, Installing the Convolute Cover

25. Install the convolute cover (48-25360-019) on the new auxiliary Battery Cable Access (BCA) cable (A06-35801-060).
 - a. Apply red electrical tape to cover the transition from the heat shrink to the convolute on the starter end of the cable.
 - b. From the starter end of the cable, add two tape rings at approximately 6 to 8 inch (150 to 200 mm) increments to secure the convolute to the cable. Leave the remaining cover loose until the butt connection has been made and sealed.

F1029 A-O

Creation Date: May 2026

NHTSA #26V-079

Transport Canada #2026-054

26. Assemble the new auxiliary BCA to the jump-start cable. See Fig. [Fig. 136](#).



Fig 136, Assembled Jump-Start and BCA Cables

- a. Position the auxiliary BCA cable end on the extra post of the jump-start cable to fit with the other cables on the starter. Ensure the two cables do not cross between the starter and the under-frame routing bracket.
 - b. Install the nut (23-09596-050) and washer (23-10900-050). Tighten the fasteners 19 lbf·ft (26 N·m).
27. Install the jump-start auxiliary BCA cable assembly on the starter. Tighten 19 lbf·ft (26 N·m).
28. Apply dielectric red enamel paint to the exposed surfaces of the cable ends at the starter.
29. Install the 5/8" tie block (23-13805-062) on the bottom isolator bracket frame bolt so the cable routing can be set passing by it.

F1029 A-O

Creation Date: May 2026

NHTSA #26V-079

Transport Canada #2026-054

30. Route the jump-start auxiliary BCA cables next to the other heavy positive cable(s) from the starter to the lower frame rail support bracket. See Fig. **Fig. 137**.

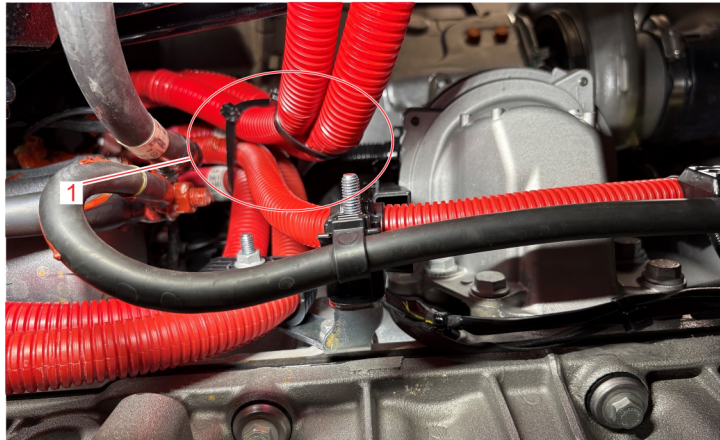

05/17/2026

f549179

Fig 137, Securing the Cables

31. Route the auxiliary BCA and jump-start cables on the lower frame rail support bracket using the new routing clamps (23-14775-002) sized for 2/0 and 4/0 cables.

NOTE: If the cables routing under the frame include a ground cable utilizing the one of the two routing clamp holes, route the 4/0 cables in the original clamps and butterfly the BCA cable along the path using butterfly ties (TYCDCT110HIR).

F1029 A-O

Creation Date: May 2026

NHTSA #26V-079

Transport Canada #2026-054

32. Route the jump-start cable to the support bracket and the bolt (N910105 008016), cable, washer (23-10900-038), and nut (23-12612-008). Hand-tighten the fasteners. See Fig. [Fig. 138](#).



Fig 138, Jump-Start Cable Support Bracket

33. Remove the 5/8" tie block. Tighten the frame bolts that secure the isolator and clipping brackets to the frame rail to 148 lbf·ft (200 N·m).
34. If required, apply touch-up paint to the frame bolts.
35. Install the 5/8" tie block (23-13805-062) on the bottom isolator bracket frame bolt.

F1029 A-O

Creation Date: May 2026

NHTSA #26V-079

Transport Canada #2026-054

36. Determine the ideal length for the new auxiliary BCA cable between the starter and butt connector. Cut the cable. See Fig. Fig. 139.

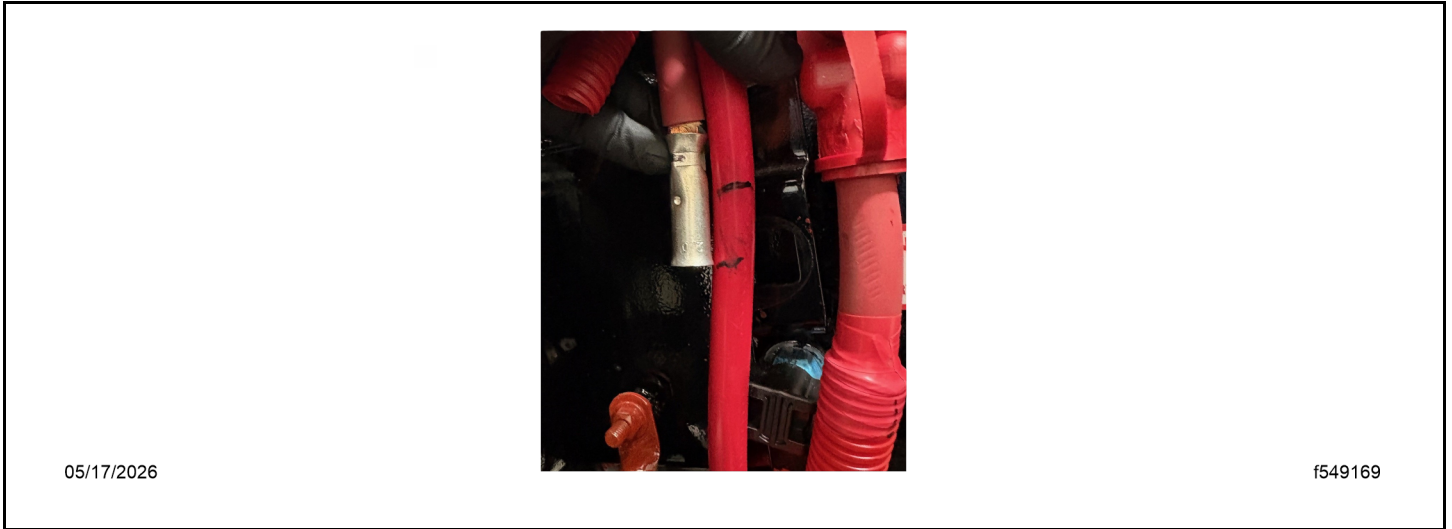

Fig 139, Determining the BCA Cable Length

37. Position three pieces of heat shrink tubing (66-47062-001) on the auxiliary BCA cable with one on the upper cable and two on the lower cable.
- NOTE:** Position the heat shrink tube to allow enough room to complete the butt crimp process without damaging it. If the heat shrink is damaged and splits during the heating process, the terminal must be replaced to ensure the connection is watertight.
38. Crimp the butt connector.
- Remove the cable insulation equal to half the butt connector length without damaging the wire strands.
 - Straighten any bent conductor strands.
 - Fully seat the conductor in the terminal.
 - Adjust the crimping tool to the correct cable size.
 - Crimp the terminal.

F1029 A-O

Creation Date: May 2026

NHTSA #26V-079

Transport Canada #2026-054

39. Insulate the butt connection with heat shrink sleeves. See Fig. Fig. 140.

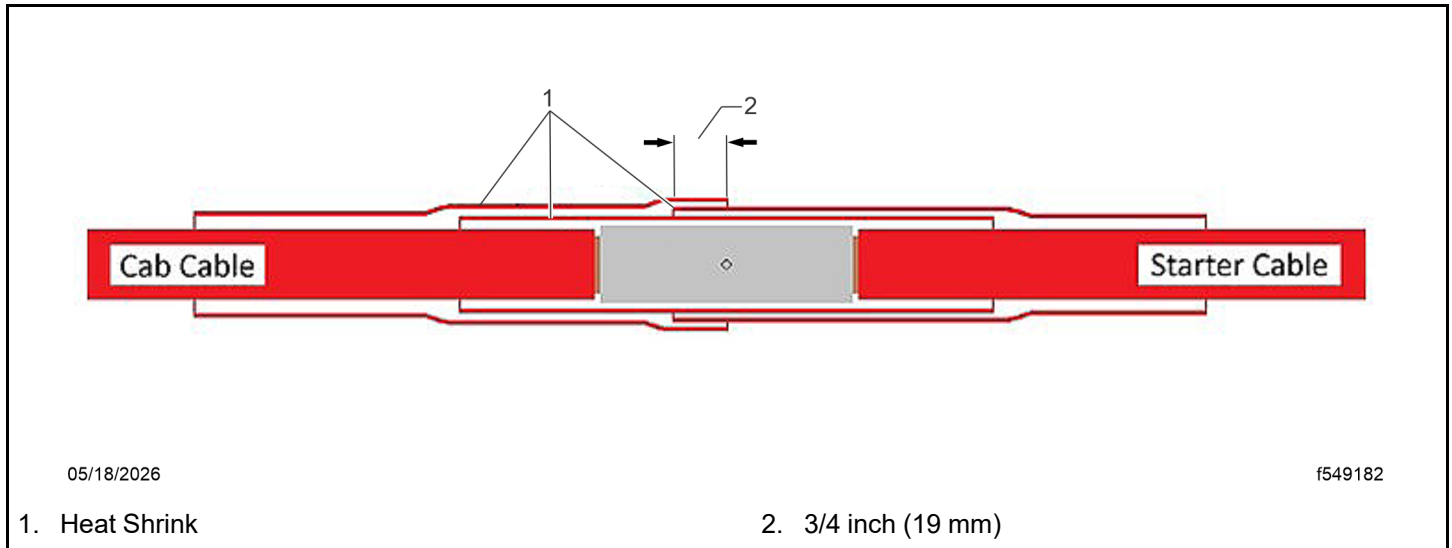

Fig 140, Heat Shrink Insulation

- a. Center the first piece of heat shrink sleeve on the terminal.
 - b. Activate the sleeve by heating it evenly from one end until it adapts to the size of the cable and the adhesive liquefies.
 - c. Continue heating the sleeve on all sides, working from one end to the other.
 - d. Confirm a continuous ring of adhesive can be seen around the circumference of the sleeve at both ends.
 - e. Position the second sleeve on the lower cable and overlap the center of the first sleeve by 3/4 inch (19 mm).
 - f. Activate the second sleeve by heating it evenly from one end until it adapts to the size of the cable and the adhesive liquefies.
 - g. Continue heating the second sleeve on all sides, working from one end to the other.
 - h. Confirm a continuous ring of adhesive can be seen around the circumference of the second sleeve at both ends.
 - i. Position the third sleeve on the upper cable and overlap the top of the second sleeve by 3/4 inch (19 mm).
 - j. Activate the third sleeve and inspect for a continuous ring of sealant at both ends.
40. Cover the heat shrink joint with convolute tubing. If extra convolute tubing is required, use 4/0 Red Slit Convolute (48-25360-022) for 4/0 cables, and CONDUIT-NYL, 19MM, FLEX (48-25360-019) for 2/0 cables.
41. Apply red electrical tape to the cable and then to the convolute end to create a seamless transition between the ends of the convolute.

F1029 A-O

Creation Date: May 2026

NHTSA #26V-079

Transport Canada #2026-054

42. Install the upper and lower cable clamps on the isolator frame bracket. To prevent cables (A) from rubbing, secure any cables routed on the outside cable clamps (B) using butterfly cable ties (C) (TYCDCT110HIR). See Fig. **Fig. 141**.

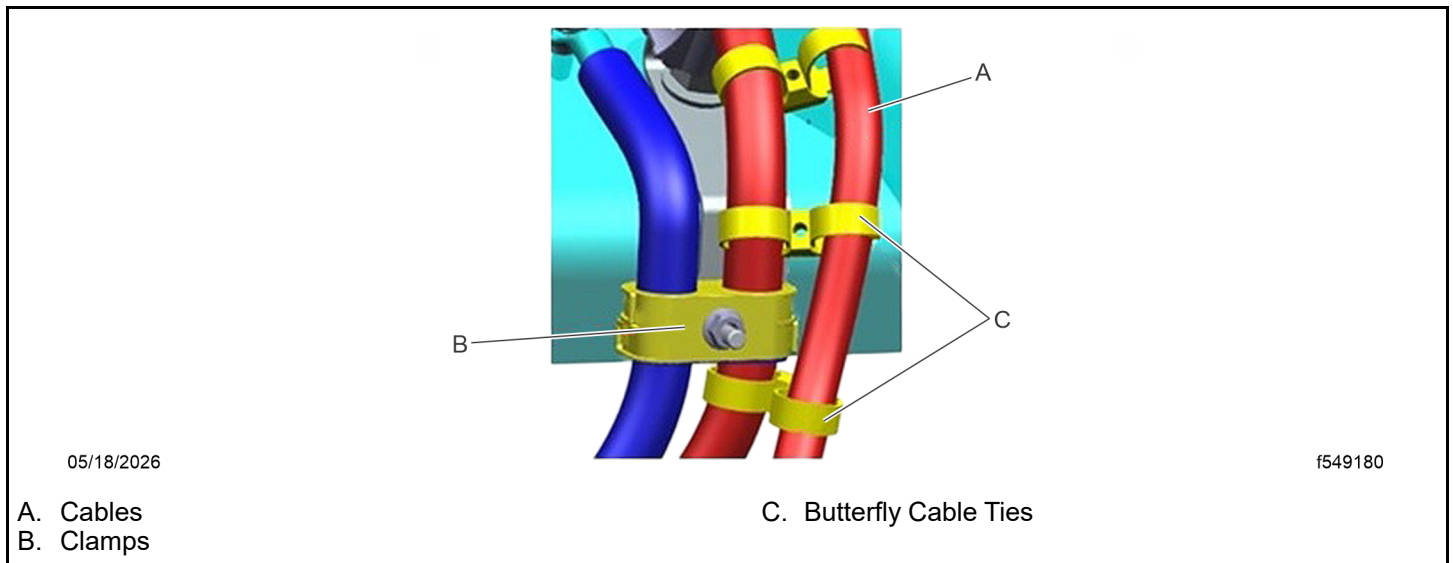

Fig 141, Butterfly Cable Ties Around the Cable Clamps

43. Secure the cables to the 5/8" tie block with a Heavy Duty (HD) cable tie (23-13476-000) and other points where positive power cables are routed together.
44. Use butterfly cable ties (TYCDCT110HIR) to route positive cables next to any other cables or anywhere along the path where cables must be separated.
- IMPORTANT: Ensure no power cables are rubbing, or close to rubbing, the frame or engine components.
45. Remove the nut holding the jump-start cable to the support bracket. Apply medium strength thread locker. Install the assembly. Tighten 14 lbf·ft (19 N·m).

F1029 A-O

Creation Date: May 2026

NHTSA #26V-079

Transport Canada #2026-054

46. Install the nylon nut (23-13379-001) on the tail of the bolt holding the jump-start cable to the support bracket (1). Tighten 7lbf·ft (9.5 N·m). See Fig. [Fig. 142](#).



Fig 142, Nylon Nut on Jump-Start Bracket Fastener

1. Nylon Nut
47. If removed, install the splash shield behind the front tire. For detailed instructions, see Group 88 of the *47X, 48X and 49X Workshop Manual*.
48. Install the negative cable connections at the batteries.
49. Clean a spot on the base label (Form WAR259) and attach a campaign completion sticker for F1029 (Form WAR260).

F1029 A-O

Creation Date: May 2026

NHTSA #26V-079

Transport Canada #2026-054

Group L Work Instructions

1. Check the base label (Form WAR259) for a completion sticker for F1029 (Form WAR260), indicating this work has been done. The base label is usually located on the passenger-side door, about 12 inches (30 cm) below the door latch. If a completion sticker is present, no work is needed. If a completion sticker is not present, proceed to the next step.
2. Park the vehicle on a level surface and set the parking brake. Chock the rear tires.
3. Turn the steer wheels to the left side to make the isolated stud accessible. Shut down the engine.
4. Open the hood.
5. Locate the isolated positive (+) battery stud mounted on the frame behind the front wheel. See Fig. [Fig. 143](#).

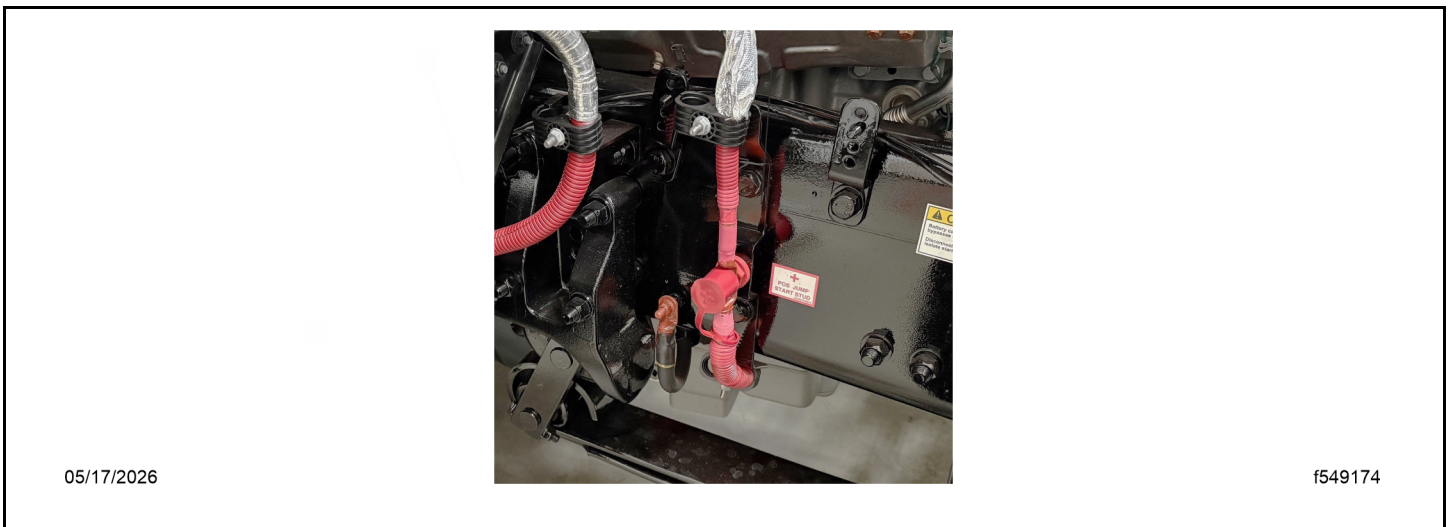

Fig 143, Isolated Battery Junction with Jump-Start Post

6. Remove the negative (-) cable connection(s) from the batteries.
7. If required for access, remove the splash shield from behind the front tire. For detailed instructions, see Group 88 of the *47X, 48X and 49X Workshop Manual*.
8. Remove the jump-start post or nut that secures the battery cable(s) to the isolated stud.
9. Remove the clamp(s) that secure the positive battery cables to the clipping point above the frame rail.
10. Remove the clamp(s) and ties that secure the positive battery cable routed between the isolated stud and the starter.
11. Remove the nut that secures the positive battery cables to the starter.
12. Remove the cable that connects the isolated stud to the starter.
13. Assemble the routing support bracket (12-25410-000) with the bolt (N910105 008016) and nut (23-12612-008). Apply medium strength thread locker in the second small hole from the end.
14. Remove the top bolt that secures the cable routing bracket to the frame. Fit the assembled support bracket and washer. Install the bolt with the nut on the inside of the frame.

F1029 A-O

Creation Date: May 2026

NHTSA #26V-079

Transport Canada #2026-054

15. Hold the bracket in the approximate position shown. Tighten the frame bolt 148 lbf·ft (200 N·m).
16. Remove the isolated stud bracket and discard it.
17. Install the bottom stud bracket bolt to fill the hole in the frame.
18. Fit the jump-start cable bracket (12-25410-000) and washer to the top stud bracket frame bolt. Install the nut so the bracket remains loose.
19. Position the jump-start support bracket bolt (N910105 008016) in the bracket.

NOTE: The bolt that secures the jump-start cable to the support bracket may be too long to be installed when the frame bolt is tight. It should be positioned in the bracket hole before tightening the frame bolt.

20. Align the jump-start support bracket vertically on the frame. Tighten all the frame bolts 148 lbf·ft (200 N·m).
21. If required, apply touch-up paint to the frame bolts.
22. Remove the ring terminal from the positive cable that is routed to the cab.
 - a. Note how the cable is secured and remove any cable ties, tape, or convolute as needed to uncover at least 6 inches of the cable.
 - b. Remove the original heat shrink. To do so, heat it, score it, and continue to heat it until the score splits and the adhesive softens. See Fig. [Fig. 144](#).

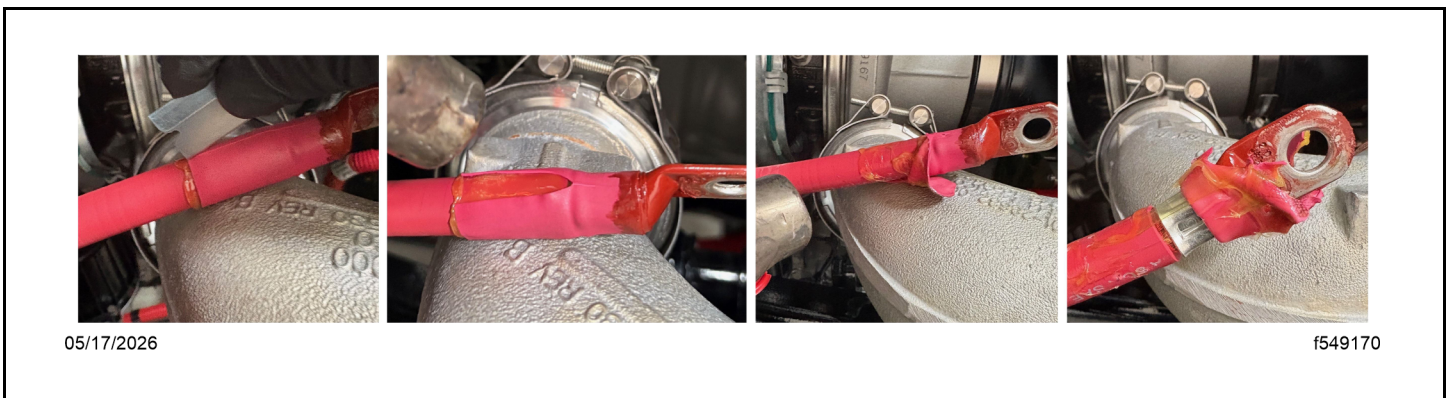

Fig 144, Heat Shrink Removal

- c. Cut the cable just above the ring terminal.
- d. Remove the cable insulation equal to half the butt connector length without damaging the wire strands. See Fig. [Fig. 145](#).

F1029 A-O

Creation Date: May 2026

NHTSA #26V-079

Transport Canada #2026-054



Fig 145, Removing the Insulation

- e. Straighten any bent strands of the conductor.

NOTE: To ensure proper crimp force is applied to the terminal, the cable cuts must be square and the number of damaged or lost strands must be minimized.

- 23. Inspect the conductor for evidence of corrosion. Is corrosion present on the newly exposed conductor?

NOTE: The cable must be replaced if cutting back the corrosion causes the cable to become too short for the butt terminal to be supported by the routing clamp above the frame rail.

- a. **YES** → Cut off about 1 inch (25 mm) of cable. Repeat steps 22d through 22e to remove the cable insulation. Evaluate the condition of the conductor.
- b. **NO** → Go to step 24.

F1029 A-O

Creation Date: May 2026

NHTSA #26V-079

Transport Canada #2026-054

24. Crimp the butt connector terminal (PHM 8 2960) on the cable routed to the cab. See Fig. [Fig. 146](#).

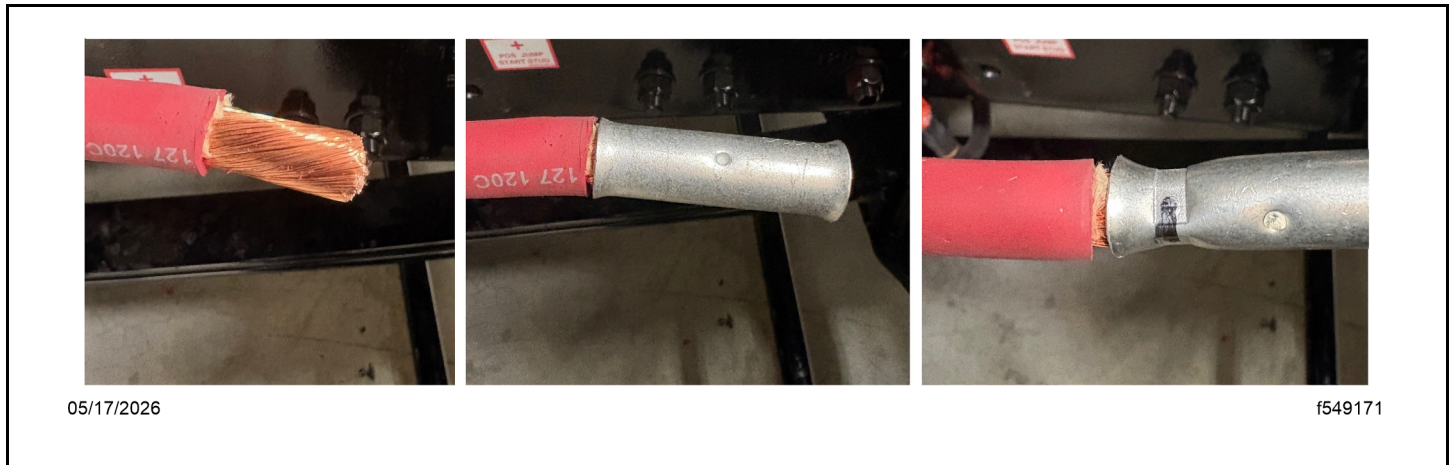

Fig 146, Installing and Crimping the Terminal

- a. Fully seat the conductor in the terminal.
 - b. Adjust the crimping tool to the correct cable size.
 - c. Position the crimping tool approximately 5/16 inch (8 mm) from the open end of the barrel. Crimp the terminal.
- NOTE:** To prevent the cable strands from entering the heat shrink over time, all the cable strands must be inserted into the terminal. If the cable strands are outside the barrel, wind them around the conductor in the gap between the cable insulation and the terminal. Apply electrical tape over the gap to prevent them from contacting the heat shrink layer.
25. Install the post-mount cable tie (23-13322-008) on the rear post (A) of the routing bracket. Route the jump-start cable on the aft side of the post.
 26. Determine the length of the new jump-start cable (A66-12311-046).
 - a. Compare the old starter cable to the new jump-start cable.
 - b. Remove the tape securing the convolute cover to access the cable.
 - c. Hold the jump-start cable up to the mounting hole on the support bracket.
 - d. Feed the cable under the frame following the path of the other cable(s) to the starter. Mark the cable where it passes the base of the positive post on the starter.
 27. Adjust the length of the new jump-start cable. Replace the starter-end terminal.
 - a. Remove the tape securing the convolute cover on the cable, if present.
 - b. Cut the cable squarely at the length determined in step 21.
 - c. Position the 4/0 diameter heat shrink sleeve (66-47062-000) on the cable.
 - d. Remove a minimum of 1.2 inch (32 mm) of the cable insulation without damaging the wire strands.
 - e. Straighten any bent strands of the conductor.

F1029 A-O

Creation Date: May 2026

NHTSA #26V-079

Transport Canada #2026-054

- f. Fully seat the conductor in the terminal (23-13773-004).
- g. Position the new terminal according to the orientation drawing. See Fig. [Fig. 147](#).

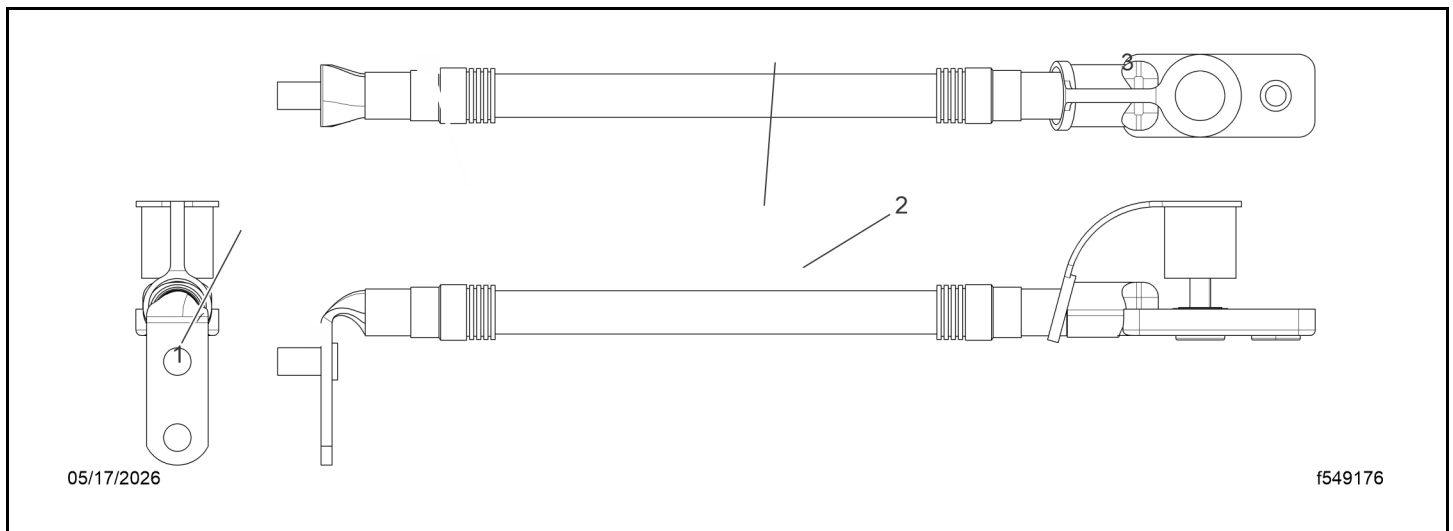

Fig 147, Jump-Start Cable Orientation

- h. Adjust the crimping tool to the correct cable size.
- i. Position the crimping tool approximately 3/8 inch (9 mm) from the open end of the barrel and crimp the terminal.

NOTE: If the new jump-start cable terminal does not fit over the conductor easily, deburr the inside diameter of the barrel opening.

NOTE: If the strands of the conductor are too frayed to fit into the terminal barrel, use a small cable tie to make two wraps around the conductor near the end of the insulation. Tighten the tie and push it towards the end of the conductor to compact the strands. Stop with enough remaining conductor to start the terminal, push it on, and remove the tie.

- 28. Apply heat shrink to the cable.
 - a. Slide the heat shrink into position on the terminal.
 - b. Activate the heat shrink sleeve by heating it evenly at one end until it adapts to the size of the terminal and the adhesive liquefies. Continue heating the sleeve on all sides, working from one end to the other.
 - c. Confirm a continuous ring of adhesive can be seen around the circumference of the sleeve at both ends. See Fig. [Fig. 148](#).

F1029 A-O

Creation Date: May 2026

NHTSA #26V-079

Transport Canada #2026-054

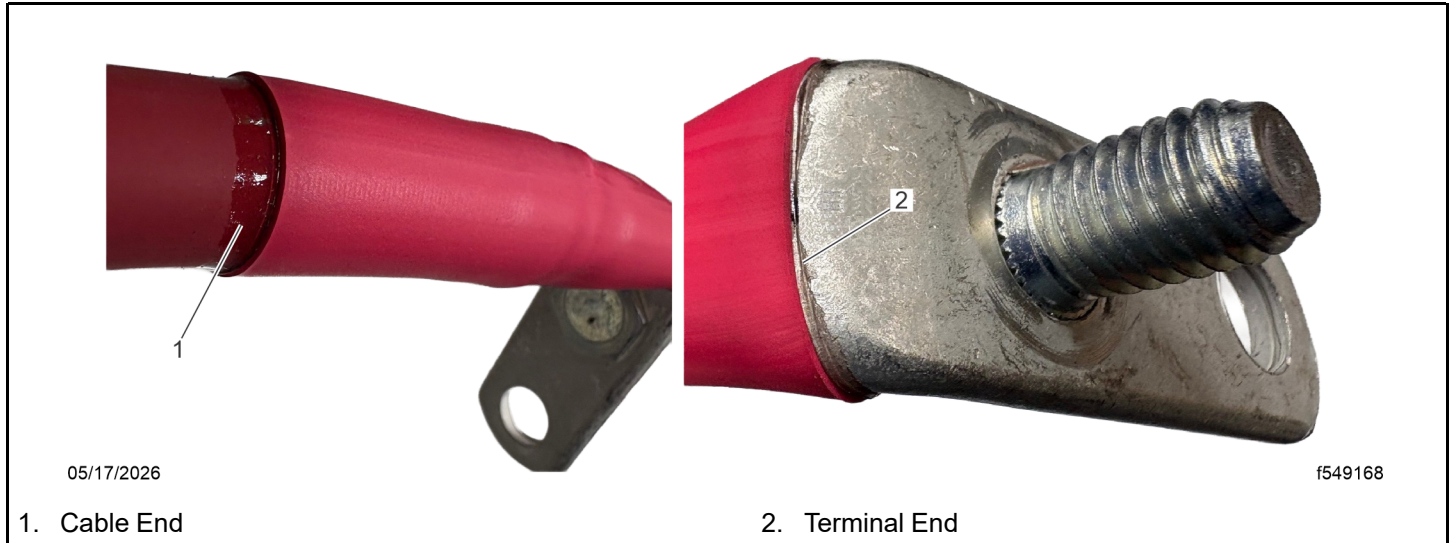

Fig 148, Continuous Adhesive Seal at Cable and Terminal Ends

- d. Install the convolute cover by applying red electrical tape to cover the transition from the heat shrink to the convolute cover. See Fig. [Fig. 149](#).

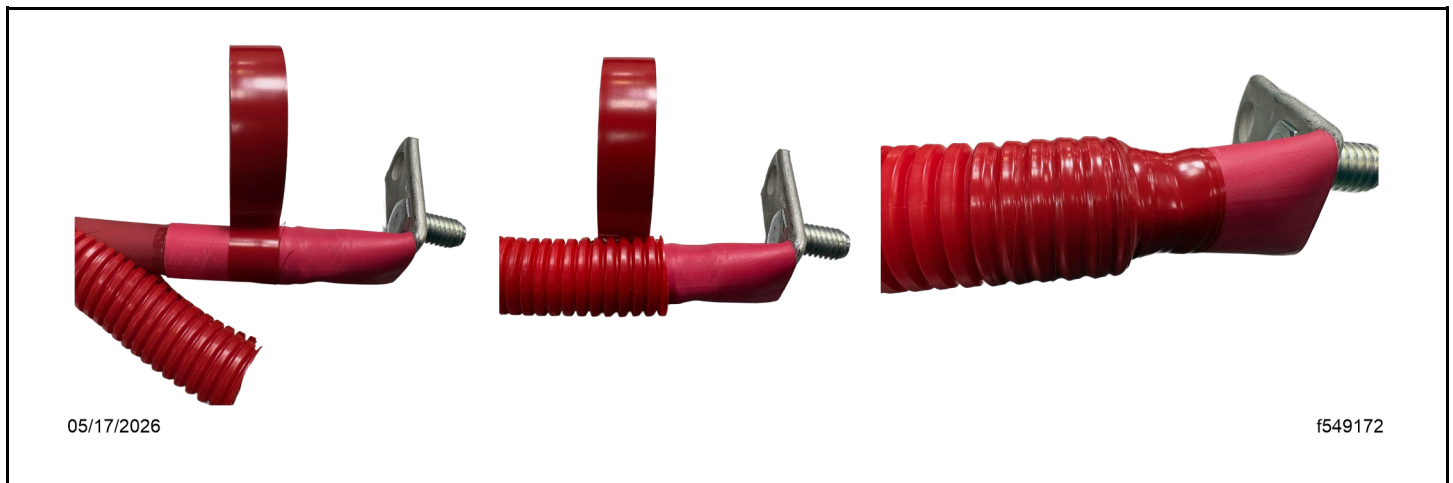

Fig 149, Installing the Convolute Cover

29. Install the convolute cover (48-25360-019) on the new auxiliary Battery Cable Access (BCA) cable (A06-35801-060).
 - a. Apply red electrical tape to cover the transition from the heat shrink to the convolute on the starter end of the cable.
 - b. From the starter end of the cable, add two tape rings at approximately 6 to 8 inch (150 to 200 mm) increments to secure the convolute to the cable. Leave the remaining cover loose until the butt connection has been made and sealed.

F1029 A-O

Creation Date: May 2026

NHTSA #26V-079

Transport Canada #2026-054

30. Assemble the new auxiliary BCA to the jump-start cable. See Fig. [Fig. 150](#).



Fig 150, Assembled Jump-Start and BCA Cables

- a. Position the auxiliary BCA cable end on the extra post of the jump-start cable to fit with the other cables on the starter. Ensure the two cables do not cross between the starter and the under-frame routing bracket.
 - b. Install the nut (23-09596-050) and washer (23-10900-050). Tighten the fasteners 19 lbf·ft (26 N·m).
31. Install the jump-start auxiliary BCA cable assembly on the starter. Tighten 19 lbf·ft (26 N·m).
32. Apply dielectric red enamel paint to the exposed surfaces of the cable ends at the starter.

F1029 A-O

Creation Date: May 2026

NHTSA #26V-079

Transport Canada #2026-054

33. Route the jump-start auxiliary BCA cables next to the other heavy positive cable(s) from the starter to the lower frame rail support bracket. See Fig. **Fig. 151**.

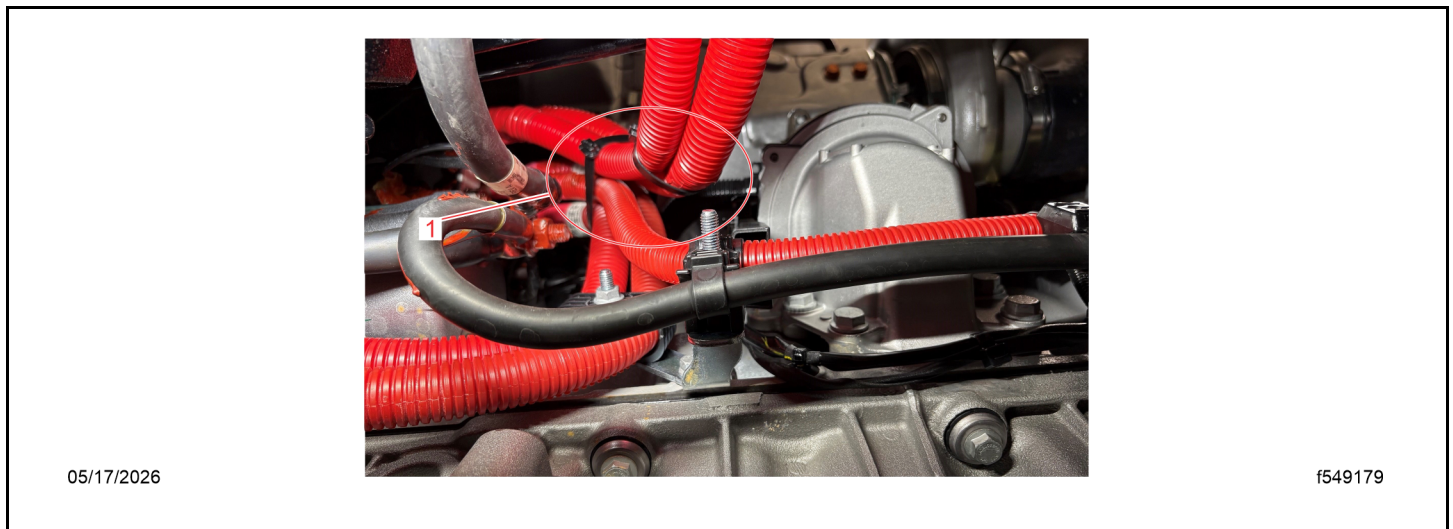

Fig 151, Securing the Cables

1. Secured Cables

34. Use the forward post of the lower routing clamp (23-14775-002) to support the 4/0 positive cable in the forward position and the 2/0 auxiliary BCA cable in the rear position as it routes under the frame.

NOTE: If the cables routing under the frame include a ground cable utilizing the one of the two routing clamp holes, route the 4/0 cables in the original clamps and butterfly the BCA cable along the path using butterfly ties (TYCDCT110HIR).

35. Route the jump-start cable to the support bracket and fit the cable, washer (23-10900-038). Apply medium strength thread locker. Tighten the nut (23-12612-008) 14 lbf·ft (19 N·m).

F1029 A-O

Creation Date: May 2026

NHTSA #26V-079

Transport Canada #2026-054

36. Install the nylon nut (23-13379-001) on the tail of the bolt that secures the jump-start cable to the support bracket (1). Tighten the nut 7 lbf·ft (9.5 Nm). See Fig. [Fig. 152](#).



Fig 152, Nylon Nut on Jump-Start Bracket Fastener

1. Nylon Nut

37. Determine the ideal length for the new auxiliary BCA cable between the starter and butt connector. Cut the cable. See Fig. [Fig. 153](#).

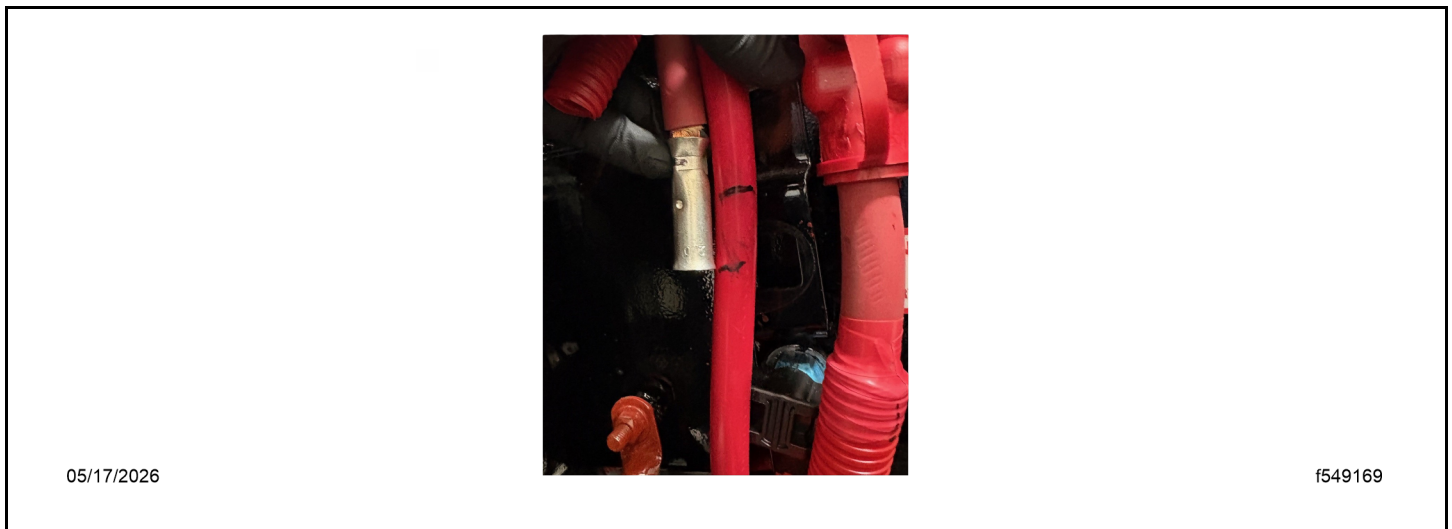

Fig 153, Determining the BCA Cable Length

F1029 A-O

Creation Date: May 2026

NHTSA #26V-079

Transport Canada #2026-054

38. Position three pieces of heat shrink tubing (66-47062-001) on the auxiliary BCA cable with one on the upper cable and two on the lower cable.

NOTE: Position the heat shrink tube to allow enough room to complete the butt crimp process without damaging it. If the heat shrink is damaged and splits during the heating process, the terminal must be replaced to ensure the connection is watertight.

39. Crimp the butt connector.
- Remove the cable insulation equal to half the butt connector length without damaging the wire strands.
 - Straighten any bent conductor strands.
 - Fully seat the conductor in the terminal.
 - Adjust the crimping tool to the correct cable size.
 - Crimp the terminal.
40. Insulate the butt connection with heat shrink sleeves. See Fig. [Fig. 154](#).

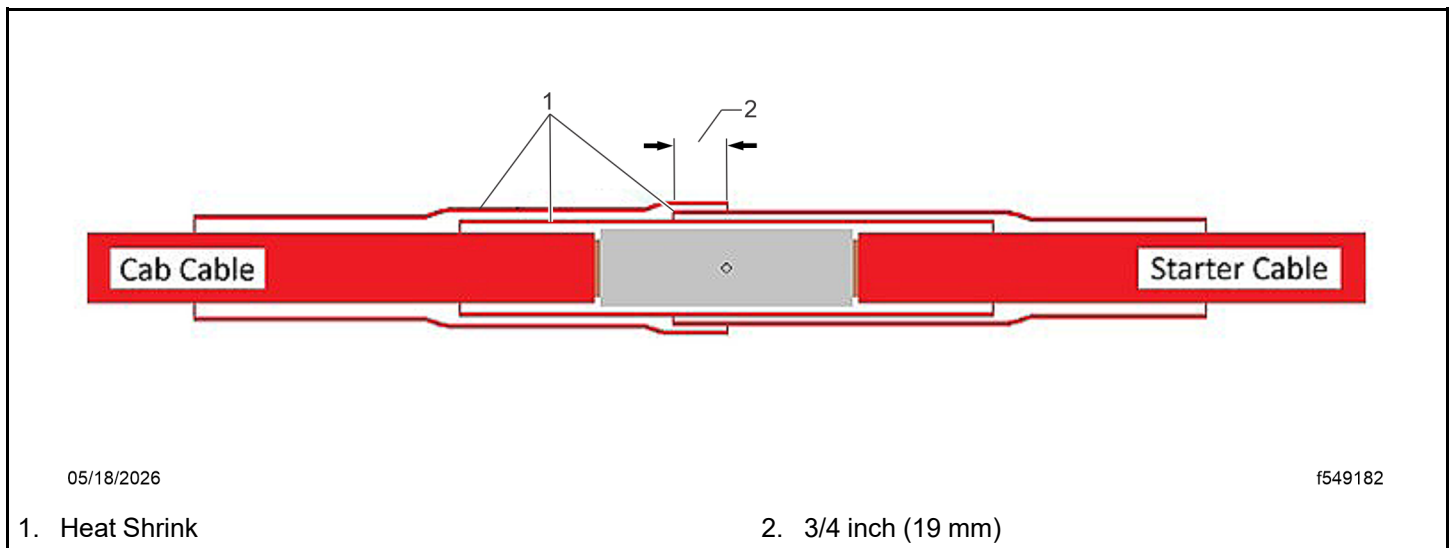

Fig 154, Heat Shrink Insulation

- Center the first piece of heat shrink sleeve on the terminal.
- Activate the sleeve by heating it evenly from one end until it adapts to the size of the cable and the adhesive liquefies.
- Continue heating the sleeve on all sides, working from one end to the other.
- Confirm a continuous ring of adhesive can be seen around the circumference of the sleeve at both ends.
- Position the second sleeve on the lower cable and overlap the center of the first sleeve by 3/4 inch (19 mm).
- Activate the second sleeve by heating it evenly from one end until it adapts to the size of the cable and the adhesive liquefies.

F1029 A-O

Creation Date: May 2026

NHTSA #26V-079

Transport Canada #2026-054

- g. Continue heating the second sleeve on all sides, working from one end to the other.
 - h. Confirm a continuous ring of adhesive can be seen around the circumference of the second sleeve at both ends.
 - i. Position the third sleeve on the upper cable and overlap the top of the second sleeve by 3/4 inch (19 mm).
 - j. Activate the third sleeve and inspect for a continuous ring of sealant at both ends.
41. Cover the heat shrink joint with convolute tubing. If extra convolute tubing is required, use 4/0 Red Slit Convolute (48-25360-022) for 4/0 cables, and CONDUIT-NYL,19MM,FLEX (48-25360-019) for 2/0 cables.
 42. Apply red electrical tape to the cable and to the convolute end to create a seamless transition between the ends of the convolute.
 43. Install the upper and lower cable clamps on the isolator frame bracket. To prevent cables (A) from rubbing, secure any cables routed on the outside cable clamps (B) using butterfly cable ties (C) (TYCDCT110HIR). See Fig. **Fig. 155**.

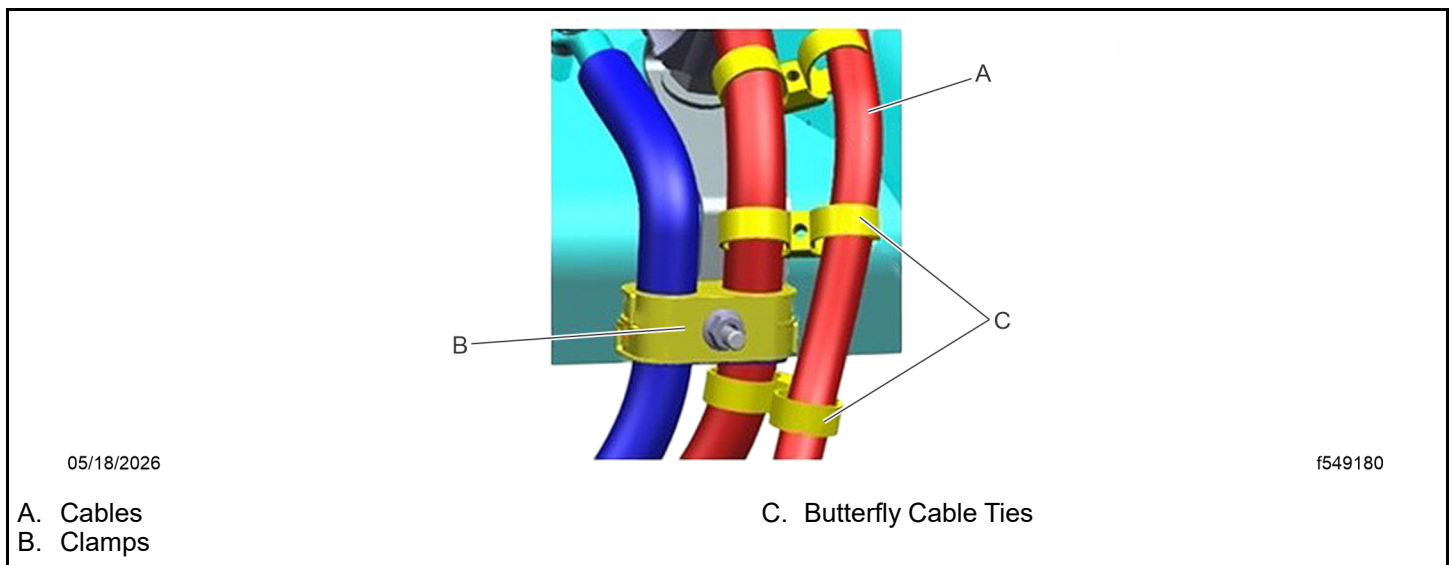

Fig 155, Butterfly Cable Ties Around the Cable Clamps

44. Secure the cables to the 5/8 inch (16 mm) tie block with a Heavy Duty (HD) cable tie (23-13476-000) and other points where positive power cables are routed together.
45. Use butterfly cable ties (TYCDCT110HIR) to route positive cables next to any other cables or anywhere along the path where cables must be separated.
IMPORTANT: Ensure no power cables are rubbing, or close to rubbing, the frame or engine components.
46. If removed, install the splash shield behind the front tire. For detailed instructions, see Group 88 of the *47X, 48X and 49X Workshop Manual*.
47. Install the negative cable connections at the batteries.
48. Clean a spot on the base label (Form WAR259) and attach a campaign completion sticker for F1029 (Form WAR260).

F1029 A-O

Creation Date: May 2026

NHTSA #26V-079

Transport Canada #2026-054

Group M Work Instructions

1. Check the base label (Form WAR259) for a completion sticker for F1029 (Form WAR260), indicating this work has been done. The base label is usually located on the passenger-side door, about 12 inches (30 cm) below the door latch. If a completion sticker is present, no work is needed. If a completion sticker is not present, proceed to the next step.
2. Park the vehicle on a level surface and set the parking brake. Chock the rear tires.
3. Turn the steer wheels to the left side to make the isolated stud accessible. Shut down the engine.
4. Open the hood.
5. Locate the isolated positive (+) battery stud mounted on the frame behind the front wheel. See Fig. [Fig. 156](#).

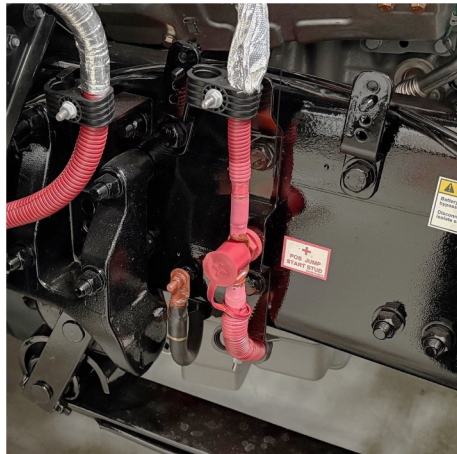

05/17/2026

f549174

Fig 156, Isolated Battery Junction with Jump-Start Post

6. Remove the negative (-) cable connection(s) from the batteries.
7. If required for access, remove the splash shield from behind the front tire. For detailed instructions, see Group 88 of the *47X, 48X and 49X Workshop Manual*.
8. Remove the jump-start post or nut that secures the battery cable(s) to the isolated stud.
9. Remove the clamp(s) that secure the positive battery cables to the clipping point above the frame rail.
10. Remove the clamp(s) and ties that secure the positive battery cables routed between the isolated stud and the starter.
11. Remove the nut that secures the positive battery cables to the starter.
12. Remove the cable that connects the isolated stud to the starter.
13. Remove the bolts that secure the isolated stud bracket to the frame.
14. Remove the isolated stud from the frame bracket.
15. Fit the lower isolator bracket frame bolt in position with the head on the inboard side of the frame.

F1029 A-O

Creation Date: May 2026

NHTSA #26V-079

Transport Canada #2026-054

16. Install the upper isolator bracket bolt with the threads on the inboard side of the frame. Tighten the frame bolts 148 lbf·ft (200 N·m).
17. If required, apply touch-up paint to the frame bolts.
18. Remove the ring terminal from the positive cable that is routed to the cab.
 - a. Note how the cable is secured and remove any cable ties, tape, or convolute as needed to uncover at least 6 inches of the cable.
 - b. Remove the original heat shrink. To do so, heat it, score it, and continue to heat it until the score splits and the adhesive softens. See Fig. [Fig. 157](#).

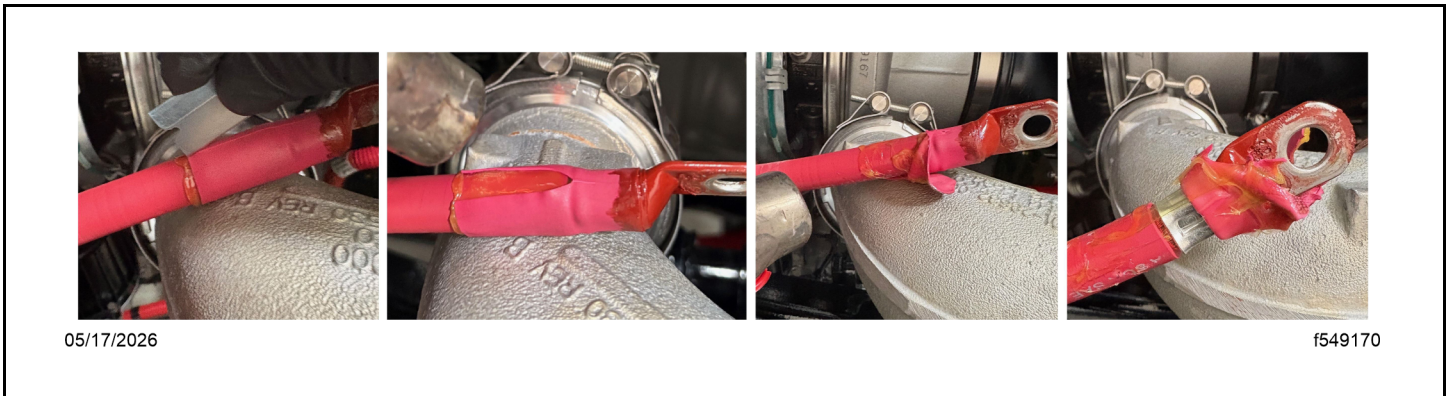

Fig 157, Heat Shrink Removal

- c. Cut the cable just above the ring terminal.
- d. Remove the cable insulation equal to half the butt connector length without damaging the wire strands. Use [Fig. 158](#).

F1029 A-O

Creation Date: May 2026

NHTSA #26V-079

Transport Canada #2026-054



Fig 158, Removing the Insulation

e. Straighten any bent strands of the conductor.

NOTE: To ensure proper crimp force is applied to the terminal, the cable cuts must be square and the number of damaged or lost strands must be minimized.

19. Inspect the conductor for evidence of corrosion. Is corrosion present on the newly exposed conductor?

NOTE: The cable must be replaced if cutting back the corrosion causes the cable to become too short for the butt terminal to be supported by the routing clamp above the frame rail.

a. **YES** → Cut off about 1 inch (25 mm) of the cable. Repeat steps 18d through 18e to remove the cable insulation. Evaluate the condition of the conductor.

b. **NO** → Go to step 20.

F1029 A-O

Creation Date: May 2026

NHTSA #26V-079

Transport Canada #2026-054

20. Crimp the butt connector terminal (PHM 8 2960) of the cable routed to the cab. See Fig. [Fig. 159](#).



Fig 159, Installing and Crimping the Terminal

- a. Fully seat the conductor in the terminal.
 - b. Adjust the crimping tool to the correct cable size.
 - c. Position the crimping tool approximately 5/16 inch (8 mm) from the open end of the barrel. Crimp the terminal.
- NOTE:** To prevent the cable strands from entering the heat shrink over time, all the cable strands must be inserted into the terminal. If the cable strands are outside the barrel, wind them around the conductor in the gap between the cable insulation and the terminal. Apply electrical tape over the gap to prevent them from contacting the heat shrink layer.
21. Install the convolute cover (48-25360-019) on the new auxiliary Battery Cable Access (BCA) cable (A06-35801-060).
 - a. Apply red electrical tape to cover the transition from the heat shrink to the convolute on the starter end of the cable.
 - b. From the starter end of the cable, add two tape rings at approximately 6 to 8 inch (150 to 200 mm) increments to secure the convolute to the cable. Leave the remaining cover loose until the butt connection has been made and sealed.
 22. Install the auxiliary BCA cable assembly on the starter. Tighten 19 lbf-ft (26 N·m).
 23. Apply dielectric red enamel paint to the exposed surfaces of the cable ends at the starter.

F1029 A-O

Creation Date: May 2026

NHTSA #26V-079

Transport Canada #2026-054

24. Install the 5/8 inch (16 mm) tie block (23-13805-062) on the bottom isolator bracket frame bolt so the cable routing can be set passing by it. See Fig. [Fig. 160](#).

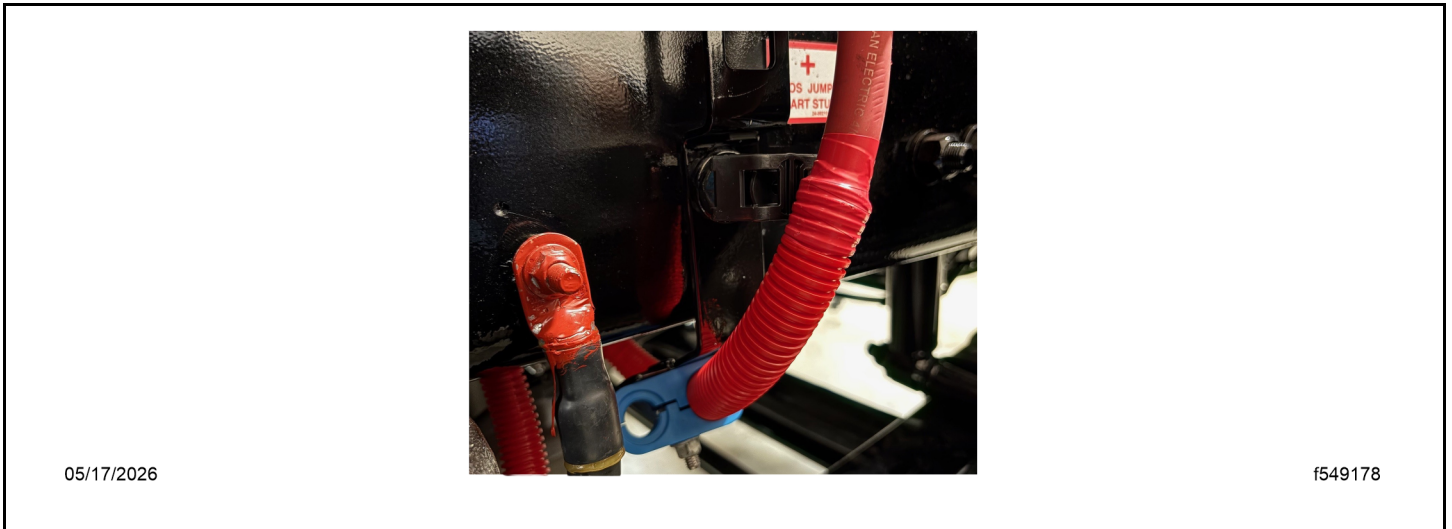

Fig 160, Routing Over the Tie Block

25. Route the auxiliary BCA cable next to the other heavy positive cable(s) from the starter to the lower frame rail support bracket. See Fig. [Fig. 161](#).

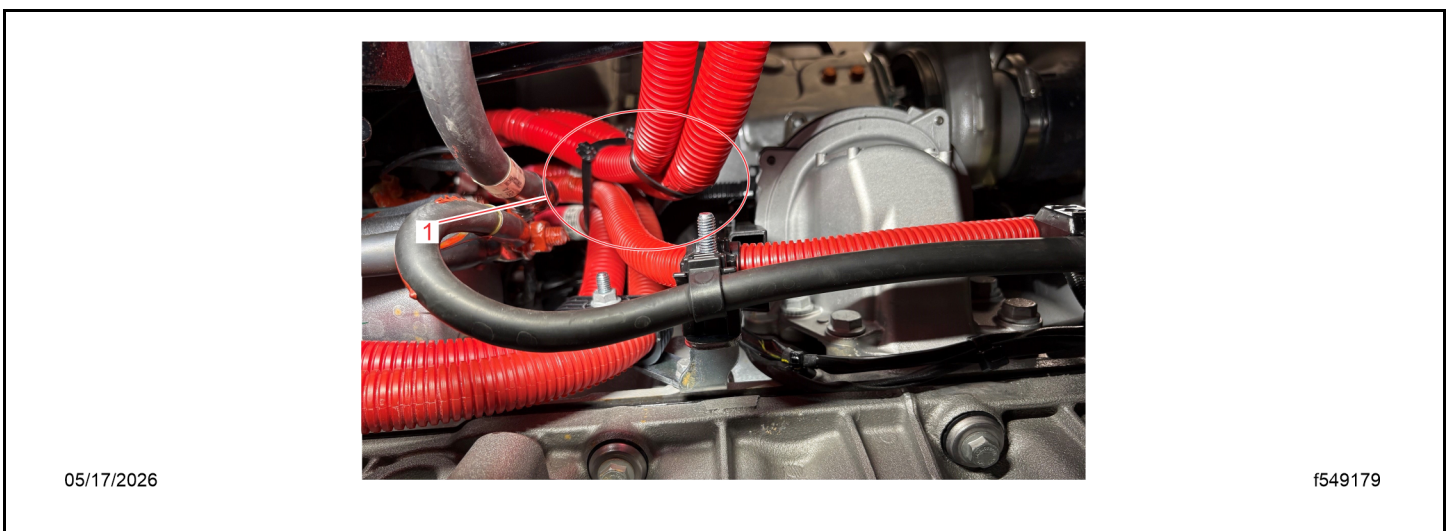

Fig 161, Securing the Cables

F1029 A-O

Creation Date: May 2026

NHTSA #26V-079

Transport Canada #2026-054

1. Secured Cables
26. Route the auxiliary BCA cable from the starter to the lower frame rail support bracket using the new routing clamps (23-14775-002) sized for 2/0 and 4/0 cables.
NOTE: If the cables routing under the frame include a ground cable utilizing the one of the two routing clamp holes, route the 4/0 cables in the original clamps and butterfly the BCA cable along the path using butterfly ties (TYCDCT110HIR).
27. Determine the ideal length for the new auxiliary BCA cable between the starter and butt connector. Cut the cable. See Fig. [Fig. 162](#).



05/17/2026

f549169

Fig 162, Determining the BCA Cable Length

28. Position three pieces of heat shrink tubing (66-47062-001) on the auxiliary BCA cable with one on the upper cable and two on the lower cable.
NOTE: Position the heat shrink tube to allow enough room to complete the butt crimp process without damaging it. If the heat shrink is damaged and splits during the heating process, the terminal must be replaced to ensure the connection is watertight.
29. Crimp the butt connector.
 - a. Remove the cable insulation equal to half the butt connector length without damaging the wire strands.
 - b. Straighten any bent conductor strands.
 - c. Fully seat the conductor in the terminal.
 - d. Adjust the crimping tool to the correct cable size.
 - e. Crimp the terminal.

F1029 A-O

Creation Date: May 2026

NHTSA #26V-079

Transport Canada #2026-054

30. Insulate the butt connection with heat shrink sleeves. See Fig. Fig. 163.

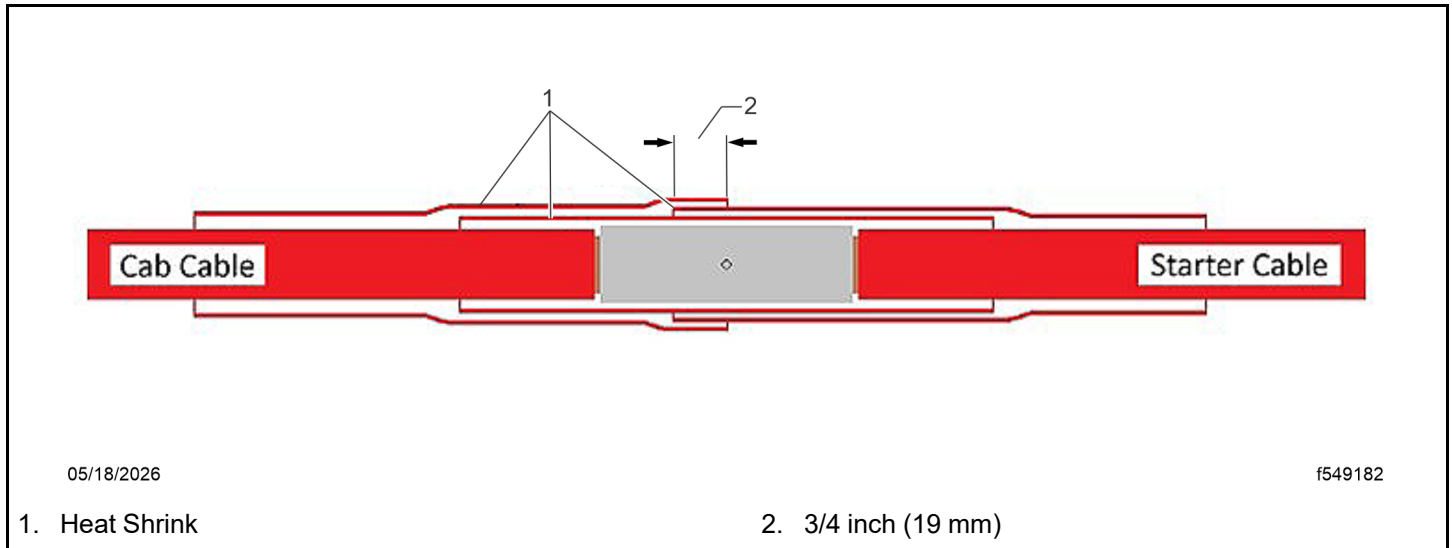

Fig 163, Heat Shrink Insulation

- a. Center the first piece of heat shrink sleeve on the terminal.
 - b. Activate the sleeve by heating it evenly from one end until it adapts to the size of the cable and the adhesive liquefies.
 - c. Continue heating the sleeve on all sides, working from one end to the other.
 - d. Confirm a continuous ring of adhesive can be seen around the circumference of the sleeve at both ends.
 - e. Position the second sleeve on the lower cable and overlap the center of the first sleeve by 3/4 inch (19 mm).
 - f. Activate the second sleeve by heating it evenly from one end until it adapts to the size of the cable and the adhesive liquefies.
 - g. Continue heating the second sleeve on all sides, working from one end to the other.
 - h. Confirm a continuous ring of adhesive can be seen around the circumference of the second sleeve at both ends.
 - i. Position the third sleeve on the upper cable and overlap the top of the second sleeve by 3/4 inch (19 mm).
 - j. Activate the third sleeve and inspect for a continuous ring of sealant at both ends.
31. Cover the heat shrink joint with convolute tubing. If extra convolute tubing is required, use 4/0 Red Slit Convolute (48-25360-022) for 4/0 cables, and CONDUIT-NYL, 19MM, FLEX (48-25360-019) for 2/0 cables.
32. Apply red electrical tape to the cable and to the convolute end to create a seamless transition between the ends of the convolute.

F1029 A-O

Creation Date: May 2026

NHTSA #26V-079

Transport Canada #2026-054

33. Install the upper and lower cable clamps on the isolator frame bracket. To prevent cables (A) from rubbing, secure any cables routed on the outside cable clamps (B) using butterfly cable ties (C) (TYCDCT110HIR). See Fig. **Fig. 164**.

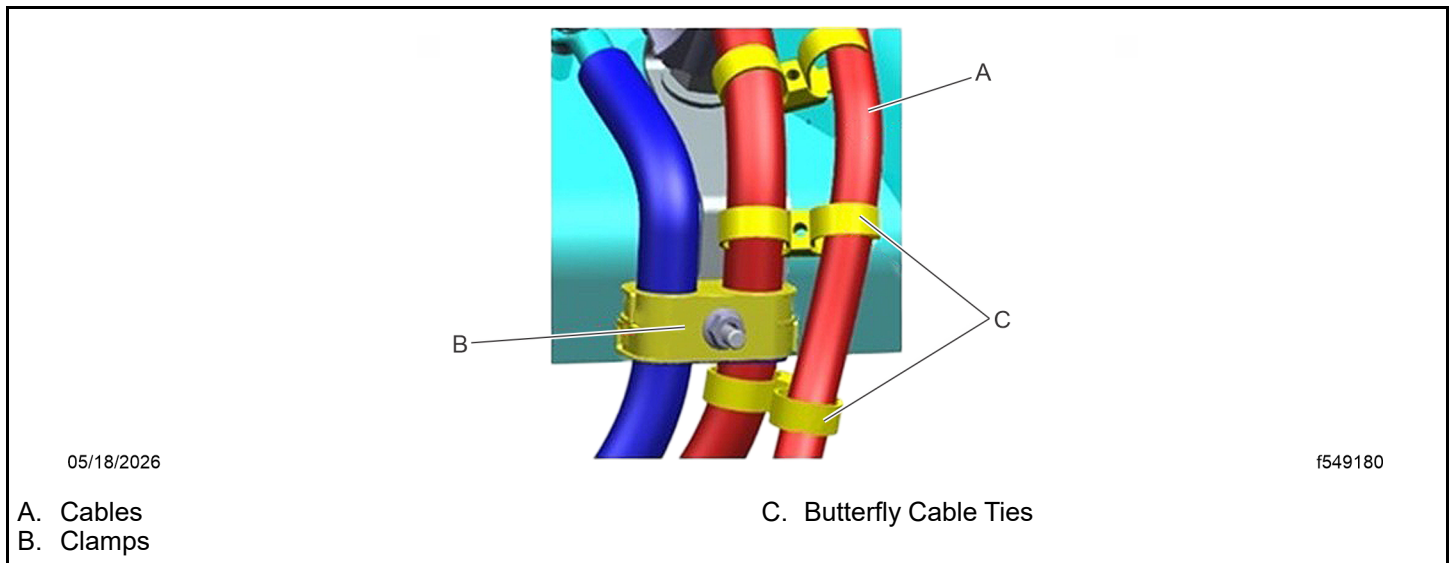

Fig 164, Butterfly Cable Ties Around the Cable Clamps

34. Secure the cables to the 5/8 inch (16 mm) tie block with a Heavy Duty (HD) cable tie (23-13476-000) and other points where positive power cables are routed together.
35. Use butterfly cable ties (TYCDCT110HIR) to route positive cables next to any other cables or anywhere along the path where cables must be separated.
- IMPORTANT: Ensure no power cables are rubbing, or close to rubbing, the frame or engine components.
36. If removed, install the splash shield behind the front tire. For detailed instructions, see Group 88 of the *47X, 48X and 49X Workshop Manual*.
37. Install the negative cable connections at the batteries.
38. Clean a spot on the base label (Form WAR259) and attach a campaign completion sticker for F1029 (Form WAR260).

F1029 A-O

Creation Date: May 2026

NHTSA #26V-079

Transport Canada #2026-054

Groups N and O Work Instructions

1. For vehicles in Groups N and O, please file a PRISM Network Assist (PNA) ticket to the warranty campaigns department.