



Service Bulletin

American Honda Motor Co., Inc.

CBR650R/RA #1
Revised: February 2026

SAFETY RECALL

2024 - 2025 CBR650R/RA WIRE HARNESS SHORT CIRCUIT

(This bulletin has been revised to include repair information for ALL affected units.)

NEW

BACKGROUND

Honda is issuing a **SAFETY RECALL** for **CERTAIN** 2024–2025 CBR650R/RA motorcycles. During normal use, vehicle vibration and friction can cause the turn signal switch wire harness insulation to wear against the left-side middle cowl bracket, exposing the copper core, causing an electrical short and blown fuse. If the fuse is blown, the motorcycle’s turn signal, brake, and license plate lights, speedometer, and horn will not function, preventing the rider’s ability to observe the speed and alert other drivers of the rider’s actions/intended actions, increasing the risk of a crash or injury.

AFFECTED UNITS

As of December 19, 2025, you **MUST NOT SELL ANY NEW or USED** 2024 or 2025 CBR650R/RA motorcycle until it is repaired according to this service bulletin.

- To search for applicable recalls on a specific unit, you **MUST** use *Unit Information* on **iN**.
- To manage your affected new inventory, use your dealer *eResponsibility Report* on **iN**.

CUSTOMER NOTIFICATION

American Honda intends to mail customer letters to all owners of affected motorcycles in February 2026. Customers will be informed that their motorcycle is affected by this safety-related defect and to make an appointment with an authorized Honda dealer to have their unit repaired. A copy of the customer letter is shown at the end of this service bulletin.

PARTS AVAILABILITY

Repair parts are under TechLine control. If an affected unit fails the inspection and requires wire harness replacement, submit a TechLine Connect as described on [page 7](#). Many of the individual parts provided in the wire harness kit are included in case the original fasteners are lost or damaged. The part numbers are provided only for part location purposes using the parts catalog.

Part Name	Part Number	Qty.
KIT, HARNESS WIRE	06321-MKY-LA0	1
The kit includes the following parts (Do not order these parts):		
Rivet, Push 6 mm (shorter)	90116-K0A-E11	2
Rivet, Push 6 mm (longer)	90116-K3V-N11	2
Screw, Pan 5 mm	91508-MM5-000	2
Screw, Pan 5 x 16 mm (silver)	90134-MJE-D00	1
Screw, Pan 5 x 16 mm (black)	90133-MKN-D50	1
Fastener F, Dual Lock, 20 x 20 mm	17543-MJE-DB0	2
Fastener A, Dual Lock, 8 x 25 mm	17540-MJE-D00	2
Seal, Throttle Body	17215-MJE-D00	2
Harness, Wire	32100-MKY-LA0	1

DEALER REPAIR RESPONSIBILITY

- Repairs must be performed by a qualified technician.
- Performing this repair exactly as shown in Repair Procedure instructions is critical for the remedy to be effective. Carefully follow all instructions.
- Service Management should inspect and confirm the repair.
- Dealer submission of a warranty claim affirms this repair was properly performed.

1 of 20

WARRANTY CLAIM INFORMATION

After completing the appropriate *Service Bulletin* repair, submit one warranty claim per unit with the applicable template number.

YEAR	MODEL	TEMPLATE	FLAT RATE
2024 2025	CBR650R/RA	Re-route Wire Harness KT7A	0.6 hr
		Apply Electrical Tape & Re-route Wire Harness KT7B	0.7 hr
		Replace Wire Harness KT7C	5.3 hr

Notes:

- The KT7B warranty template claims includes costs to cover electrical tape.
- The KT7C warranty template claim will reimburse freight. To ensure your dealership receives the freight credit, follow these steps.
 1. Make sure 'YES' is selected from the *Freight Involved* drop down window.
 2. Make sure to include the *Part Order Reference Number*.
 3. Include the freight *Amount* associated with the listed *Part Order Reference Number*. The *Part Order Reference Number* can be found on your *Parts Order Statement* on *iN*.

• = Required

Template Warranty Claim

Template Number*

Basic Claim Information (required for all claim types)

Claim No.* Repair Order Number*

VIN* Repair Order Date (open)* / / 2023

Mileage* Work Completed Date* / / 2023

Sublet Involved?

Freight Involved? Freight Information

Part Order Reference Number* Amount

DEALER SUPPORT

TECHNICAL QUESTIONS

If you have any technical questions relating to this update procedure, please contact: Motorcycle TechLine Online:

iN > Service > TechLine > TechLine Connect

WARRANTY QUESTIONS

If you have any warranty administration questions relating to warranty claim templates, and claim filing procedures, please contact:

Motorcycle Warranty Online:

iN > Service > Warranty & HondaCare > Warranty Connect Filing

Or call (800) 421-1900, option 7

RECALL REPAIR IDENTIFICATION

Before you begin the repair procedure, verify that the unit has not already been repaired by searching *Unit Information* on *iN*.

REPAIR PROCEDURE

Complete the inspection procedure below on all units, and then determine which type of repair is required, as described on [page 4](#).

Inspection Procedure

Remove the lower inner cowl:

1. Remove the trim clips [1].
2. Remove the projections [2] from slots [3], remove the
3. lower inner cowl [4].

Installation is in the reverse order of removal.

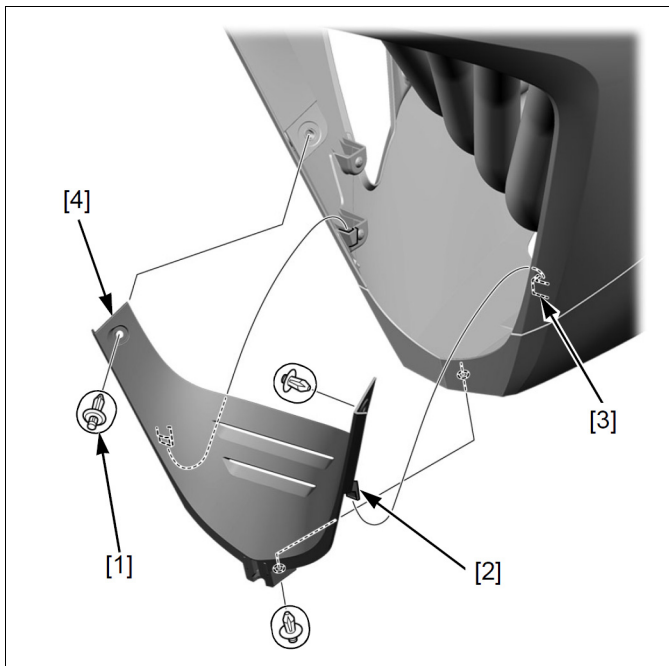

Remove the left middle cowl.

Remove the following:

- Trim clips [1]
- Two Pan Screw 5x16mm (Black) [2]
- Two Pan Screw 5x16mm (Silver) [3]

Disconnect the gray front turn signal light 2P connector [4], then remove the middle cowl [5].

Installation is in the reverse order of removal.

TORQUE:

Pan Screw, 5 x 16 mm:

0.42 N·m (0.04 kgf·m, 0.3 lbf·ft)

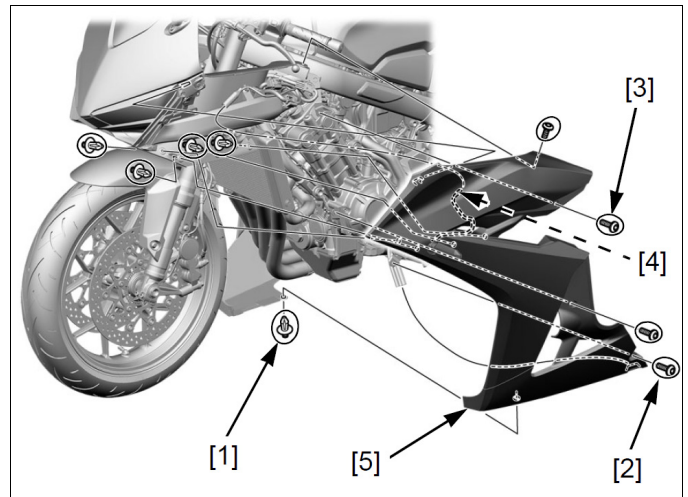

Locate the Left Handlebar Switch Harness [1].

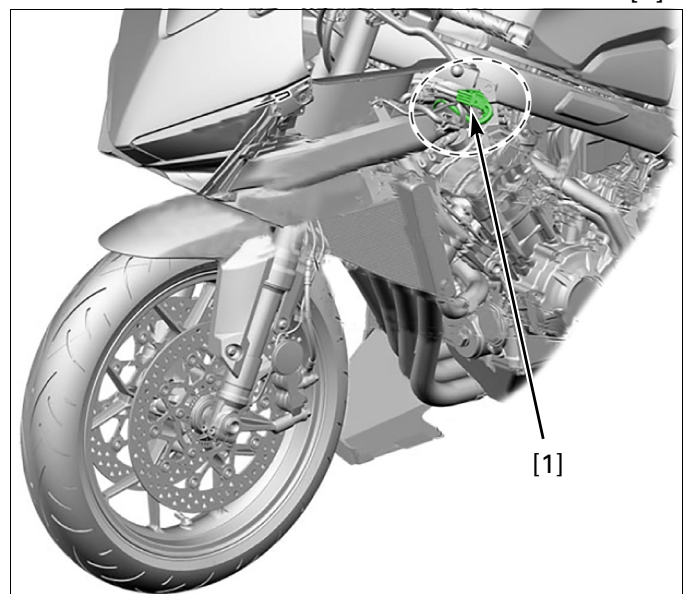

Inspect the Left Handlebar Switch Harness following the steps below to ensure there is ZERO wear or damage on the harness tape or wires near the middle cowl stay.

1. Disconnect the 8P Left Handlebar Switch connector.
2. Inspect the wire harness insulation in the location shown for signs of damage to the wire harness tape or wires.

If you are unsure about the damage shown, take clear photographs of the damage on the harness and submit a *TechLine Connect*. See **TECHLINE CONNECT - PHOTOGRAPH UPLOAD PROCEDURE** on [page 19](#) for details.

- If there is no damage whatsoever to the harness, go to **Repair A** on [page 5](#).

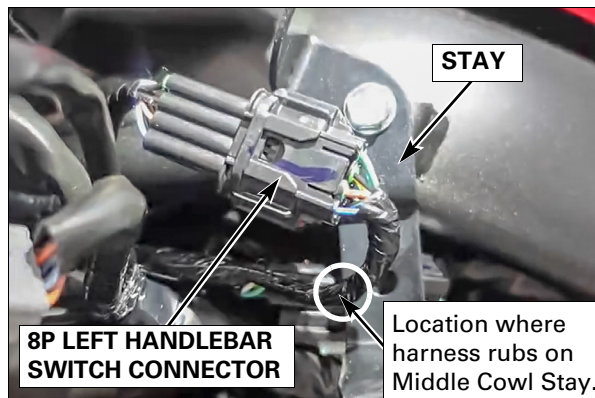

- If there is wear or damage to the harness tape only, and there is no damage to any wire insulation, and no copper wires are visible, go to **Repair B** on [page 6](#).



- If there is visible damage to any wiring insulation, or the stranded copper wiring is visible or broken, go to **Repair C** on [page 7](#).

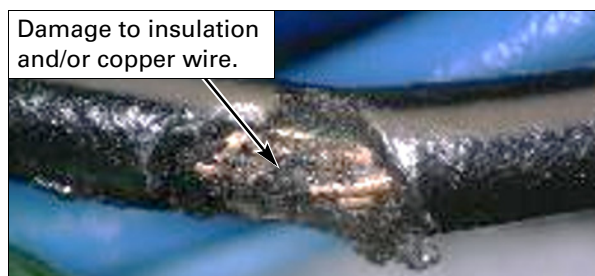
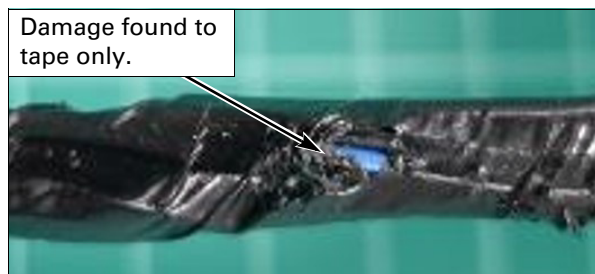

REPAIR A

If no damage was found on the switch harness tape, reroute the harness following the steps below, and then file a **KT7A** warranty claim using the information shown in WARRANTY CLAIM INFORMATION on [page 2](#).

1. Route the 8P Left Handlebar Switch harness and connector (highlighted in green) underneath the front sub harness (highlighted in yellow).
2. Ensure the 8P Left Handlebar Switch harness and connector are routed in front of the 4P Left Front Turn Signal Switch Harness (highlighted in blue).
3. Slightly untwist and re-situate the Front Sub Harness, as demonstrated in the video link below.
4. Reconnect the 8P Left Handlebar Switch Harness connector.
5. Be sure the 8P Left Handlebar Switch harness does not contact the Left Middle Cowl stay.
6. Reassemble the motorcycle in the reverse order of disassembly.

VIDEO: [Click here to view a video of the repair](#)

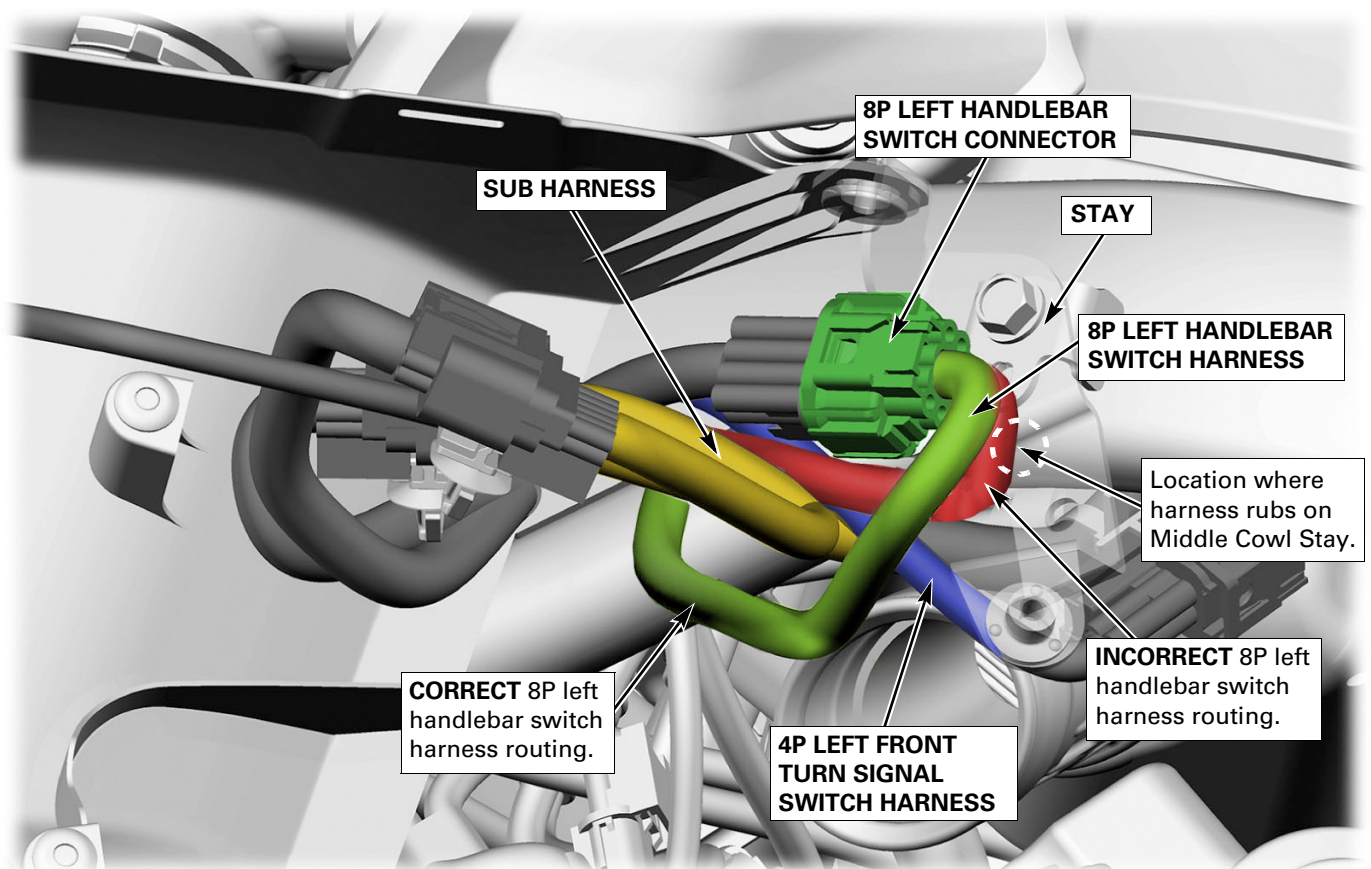

REPAIR B

If there is wear or damage to only the harness tape, and no damage found on the wire insulation or stranded copper wire, apply additional electrical tape to the area shown, and then reroute the harness following the steps below. File a **KT7B** warranty claim using the information shown in WARRANTY CLAIM INFORMATION on [page 2](#).

Note: While Repair B does not require a TechLine Connect case, if you are unsure about the extent of the harness damage, you may submit photos to TechLine for confirmation. See [page 19](#) for details.

1. Wrap new electrical tape over the existing harness tape:

- The new tape should extend 30 mm (1.2 in.) on both sides past the location where the damaged tape was found.
- Wrap the tape around the harness at least two or three times to ensure a proper protective covering for the wires.

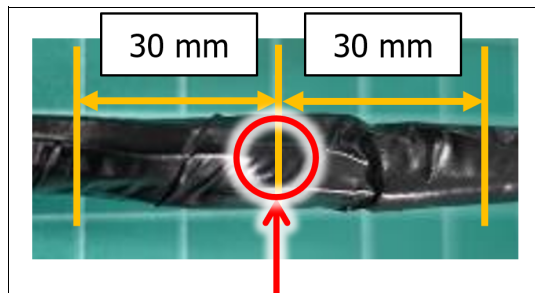

2. Route the Left Handlebar Switch harness and 8P connector (highlighted in green below) underneath the front sub harness (highlighted in yellow).

3. Ensure the Left Handlebar Switch harness and 8P connector are routed in front of the 4P Left Front Turn Signal Switch Harness (highlighted in blue).

4. Slightly untwist and re-situate the Front Sub Harness, as demonstrated in the video link below.

5. Reconnect the 8P Left Handlebar Switch Harness connector.



6. Be sure the Left Handlebar Switch harness does not contact the Left Middle Cowl stay.

7. Reassemble the motorcycle in the reverse order of disassembly.

VIDEO: [Click here to view a video of how to reroute the harness.](#)

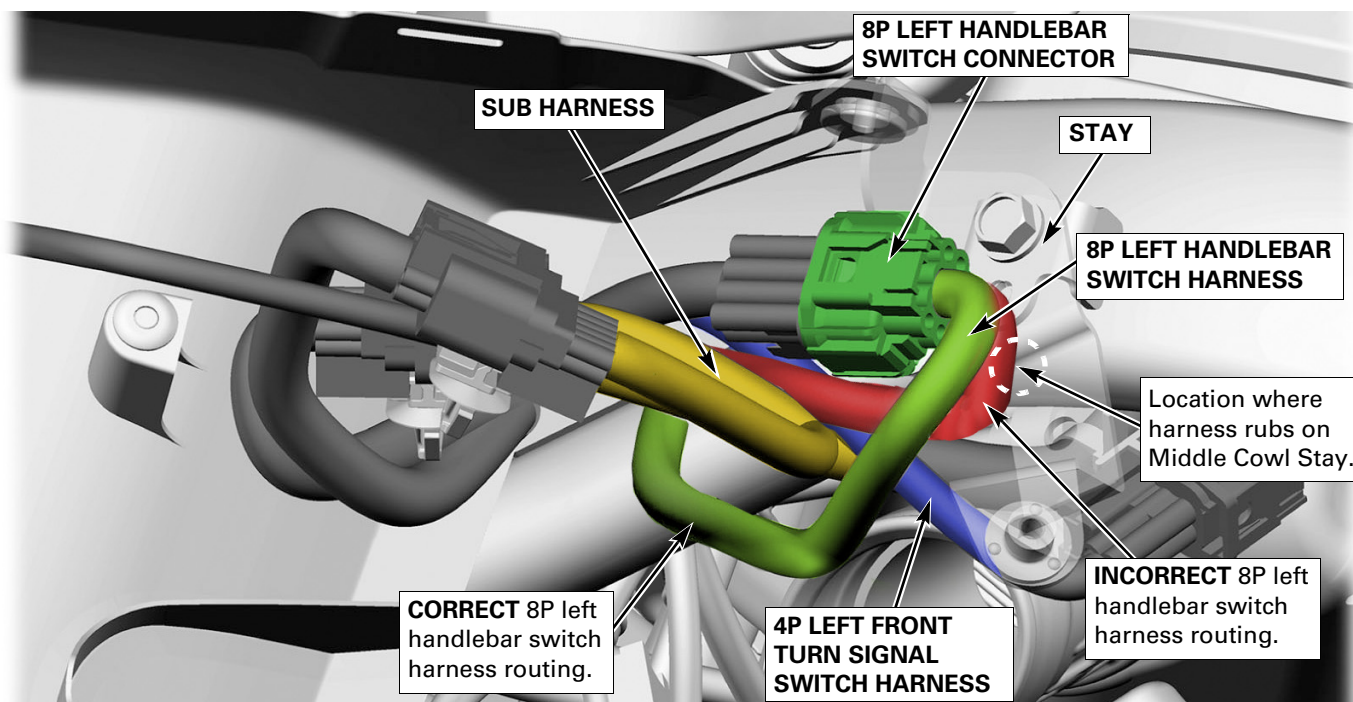

REPAIR C

If there was any wear or damage found on the wire insulation or stranded copper wire during the inspection, the main wire harness must be replaced.

Take clear photographs of the damage on the harness and submit a *TechLine Connect*. See **TECHLINE CONNECT - PHOTOGRAPH UPLOAD PROCEDURE** on [page 19](#) for details.

The wire harness kit required for this repair is under TechLine control (see [page 1](#)).

After the repair is complete, file a **KT7C** warranty claim using the information shown in **WARRANTY CLAIM INFORMATION** on [page 2](#).

WIRE HARNESS REMOVAL

1. Remove as much fuel from the fuel tank as possible and save it in a suitable clean container for reuse.
2. Remove the passenger seat by unhooking the passenger seat lock using the ignition key [1], and then pulling the seat [2] rearward.

Apply grease to the passenger seat catch hook sliding area if necessary during reassembly.

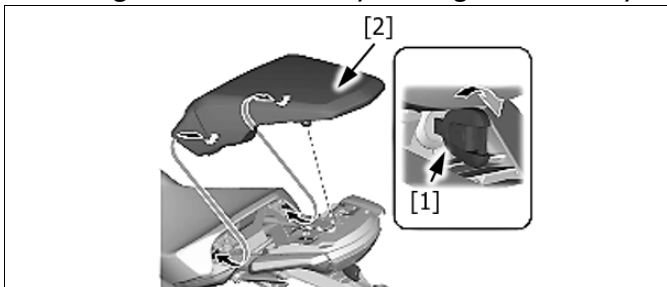

3. Remove the rider seat.
Remove the mounting socket bolts [3] and collars [4].
Remove the rider seat [5] by pulling it rearward.

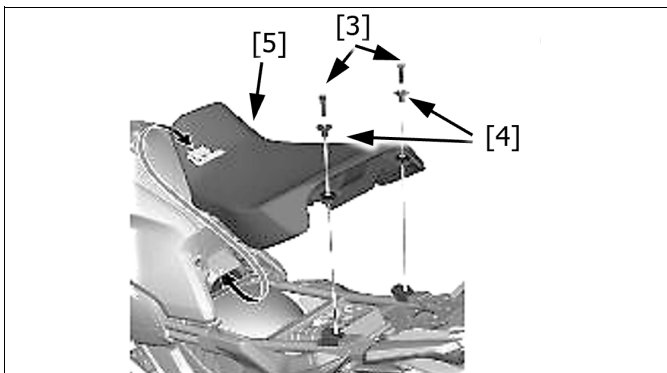

4. Remove the R. and L side cover.
Remove the socket bolts [1].
Release the boss [2] from the grommet [3] of the fuel tank.
Remove the side cover [4] by releasing the tab [5] from the slot [6] of the rear cowl.
Remove the collar [7] and mounting rubber [8].

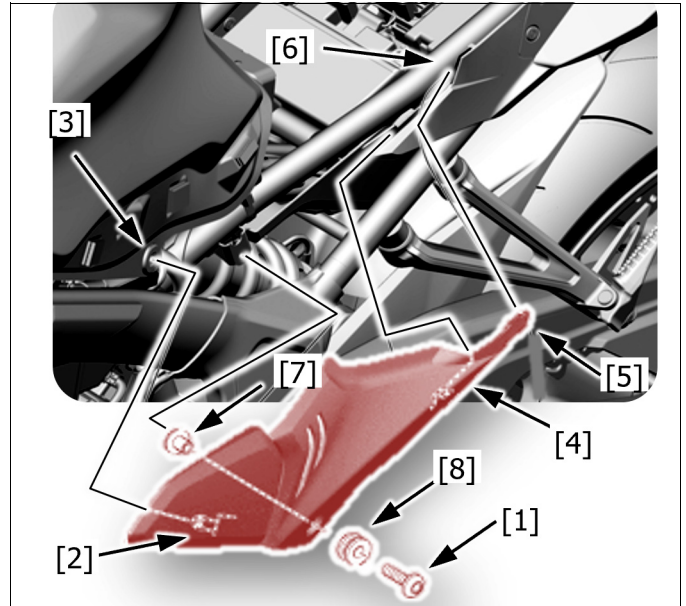

5. Remove the battery.
Turn the ignition switch OFF.
Disconnect the negative (-) cable [9] by removing the terminal bolt.
Disconnect the positive (+) cable [10] by removing the terminal bolt.
Remove the rubber strap [11] and battery [12].

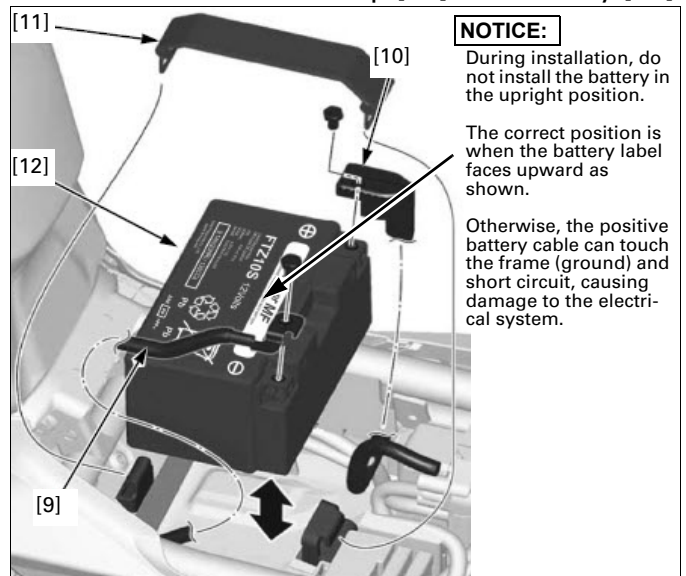

6. Remove the rear cowl.

- Remove 4 socket bolts [1]
- Remove 4 trim clips [2]
- Remove Rear cowl Assy. [3]

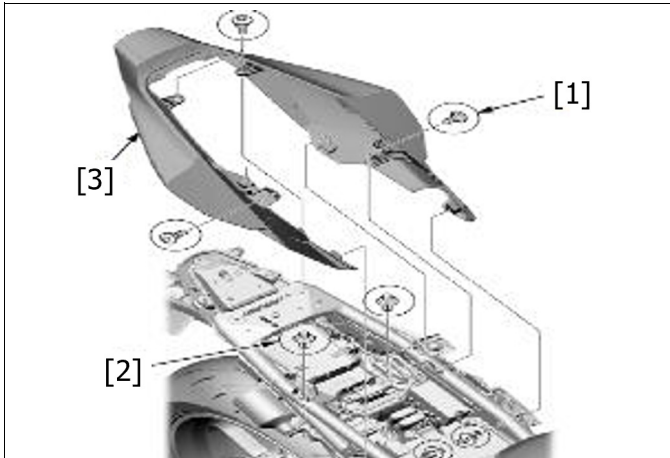

7. Remove the rear fender stay.

Disconnect the following connectors [1]:

- Rear turn signal light 2P (left: Orange, right: Light blue)
- Brake/taillight 3P
- License light 2P
- Remove the bolts [2] and rear fender stay [3] by pulling the wires out from the holes [4] of the rear fender B.

Bolt Torque: 15 ft-lb (21 N•m)

- Disconnect the starter relay switch 2P (Black connector) [5]

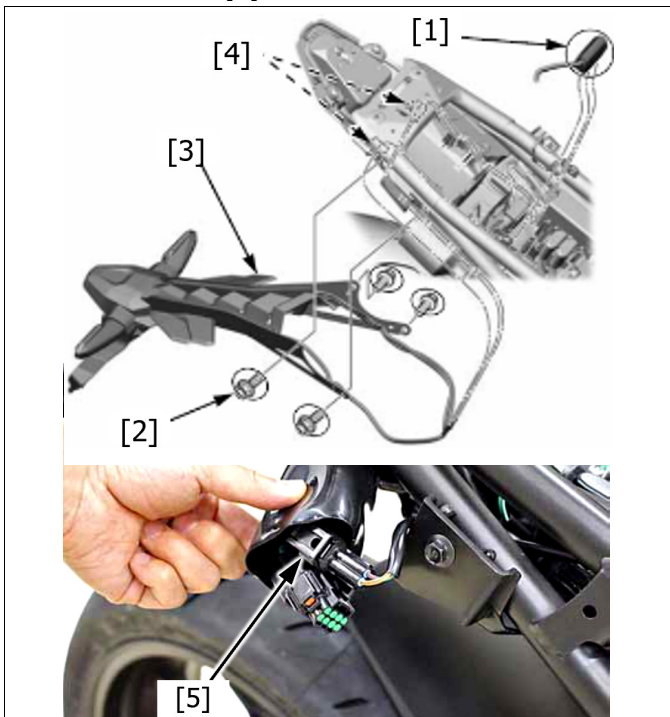

8. Remove the fuel tank front cover assembly.

Remove the two socket bolts [1].

Remove the boss [2] and hook [3], remove the tank cover.

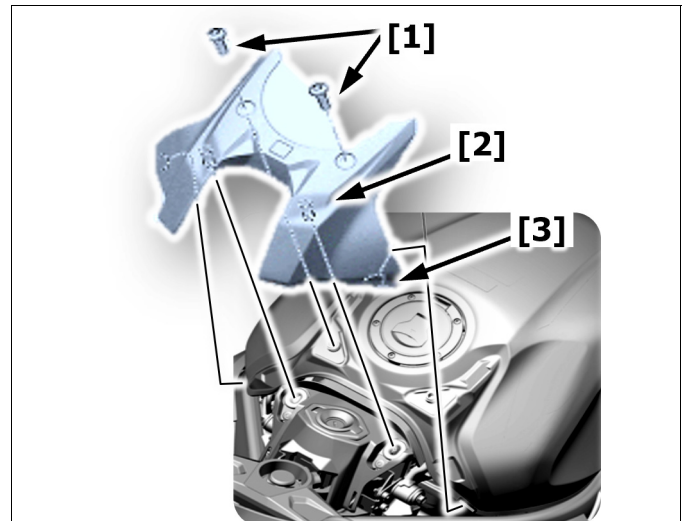

9. Remove the comp switch cover.

- Remove the clip, BPR seal [4]
- Remove the COVER,COMB SW. [5].

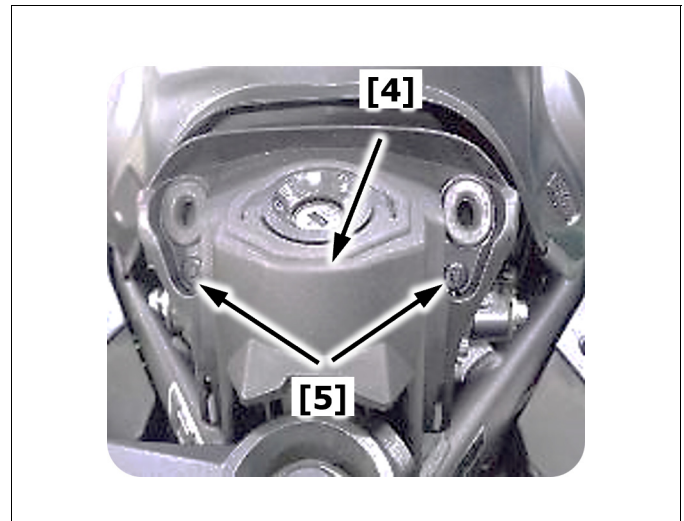

10. Temporarily lift the fuel tank. You must use protective sheet cloth to prevent scratching the tank and surrounding painted areas.

Remove the left and right 6x40 flange bolts [1].

6 x 40 mm Bolt Torque: 7 ft-lb (10 N•m)

Lift the fuel tank [2] using a 10mm T-handle wrench [3] to support it, as shown.

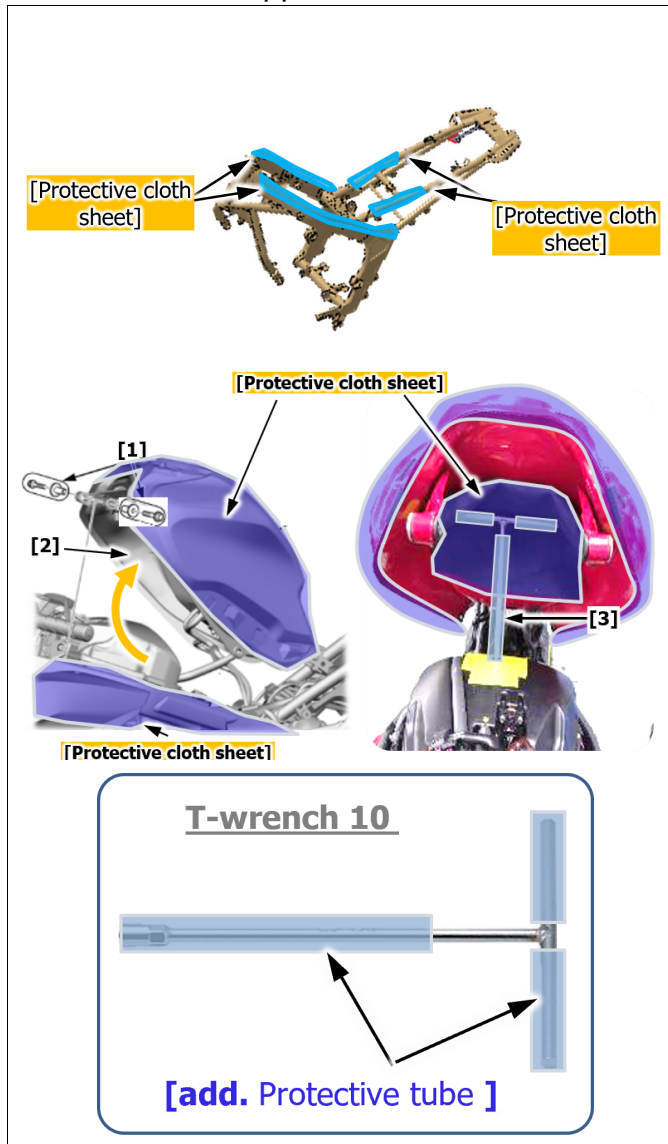

11. Remove the fuel tank.

- Make sure the fuel hose retainer is not stuck.
- Be careful, fuel may spray out when disconnecting the fuel feed hose.
- Be careful not to scratch the fuel tank or any other parts.

Disconnect Fuel tank drain hose [1].

Disconnect fuel tank-to-EVAP canister hose [2].

Disconnect Fuel feed hose [3].

Push the retainer tab [3.1] forward.

Press down the retainer [3.2] and hold.

Disconnect the connector [3.3] from the fuel pump joint.

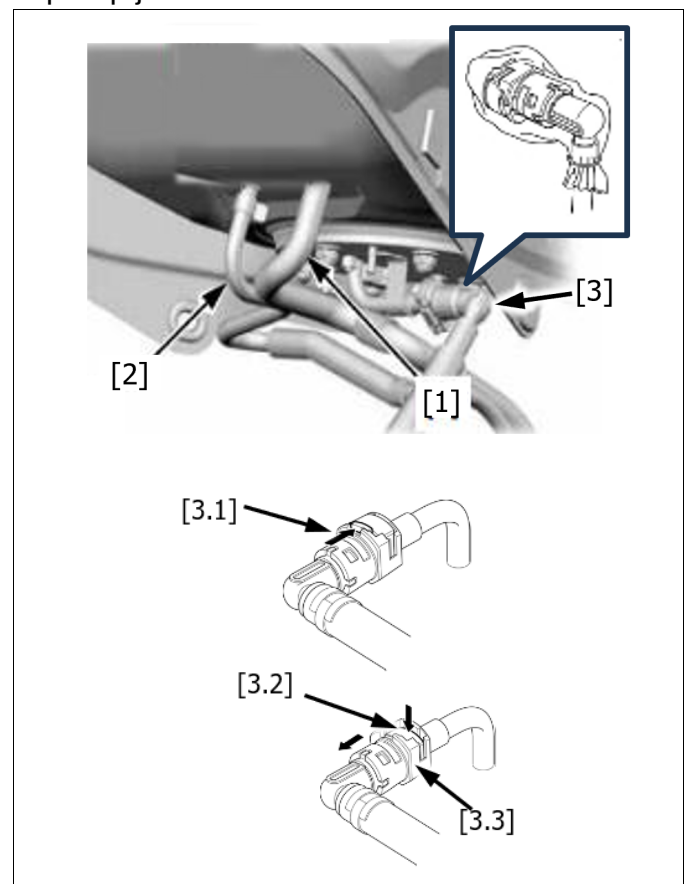

Remove the nut [4], washer [5], bolt [6] and fuel tank [7].

Nut Torque: 9 ft-lb (12 N•m)

Remove the wire band [8].

Disconnect the fuel pump 3P (Black) connector [9] and remove it out of the rear fender B.

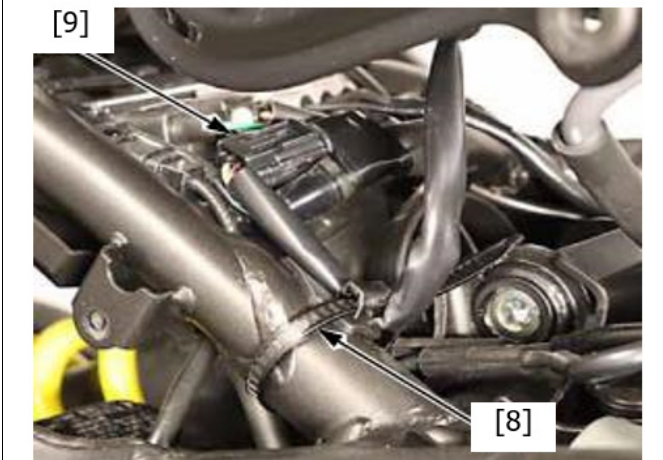
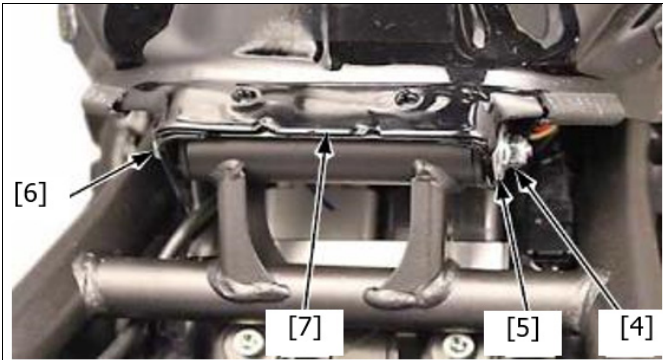

12. Remove the ABS modulator cover.

Release the radiator siphon hose [1] from the wire guides [2].

Remove the two clips [3].

Remove the ABS modulator cover [4] by releasing the tab [5] of the ABS modulator tray from the slot [6].

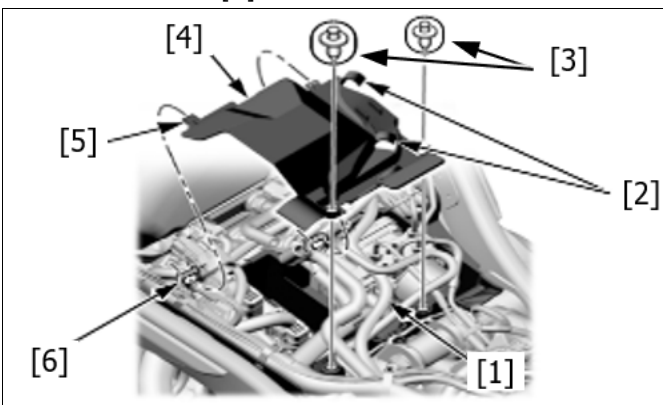

13. Remove the starter relay nuts [1], and then remove the starter relay from rear fender B [2].

Remove fuse box [3] out off rear fender B [4].

Nut Torque: 3.6 ft-lb (4.9 N•m)

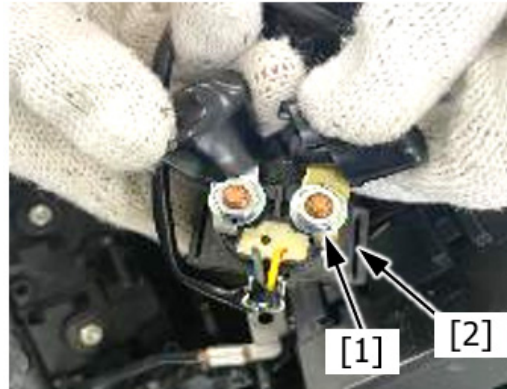

14. Remove the regulator/rectifier.

Disconnect the regulator/rectifier 3P (Black) [1] and alternator 3P (Gray) [2] connectors.

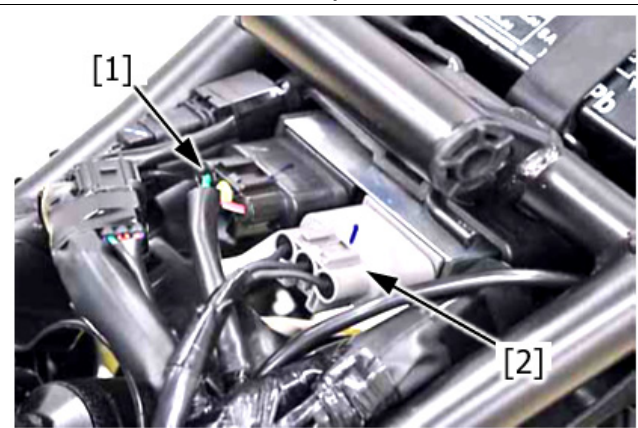

15. Disconnect cable seat lock [1] out of key seat lock [2].

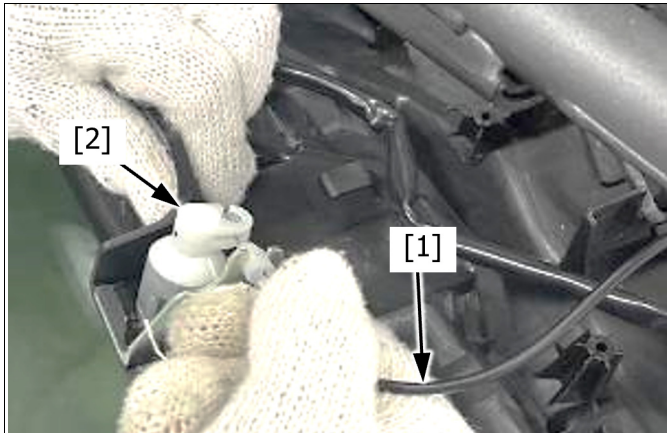

16. Remove Rear Fender B.

Remove the two bolts [1].

Release the securing tab from the wire harness that attaches to the front of rear fender B from the underside.

Slide rear fender B [2] downward and remove it out of the frame.

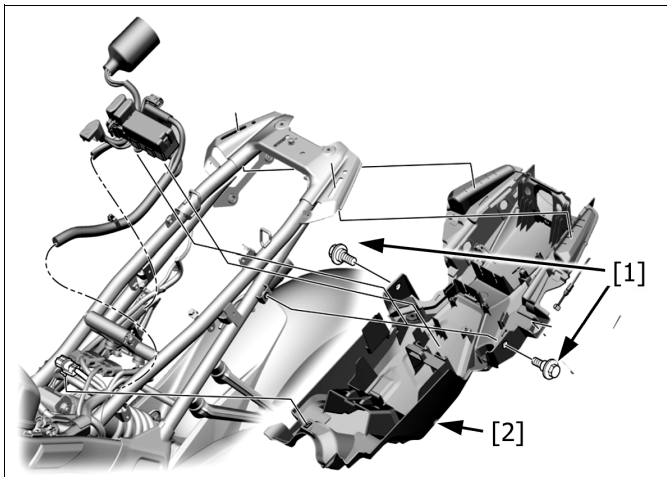

17. Disconnect and remove the air cleaner cover.

Disconnect the IAT Sensor 2P (Black) connector [1]

Disconnect the following from the air cleaner lid [2];

- Crankcase breather hose [3]
- Air supply hose [4]
- Ignition switch 2P (Brown) connector [5]
- Immobilizer receiver 4P (Black) connector [6]
- Wire clip [7]

Remove the nine tapping screws [8] and air cleaner lid [2].

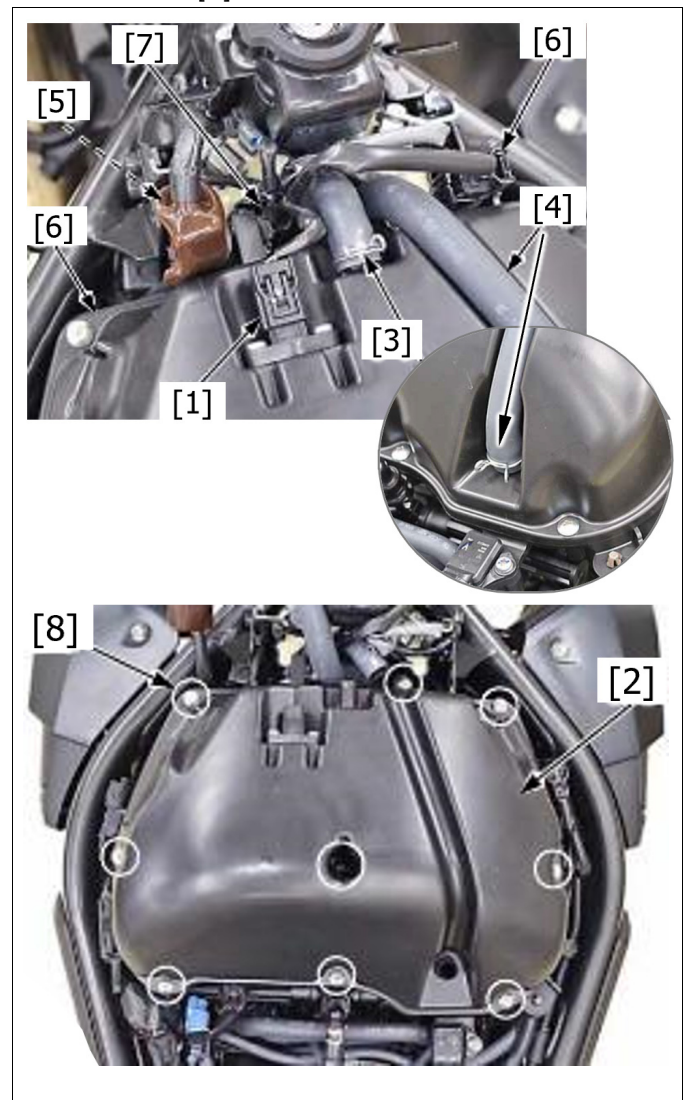

18. Remove the air cleaner element and intake duct.

Apply adhesive tape onto the intake duct to prevent foreign objects from falling into [1].

Remove the 6 tapping screws [2].

Remove the intake duct [3].

Apply adhesive tape to the air cleaner case holes to prevent foreign objects from falling into them [4].

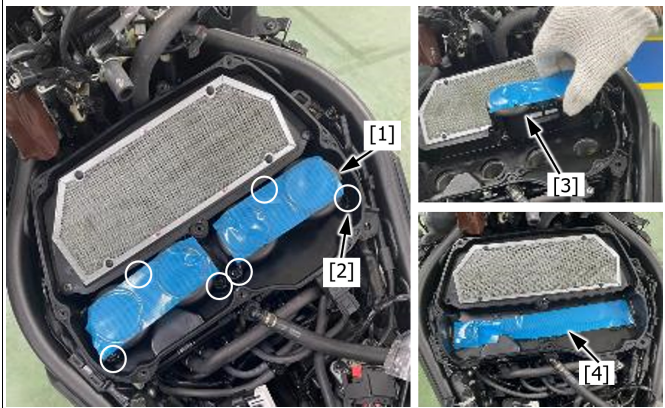

19. Disconnect the following connectors:

Disconnect optional 2P (Black) connector [1] from the air cleaner housing [2].

Disconnect EOP switch 1P (Black) connector [3] from the air cleaner housing.

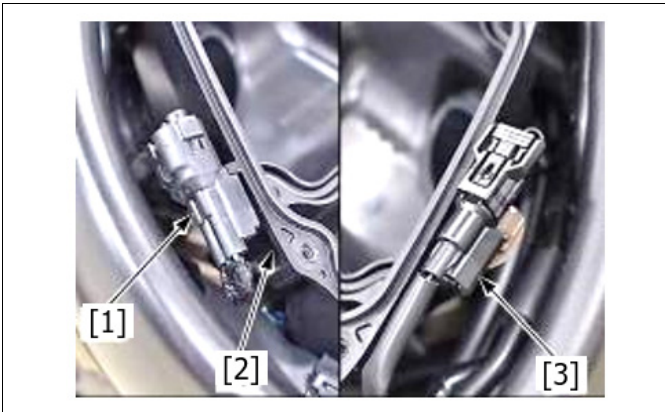

Disconnect wire clip [4].

Disconnect the MAP sensor 3P (Black) connector [5] and vacuum hose [6] from the air cleaner housing.



Remove air cleaner case [7].

Remove PB tube [8] and apply adhesive tape to the throttle body openings to prevent foreign objects from falling into them.

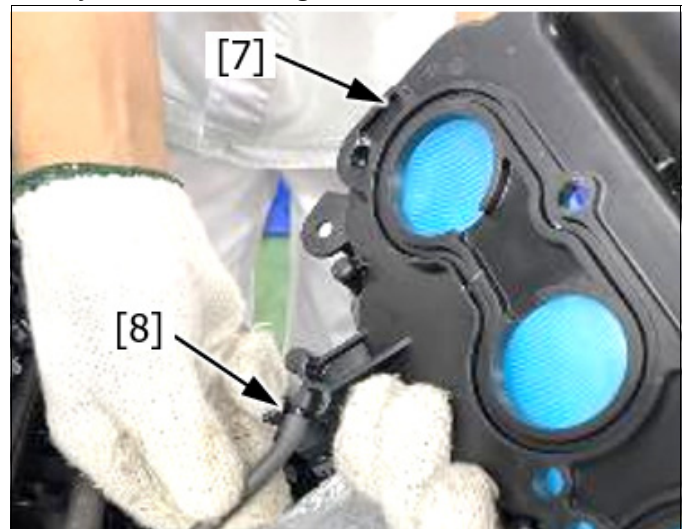

Disconnect Fuel injector sub harness 6P (Black) connector [9].

Disconnect IACV 4P (Black) connector [10].

Disconnect TP sensor 3P (Blue) connector [11].

During installation, replace the throttle body seals on the underside of the airbox with the new parts provided in the wire harness kit.

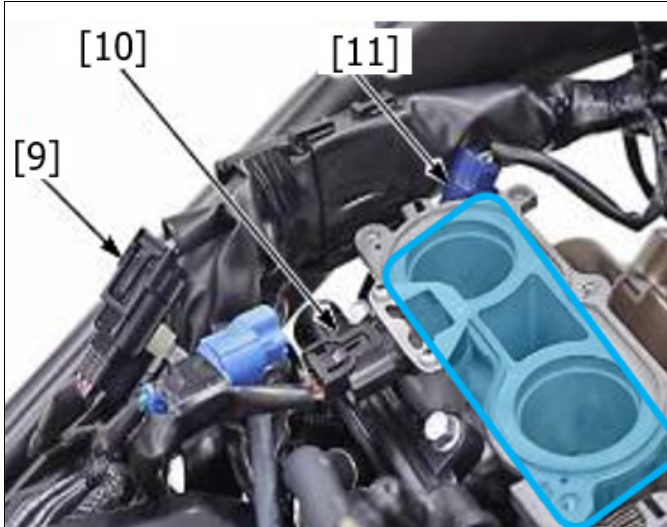

Disconnect the PAIR control solenoid valve 2P (Black) connector [12].

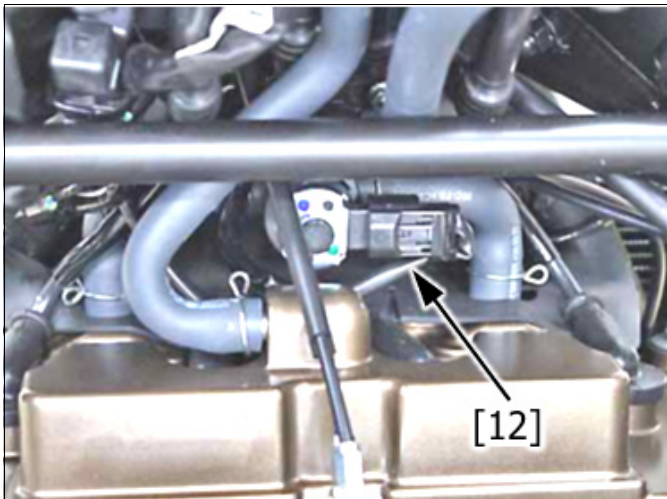

20. Remove both left and right ignition coil assemblies.

Disconnect the only ignition coil wire connectors [1] by without the need to disconnect the spark plug cap

Remove the 4 socket bolts [2] and release the ignition coil stay assembly [3] from the frame.

During Installation:

Ignition coil 1 (Cyl. No.1, 4):

Pink/blue (+) and Ground (-)

Ignition coil 2 (Cyl No.2, 3) [3]:
Pink/black (+) and Ground (-)
[2] Bolt Torque: 7 ft-lb (10 N•m)

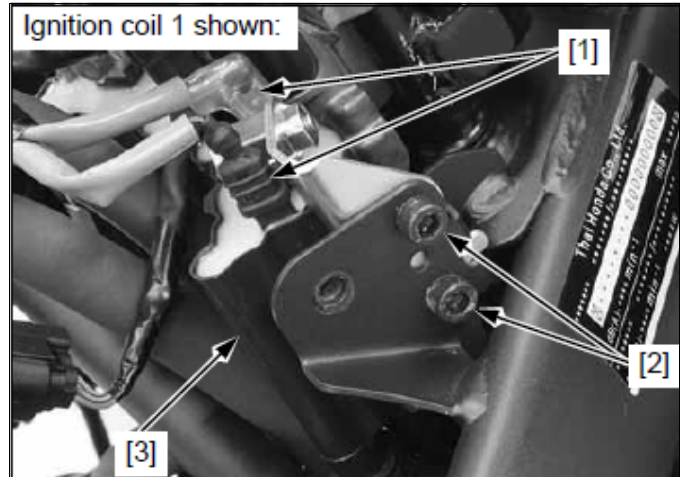

21. Remove the bank angle sensor.

Disconnect the bank angle sensor 2P (Black) connector [1].



22. Remove the following connectors on the right-hand side of the motorcycle.

Disconnect the engine stop switch [1].

Release the front wheel speed sensor 2P (Black) connector [2] from the right intake air duct and disconnect it.

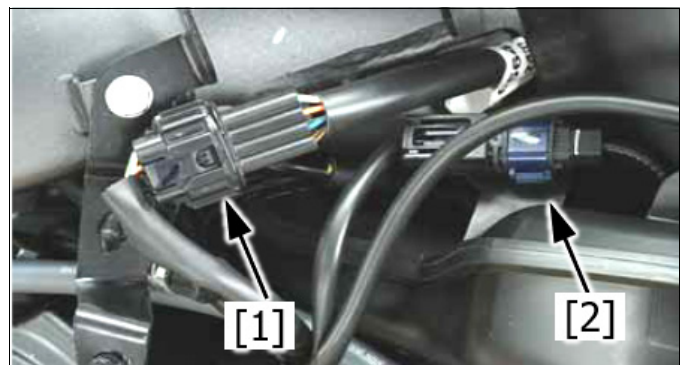

23. Continue by removing the following connectors on the right-hand side of the motorcycle.

Disconnect the left handlebar switch 8P (Black) connector [3], front sub harness 12P(Black) [4] and 12P (Gray) connector[5].

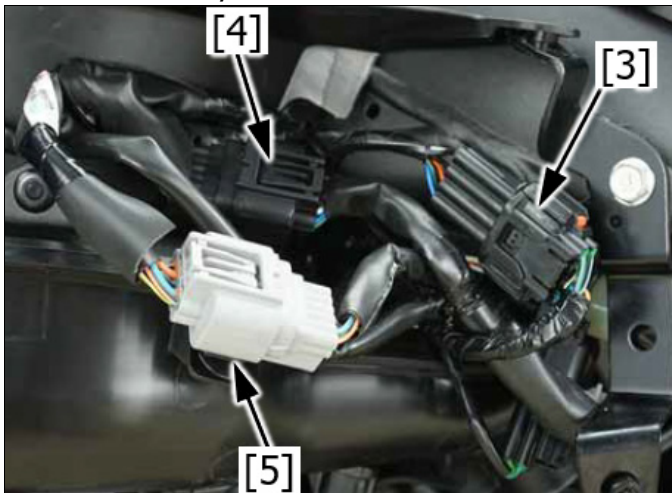

Disconnect the left handlebar switch 4P (Black) connector [6].

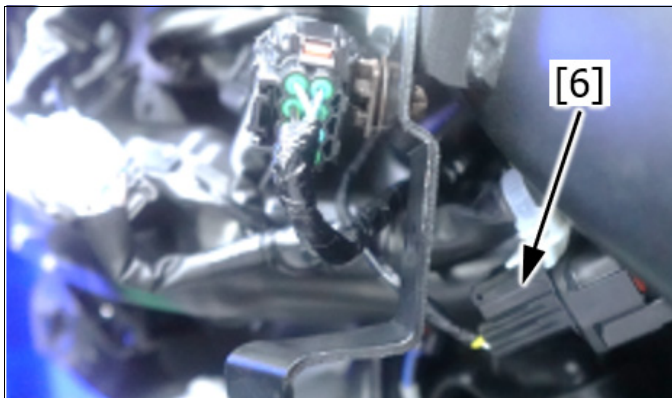

Disconnect rear brake light switch 2P (Black) [7].

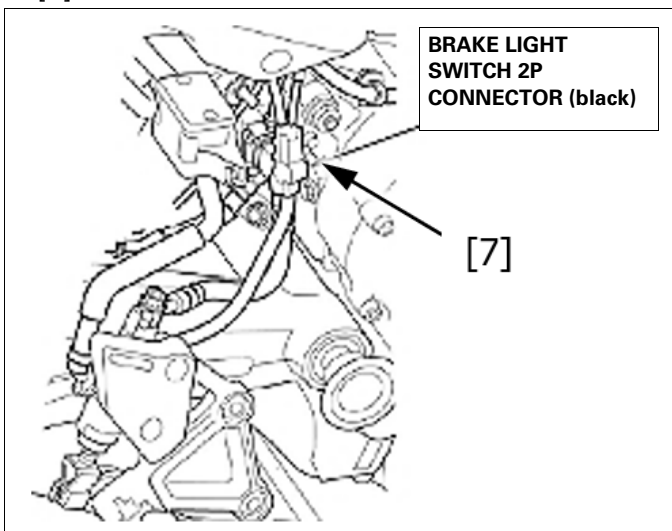

24. Remove the following connectors:

Disconnect the ECT sensor 2P (Blue) connector [1].

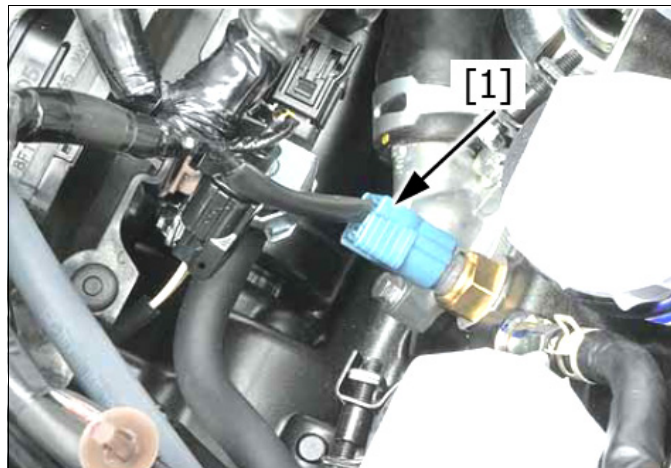

Remove the bolt [2] attaching the frame ground wire terminal.

Ground Bolt Torque: 7 ft-lb (10 Nm)

Disconnect the gear position switch 8P (Black) [3].

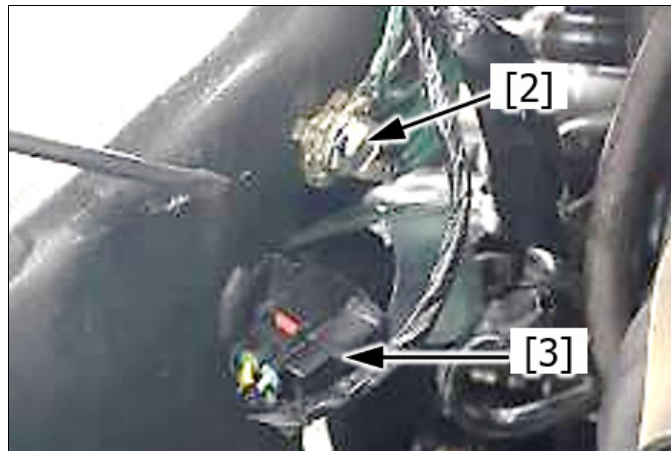

Disconnect the rear wheel speed sensor 2P (Black) connector [4].



Disconnect the connectors [5] from the horn [6].

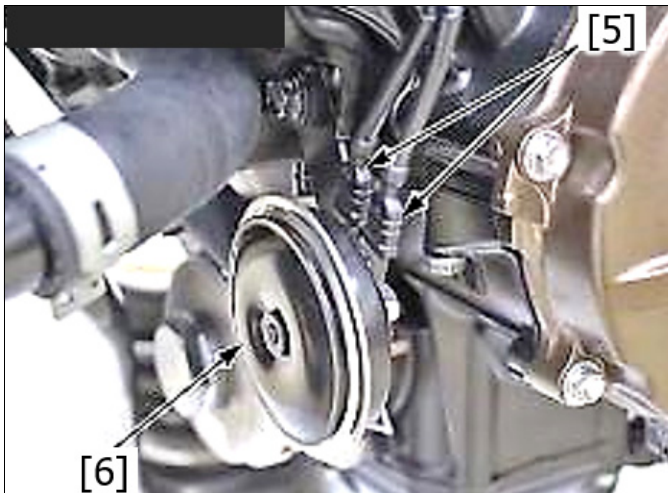

Disconnect the side stand switch 2P (Black) connector [7].

Disconnect the A/F sensor 4P (Black) connector [8] and remove the A/F sensor wire out of the frame.

Disconnect the O2 sensor 4P (Black) connector [9] and remove the O2 sensor wire out of the frame.

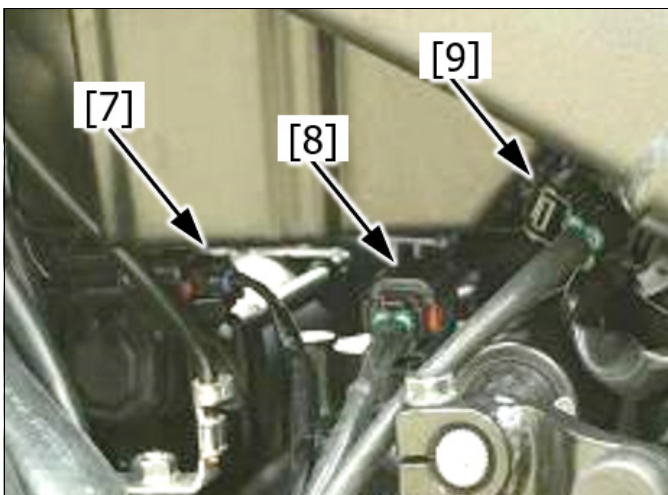

Disconnect the Radiator Fan connector [10] and remove cable tie [11].

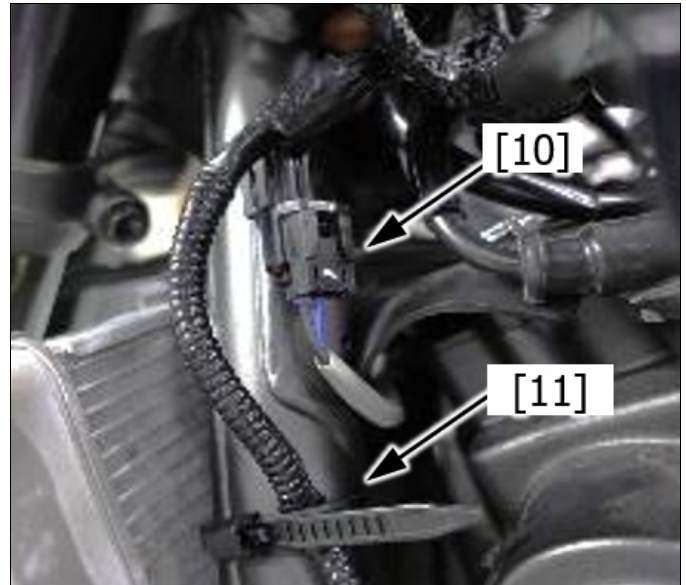

25. Remove the following connectors located on and around the ECM and ABS module tray:

On the 18P ABS modulator connector, turn the lock lever [1] to the side shown while pressing the lock tab [2] to release it.

Be sure the lock lever is turned all the way.

Disconnect the ABS modulator 18P (Black) connector [3].

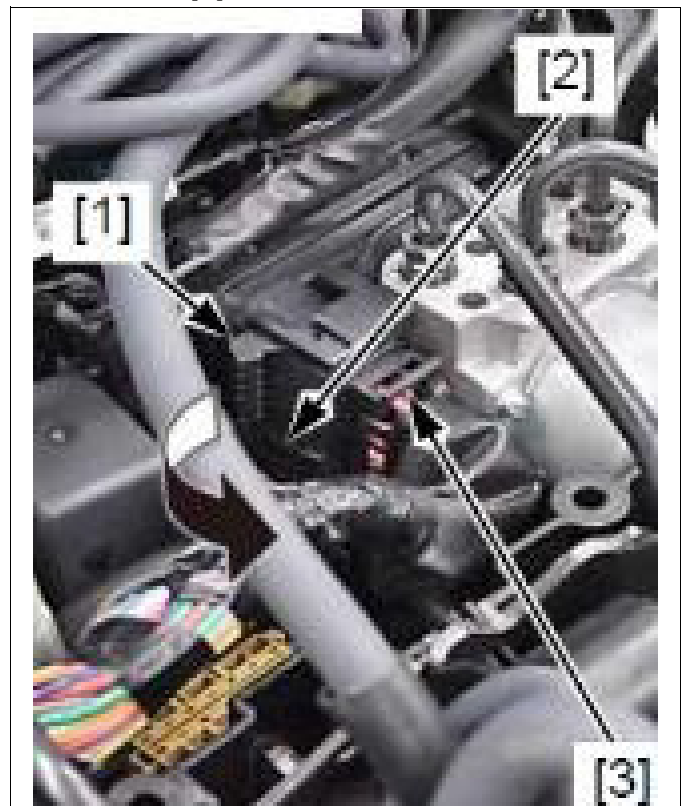

Pull out the ECM [4] from the ABS modulator tray.

Disconnect the ECM 33P (Black) [5] and 33P (Gray) [6] connectors.

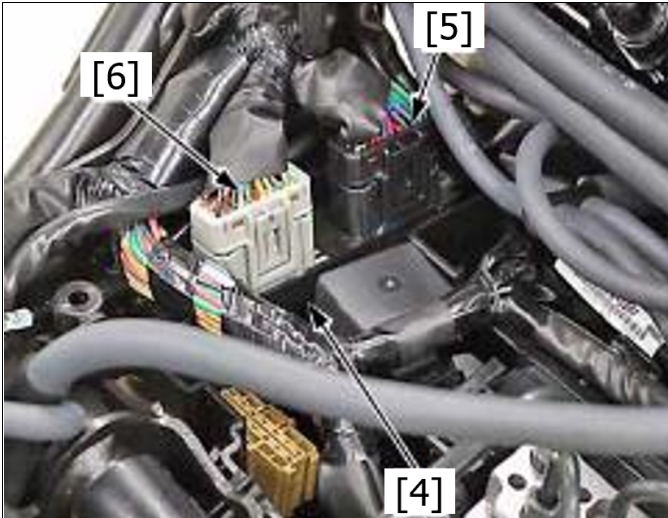

Disconnect the TP sensor 3P (Blue) connector [7].

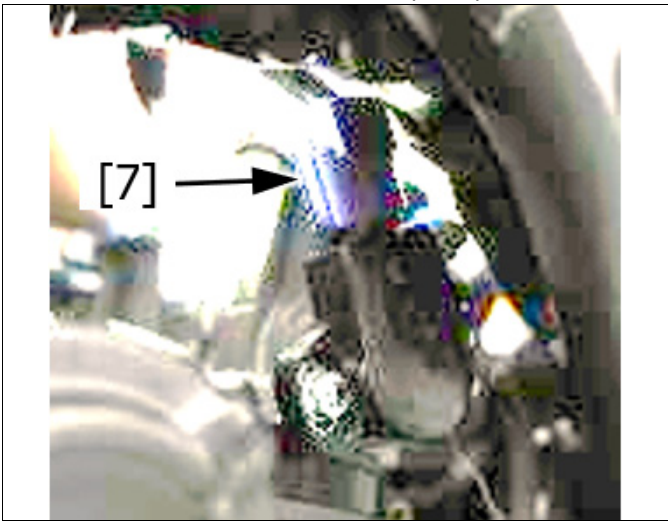

Disconnecting the injector sub harness connector [8].



Remove the winker relay [9] by hand.

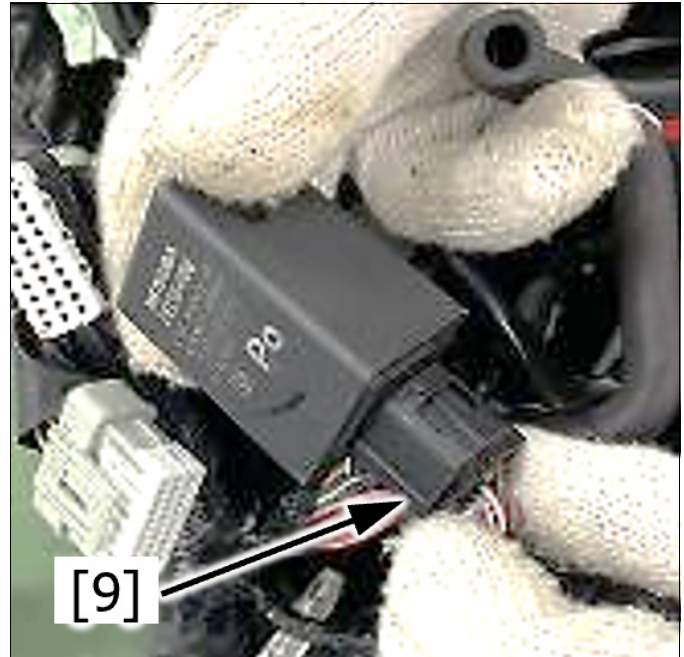

Remove harness wire [10] from the Frame main pipe.

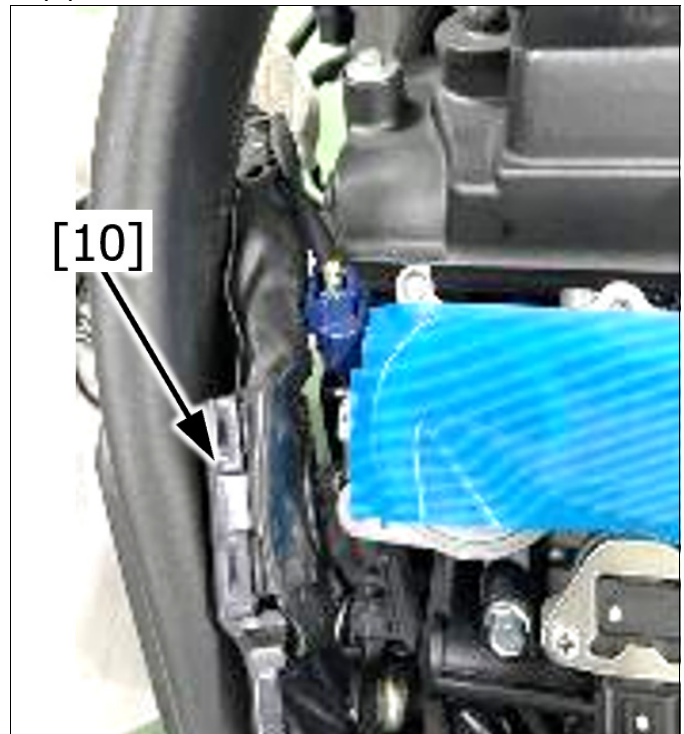

26. Remove the following E-Clutch connectors:

Disconnect the clutch angle sensor 6P (Black) connector [1] and E-clutch actuator 4P (Black) connector [2].

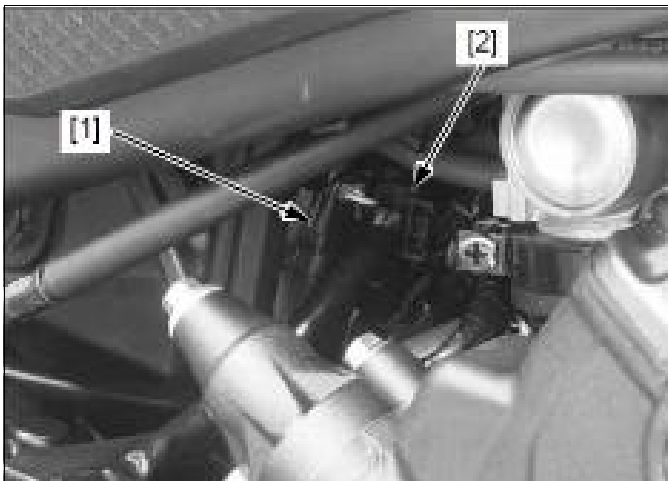

Disconnect the countershaft speed sensor 3P (Black) connector [3].

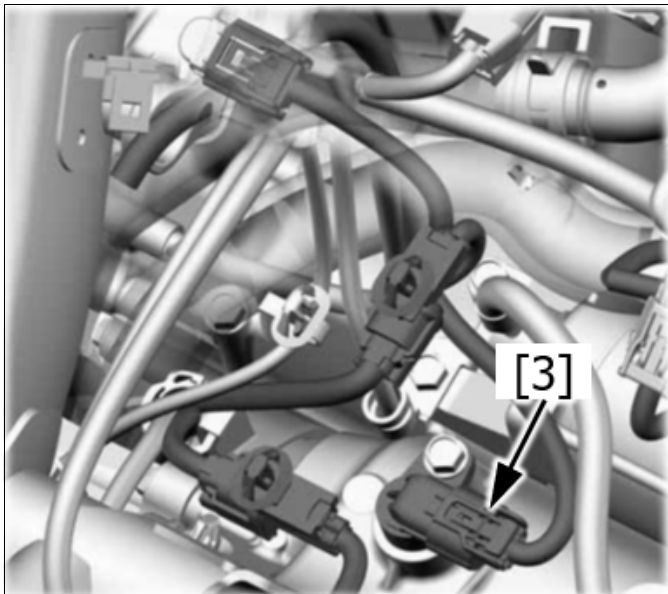

Disconnect the shift stroke sensor 3P (Black) connector [4] and MCU 39P (Black) connector [5].

The wire harness should now be free and can be removed from the motorcycle.

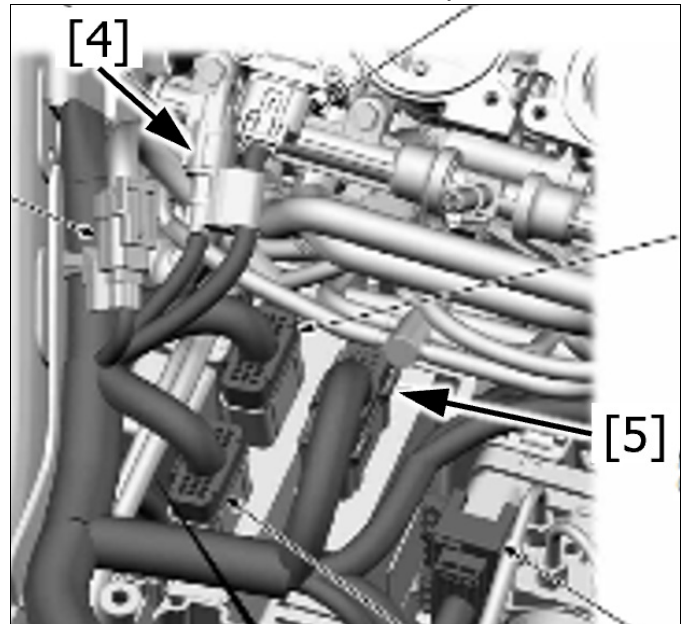

WIRE HARNESS INSTALLATION

Installation is the reverse order of removal.

If necessary, refer to the appropriate Shop Manual for additional help when installing the replacement wire harness.

Pay attention to the torque specs provided throughout the INSPECTION and REMOVAL procedures.

Be sure to replace the throttle body seals with the new parts provided in the wire harness kit. Replace any other damaged or lost parts with the other parts provided in the wire harness kit.

Confirm all harness connectors are firmly connected, making sure you hear an audible “click” sound that indicates the connector is locked.

Take extra care when reattaching the fuel hoses and connectors/retainers. Be sure the O-rings are not deformed and the retainers are not stuck.

Be sure not to scratch any parts during reassembly.

Pour the fuel that was removed from the fuel tank back into the tank.

After installation is complete, complete a final inspection of the unit using the information below.

FINAL INSPECTION

After the wire harness has been replaced and the unit is reassembled, perform the following performance and appearance checks to ensure proper operation and condition.

1. Inspect the unit's overall appearance to ensure all body panels are correctly installed, and that there are no scratches on any surface.
2. Start the engine and inspect the unit for possible fuel leaks using your eyes and nose. If you see or smell fuel, turn the engine off immediately and inspect the fuel system carefully to find the source of the fuel leak and repair as necessary.
3. Turn the ignition switch the ON position and check the following functions:
 - Check the operation of all turn signals and ensure the front and rear signals for each side blink at the same time, in conjunction with the turn signal arrow on the gauge cluster/meter.
 - Check the operation of the horn.
 - Check the operation of the speedometer.
 - Ensure the engine runs, and unit rides and functions normally.
 - Ensure the E-Clutch system operates properly.

TECHLINE CONNECT - PHOTOGRAPH UPLOAD PROCEDURE

To find TechLine Connect, log in to *iN*, then follow the path below:

iN > Service > TechLine > TechLine > TechLine Connect

1. Complete all required fields shown.
2. Select *Photo/Video Request* in the Reason for Contact field.
3. Describe the type of damage found on the wire harness in the TechLine Customer Complaint field. Be sure to include if the damage is only on the sheathing or insulation, or if the copper wiring is visible.
4. Submit clear photos showing the damage to the wire harness. Attach photos by clicking on *Upload Attachment(s)*.

Please use the motorcycle's full VIN in the image file name(s) before uploading.

Example:

MLHRH1558R5000XXX-Image 1.jpg

Honda will contact you within one (1) business day and provide additional directions on how to proceed based on the information and photos that were submitted.

The screenshot shows the TechLine Connect form with the following fields and content:

- Required Fields (marked with a red dot):** DPTSID, SSN (Last 4 digits), E-Mail, New Case, Repair Order No., VIN, Mileage/Hours, Reasons for Contact, and Customer Complaint.
- Form Fields:**
 - DPTSID: [Empty text box]
 - SSN (Last 4 digits): [Empty text box]
 - E-Mail: [Empty text box]
 - Power House Dealer?:
 - New Case: YES (dropdown)
 - Repair Order No.: [Empty text box]
 - Repair Order Date: [Empty date picker]
 - VIN: [Empty text box]
 - Mileage/Hours: [Empty text box] MILES (dropdown)
 - DTC: [Empty text box]
 - Reasons for Contact: PHOTO/VIDEO REQUEST (dropdown, highlighted with a red box)
 - Attachments: YES (dropdown)
 - Customer Complaint: (Detailed explanation of issue including troubleshooting test results)
- Customer Complaint Text:** Visible damage was found on the 8P turn signal wire harness. The electrical tape sheathing has been worn through. The wire insulation itself is not damaged, and there are no visible copper strands. (This text is highlighted with a red box)
- Attachments Section:** Upload Attachment(s) (button, highlighted with a red box)
- Footer:** TechLine will respond to your request within one business day. Submit and Save buttons.

TEXT OF CUSTOMER LETTER



American Honda Motor Co., Inc.
4900 Marconi Dr.
Alpharetta, GA 30005-8847
Phone (866) 784-1870

NHTSA Recall Number: 25V-911
Honda Campaign Number: KT7
Service Bulletin Number: MTB 55408

IMPORTANT SAFETY RECALL

This notice applies to your vehicle: XXXXXXXXXXXXXXXXXXXX

February 2026

Dear FIRSTNAME LASTNAME,

This notice is sent to you in accordance with the National Traffic and Motor Vehicle Safety Act. Honda has decided that certain 2024-2025 model year CBR650R motorcycles fail to conform to Federal Motor Vehicle Safety Standard No. 108; "Lamps, reflective devices and associated equipment."

Why my vehicle is under recall: During normal use, vehicle vibration and friction can cause the turn signal switch wire harness insulation to wear against the left-side middle cowl bracket, exposing the copper core, causing an electrical short and blown fuse. If the fuse is blown, the motorcycle's turn signal, brake, and license plate lights, speedometer, and horn will not function, preventing the rider's ability to observe the speed and alert other drivers of the rider's actions/intended actions, increasing the risk of a crash or injury.

What Honda will do: Your Honda Powersports dealer will inspect and repair the harness, as necessary, for **FREE**. Honda estimates that the repair will take approximately 45 minutes to complete. However, your dealer can provide you with a better estimate of the overall time for this service visit, as it may be necessary to make your motorcycle available for a longer period of time.

What we need you to do:

Please call any authorized Honda Powersports dealer and schedule an appointment to have your motorcycle repaired, for **FREE**.

If you are not the only rider of this motorcycle, please advise all other riders and passengers of this important information.

- Check recall information for your motorcycle by accessing the Honda recall lookup tool at <https://powersports.honda.com/recalls> and entering your Vehicle Identification Number (VIN).
- If you have questions or concerns, we encourage you to:
 - visit <https://powersports.honda.com/recalls>; or
 - contact your local Honda Powersports dealer; or
 - send Customer Relations a message via <https://powersports.honda.com/contact-us>; or
 - call American Honda's Powersports Customer Relations at 1-866-784-1870 Monday through Friday, 8:30 a.m. to 4:30 p.m., Pacific Time.

If you paid out of pocket to have these specific recall repairs performed on your vehicle, you may be eligible for reimbursement; please contact American Honda's Powersports Customer Relations at 1-866-784-1870 to determine potential eligibility and for instructions on how to request reimbursement.

If you no longer own this vehicle or if any of the information is not correct, please complete and return the enclosed prepaid Information Change Card as soon as possible. If you are a lessor of this vehicle, federal regulations require you to forward this notice to your lessee within ten days.

If you believe that American Honda or the dealer has failed or is unable to remedy the defect in your vehicle, without charge and within a reasonable period of time (60 days from the date you first contact the dealer for a repair appointment), you may submit a complaint to the Administrator, National Highway Traffic Safety Administration (NHTSA), 1200 New Jersey Ave., SE, Washington, DC 20590. Alternatively, you may call the NHTSA toll-free Vehicle Safety Hotline at 1-888-327-4236 (TTY 1-800-424-9153) or go to <http://www.safercar.gov>.

We sincerely apologize for any inconvenience this recall may cause, but please be assured that your safety is our first concern.

Sincerely,

American Honda Motor Co., Inc.