



VOLUNTARY RECALL CAMPAIGN

Classification: WT25-001A	Reference: NTB26-001A	Date: February 12, 2026
------------------------------	--------------------------	----------------------------

VOLUNTARY SAFETY RECALL CAMPAIGN 2026 ROGUE; SPARE TIRE INSPECTION

This bulletin has been amended. See AMENDMENT HISTORY on the last page.
Please discard previous versions of this bulletin.

CAMPAIGN ID #: PD180
APPLIED VEHICLES: 2026 Rogue (T33)

**Check Service COMM or Dealer Business Systems (DBS)
National Service History to confirm campaign eligibility.**

INTRODUCTION

Nissan is conducting this voluntary safety recall campaign on certain specific model year 2026 Rogue vehicles to inspect, and if necessary, replace the spare tire. This service will be performed at no charge to the customer for parts or labor.

IDENTIFICATION NUMBER

Nissan has assigned identification number PD180 to this campaign. This number must appear on all communication and documentation of any nature dealing with this campaign.

DEALER RESPONSIBILITY

It is the dealer's responsibility to check Service COMM or Dealer Business Systems (DBS) National Service History for the campaign status on each vehicle falling within the range of this voluntary safety recall which for any reason enters the service department. This includes vehicles purchased from private parties or presented by transient (tourist) owners and vehicles in a dealer's inventory. **Federal law requires that new vehicles in dealer inventory which are the subject of a safety recall must be corrected prior to sale. Failure to do so can result in civil penalties by the National Highway Traffic Safety Administration.** While federal law applies only to new vehicles, Nissan strongly encourages dealers to correct any used vehicles in their inventory before they are retailed.

Bulletins are intended for use by qualified technicians, not 'do-it-yourselfers'. Qualified technicians are properly trained individuals who have the equipment, tools, safety instruction, and know-how to do a job properly and safely. **NOTE:** If you believe that a described condition may apply to a particular vehicle, DO NOT assume that it does. See your Nissan dealer to determine if this applies to your vehicle.

SERVICE PROCEDURE

1. Park the vehicle in a safe location with the automatic transmission in Park, the ignition OFF and the parking brake applied/ON.

2. Open the driver's door.

3. Locate the Tire and Loading Information Label located in the driver's door opening (Figure 1).

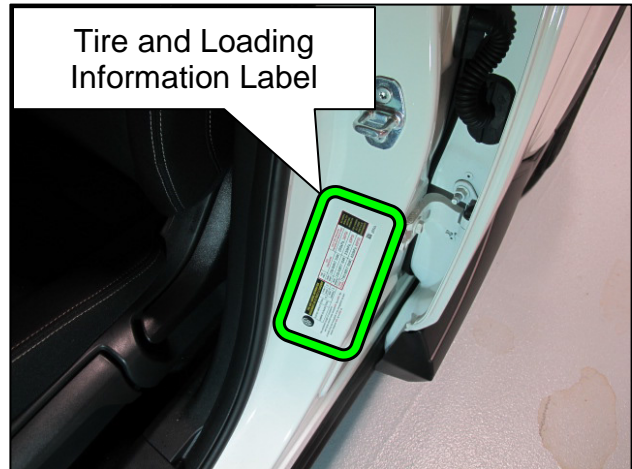

Figure 1

4. Write on the repair order the size of the spare tire as it is listed on the Tire and Loading Information Label (Figure 2).

HINT: The example in Figure 2 is an AWD vehicle, FWD vehicles will specify a different size tire.

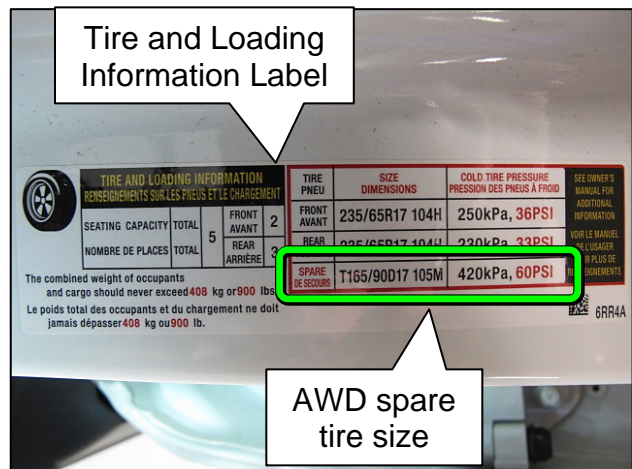

Figure 2

5. Close the driver's door.



Figure 3

6. Open the back door.



Figure 4

7. Remove the luggage board(s).
 - On SL and Platinum models with the adjustable luggage floor, release the locks before removing the rear (outer) luggage board.
 - On S and SV models with the single luggage board, disengage the retainer pins.
 - Remove the luggage floor carpet, if equipped.

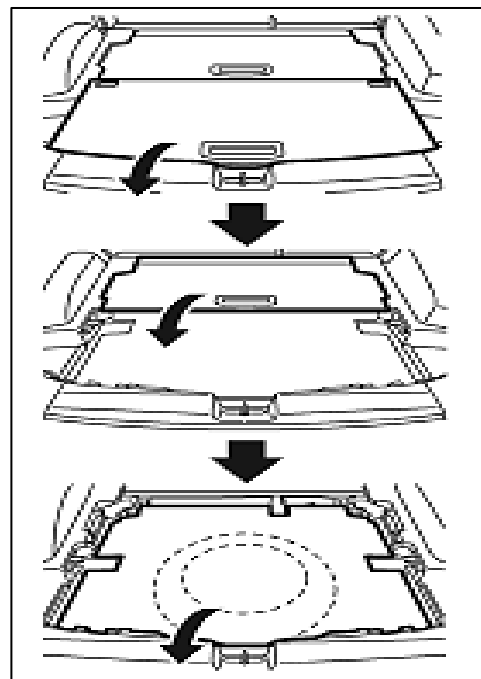

Figure 5

8. Locate the size on the spare tire and write it on the repair order (Figure 6).
- The tire size will be located on the sidewall of the tire, close to the steel rim.
 - The example in Figure 6 is "T165/90D17".

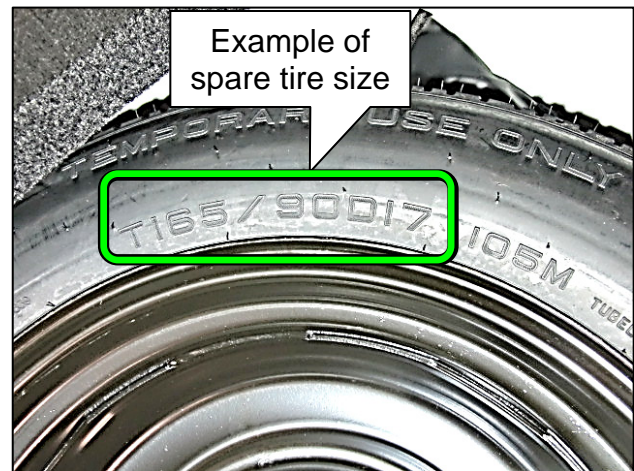

Figure 6

9. Compare the actual spare tire size to the spare tire size listed on the Tire and Loading Information Label. Do the tire sizes match?

YES: (GOOD) No further action is needed. Go to step 15 on page 7 to install the luggage boards/carpet if applicable.

NO: (NO GOOD) Skip to step 10 on page 5 to remove the spare tire and wheel assembly for tire replacement.

⚠ CAUTION

To prevent damage to the vehicle driveline, the spare tire size **MUST** match the spare tire size listed on the Tire and Loading Information Label.

10. Remove the spare tire and wheel assembly (Figure 7).
- Remove the spare tire retaining screw.
 - For SL and Platinum models, lift the subwoofer assembly upward from the spare tire and set it to the driver's (LH) side (Figure 8).

HINT: It is not necessary to unplug the subwoofer from the wiring harness.

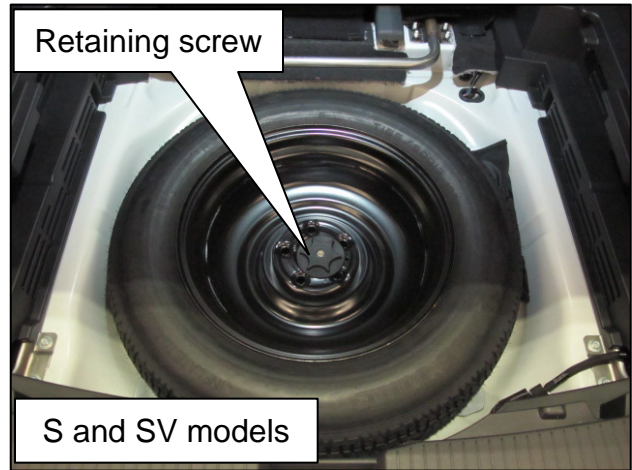

Figure 7

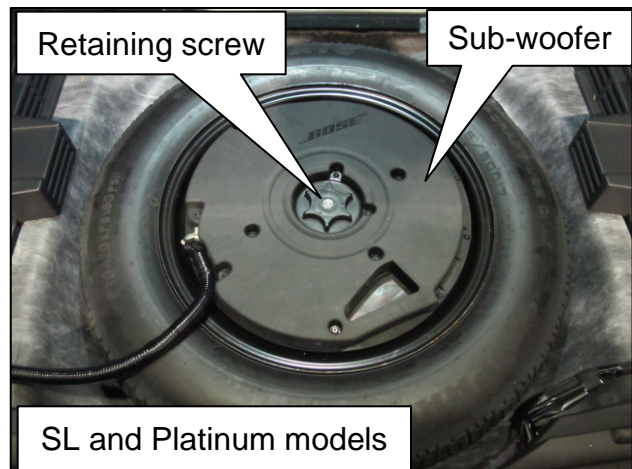

Figure 8

11. Replace **ONLY** the spare tire using normal tire replacement procedures. Do not replace the steel wheel as it will be reused.
 - There is no need to balance the wheel/tire assembly after the replacement spare tire has been installed.

CAUTION

To prevent damage to the vehicle driveline, the spare tire size **MUST** match the spare tire size listed on the Tire and Loading Information Label.

The correct spare tire sizes are listed by driveline below:

- **FWD: T155/80D17**
 - **AWD: T165/90D17**
12. Set the spare tire pressure to 420 kPa (**60 PSI**).
 13. Use a drill with a ½” drill bit to drill two (2) holes through the sidewall of the removed spare tire and dispose of the spare tire properly following all local, state, and federal regulations.

14. Install the spare tire and wheel assembly into the rear luggage area (Figure 9).

- For SL and Platinum models, install the subwoofer assembly into the spare tire.

HINT: Orient the arrow on the subwoofer to face toward the front of the vehicle. This properly aligns the harness so it clears the luggage board support blocks.

- On all models, install the spare tire retaining screw.

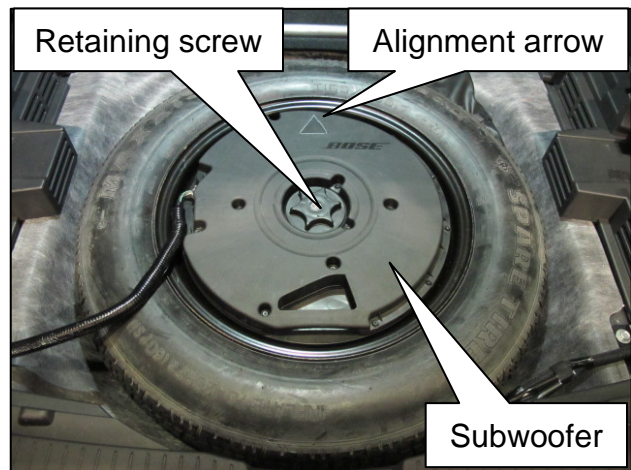

Figure 9

15. Install the luggage board(s) and luggage floor carpet if equipped.



Figure 10

16. Close the back door.



Figure 11

PARTS INFORMATION

DESCRIPTION	PART NUMBER	QUANTITY
Replacement Spare Tire (FWD) Maxxis M9300 T155/80D17 101M	TBILLS2611 (1)	1 As needed
Replacement Spare Tire (AWD) Falken FK-090 BW T165/90D17 105M	TBILLS2580 (1) (2)	1 As needed
Replacement Spare Tire (AWD) Maxxis M9300 T165/90D17 105M	TBILLS2612 (1)	Optional (AWD)

- Order this item through the Nissan Maintenance Advantage program: Phone 877-NIS-NMA1 (877-647-6621). Website order via link on the dealer portal; www.NNAnet.com and click on the "Maintenance Advantage-Tire/Battery/Chemical" link.
- Order Falken TBILLS2580 FIRST for AWD applications. If unavailable, order Maxxis TBILLS2612.

CLAIMS INFORMATION

Submit a "CM" line claim using the following claims coding:

CAMPAIGN ("CM") ID	DESCRIPTION	OP CODE	FRT
PD180	Inspect Spare Tire (GOOD CONDITION)	PD1800	0.2
	Inspect Spare Tire and Replace the Spare Tire	PD1801	0.4

EXPENSE CODE

EXPENSE CODE	DESCRIPTION	MAX AMOUNT
831 *	Tire Replacement, Shipping Fees and Disposal Fees – TBILLS2580 (AWD) Falken	\$205.40
832 *	Tire Replacement, Shipping Fees and Disposal Fees – TBILLS2611 (FWD) Maxxis	\$302.78
833 *	Tire Replacement, Shipping Fees and Disposal Fees – TBILLS2612 (AWD) Maxxis	\$306.28

*Use this **EXPENSE CODE** for tire(s) reimbursement. DO NOT claim the Dealer Tire part number on the claim. This expense code should only be used when a tire(s) is replaced.

NOTE: MAX AMOUNT includes local and state tax as well as disposal fees.

AMENDMENT HISTORY

PUBLISHED DATE	REFERENCE	DESCRIPTION
January 5, 2026	NTB26-001	Original bulletin published
February 12, 2026	NTB26-001A	PARTS INFORMATION and EXPENSE CODE revised