



Technical Service Bulletin

GROUP	NUMBER
RECALL	26-01-005G
DATE	MODEL(S)
JANUARY 2026	G90 (RS4)

SUBJECT: FALSE DETECTION OF VEHICLE WITH HIGHWAY DRIVE ASSIST ENABLED (RECALL 030G)

★ IMPORTANT

Vehicle repairs related to safety recalls are critically important and must be performed properly in accordance with TSB procedures. Review this bulletin in its entirety prior to beginning any repair work.

As required by federal law, retailers must not deliver new vehicles for sale or for lease to guests until all open recalls have been performed. Retailers must also perform all open recalls on used vehicles, demo, and rental vehicles prior to placing them into guest use and whenever an affected vehicle is in the shop for any maintenance or repair.

Access the "Vehicle Information" screen via WebDCS to identify open recalls.

Description: Certain G90 (RS4) vehicles painted in Seville Silver (SSS) and equipped with Highway Drive Assist (HDA)—an advanced driver assistance system that enables semi-autonomous driving on limited-access highways under continuous driver supervision—may, under specific conditions, falsely detect another vehicle entering the lane of travel and apply the brakes without warning. This may occur when HDA is enabled at speeds below approximately 12 mph or when HDA is enabled in conjunction with the Lane Change Assist (LCA) feature, which is activated by the driver signaling a lane change. Sudden, unintended braking can increase the risk of a crash. This bulletin provides instructions to replace the front bumper beam assembly with a revised part to address this condition.

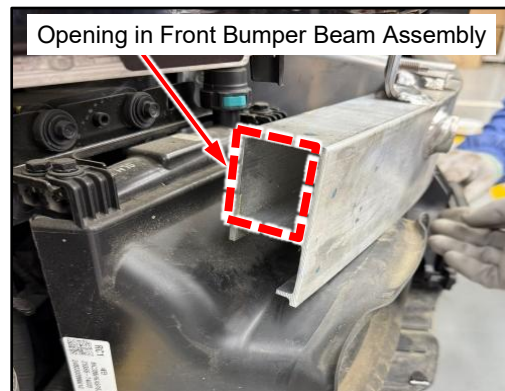



Applicable Vehicles:

Model Year	Model	Paint Color	Production Dates
2023 – 2026	G90 (RS4)	Seville Silver (SSS)	04/21/2022 – 11/01/2025



Circulate To: General Manager, Service Manager, Parts Manager, Warranty Manager, Service Advisors, Technicians, Body Shop Manager, Fleet Repair

Parts Information:

Model	Part Name	Part Number	Figure	Remarks
G90 (RS4)	Beam Complete -FR Bumper	64900-T4100QQH		Qty: 1
	Retainer-Cowl Top Cover MTG	86155-2H100		Replace if damaged
	Clip	14206-08250-B		

NOTE: Dealers will be reimbursed via sublet as noted for any clips, regardless of replacement or not.

SST Information:

Tool Name	Tool Number	Figure	Remarks	Ordering Information
Laser	09964-C1200		Check and adjustment of front radar installation angle	Website: https://genesisessentialtools.com Email: Genesistools@snapon.com Phone: 1-855-763-6630 Hours: 7 AM – 7 PM CST
Tripod	09964-C1300			
Reflector	09964-C1100			
Reflector Adapter	0K964-J5100			

Warranty Information:

Model	Op. Code	Operation	Op. Time	Causal Part	Nature Code	Cause Code
G90 (RS4)	51D323R0	Front Bumper Beam Assembly Replacement and Front Radar Calibration	1.2 M/H	64900-T4100	I14	ZZ1

NOTE 1: Submit claim on Claim Entry Screen as “Campaign” type.

NOTE 2: If any part(s) not subject to this TSB are found in need of replacement while performing the repair procedure, and the affected part(s) are still under warranty, the retailer may submit a separate claim using the same repair order. If the part(s) not subject to this TSB are out of warranty coverage, the retailer has the option to submit a PA Request for goodwill consideration on a case-by-case basis.

NOTE 3: This TSB includes repair validation photos. Op times include VIN, mileage, and repair validation photo(s) as outlined in the Digital Documentation Policy.

NOTE 4: The incident parts are subject to callback through the normal Warranty Technical Center (WTC) parts return process. **Claim is subject to debit if the part is not returned.**

Service Procedure:

DIGITAL DOCUMENTATION



This TSB includes repair validation photos. Refer to the latest Warranty Digital Documentation Policy for requirements.

CAUTION

Wear gloves to prevent hand injuries.

NOTICE

- Applying the recommended torque to all fasteners is essential to reduce potential issues from occurring after the service procedure.
- Use a plastic trim removal tool to avoid damaging trim and panels during the procedure.
- Do **NOT** bend or scratch trim and panels.

1. Disconnect the negative (-) battery terminal (A) by referring to the shop manual:

- **Engine Electrical System > Charging System > Battery > Removal**

Tightening Torque:

lb-ft	6.5
lb-in	78
N.m	8.8

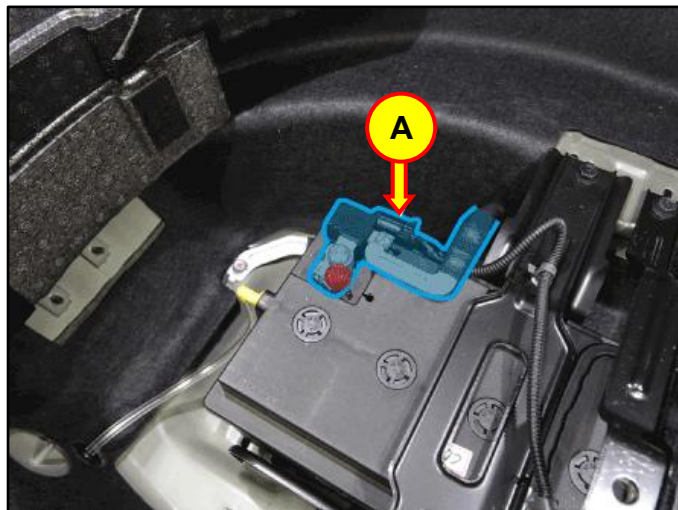

2. Remove the front bumper assembly (B) by referring to the shop manual:

- **Body (Interior / Exterior / Electrical) > Front & Rear Bumper > Front Bumper Assembly > Removal and Installation**

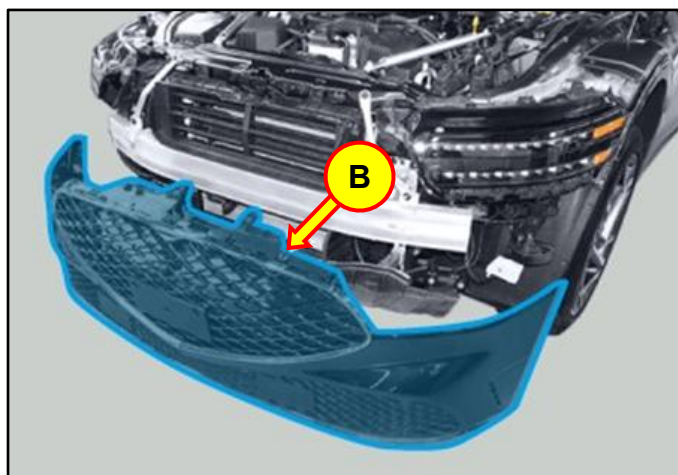

3. If equipped, remove the active hood sensor and unit assembly (C) by referring to the shop manual:

- **Restraint > Active Hood Lift System > Active Hood Sensor & Unit Assembly > Removal and Installation**

Tightening Torque:

lb-ft	8.0
lb-in	91
N.m	10.3

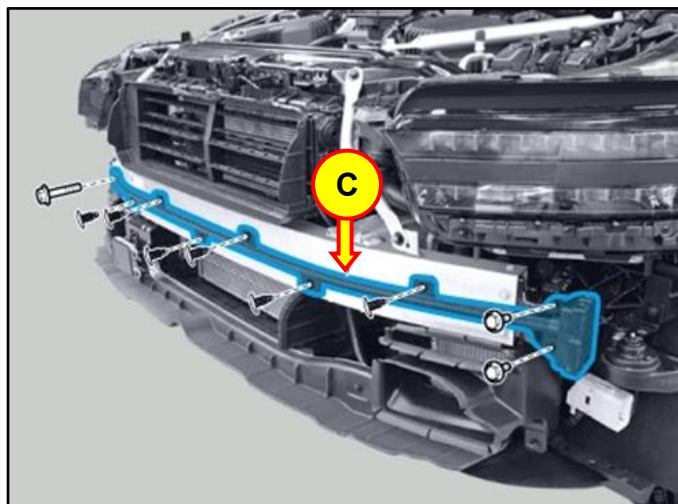

4. Disconnect the front radar connector (D).

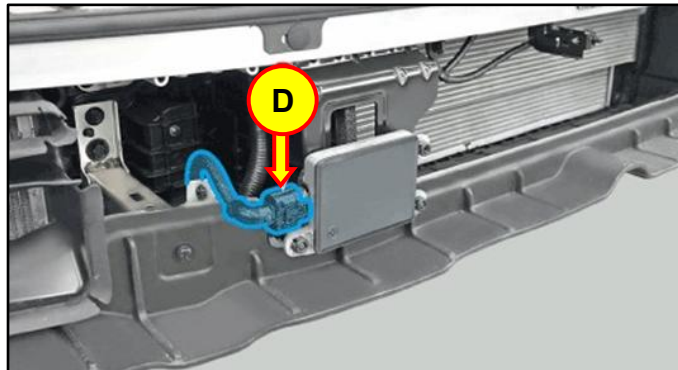

5. Disconnect the ambient temperature sensor connector (E).

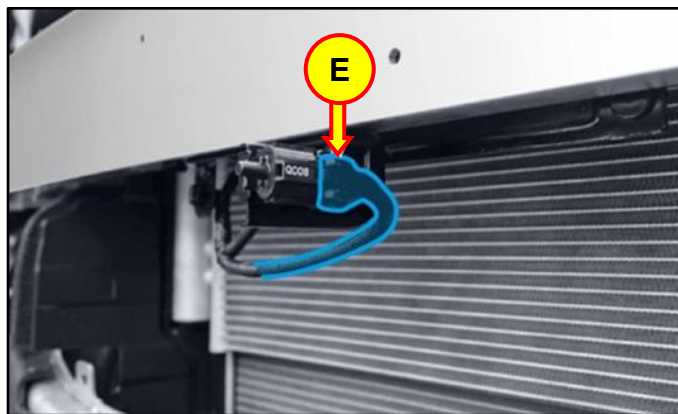

6. Disconnect the smart key antenna connector (F).

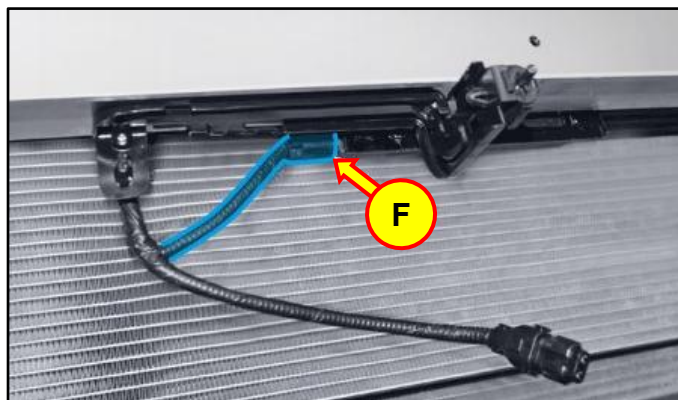

7. Remove the engine room cross bars (G) after removing the bolts and nuts.

Tightening Torque:

Nuts:

lb-ft	26
N.m	36

Bolts:

lb-ft	18
N.m	24

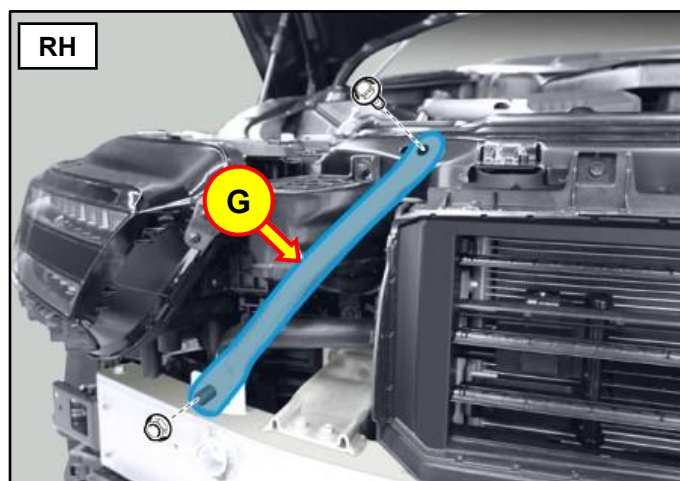
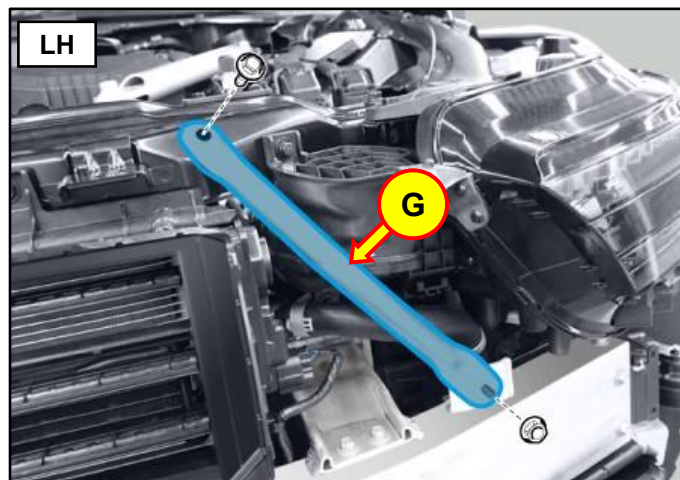

8. Remove the front bumper beam assembly (H), after removing the bolts and nuts.

Tightening Torque:

Nuts:

lb-ft	5.4
lb-in	65
N.m	7.4

Bolts:

lb-ft	18
N.m	24

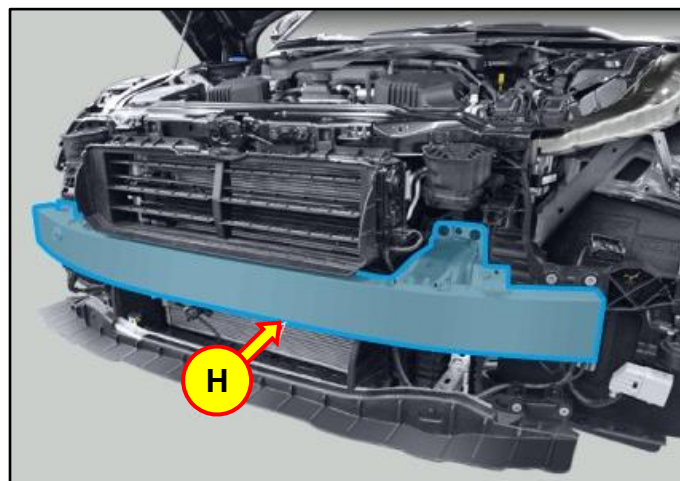

9. Transfer the front radar (I), ambient temperature sensor (J), and smart key antenna bracket (K) onto the new front bumper beam assembly.

Tightening Torque:

lb-ft	7.3
lb-in	87
N.m	9.8

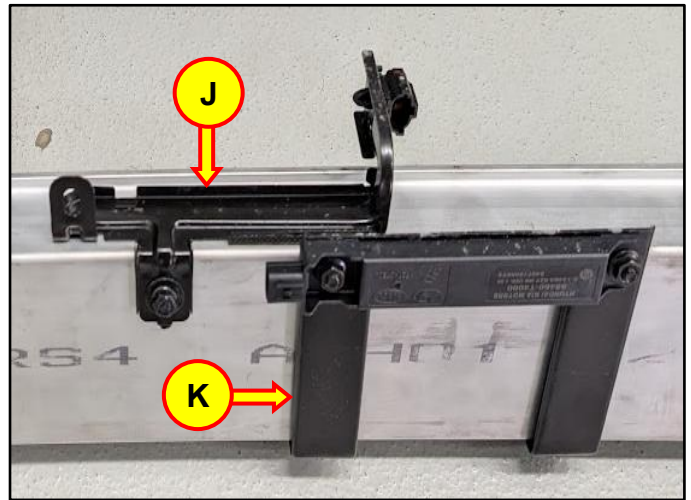
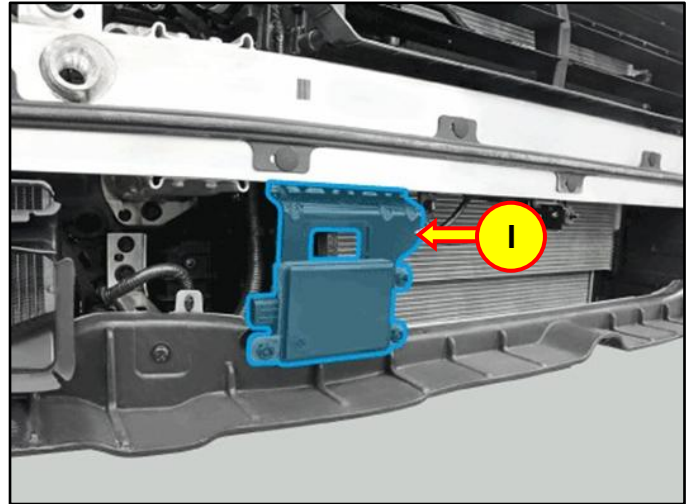

10. Install the new front bumper beam assembly (H).

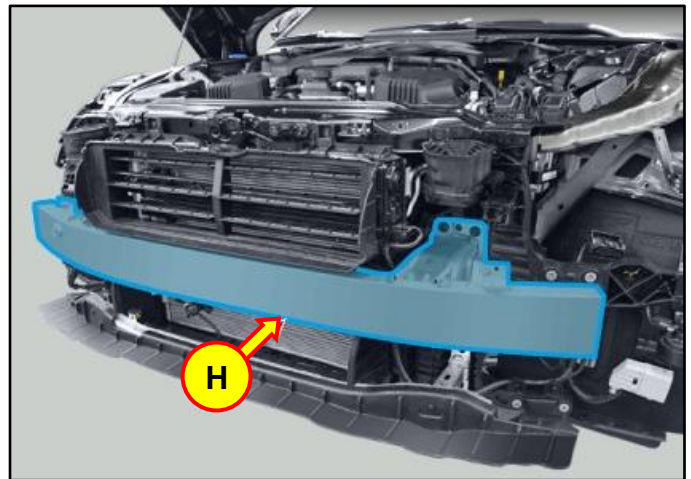

11.

**DIGITAL
DOCUMENTATION**

Using the STUI camera function, take a photo of the new front bumper beam assembly showing the updated design change of the end caps.

Upload the photo to STUI.

NOTE: If the STUI camera function is **NOT** used, write the last 6 digits of the VIN and date of repair on a piece of paper to include in the photo.



12. Reinstall all parts in the reverse order of the removal process.

NOTICE

Confirm all connectors are properly engaged.

Replace any damaged clips or retainers.

13. Inspect and adjust the front radar installation angle by referring to the shop manual:

- **Advanced Driver Assistance System (ADAS) > Advanced Driver Assistance System Driving > Front Radar > Adjustment**

14. The service procedure is now complete.