

**SAFETY RECALL**  
 NORTH AMERICA  
**Curtain Airbag Inflator**



Reference: C7C / NHTSA 25V-824

FCA US LLC



**RAM** Remedy available for

- 2019 (DS) Ram 1500 Pickup
- 2019 (DJ) Ram 2500 Pickup
- 2019 (D2) Ram 3500 Pickup

Template Version 1.0

Revision	Edition	Detail
2	February 2026	Revised Parts Information and Parts Disposal sections.

**SYMPTOM DESCRIPTION**

The Curtain Airbag (CAB) inflator on about 887 of the above vehicles may rupture result in compressed gas rapidly escaping from the inflator and material potentially being propelled into the vehicle. Material being propelled into an occupied vehicle may cause injury.

**SCOPE**

This recall applies only to the above vehicles equipped with a Crew Cab or Mega Cab configuration.

NOTE: Some vehicles above may have been identified as not involved in this recall and therefore have been excluded from this recall.

**IMPORTANT:**

- Some of the involved vehicles may be in dealer new vehicle inventory. Federal law requires you to complete this recall service on these vehicles before retail delivery. Violation of this requirement by a dealer could result in a civil penalty of up to \$27,874 per vehicle.
  - Some of the involved vehicles may be in dealer used vehicle inventory. Dealers should complete this recall service on these vehicles before retail delivery.
  - Dealers should also perform this recall on vehicles in for service.
- Involved vehicles can be determined by using the VIP inquiry process.

**REPAIR TO BE PERFORMED**

Replace Left Side (Driver Side) CAB.

**ALTERNATE TRANSPORTATION**

Dealers should proactively minimize customer inconvenience while the recall repair is being performed. Reference the Goodwill Alternate Transportation Guidelines warranty bulletin link within Recall Central on DealerCONNECT for options to support the customer while their vehicle is in service.

**COMPLETION REPORTING / REIMBURSEMENT**

Claims for vehicles that have been serviced must be submitted on the DealerCONNECT Claim Entry Screen located on the Service tab. Claims paid will be used by FCA to record recall service completions and provide dealer payments.

Use the following labor operation numbers and time allowances:

Repair Labor Description	Number	Hrs
Replace Left Side CAB (Crew Cab)	23-C7-C1-82	1.3
Replace Left Side CAB (Mega Cab)	23-C7-C1-83	1.6

**Add the cost of the recall parts plus applicable dealer allowance to your claim.**

**NOTE: See the Warranty Administration Manual, Recall Claim Processing Section, for complete recall claim processing instructions.**

For Mobile Service Reimbursement, dealer to include standard dealer entry and mark-up for parts, standard dealer entry and labor rate for service, as well as the special services code for mobile allowance. The special services LOP will only be paid once per VIN and may NOT be used in coordination with any Alternate Transportation claims.

For additional details, reference the Mobile Service Warranty Bulletin - for convenience, a copy has been linked within Recall Central on DealerCONNECT.

**PARTS INFORMATION**

**NOTE: Do not destroy the replacement inflator packaging, it will be used to return the original inflator for disposal.**

**Crew Cab vehicles ONLY.**

Part No.	Qty.	Part Name
06036773AA	2	Bolt - Seatbelt Turning Loop
CSSLY552AA	1	CAB Left Side

**Mega Cab vehicles ONLY.**

Part No.	Qty.	Part Name
06036773AA	2	Bolt - Seatbelt Turning Loop
06036690AA	2	Bolt - Seatbelt Turning Loop
CSSLY556AA	1	CAB Left Side

**PARTS DISPOSAL (OPTIONAL)**

Original Mopar inflator packaging must be used for the following disposal procedure.

**International (including Mexico), Hawaii, Alaska, Puerto Rico, and US Virgin Islands: No part return available. Destroy the original inflator using locally approved methods.**

**Airbag Disposal Return Process**

**\*\*Only Airbag part numbers included in this Recall Campaign are eligible\*\***

Upon Accumulating 52 boxes per pallet (shrink-wrapped or strapped)

(Multiple Pallets are acceptable)

**Please Email RXO to Schedule LTL Pickup:**

- **US Domestic Collections -**  
**scfieldaction.14305@rxo.com**
- **Canada International Collections -**  
**sctakatarestraints\_international@rxo.com**

No response after 48 - 72 hours call the escalation number, (210) 317-6436 for further assistance.

Items to have available in email request:

- 1) Dealer Code
- 2) Quantity Pallets/Overpacks with # of boxes on each pallet
- 3) Dealer E-mail Address for Shipping Documentation to be received
- 4) Liftgate Service - Yes or No

**SPECIAL TOOLS**

Number	Description
NPN	wiTECH MicroPod II / MDP
NPN	Laptop Computer
NPN	wiTECH Software
C-4755	Trim Stick or equivalent

**DEALER NOTIFICATION**

To view this notification on DealerCONNECT, select "Global Recall System" on the Service tab, then click on the description of this notification.

**OWNER NOTIFICATION / SERVICE SCHEDULING**

All involved vehicle owners known to FCA are being notified of the service requirement by first class mail. They are requested to schedule appointments for this service with their dealers.

**VEHICLE LISTS, GLOBAL RECALL SYSTEM, VIP AND DEALER FOLLOW UP**

All involved vehicles have been entered into the DealerCONNECT Global Recall System (GRS) and Vehicle Information Plus (VIP) for dealer inquiry as needed.

GRS provides involved dealers with an updated VIN list of their incomplete vehicles. The owner's name, address and phone number are listed if known. Completed vehicles are removed from GRS within several days of repair claim submission.

To use this system, click on the "Service" tab and then click on "Global Recall System." Your dealer's VIN list for each recall displayed can be sorted by: those vehicles that were unsold at recall launch, those with a phone number, city, zip code, or VIN sequence.

**Dealers must perform this repair on all unsold vehicles before retail delivery.** Dealers should also use the VIN list to follow up with all owners to schedule appointments for this repair.

*Recall VIN lists may contain confidential, restricted owner name and address information that was obtained from the Department of Motor Vehicles of various states. Use of this information is permitted for this recall only and is strictly prohibited from all other use.*

**SAFETY RECALL**  
NORTH AMERICA  
**Curtain Airbag Inflator**



Reference: C7C / NHTSA 25V-824

FCA US LLC

---

**ADDITIONAL INFORMATION**

If you have any questions or need assistance in completing this action, please contact your Service and Parts District Manager.

Customer Services / Field Operations  
FCA US LLC.

---

Section A. Crew Cab **Page 4**

Section B Mega Cag **Page 18**

## SERVICE PROCEDURE

### A. Crew Cab

1. Using a small flat-bladed tool, carefully open the two fastener covers (3) located in the A-pillar trim panel (2) (Figure 1).

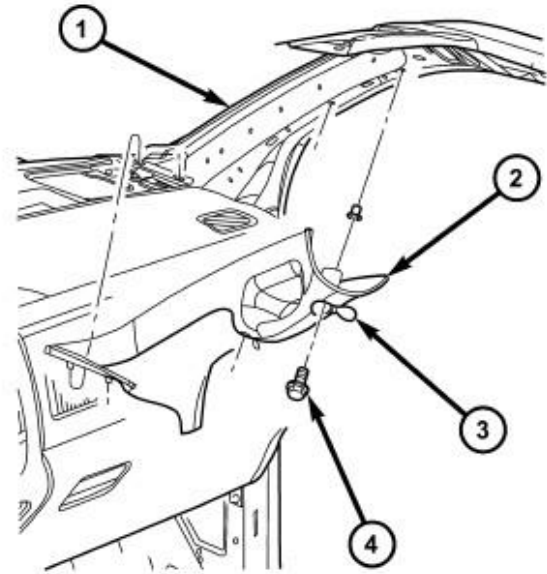

80d407a9

**Figure 1 – A-Pillar**

3. Separate the visor from the support (1) then remove the screw and remove the visor support (Figure 2).

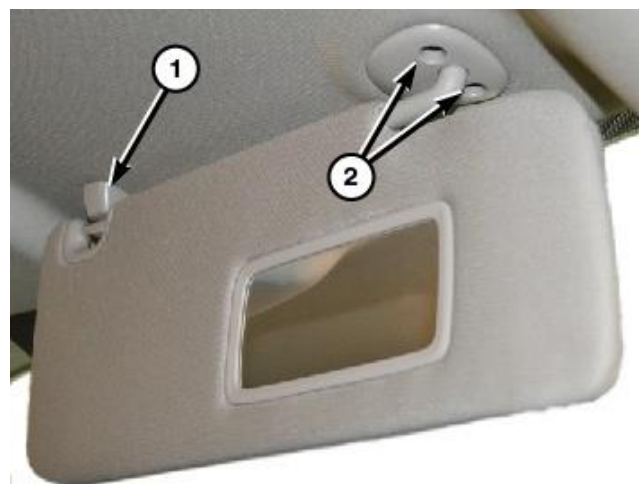

**Figure 2 – Visors**

- Using a small flat bladed tool or equivalent, release the retaining tabs (1) and separate the visor from the headliner (Figure 3).

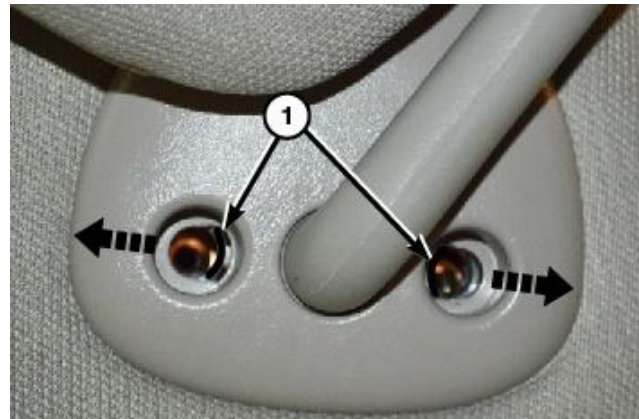
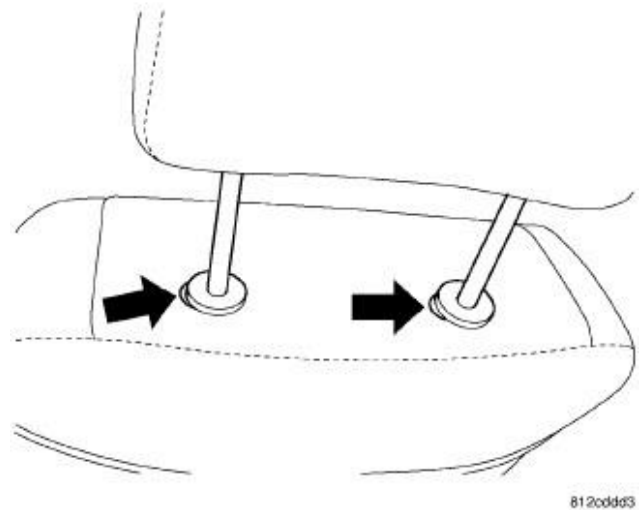

**Figure 3 – Visors**

- Disconnect the visor electrical connector if equipped.

**NOTE:** In some cases, the wire harness for the visor vanity mirror may be glued to the top side of the headliner and may be a little difficult to release.

- Push in the buttons on front seat headrest sleeves then pull the headrest up and remove (Figure 4).



8120dd63

**Figure 4 – Head Rest**

- Position the front seats to the full forward position with the seat backs fully forward.

9. Disconnect and isolate the negative battery cable. If equipped with an Intelligent Battery Sensor (IBS), disconnect the IBS connector first before disconnecting the negative battery cable. Wait two minutes for the system capacitor to discharge before further service.

**WARNING:** To avoid serious or fatal injury on vehicles equipped with airbags, disable the Supplemental Restraint System (SRS) before attempting any steering wheel, steering column, airbag, seat belt tensioner, impact sensor or instrument panel component diagnosis or service. Disconnect and isolate the battery negative (ground) cable, then wait two minutes for the system capacitor to discharge before performing further diagnosis or service. This is the only sure way to disable the SRS. Failure to take the proper precautions could result in accidental airbag deployment.

**WARNING:** To avoid serious or fatal injury when removing a deployed airbag, rubber gloves, eye protection, and a long-sleeved shirt should be worn. There may be deposits on the airbag unit and other interior surfaces. In large doses, these deposits may cause irritation to the skin and eyes.

**WARNING:** To avoid serious or fatal injury, use extreme care to prevent any foreign material from entering the side curtain airbag, or becoming entrapped between the side curtain airbag cushion and the headliner. Failure to observe this warning could result in occupant injuries upon airbag deployment.

**NOTE:** The following procedure is for replacement of an ineffective or damaged side Curtain Airbag (CAB). If the airbag is ineffective or damaged, but not deployed, review local ordinances regarding recommended procedures for handling and disposal of Non-Deployed Supplemental Restraints.

**NOTE:** If a side curtain airbag is being removed, but has not been deployed, the headliner does not need to be removed from the passenger compartment. Lowering the headliner and resting it on the seat backs will allow enough clearance to remove the side curtain airbag from the vehicle.

10. Release the front and rear door sill scuff plates on either side of the B pillar lower trim panel to allow for removal of the B-pillar lower trim panel (Figure 5).



**Front Door Sill**



**Rear Door Sill**

**Figure 5 – Door Sill Scuff Plates**

**SAFETY RECALL**  
NORTH AMERICA  
**Curtain Airbag Inflator**



Reference: C7C / NHTSA 25V-824

FCA US LLC

11. Release the retaining clips and remove the B-pillar lower trim panel to allow for removal of the B-pillar upper trim panel (Figure 6).

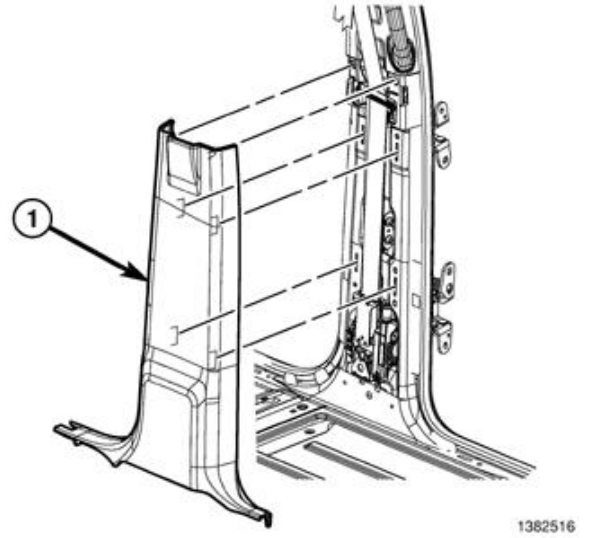

**Figure 6 – B-Pillar Lower Trim Panel**

12. On the B-pillar, separate the seatbelt turning loop cover then remove the turning loop bolt (Figure 7).

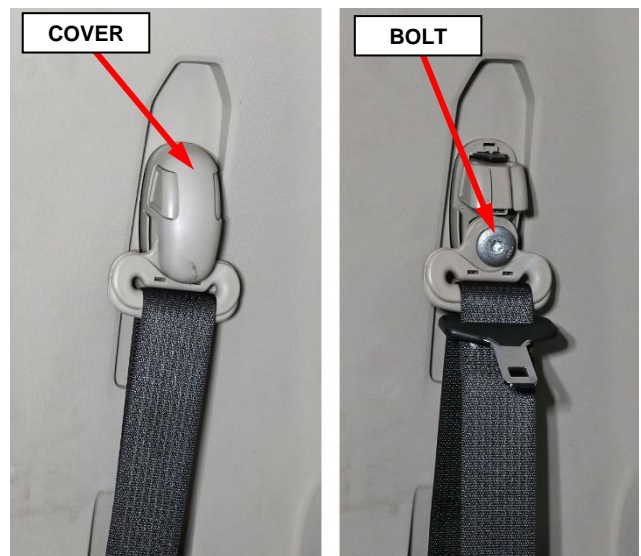

**Figure 7 – Seat Belt Turning Loop**

13. On the B-pillar, use a small flat-bladed tool to carefully open the two fastener covers (2) located on the grab handle (Figure 8).
14. Remove the two bolts (3) that secure the grab handle to the B pillar (Figure 8).
15. Using a trim stick C-4755 or equivalent, release the retaining clips that secure the B pillar upper trim panel (1) then position the trim panel out of the way. It is not necessary to remove the seat belt from the trim panel (Figure 8).

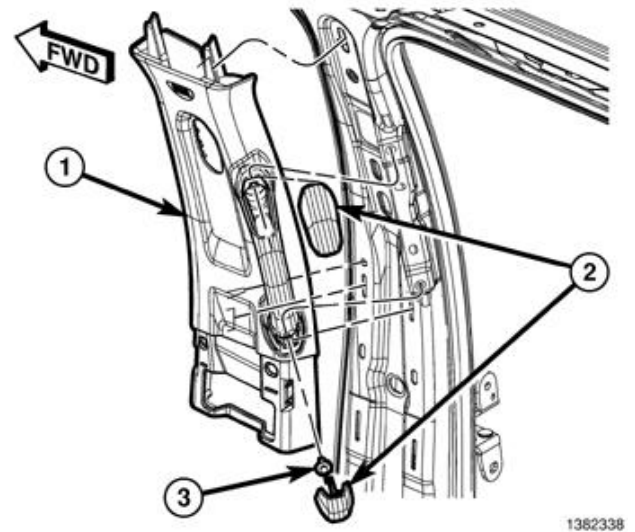

**Figure 8 – B-Pillar Upper Trim Panel**

16. Using a small flat bladed tool, open the coat hook screw cover (2) then remove the screw and coat hook (Figure 9).

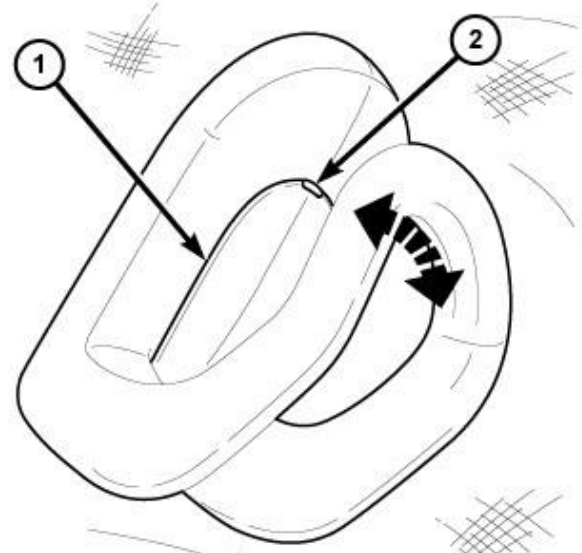

**Figure 9 – Coat Hook**

**NOTE: Do not drop the screw inside the C-pillar, a magnetic screwdriver may be helpful.**

17. Using a trim stick or equivalent, release the C-pillar airbag applique then remove the screw that secures the upper trim panel (Figure 10).

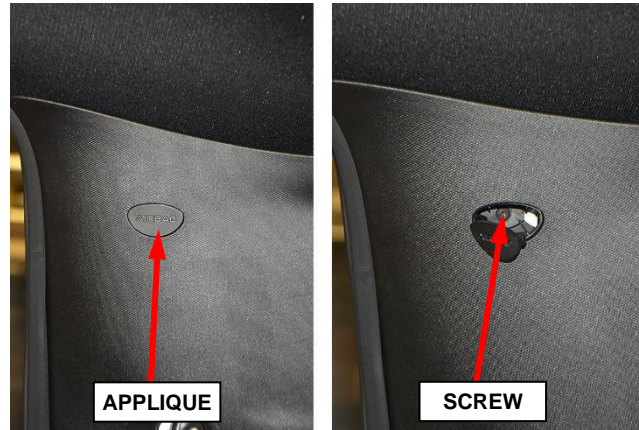

**Figure 10 – C-Pillar Upper Trim Panel**

18. Release the retaining clips and tilt the top of the C-pillar upper trim panel inward (Figure 11).



**Figure 11 – C-Pillar Trim Panels**

19. If equipped with DVD monitor, remove the screws (2) and separate the monitor (1) from the roof (Figure 12).

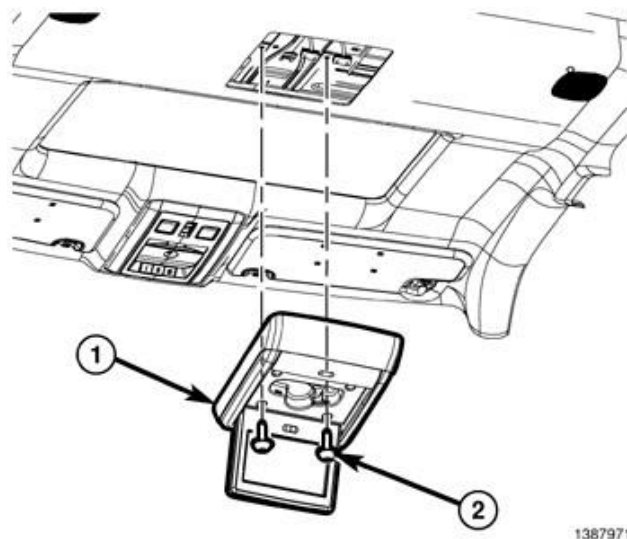

**Figure 12 – Rear Seat DVD Monitor**

20. If equipped with DVD monitor, disconnect the electrical connectors (1) (Figure 13).

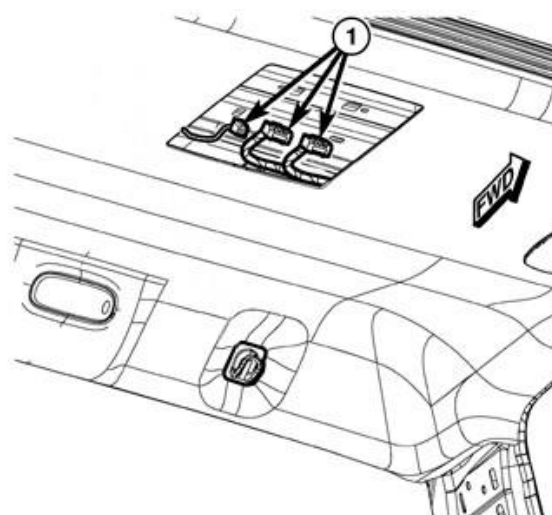

**Figure 13 – DVD Monitor Electrical Connectors**

21. As necessary, release the headliner wiring harness clips (3) from the A-pillar to allow enough wiring harness slack for lowering the headliner (Figure 14).

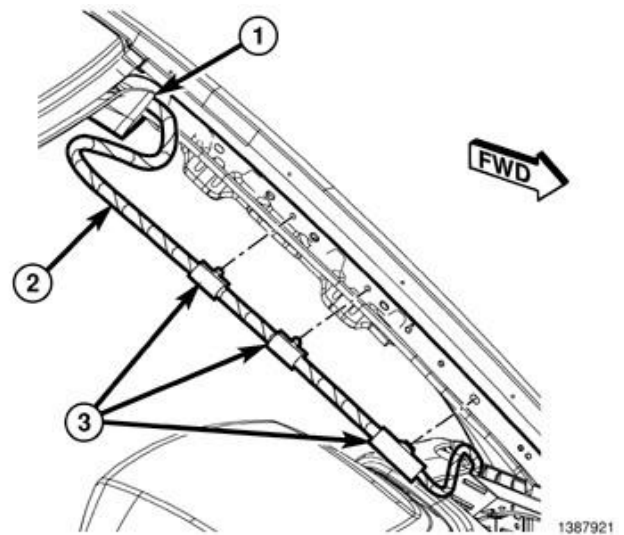

**Figure 14 – Headliner Harness**

22. Release the door seals from the door openings to allow for lowering of the headliner.
23. Tilt the rear view mirror up to allow clearance for lowering the headliner (Figure 15).

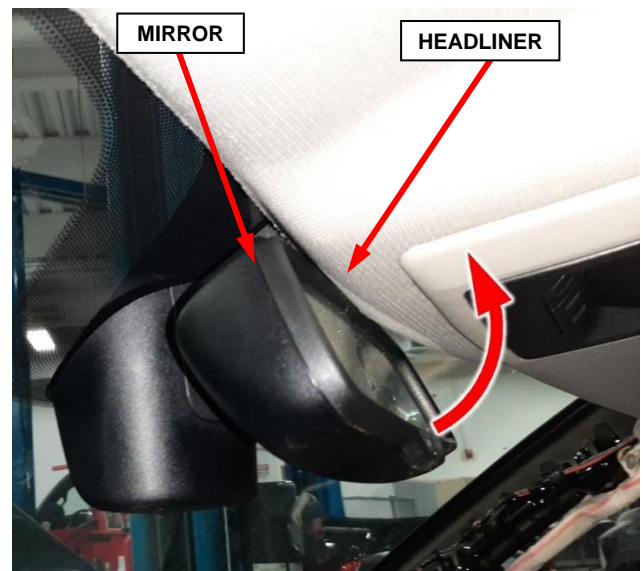

**Figure 15 – Rearview Mirror**

**SAFETY RECALL**  
NORTH AMERICA  
**Curtain Airbag Inflator**



Reference: C7C / NHTSA 25V-824

FCA US LLC

24. Carefully tilt the front of the headliner (2) down to clear the rear view mirror then slide the headliner forward to clear the C pillar trim while disconnecting any wiring harness electrical connectors (1) as necessary to allow enough wiring harness slack to lower the headliner (Figure 16).

25. lower the headliner (2) allowing it to rest on the seat backs and instrument panel (Figure 16).

**NOTE: It will not be necessary to remove the headliner from the vehicle.**

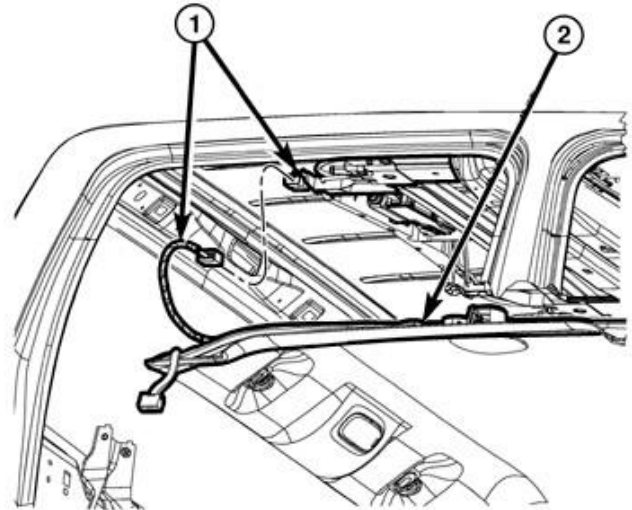

**Figure 16 – Headliner Harness**

26. Obtain the appropriate replacement CAB for the vehicle based on its VIN.

27. The body wire harness connector (5) is secured by integral latches to the connector receptacle on the inflator (4). Pinch both latches firmly, then pull the connector straight out from the airbag inflator to disconnect it from the connector receptacle (Figure 17).
28. Remove the six bolts (8) that secure the side curtain airbag (6) to the inner roof rail and A-pillar (Figure 17).
29. Disengage the push-in retainer (9) that secures the side curtain airbag tether to the inner A-pillar (1) and the two push-in retainers (7) that secure the side curtain airbag to the inner roof rail (Figure 17).
30. Slide the inflator rearward far enough to disengage the T-tab at the front of the inflator bracket from the keyed T-slot in the inner roof rail over the rear door opening (Figure 18).
31. Remove the CAB (6) from the vehicle as a unit and **DISCARD** following local ordinances and recommended procedures for handling and disposal of Non-Deployed Supplemental Restraints (Figure 17). Provided packaging is not authorized for the transport of the recalled CAB Module. Parts will need to be either deployed on-site or transported in alternative approved containers.

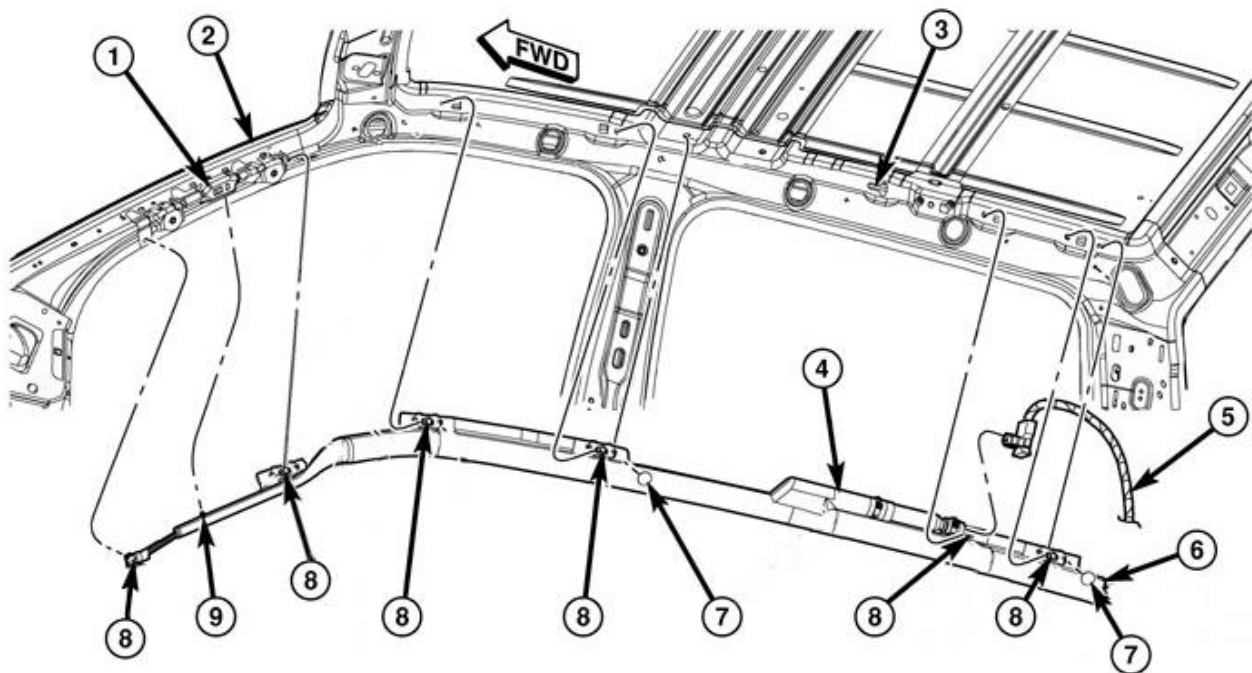

**Figure 17 – Side Curtain Airbag**

32. Check to be certain that the spring nuts are properly installed in the inner roof rail and that they are in good condition.
33. Position the **NEW** CAB (6) into the vehicle as a unit (Figure 17).

34. Insert the T-tab at the front of the inflator bracket into the keyed T-slot in the inner roof rail over the rear door opening and slide the inflator forward to engage it (Figure 18).

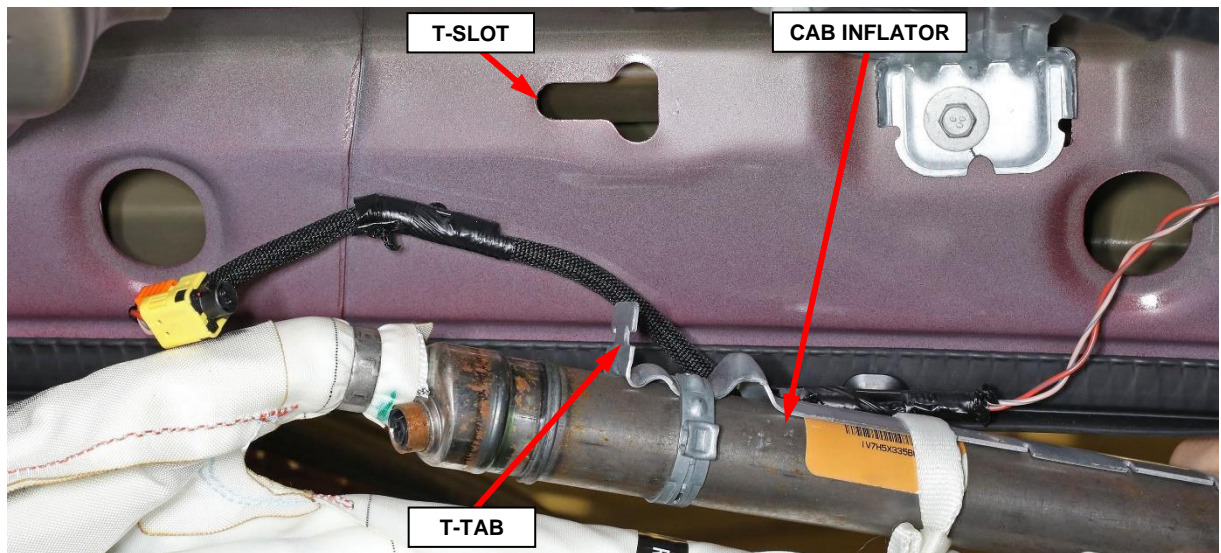

**Figure 18 – CAB Inflator T-Tab and Inner Roof Rail T-Slot**

35. Engage the two push-in retainers (7) that secure the side curtain airbag to the inner roof rail and ensure the tether is not twisted then engage the plastic push-in retainer (9) that secures the side curtain airbag front tether to the assist handle bracket on the inner A-pillar (1) (Figure 17).
36. Working from rear to front, install and tighten the six bolts (8) that secure the side curtain airbag (6) to the inner roof rail and A-pillar and ensure the tether is not twisted. Tighten the bolts to 7 N·m (62 in. lbs.) (Figure 17).
37. Connect the body wire harness connector (5) for the side curtain airbag to the connector receptacle of the inflator (4). Be certain that each connector is fully engaged in its receptacle by listening carefully for a distinct, audible click as the connector latches snap into place (Figure 17).

**CAUTION: Hands should be clean or clean cloth gloves used when handling the headliner to avoid damage to the headliner.**

38. Raise the headliner into proper vehicle position and connect any electrical connectors previously disconnected from the headliner (Figure 16).

**CAUTION: Be certain to avoid any wiring or drain tube interference.**

39. Tilt the rear view mirror down to allow it to support the headliner (Figure 15).
40. Reattach any headliner wiring harness clips (3) removed from the A-pillar to allow slack while lowering headliner (Figure 14).
41. If equipped with DVD monitor, connect the DVD monitor electrical connectors (1) (Figure 13). Position the DVD monitor to the roof then install and tighten the screws (2) (Figure 12).

42. Position the upper trim panel to the C-pillar then engage the retaining clips (Figure 11).
43. Install and tighten the screw that secures the C-pillar upper trim panel. Then install the airbag applique (Figure 10).
44. Position the coat hooks (5) onto the headliner and install the screws tightening securely into the mounting clips then close the screw cap fully (Figure 9).
45. Install the B-pillar upper trim panel (1) and engage the retaining clips fully (Figure 8).
46. Install the grab handle bolts (3) and tighten to 5 N·m (44 in. lbs.). Close the fastener covers (2) (Figure 8).
47. Remove and **DISCARD** the bolt retainer and the bolt from the seat belt turning loop, save the spacer washer for reuse (Figure 19).
48. Using a **NEW** bolt and reusing the spacer washer, install the turning loop then tighten the bolt to 40 N·m (30 ft. lbs.) (Figure 7).
49. Install the seat belt turning loop cover (Figure 7).
50. Position the B-pillar lower trim panel and engage the retaining clips fully (Figure 6).
51. Position the front and rear door sill scuff plates and engage the retainers (Figure 5).

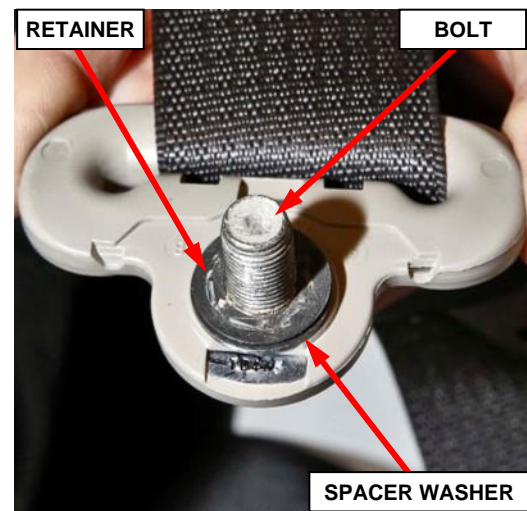

**Figure 19 – Turning Loop Bolt**

**WARNING: Do not connect the negative battery cable at this time. The Supplemental Restraint System (SRS) Verification Test procedure should be performed following service of any SRS component.**

**NOTE: The following procedure should be performed using a diagnostic scan tool to verify proper Supplemental Restraint System (SRS) operation following the service or replacement of any SRS component. Refer to the appropriate diagnostic procedures.**

52. During the following test, the negative cable remains disconnected and isolated from the battery, as it was during the Supplemental Restraint System (SRS) component removal and installation procedures.
53. Be certain that the diagnostic scan tool contains the latest version of the proper diagnostic software. Connect the scan tool to the 16-way Data Link Connector (DLC). The DLC is located on the driver side lower edge of the instrument panel, near the steering column opening cover and outboard of the steering column.
54. Transition the status of the ignition switch (also known as the Keyless Ignition Node/KIN or Ignition Node Module/IGNM) to ON and exit the vehicle with the scan tool.
55. Check to be certain that nobody is in the vehicle, then connect the negative cable to the battery.
56. Using the scan tool, read and record the active (current) Diagnostic Trouble Code (DTC) data.
57. Next, use the scan tool to read and record any stored (historical) DTC data.
58. If any SRS related DTC is found in the previous two steps, refer to the appropriate diagnostic information.
59. Use the scan tool to erase the stored DTC data. If any problems remain, the stored DTC data will not erase. Refer to the appropriate diagnostic information to diagnose any stored DTC that will not erase. If the stored DTC information is successfully erased, continue to the next step.
60. Transition the status of the ignition switch to OFF for about 15 seconds, and then back to ON. Observe the airbag indicator in the instrument cluster. It should light from four to six seconds, and then go out. This indicates that the SRS is functioning normally and that the repairs are complete. If the airbag indicator fails to light, or lights and stays ON, there is still an active SRS fault or malfunction. Refer to the appropriate diagnostic information to diagnose the problem.
61. Install the front seat headrests (Figure 4).
62. Position the visor supports (1) onto the headliner and install the screws into the mounting clips (Figure 2).
63. If equipped with illuminated vanity mirror, connect the wire harness connector.
64. Position the visor to the headliner and install the screws (2) that secure the visor to the roof panel. Tighten the screws to 6 N·m (53 in. lbs.) (Figure 2).
65. Position the locating tab of the A-pillar trim panel (2) into the slot located in the top of the instrument panel (Figure 1).
66. Install the A-pillar trim panel onto the A-pillar (1) and install the two bolts (4). Tighten the bolts to 5 N·m (44 in. lbs.) (Figure 1).

**SAFETY RECALL**  
NORTH AMERICA  
**Curtain Airbag Inflator**



Reference: C7C / NHTSA 25V-824

FCA US LLC

- 
67. Close the two fastener covers (3) located in the A-pillar trim panel (Figure 1).
  68. Install the door seals around the door openings.
  69. Return the vehicle to the customer or inventory.

**B. Mega Cab**

1. Using a small flat-bladed tool, carefully open the two fastener covers (3) located in the A-pillar trim panel (2) (Figure 20).
2. Remove the two bolts (4) that secure the A-pillar trim panel to the A-pillar (1) and remove the trim panel (Figure 20).

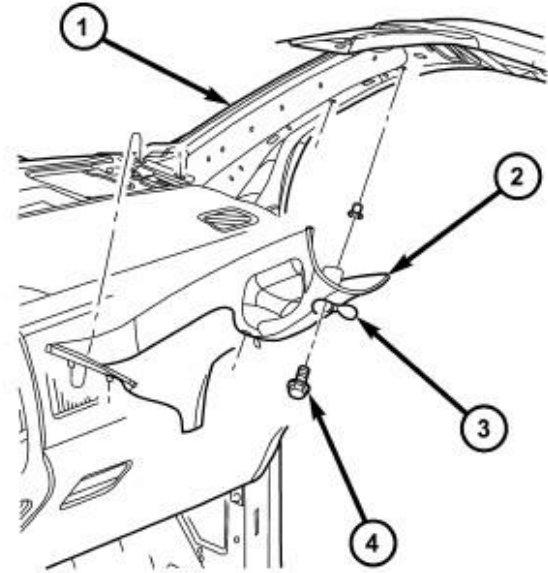

80d407a9

**Figure 20 – A-Pillar**

3. Separate the visor from the support (1) then remove the screw and remove the visor support (Figure 21).
4. Remove the visor screws (2) then remove the visor (Figure 21).

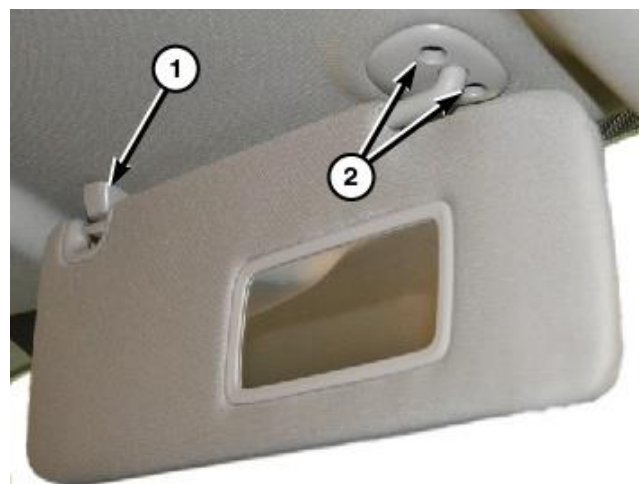

**Figure 21 – Visors**

5. Using a small flat bladed tool or equivalent, release the retaining tabs (1) and separate the visor from the headliner (Figure 22).

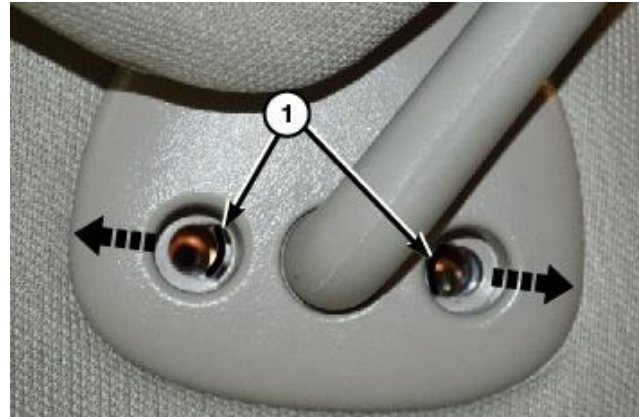
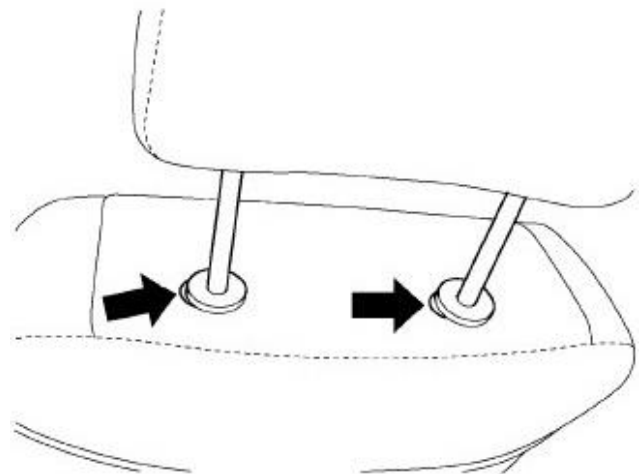

**Figure 22 – Visors**

6. Disconnect the visor electrical connector if equipped.

**NOTE:** In some cases, the wire harness for the visor vanity mirror may be glued to the top side of the headliner and may be a little difficult to release.

7. Tilt seat backs all the way back. Push in the buttons on front seat headrest sleeves then pull the headrest up and remove (Figure 23).



8120dd63

**Figure 23 – Head Rest**

8. Move the seats all the way forward and tilt the seatbacks forward.

9. Release the front and rear door sill scuff plates on either side of the B pillar lower trim panel to allow for removal of the B-pillar lower trim panel (Figure 24).



**Front Door Sill**



**Rear Door Sill**

**Figure 24 – Door Sill Scuff Plates**

10. Release the retaining clips and remove the B-pillar lower trim panel to allow for removal of the B-pillar upper trim panel (Figure 25).

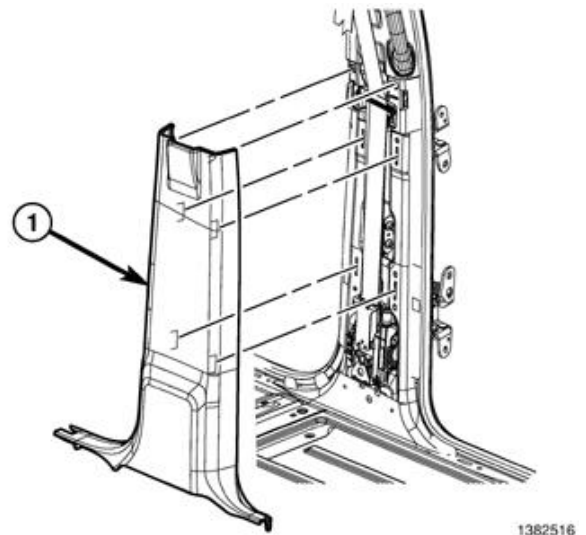

**Figure 25 – B-Pillar Lower Trim Panel**

11. On the B-pillar, separate the seatbelt turning loop cover then remove the turning loop bolt (Figure 26).

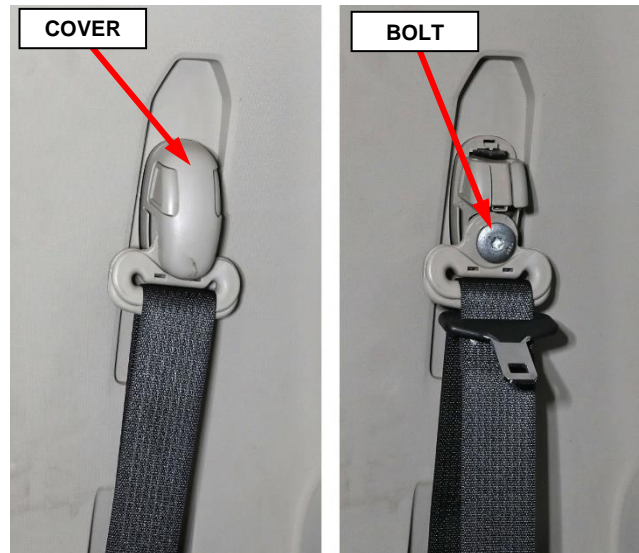
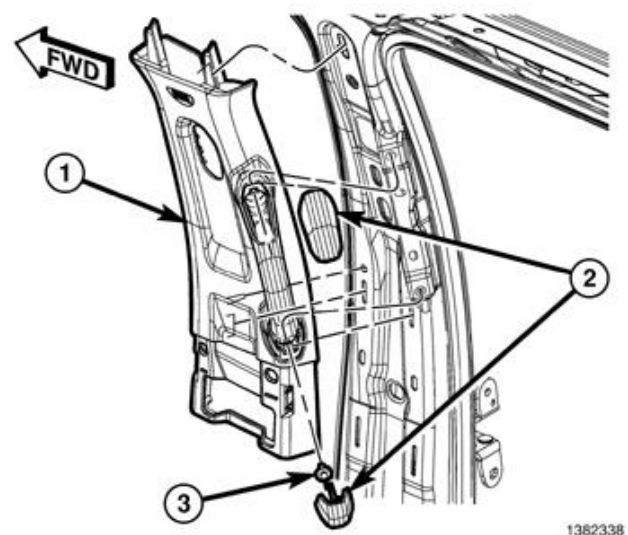

**Figure 26 – Seat Belt Turning Loop**

12. On the B-pillar, use a small flat-bladed tool to carefully open the two fastener covers (2) located on the grab handle (Figure 27).

13. Remove the two bolts (3) that secure the grab handle to the B pillar (Figure 27).

14. Using a trim stick C-4755 or equivalent, release the retaining clips that secure the B pillar upper trim panel (1) then position the trim panel out of the way. It is not necessary to remove the seat belt from the trim panel (Figure 27).



**Figure 27 – B-Pillar Upper Trim Panel**

15. Fold the rear seat backs down.
  
16. Release the upper retaining clips of the lower C-pillar trim panel to allow for removal of the upper C pillar trim panel (Figure 28).



**Figure 28 – C-Pillar Lower Trim Panel**

17. On the C-pillar, lift the seat belt turning loop cover then remove the turning loop bolt (Figure 29).

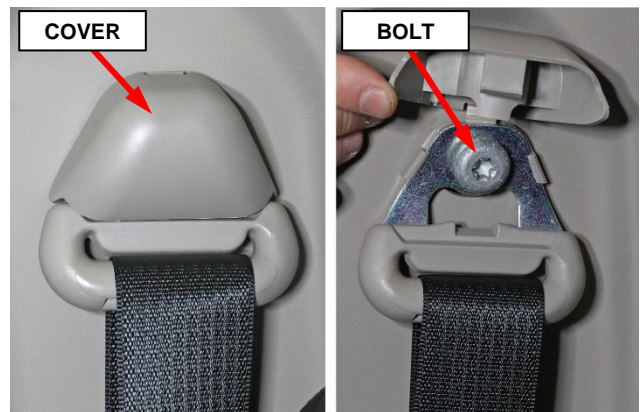

**Figure 29 – Seat Belt Turning Loop**

18. Using a trim stick or equivalent, release the B-pillar airbag applique then remove the screw that secures the upper trim panel (Figure 30).



**Figure 30 – C-Pillar Upper Trim Panel Fasteners**

19. Release the retaining clips and remove the C-pillar upper trim panel (1) (Figure 31).

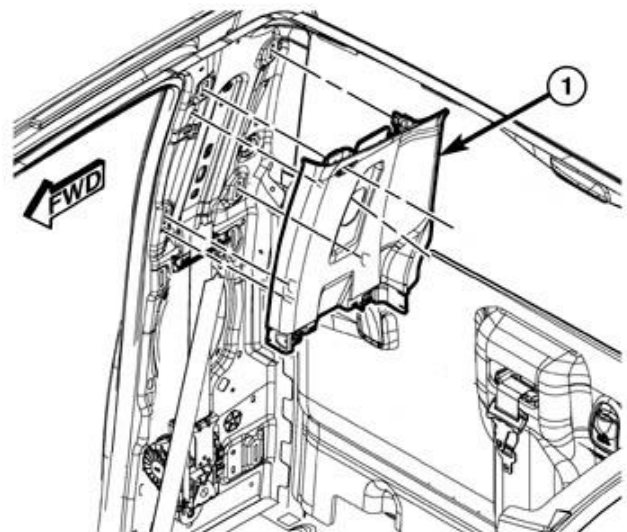

**Figure 31 – C-Pillar Upper Trim Panel**

20. Recline the front seat backs to allow for room to lower the headliner.

21. Disconnect and isolate the negative battery cable. If equipped with an Intelligent Battery Sensor (IBS), disconnect the IBS connector first before disconnecting the negative battery cable. Wait two minutes for the system capacitor to discharge before further service.

**WARNING:** To avoid serious or fatal injury on vehicles equipped with airbags, disable the Supplemental Restraint System (SRS) before attempting any steering wheel, steering column, airbag, seat belt tensioner, impact sensor or instrument panel component diagnosis or service. Disconnect and isolate the battery negative (ground) cable, then wait two minutes for the system capacitor to discharge before performing further diagnosis or service. This is the only sure way to disable the SRS. Failure to take the proper precautions could result in accidental airbag deployment.

**WARNING:** To avoid serious or fatal injury when removing a deployed airbag, rubber gloves, eye protection, and a long-sleeved shirt should be worn. There may be deposits on the airbag unit and other interior surfaces. In large doses, these deposits may cause irritation to the skin and eyes.

**WARNING:** To avoid serious or fatal injury, use extreme care to prevent any foreign material from entering the side curtain airbag, or becoming entrapped between the side curtain airbag cushion and the headliner. Failure to observe this warning could result in occupant injuries upon airbag deployment.

**NOTE:** The following procedure is for replacement of an ineffective or damaged side Curtain Airbag (CAB). If the airbag is ineffective or damaged, but not deployed, review local ordinances regarding recommended procedures for handling and disposal of Non-Deployed Supplemental Restraints.

**NOTE:** If a side curtain airbag is being removed, but has not been deployed, the headliner does not need to be removed from the passenger compartment. Lowering the headliner and resting it on the seat backs will allow enough clearance to remove the side curtain airbag from the vehicle.

**CAUTION:** Hands should be clean or clean cloth gloves used when handling the visors and headliner to avoid marks or damage.

22. If equipped with DVD monitor, remove the screws (2) and separate the monitor (1) from the roof (Figure 32).

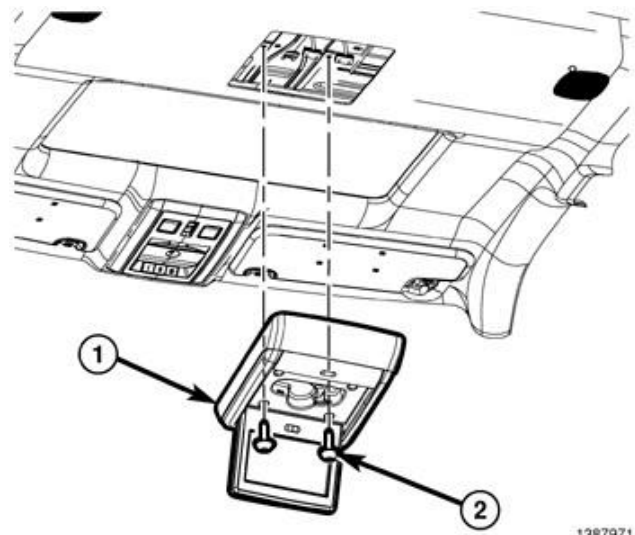

**Figure 32 – Rear Seat DVD Monitor**

23. If equipped with DVD monitor, disconnect the electrical connectors (1) (Figure 33).

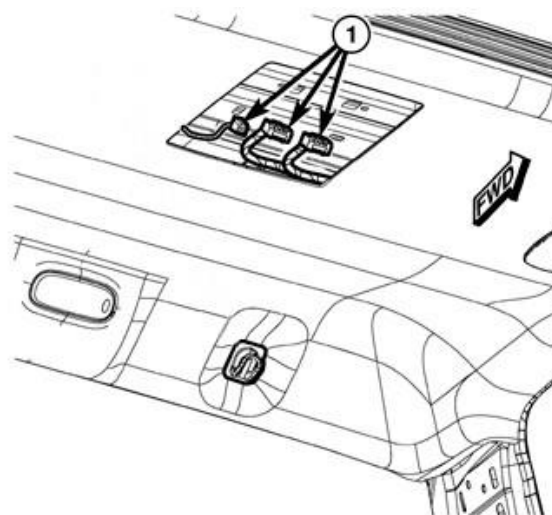

**Figure 33 – DVD Monitor Electrical Connectors**

24. Using a small flat bladed tool, open the coat hook screw cover (2) then remove the screw and coat hook (Figure 34).

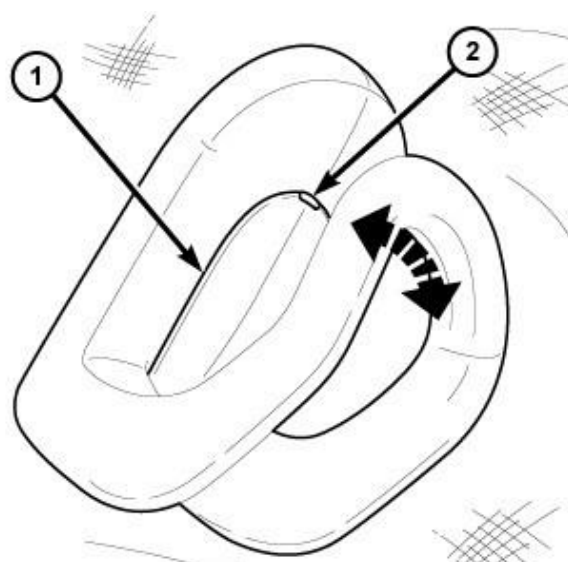

**Figure 34 – Coat Hook**

- 25. As necessary, release the headliner wiring harness clips (3) from the A-pillar to allow enough wiring harness slack for lowering the headliner (Figure 35).
- 26. Release the door seals from the door openings to allow for lowering of the headliner.

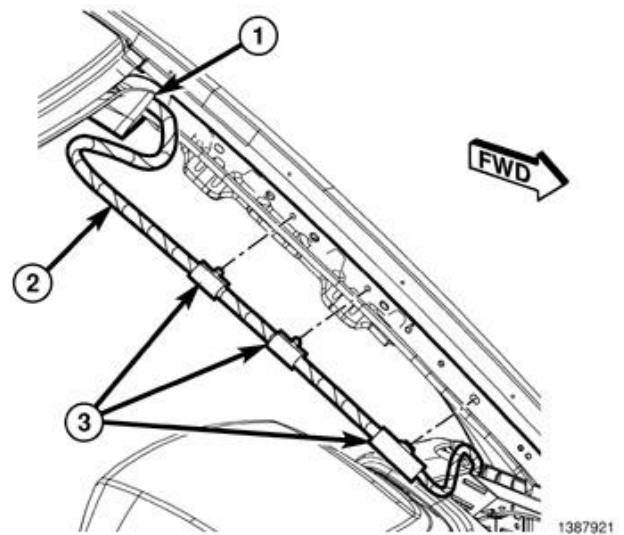

**Figure 35 – Headliner Harness**

- 27. Carefully lower the headliner (2) allowing it to rest on the seat backs and instrument panel (Figure 36).

**CAUTION:** Disconnect any wiring harness electrical connectors (1) as necessary to allow enough wiring harness slack while lowering headliner. It will not be necessary to remove the headliner from the vehicle (Figure 36).

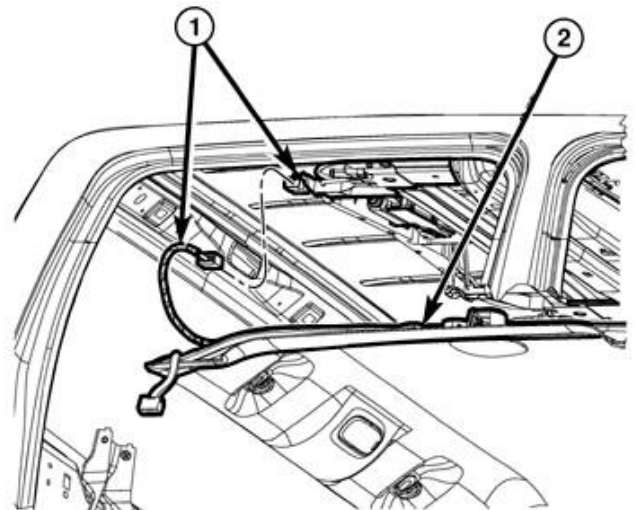

**Figure 36 – Headliner Harness**

- 28. Obtain the appropriate replacement CAB for the vehicle based on its VIN.

29. The body wire harness connector (5) is secured by integral latches to the connector receptacle on the inflator (4). Pinch both latches firmly, then pull the connector straight out from the airbag inflator to disconnect it from the connector receptacle (Figure 37).
30. Remove the seven bolts (8) that secure the side curtain airbag (6) to the inner roof rail and A-pillar (Figure 37).
31. Disengage the push-in retainer (9) that secures the side curtain airbag tether to the inner A-pillar (1) and the two push-in retainers (7) that secure the side curtain airbag to the inner roof rail (Figure 37).
32. Slide the inflator rearward far enough to disengage the T-tab at the front of the inflator bracket from the keyed T-slot in the inner roof rail over the rear door opening (Figure 38).
33. Remove the CAB (6) from the vehicle as a unit and **DISCARD** following local ordinances and recommended procedures for handling and disposal of Non-Deployed Supplemental Restraints (Figure 37). Provided packaging is not authorized for the transport of the recalled CAB Module. Parts will need to be either deployed on-site or transported in alternative approved containers.

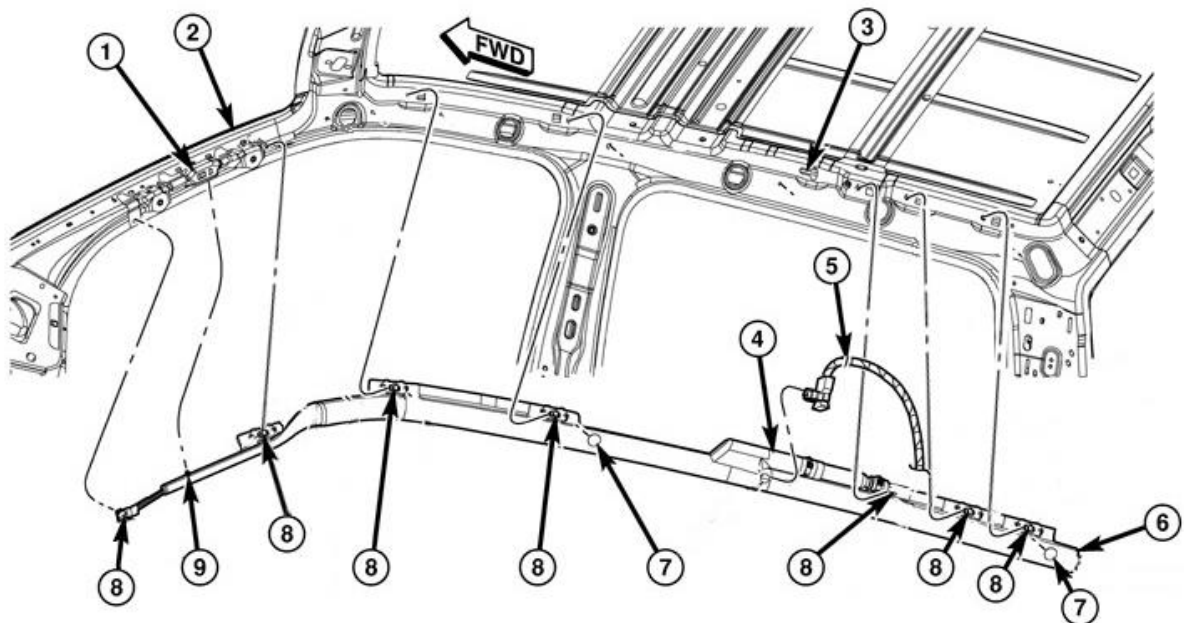

**Figure 37 – Side Curtain Airbag**

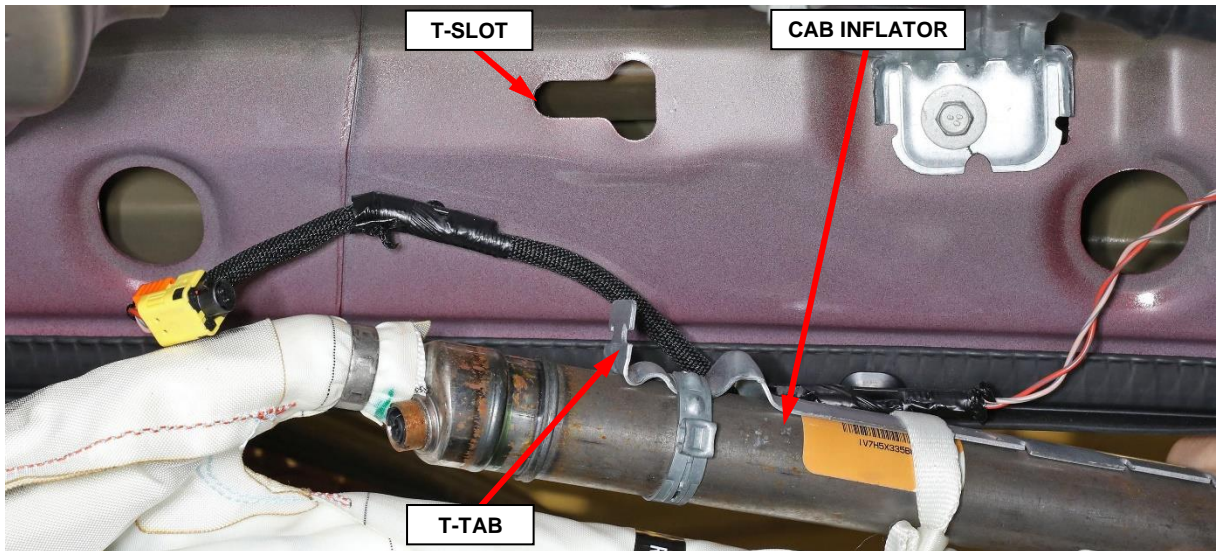

**Figure 38 – CAB Inflator T-Tab and Inner Roof Rail T-Slot**

34. Check to be certain that the spring nuts are properly installed in the inner roof rail and that they are in good condition.
35. Position the **NEW** CAB (6) into the vehicle as a unit (Figure 37).
36. Insert the T-tab at the front of the inflator bracket into the keyed T-slot in the inner roof rail over the rear door opening and slide the inflator forward to engage it (Figure 38).
37. Engage the two push-in retainers (7) that secure the side curtain airbag to the inner roof rail and ensure the tether is not twisted then engage the push-in retainer (9) that secures the side curtain airbag front tether to the assist handle bracket on the inner A-pillar (1) (Figure 37).
38. Working from rear to front, install and tighten the seven bolts (8) that secure the side curtain airbag (6) to the inner roof rail and A-pillar. Tighten the bolts to 7 N·m (62 in. lbs.) (Figure 37).
39. Connect the body wire harness connector (5) for the side curtain airbag to the connector receptacle of the inflator (4). Be certain that each connector is fully engaged in its receptacle by listening carefully for a distinct, audible click as the connector latches snap into place (Figure 37).

**CAUTION: Hands should be clean or clean cloth gloves used when handling the headliner to avoid damage to the headliner.**

40. Raise the headliner into proper vehicle position and connect any electrical connectors previously disconnected from the headliner (Figure 36).

**CAUTION: Be certain to avoid any wiring or drain tube interference.**

41. Position the coat hooks (5) onto the headliner and install the screws tightening securely into the mounting clips then close the screw cap fully (Figure 34).
42. Reattach any headliner wiring harness clips (3) removed from the A-pillar to allow slack while lowering headliner (Figure 35).
43. If equipped with DVD monitor, connect the DVD monitor electrical connectors (1) (Figure 33). Position the DVD monitor to the roof then install and tighten the screws (2) (Figure 32).

**WARNING:** Do not connect the negative battery cable at this time. The Supplemental Restraint System (SRS) Verification Test procedure should be performed following service of any SRS component.

**NOTE:** The following procedure should be performed using a diagnostic scan tool to verify proper Supplemental Restraint System (SRS) operation following the service or replacement of any SRS component. Refer to the appropriate diagnostic procedures.

44. During the following test, the negative cable remains disconnected and isolated from the battery, as it was during the Supplemental Restraint System (SRS) component removal and installation procedures.
45. Be certain that the diagnostic scan tool contains the latest version of the proper diagnostic software. Connect the scan tool to the 16-way Data Link Connector (DLC). The DLC is located on the driver side lower edge of the instrument panel, near the steering column opening cover and outboard of the steering column.
46. Transition the status of the ignition switch (also known as the Keyless Ignition Node/KIN or IGnition Node Module/IGNM) to ON and exit the vehicle with the scan tool.
47. Check to be certain that nobody is in the vehicle, then connect the negative cable to the battery.
48. Using the scan tool, read and record the active (current) Diagnostic Trouble Code (DTC) data.
49. Next, use the scan tool to read and record any stored (historical) DTC data.
50. If any SRS related DTC is found in the previous two steps, refer to the appropriate diagnostic information.
51. Use the scan tool to erase the stored DTC data. If any problems remain, the stored DTC data will not erase. Refer to the appropriate diagnostic information to diagnose any stored DTC that will not erase. If the stored DTC information is successfully erased, continue to the next step.
52. Transition the status of the ignition switch to OFF for about 15 seconds, and then back to ON. Observe the airbag indicator in the instrument cluster. It should light from four to six seconds, and then go out. This indicates that the SRS is functioning normally and that the repairs are complete. If the airbag indicator fails to light, or lights and stays ON, there is still an active SRS fault or malfunction. Refer to the appropriate diagnostic information to diagnose the problem.

53. Raise the front seat backs and position the seats forward.
54. Install the C-pillar upper trim panel (1) and engage the retaining clips fully (Figure 31).
55. Install and tighten the screws that secure the C-pillar upper trim panel then install the airbag applique covers (Figure 30).
56. Remove and **DISCARD** the bolt retainer and the bolt from the seat belt turning loop, save the spacer for reuse (Figure 39).
57. Using a **NEW** bolt and reusing the spacer washer, install the turning loop then tighten the bolt to 40 N·m (30 ft. lbs.) (Figure 29).
58. Install the seat belt turning loop cover (Figure 29).
59. Position the lower C-pillar trim panel and engage the retaining clips fully (Figure 28).

NOTE: Ensure that all C-pillar fasteners are installed/engaged properly.

60. Install the B-pillar upper trim panel (1) and engage the retaining clips fully (Figure 27).
61. Install the grab handle bolts and tighten to 5 N·m (44 in. lbs.). Close the fastener covers (2) (Figure 27).
62. Remove and **DISCARD** the bolt retainer and the bolt from the seat belt turning loop, save the spacer washer for reuse (Figure 40).
63. Using a **NEW** bolt and reusing the spacer washer, install the turning loop then tighten the bolt to 40 N·m (30 ft. lbs.) (Figure 26).
64. Install the seat belt turning loop cover (Figure 26).
65. Position the B-pillar lower trim panel and engage the retaining clips fully (Figure 25).
66. Position the front and rear door sill scuff plates and engage the retainers (Figure 24).

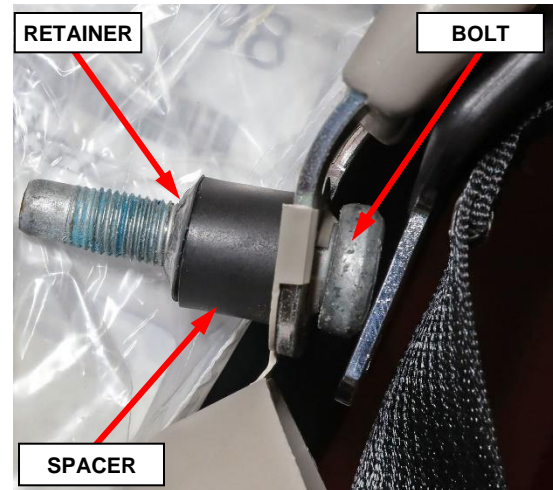

**Figure 39 – Turning Loop Bolt**

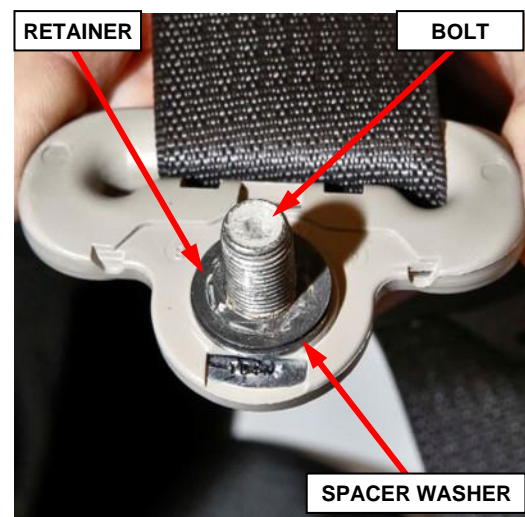

**Figure 40 – Turning Loop Bolt**

67. Install the front seat headrests (Figure 23).
68. Position the visor supports (1) onto the headliner and install the screws into the mounting clips (Figure 21).
69. If equipped with illuminated vanity mirror, connect the wire harness connector.
70. Position the visor to the headliner and install the screws (2) that secure the visor to the roof panel. Tighten the screws to 6 N·m (53 in. lbs.) (Figure 21).
71. Position the locating tab of the A-pillar trim panel (2) into the slot located in the top of the instrument panel (Figure 20).
72. Install the A-pillar trim panel onto the A-pillar (1) and install the two bolts (4). Tighten the bolts to 5 N·m (44 in. lbs.) (Figure 20).
73. Close the two fastener covers (3) located in the A-pillar trim panel (Figure 20).
74. Install the door seals around the door openings.
75. Return the vehicle to the customer or inventory.

This notice applies to your vehicle,

[Model Year and Model]

VIN XXXXXXXXXXXXXXXXXXXX

C7C/NHTSA 25V-824

LOGO

VEHICLE PICTURE

#### YOUR SCHEDULING OPTIONS

- 1. RECOMMENDED OPTION**  
Call your authorized Chrysler / Jeep® / Dodge / RAM Dealership.
- 2. Call the FCA Recall Assistance Center at 1-800-853-1403.** An agent can confirm part availability and help schedule an appointment.
- 3. Visit recalls.mopar.com, scan the QR code below, or download the Mopar Owner's Companion App.**

QR Code

Get access to recall notifications, locate your nearest dealer, and more through this website or Mopar Owner's Companion App. You will be asked to provide your Vehicle Identification Number (VIN) to protect and verify your identity. The last eight characters of your VIN are provided above.

#### DEALERSHIP INSTRUCTIONS

Please reference Safety Recall C7C.

# IMPORTANT SAFETY RECALL

## Curtain Airbag Inflator

Dear [Name],

This notice is sent to you in accordance with the National Traffic and Motor Vehicle Safety Act.

FCA US LLC has decided that a defect, which relates to motor vehicle safety, exists in certain [2019 model year (DS) Ram 1500 Pickup Classic, 2019 model year (DJ) Ram 2500 Pickup, and 2019 model year (D2) Ram 3500 Pickup] vehicles.

It is extremely important to take steps now to repair your vehicle to ensure the safety of you and your passengers.

#### WHY DOES MY VEHICLE NEED REPAIRS?

The Curtain Airbag (CAB) inflators on your vehicle <sup>[1]</sup> may rupture, resulting in compressed gas rapidly escaping from the inflator and material, such as headliner or trim pieces, being propelled into the vehicle. **Material being propelled into an occupied vehicle may cause injury.**

#### HOW DO I RESOLVE THIS IMPORTANT SAFETY ISSUE?

FCA US LLC will repair your vehicle <sup>[2]</sup> free of charge (parts and labor). To do this, your dealer will replace the driver's side CAB. The estimated repair time is 3 hours. In addition, your dealer will require your vehicle for proper check-in, preparation, and check-out during your visit, which may require more time. Your time is important to us, so we recommend that you schedule a service appointment to minimize your inconvenience. Ask your dealer for alternate transportation options while your vehicle is in service. Please bring this letter with you to your dealership.

**TO SCHEDULE YOUR FREE REPAIR,  
CALL YOUR CHRYSLER, JEEP®, DODGE OR RAM DEALER TODAY**

#### WHAT IF I ALREADY PAID TO HAVE THIS REPAIR COMPLETED?

If you have already experienced this specific condition and have paid to have it repaired, you may visit [www.fcarecallreimbursement.com](http://www.fcarecallreimbursement.com) to submit your reimbursement request online. <sup>[3]</sup> Once we receive and verify the required documents, reimbursement will be sent to you within 60 days. If you have had previous repairs performed and/or already received reimbursement, you may still need to have the recall repair performed.

We apologize for any inconvenience, but are sincerely concerned about your safety. Thank you for your attention to this important matter.

Customer Assistance/Field Operations  
FCA US LLC



**Mr. Mrs. Customer**  
**1234 Main Street**  
**Hometown, MI 48371**

[1] If you no longer own this vehicle, please help us update our records. Call the FCA Recall Assistance Center at 1-800-853-1403 to update your information.

[2] If your dealer fails or is unable to remedy this defect without charge and within a reasonable time, you may submit a written complaint to the Administrator, National Highway Traffic Safety Administration, 1200 New Jersey Ave., S.E., Washington, DC 20590, or you can call the toll-free Vehicle Safety Hotline at 1-888-327-4236 (TTY 1-888-275-9171), or go to [safercar.gov](http://safercar.gov).

[3] You can also mail in your original receipts and proof of payment to the following address for reimbursement consideration: FCA Customer Assistance, P.O. Box 21-8004, Auburn Hills, MI 48321-8007, Attention: Recall Reimbursement.

Note to lessors receiving this recall notice: Federal regulation requires that you forward this recall notice to the lessee within 10 days.