

# SAFETY RECALL

**Mack Trucks Inc.**  
Greensboro, NC USA



---

Date	Number	Release	Page
12.2025	<b>SC0489</b>	<b>01</b>	<b>1(4)</b>

## **Load Lock Clamp PR**

### **RECALL INFORMATION**

(December, 2025)

Certain Mack Pioneer (PR) vehicles are equipped with load lock clamps on the back of the cab that may experience breakage due to early life failures. Load lock clamp failures may result in load lock bars being unsecured during vehicle operation. Loose or unsecured load lock bars may cause injury or increase the risk of a crash.

Mack Trucks has not received any complaints or reports of vehicle crashes because of this safety defect; therefore, Mack considers this as a proactive measure to protect the public and Mack's customers from the potential risk associated with this defect.

To resolve this safety issue, please follow the instructions in this document to remove the load lock clamp. A new load lock clamp is being developed and once they are available there will be a follow up service campaign to install a new load lock clamp.

### **VEHICLES AFFECTED**

Certain 2025-2026 Pioneer (PR) Model vehicles manufactured from October 22, 2024, through October 14, 2025.

### **VEHICLE QUANTITY**

There are 80 vehicles affected by this recall (46 U.S., 34 Canada).

### Repair Instructions

1. Secure vehicle for service.
2. Apply the parking brake.
3. Place the transmission in neutral or park.
4. Install wheel chocks.

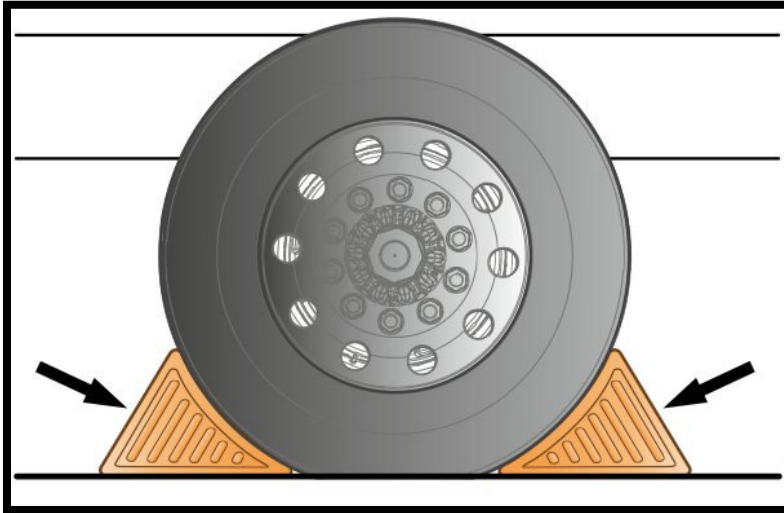

5. Locate the load lock clamp at back of cab.

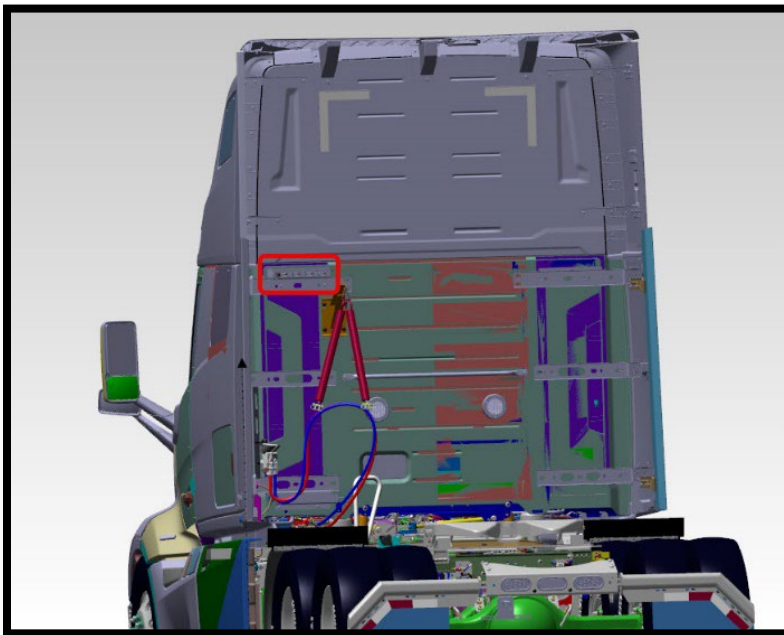

6. Remove composite load lock clamp and scrap.

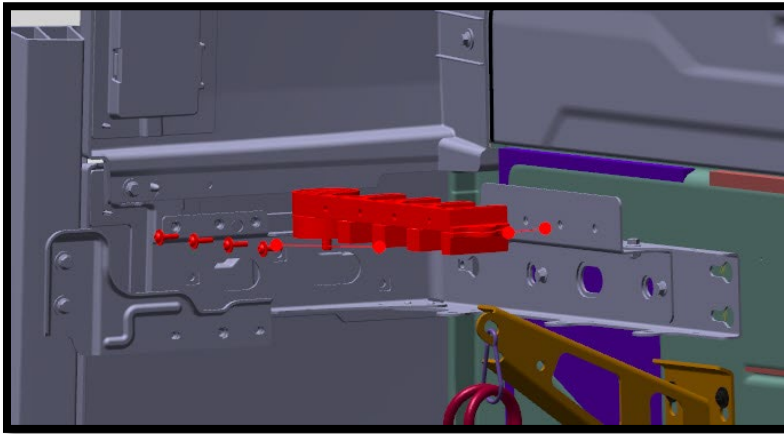

Note: Do not disturb mounting bracket.

7. Remove wheel chocks.

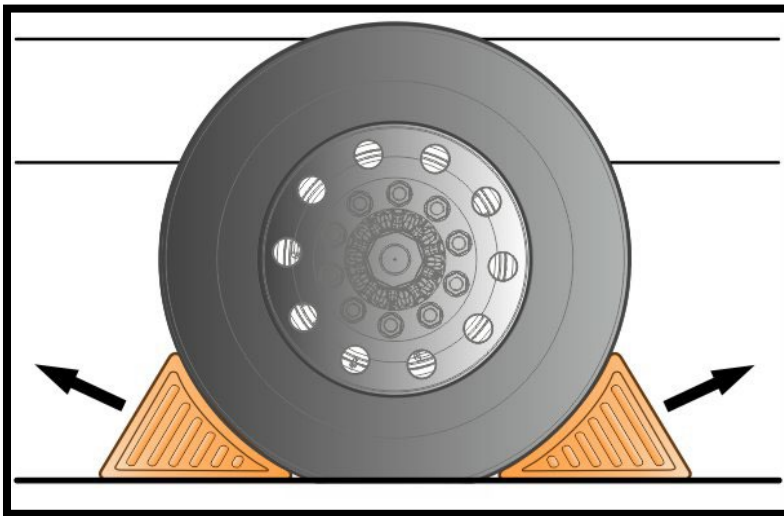

8. Return vehicle to service.

## REIMBURSEMENT

This repair is covered by an authorized Safety Recall. Reimbursement is obtained through the normal claim handling process.	
	<b>UCHP Reimbursement</b>
<b>Claim Type</b> (used only when uploading from the Dealer Business System)	40
<b>Recall Status</b>	
Vehicle repaired per instructions	1-Modified per instructions
<b>Main Labor Codes</b>	
1720-16-09-01 Campaign General (3 x 0.1)	0.3
<b>Causal Part</b>	78652107
<b>Authorization Number</b>	C0511

**Note:** Dealers or the designated representatives are required to perform Safety Recall on all subject vehicles at no charge to the vehicle owner regardless of mileage, age of vehicle or ownership (original purchaser or subsequent purchasers). Whenever vehicles that are subject to a Safety Recall are brought to your dealership for service, it is strongly recommended that every effort be made to perform the recall correction before the vehicle is released to the owner.