



◀ IMPORTANT UPDATE ▶

The attached Technical Instructions have been updated. Refer to the details below.

DATE	TOPIC
11/26/2025	<ul style="list-style-type: none">• Updated calibration Table to show download file name & size
12/18/2025	<ul style="list-style-type: none">• CAL Files available for NX vehicles
2/5/2026	<ul style="list-style-type: none">• Additional CAL File for certain NX vehicles

*The most recent update in the attached TI will be highlighted with a **red box**.*

Please review this notification with your staff to assure that all relevant personnel have been briefed regarding this subject.

Thank you for your cooperation.

**TECHNICAL INSTRUCTIONS
FOR
SAFETY RECALL 25LA06
REPROGRAMMING FOR
CIRCUMFERENCE MONITORING CAMERA CONTROL MODULE
CERTAIN
ES, GX, LC, LS, LX, NX, RX, RZ & TX350**

The repair quality of covered vehicles is extremely important to Lexus. All dealership technicians performing this recall are required to successfully complete the most current version of the E-Learning course “Safety Recall and Service Campaign Essentials”. To ensure that all vehicles have the repair performed correctly; technicians performing this repair are required to currently have completed all of the following courses:

- LIC206A – Electrical Repair 1**

It is the dealership’s responsibility to select technicians that have completed the above courses to perform this repair. Carefully review your resources, the technician skill level, and ability before assigning technicians to this repair. It is important to consider technician days off and vacation schedules to ensure there are properly trained technicians available to perform this repair at all times.

I. OPERATION FLOW CHART

The flow chart is for reference only. **DO NOT** use it in place of the full technical instructions. Follow **ALL** steps as outlined in the full technical instructions to confirm the campaign is completed correctly.

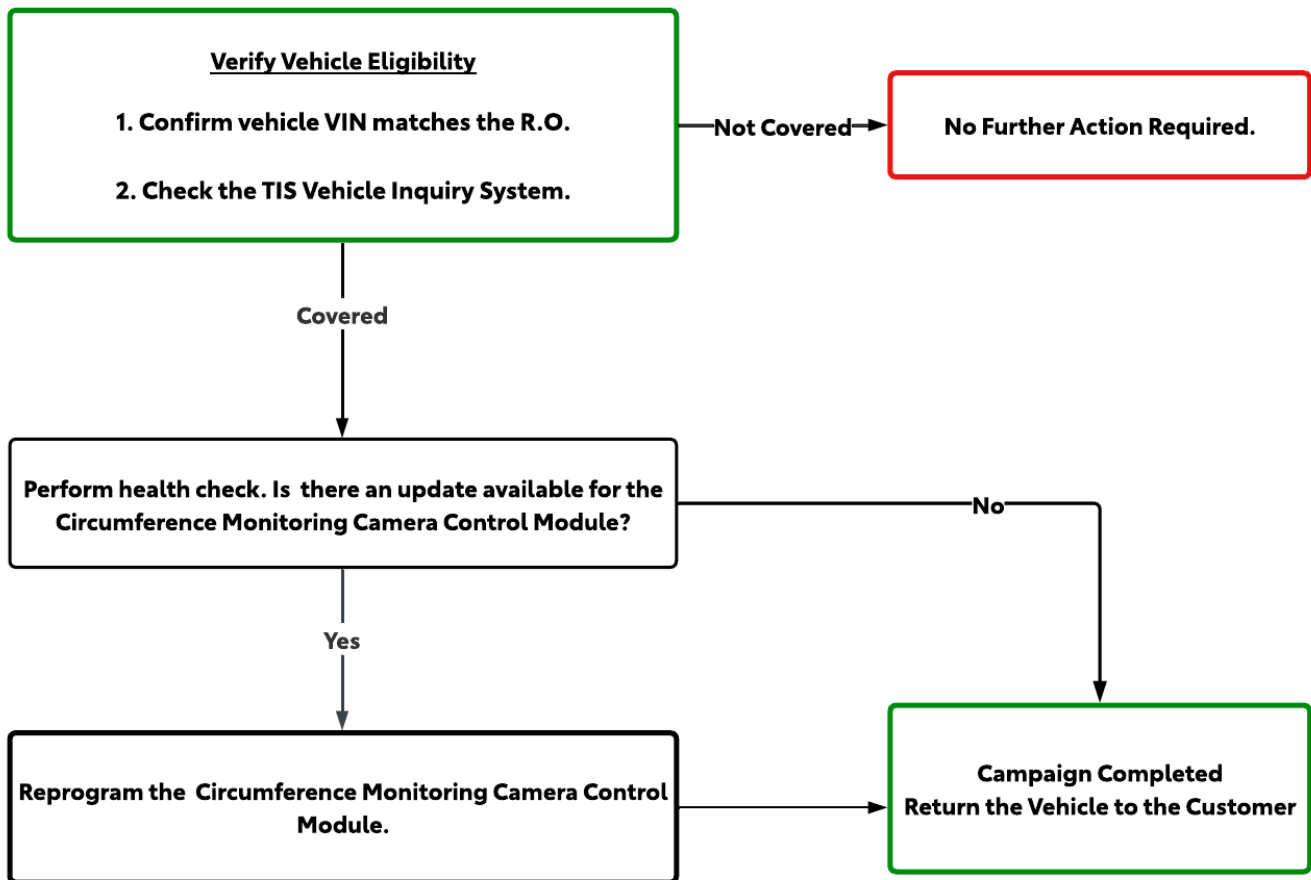

II. IDENTIFICATION OF AFFECTED VEHICLES

1. CHECK VEHICLE FOR CAMPAIGN ELIGIBILITY

- Compare the vehicles VIN to the VIN listed on the Repair Order to ensure they match.
- Check the TIS Vehicle Inquiry System to confirm the VIN is involved in this Campaign, and that it has not already been completed.

HINT:

TMNA warranty will not reimburse dealers for repairs completed on vehicles that are not affected or were previously completed, even by another dealer.

III. PREPARATION

A. TOOLS & EQUIPMENT

- L-SB-0001-18 Rev. 2
- DCA-8000 Battery Diagnostic Station
- GTS+

IV. BACKGROUND

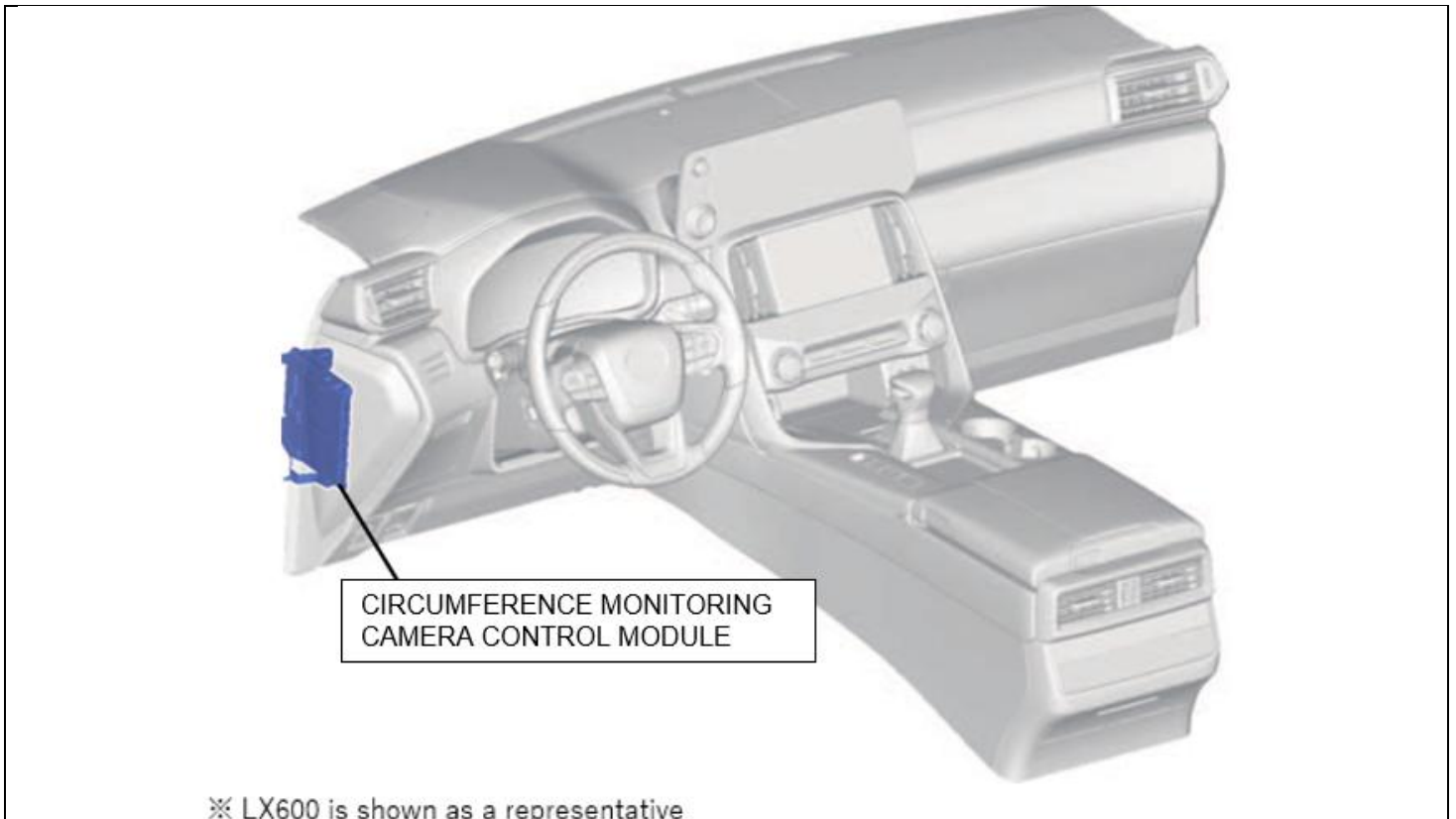

V. SEAFETY PRECAUTIONS

Critical CRITICAL INFORMATION - READ THOROUGHLY

An ECU could be damaged if an error occurs in the communication while reprogramming the ECU. Confirm all work is performed as described in these instructions.

Be sure to connect the personal computer to an external AC power supply.

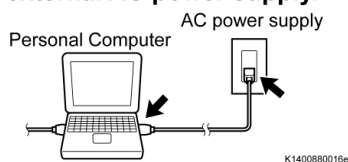

Turn off the screen saver and power saving mode.



1. STABILIZE THE POWER TO THE PERSONAL COMPUTER SIDE

- Be sure to connect the personal computer to an external AC power supply.

NOTICE:

The ECU could be damaged if the battery voltage of the personal computer drops while reprogramming.

- Turn off the screen saver and power saving mode of the personal computer so that the power to the hard disk is kept supplied.

NOTICE:

If the screen saver or power saving mode launches while reprogramming, the communication may be disconnected, resulting in the damage of the ECU.



c) **DO NOT** block the ventilation opening for the cooling fan of the personal computer.

NOTICE:

If the ventilation opening for the cooling fan is blocked with a sheet cover or the like, the personal computer may be heated excessively, causing the operation of the personal computer to stop.

Due to the stop of the operation, the communication for reprogramming signals could be stopped, resulting in the damage of the ECU.

VI. CIRCUMFERENCE MONITORING CAMERA CONTROL MODULE SYSTEM CALIBRATION ID VERIFICATION

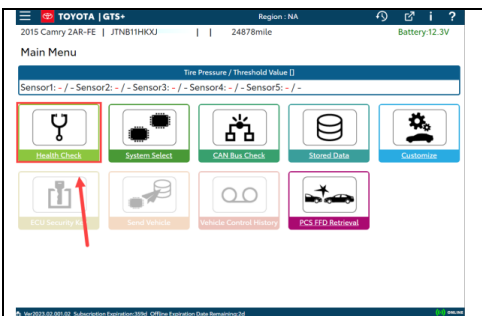

1. CHECK FOR DTC'S

a) Using a GTS+, click the "Health Check" button on the Main Menu.

HINT:

This Campaign covers only the software update to the circumference monitoring camera control module System, as detailed in these instructions. It does not cover the diagnosis or replacement of any other green systems on the vehicle.

2. CHECK CURRENT CALIBRATION

- a) Locate the "Update" column of the "Calibration Information" for the circumference monitoring camera control module system on the "Health Check Result" screen.
- b) Determine the status of an available update; indicated by a YES or NO.

HINT:

If the CIDs indicate 'Yes', proceed with the update procedure.

System	Calibration	Configure	RoB	DTC
Home Control	-	-	●	0
Circumference Monitoring Camera Control Module	8679F4802000 8679G4807000	Yes	●	0
Pre-Collision System	-	No	●	0
D-Door Motor	-	No	-	0
P-Door Motor	-	No	-	0
RL-Door Motor	-	No	-	0
RR-Door Motor	-	No	-	0
Driver Seat	-	No	-	0
Master Switch	-	No	-	0
Sliding Roof	-	No	-	0
Combination Meter	8381G0E30000 8381F0E12000	No	-	0

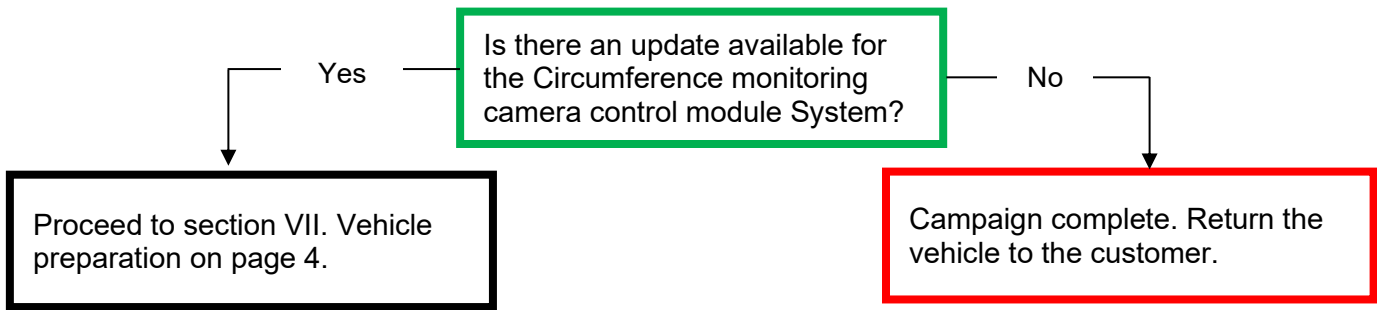

◀ CRITICAL MESSAGE ▶

It is critical that L-SB-0001-18 Rev. 2 in addition to the Technical Instructions for this Recall [or LSC/CSC] are followed. This TSB outlines all steps necessary to prevent reprogramming failure. Toyota will not provide reimbursement coverage for reprogramming failures if this TSB is not followed. If you have a reprogramming failure that requires PARKING ASSIST COMPUTER replacement and the Technical Instructions and TSB were followed correctly, please create a digital TAS case with all information related to the failure. If sufficient reporting is received related to re-flash failure, there will be consideration for reimbursement.

VII. VEHICLE PREPERATION

1. VEHICLE PREPERATION

a) Confirm the following conditions:

- Vehicle in the IG position (READY OFF).
- Transaxle in Park.
- Parking brake engaged.
- Turn off all electrical accessories (i.e. climate control, audio system, etc.)
- Headlight switch in the DRL OFF position. (w/ DRL OFF position)
- Windshield wiper switch in the OFF position.

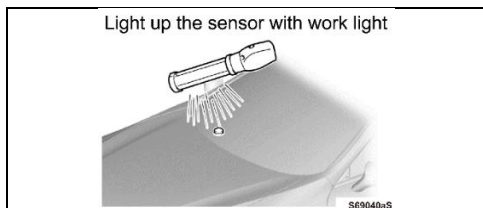

b) When the vehicle has no "OFF position" in the light control switch:

- 1) Turn the IG ON.
- 2) Set the light control switch to the AUTO position and make sure that the exterior lights are turned on.
- 3) Light up the automatic light control sensor with work light to keep the exterior lights turned off.

2. FOR HYBRID VEHICLES DISABLE THE ELECTRIC RADIATOR FAN BY UNPLUGGING THE CONNECTOR.



3. CONNECT THE 12V BATTERY TO A POWER SUPPLY

- a) Connect the DCA-8000 or other type of a power supply (not a battery charger) to the 12V battery.
- b) Tap the Reflash icon from the Main Menu screen of the DCA-8000.

Critical

A power supply MUST be used during reprogramming. ECU damage will occur if the battery voltage is not properly maintained during this re-flash procedure.

NOTICE:

A power supply must be connected directly to the 12V battery terminals and NOT the remote jump posts under the hood (if equipped).

4. VERIFY GTS+ SETUP

- a) Verify that the GTS+ meets the following conditions:
 - The latest version of software is loaded.
 - The GTS+ battery is fully charged. If not, connect the GTS+ to a 120V source.
 - The DLC III cable is in good condition.

Critical

The GTS+'s battery voltage must also be maintained during the re-flash procedure. If necessary, plug the GTS+ into a 120V outlet during this procedure.

NOTICE:

If the GTS+ communication with the vehicle fails during the re-flash procedure, the Circumference monitoring camera control module will be damaged.

VIII. UPDATE CALIBRATION

1. CONFIRM THE CALIBRATION ID

- a) Confirm the current calibration ID in the Circumference monitoring camera control module System.

The screenshot shows the GTS+ software interface. At the top, it displays 'GTS+ ONLINE', 'VIM : DST-010', 'Vehicle : NA', and '1492044@01000'. Below this, it shows '2023 XXXXXXXX' and '1600mile' with a 'Battery:14.4V' indicator. A 'Health Check Result' section is visible. The main table shows calibration data for various systems. The 'Circumference Monitoring Camera Control Module' is highlighted with a green circle, showing calibration IDs '8679F4802000' and '8679G4807000' (both circled in red), a 'Configure' status of 'Yes' (circled in green), and a 'RoB' status of 'Yes' (green dot). Other systems listed include Lane Control, Pre-Collision System, D-Door Motor, P-Door Motor, RL-Door Motor, RR-Door Motor, Driver Seat, Master Switch, Sliding Roof, and Combination Meter. The bottom of the screen shows various icons and a footer with 'Ver2025.03.003.01 Subscription Expiration:98d' and 'Vehicle ID:12532 ONLINE'.

System	Calibration	Configure	RoB	DTC
Lane Control				
Circumference Monitoring Camera Control Module	8679F4802000 8679G4807000	Yes	Yes	0
Pre-Collision System	-	No	Yes	0
D-Door Motor	-	No	-	0
P-Door Motor	-	No	-	0
RL-Door Motor	-	No	-	0
RR-Door Motor	-	No	-	0
Driver Seat	-	No	-	0
Master Switch	-	No	-	0
Sliding Roof	-	No	-	0
Combination Meter	8381G0E30000 8381F0E12000	No	-	0

Please note that some vehicles might show up to 3 current calibration IDs but not all will get updated. The calibration IDs to re-flash in this campaign are as shown in the table below. Match as many Current CAL IDs from the vehicle to select the correct **New** CAL file from the table below. For vehicles that show more than one New CAL ID, only one file is required for the update.

Circumference Monitoring Camera Control Module System			
Model	Current Calibration IDs	<u>New</u> Calibration ID	File Name - Size
ES	8679F3344001 8679F3344012	8679F3344201 8679F3344311	L-0046-25.cuw - 273MB
	8679F3344101 8679F3344211	8679F3344201 8679F3344311	L-0047-25.cuw - 271MB
	8679F3344101 8679F3344111	8679F3344201 8679F3344311	L-0048-25.cuw - 271MB
	8679F3344001 8679F3346012	8679F3344201 8679F3346311	L-0049-25.cuw - 272MB
	8679F3344101 8679F3346211	8679F3344201 8679F3346311	L-0050-25.cuw - 271MB
	8679F3344101 8679F3346111	8679F3344201 8679F3346311	L-0051-25.cuw - 271MB
	8679F3344001 8679F3350012	8679F3344201 8679F3350311	L-0052-25.cuw - 273MB
	8679F3344101 8679F3350211	8679F3344201 8679F3350311	L-0053-25.cuw - 271MB
	8679F3344101 8679F3350111	8679F3344201 8679F3350311	L-0054-25.cuw - 271MB
	8679F3344001 8679F3352012	8679F3344201 8679F3352311	L-0055-25.cuw - 272MB
	8679F3344101 8679F3352211	8679F3344201 8679F3352311	L-0056-25.cuw - 271MB
	8679F3344101 8679F3352111	8679F3344201 8679F3352311	L-0057-25.cuw - 271MB
GX	8679G6015100	8679G6054000	L-0058-25.cuw - 266MB
	8679G6019100	8679G6058000	L-0059-25.cuw - 266MB
	8679G6017100	8679G6056000	L-0060-25.cuw - 266MB
	8679G6020100	8679G6059000	L-0061-25.cuw - 266MB

LC	8679F1102011	8679F1102211	L-0062-25.cuw - 266MB
	8679F1102111	8679F1102211	L-0063-25.cuw - 266MB
LS	8679F5042111	8679F5042211	L-0071-25.cuw - 266MB
	8679F5042011	8679F5042211	L-0072-25.cuw - 266MB
	8679F5044111	8679F5044211	L-0073-25.cuw - 266MB
	8679F5044011	8679F5044211	L-0074-25.cuw - 266MB
	8679F5046211	8679F5046311	L-0075-25.cuw - 266MB
	8679F5046111	8679F5046311	L-0076-25.cuw - 266MB
	8679F5046011	8679F5046311	L-0077-25.cuw - 266MB
	8679G5006100	8679G5020000	L-0078-25.cuw - 266MB
	8679G5008100	8679G5023000	L-0079-25.cuw - 266MB
	8679G5014000	8679G5027000	L-0080-25.cuw - 266MB
	8679G5010100	8679G5021000	L-0081-25.cuw - 266MB
8679G5012000	8679G5025000	L-0082-25.cuw - 266MB	
LX	8679F6079002 8679F6082011	8679F6079003 8679F6082311	L-0064-25.cuw - 271MB
	8679F6082012	8679F6082311	L-0065-25.cuw - 266MB
	8679F6082111	8679F6082211	L-0066-25.cuw - 266MB
	8679G6022000	8679G6075000	L-0067-25.cuw - 266MB
	8679F60B0011	8679F60B0111	L-0068-25.cuw - 266MB
	8679G6023000	8679G6076000	L-0069-25.cuw - 266MB
	8679G6028000	8679G6081000	L-0070-25.cuw - 266MB
RZ	8679G4603100	8679G4603200	L-0043-25.cuw - 266MB
	8679G46030A0	8679G4603200	L-0044-25.cuw - 266MB
	8679G4607000	8679G4618000	L-0045-25.cuw - 266MB

RX	8679G4810000	8679G4821000	L-0034-25.cuw - 266MB
	8679F4805000 8679G4816000	8679F4808000 8679G4828000	L-0035-25.cuw - 271MB
	8679G4802100	8679G4835000	L-0036-25.cuw - 266MB
	8679G48020A0	8679G4835000	L-0037-25.cuw - 266MB
	8679G4803100	8679G4834000	L-0038-25.cuw - 266MB
	8679G48030A0	8679G4834000	L-0039-25.cuw - 266MB
	8679G4811000	8679G4822000	L-0040-25.cuw - 266MB
	8679F4805000 8679G4817000	8679F4808000 8679G4829000	L-0041-25.cuw - 266MB
TX	8679F4888001 8679F4888011	8679F4888101 8679F4888111	L-0042-25.cuw - 271MB
NX	8679F7824012	8679F7824311	L-0083-25.cuw - 266MB
	8679F7816021 8679F7824012	8679F7816022 8679F7824311	L-0084-25.cuw - 362MB
	8679F7816002 8679F7816021 8679F7824011	8679F7816003 8679F7816022 8679F7824311	L-0085-25.cuw - 369MB
	8679F7816001 8679F7816021 8679F7824011	8679F7816003 8679F7816022 8679F7824311	L-0086-25.cuw - 369MB
	8679F7816101 8679F7824112	8679F7816301 8679F7824411	L-0088-25.cuw - 271MB
	8679F7816101 8679F7824111	8679F7816301 8679F7824411	L-0089-25.cuw - 272MB
	8679F7832012	8679F7832311	L-0090-25.cuw - 266MB
	8679F7816021 8679F7832012	8679F7816022 8679F7832311	L-0091-25.cuw 362MB
	8679F7816002 8679F7816021 8679F7832011	8679F7816003 8679F7816022 8679F7832311	L-0092-25.cuw - 369MB
	8679F7816001 8679F7816021 8679F7832011	8679F7816003 8679F7816022 8679F7832311	L-0093-25.cuw - 369MB
	8679F7816101 8679F7832211	8679F7816301 8679F7832411	L-0094-25.cuw - 271MB

NX	8679F7816101 8679F7832112	8679F7816301 8679F7832411	L-0095-25.cuw - 271MB
	8679F7816101 8679F7832111	8679F7816301 8679F7832411	L-0096-25.cuw - 272MB
	8679G7806100	8679G7833000	L-0097-25.cuw - 266MB
	8679G7813100	8679G7839000	L-0098-25.cuw - 266MB

Important:

For specific NX vehicles requiring the following calibration please download both files at the same time, file 1 might not run on some vehicles requiring file 2 instead. First run file L-0087-25, if Error 001 comes up seconds after starting the reflash, run file L-0006-26 instead.

Model	Current Calibration IDs	<u>New</u> Calibration ID	File 1 Name - Size	File 2 Name - Size
NX	8679F7816101 8679F7824211	8679F7816301 8679F7824411	L-0087-25.cuw - 271MB	L-0006-26.cuw - 271MB

NOTICE:

If the Circumference Monitoring Camera Control Module has the **New** CIDs, no update is necessary.

2. REFLASH THE CIRCUMFERENCE MONITORING CAMERA CONTROL MODULE.

- a) Click “Yes” on the “Health Check Results” screen or follow the links on the table above to begin the reflash process.

NOTICE:

Reflash failure should be extremely rare and can be avoided by following all instructions and reprogramming best practices.

IX. COMPLETE REPAIR

1. DISCONNECT THE DCA-8000
2. RECONNECT THE ELECTRIC RADIATOR FAN (HYBRID VEHICLES)



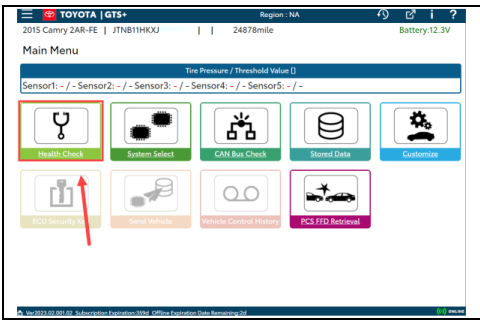

3. PERFORM VERIFICATION HEALTH CHECK

- Using a GTS+, click the “Health Check” button on the Main Menu.
- Clear DTC’s that may have set during the re-flash procedure.
- Re-run the Health Check to confirm that no DTC’s reappear.

Critical THIS VERIFICATION HEALTH CHECK IS **NECESSARY** to update the results and CIDs to the National database.

4. CONFIRM CID UPDATE

- On the Stored Data tab, confirm the following for the Circumference monitoring camera control module System:
 - The Calibration number has the “**New CID**” number.
 - The Update column says “**No**”.

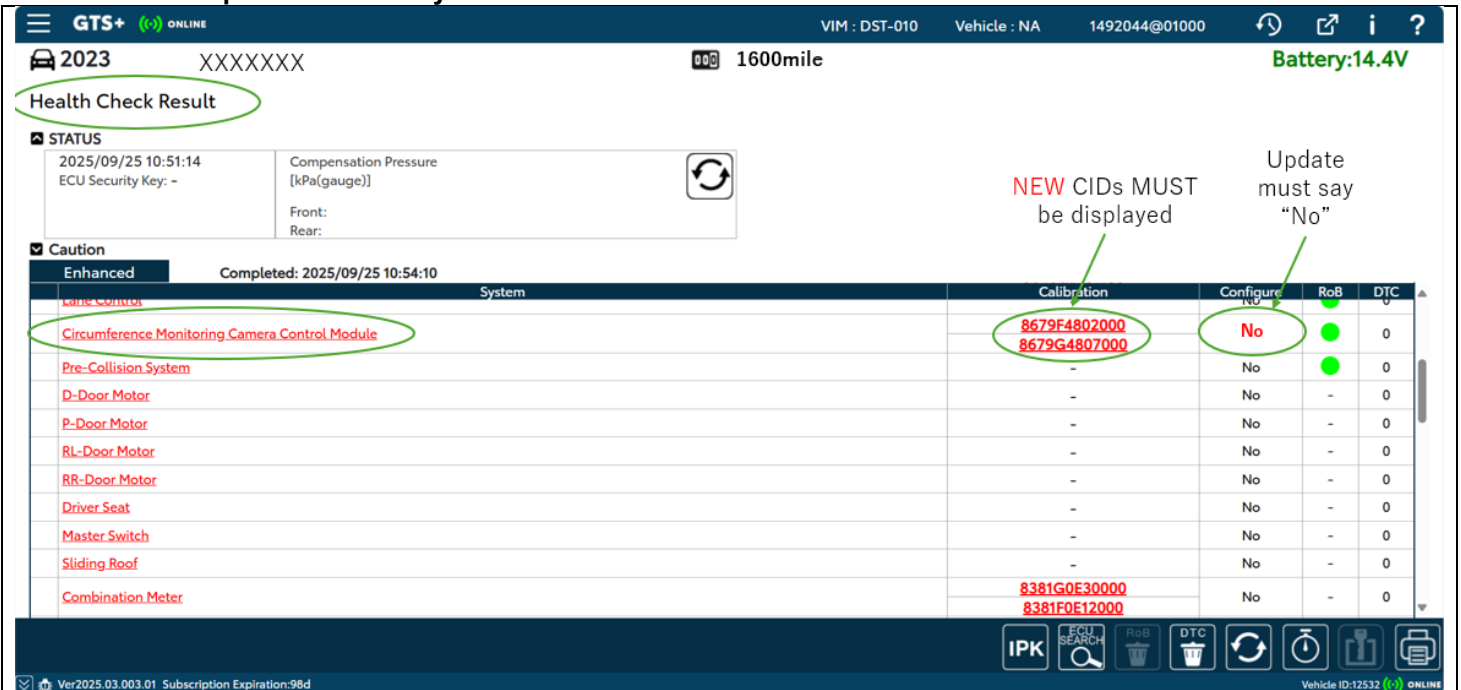

Critical Confirm the CIDs has been updated successfully to the **NEW CIDs** by someone other than the individual who performed the repair. Refer to page 5.

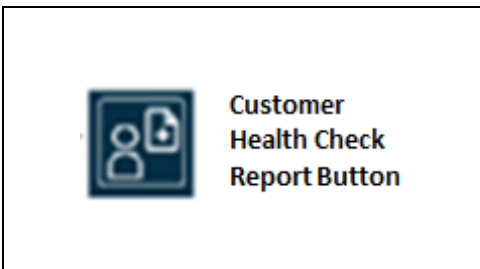

5. PRINT CUSTOMER HEALTH CHECK REPORT

- From the Stored Data tab, select the Customer Health Check Report button (TIS will launch when button is pressed).
- Log in to TIS.
- Input Vehicle Mileage and Repair Order number.
- Check the “Performed” campaign button for the applicable campaigns.
- Select the Report button.



Diagnostic Report

Vehicle Information

Mileage: 7787

Repair Order: 77888

Our systems show the following campaigns are outstanding. Have any of these campaigns been completed? (Check for SSC door label if unsure.)

XXX: Performed Not Performed

- f) Confirm Customer Health Check Report information is correct.
- g) Print Customer Health Check Report from TIS.
- h) Sign and provide to the customer.

◀ VERIFY REPAIR QUALITY ▶

- Confirm the reflash completes successfully.
- Confirm back up camera functions as designed
- Confirm there are no DTCs after the Calibration update.
- If you have any questions regarding this update, please contact your area representative.