

◀ IMPORTANT UPDATE ▶

The attached Technical Instructions have been updated. Refer to the details below.

DATE	TOPIC
11/26/2025	<ul style="list-style-type: none">Updated calibration Table to show download file name & size
12/11/2025	<ul style="list-style-type: none">Mirai CAL files available

The most recent update in the attached TI will be highlighted with a red box.

Please review this notification with your staff to assure that all relevant personnel have been briefed regarding this subject.

Thank you for your cooperation.

**TECHNICAL INSTRUCTIONS
FOR
SAFETY RECALL 25TA13
REPROGRAMMING FOR
CIRCUMFERENCE MONITORING CAMERA CONTROL MODULE**

**CERTAIN
bZ4X, CAMRY, CROWN, CROWN SIGNIA,
GRAND HIGHLANDER, HIGHLANDER,
LAND CRUISER, MIRAI, PRIUS, RAV4, SIENNA, VENZA,**

The repair quality of covered vehicles is extremely important to Toyota. All dealership technicians performing this recall are required to successfully complete the most current version of the E-learning course “Safety Recall and Service Campaign Essentials”. To ensure that all vehicles have the repair performed correctly; technicians performing this repair are required to currently have completed all of the following courses:

- **TIC206A – Electrical Repair 1**

It is the dealership’s responsibility to select technicians that have completed the above courses to perform this repair. Carefully review your resources, the technician skill level, and ability before assigning technicians to this repair. It is important to consider technician days off and vacation schedules to ensure there are properly trained technicians available to perform this repair at all times.

I. OPERATION FLOW CHART

The flow chart is for reference only. **DO NOT** use it in place of the full technical instructions. Follow **ALL** steps as outlined in the full technical instructions to confirm the campaign is completed correctly.

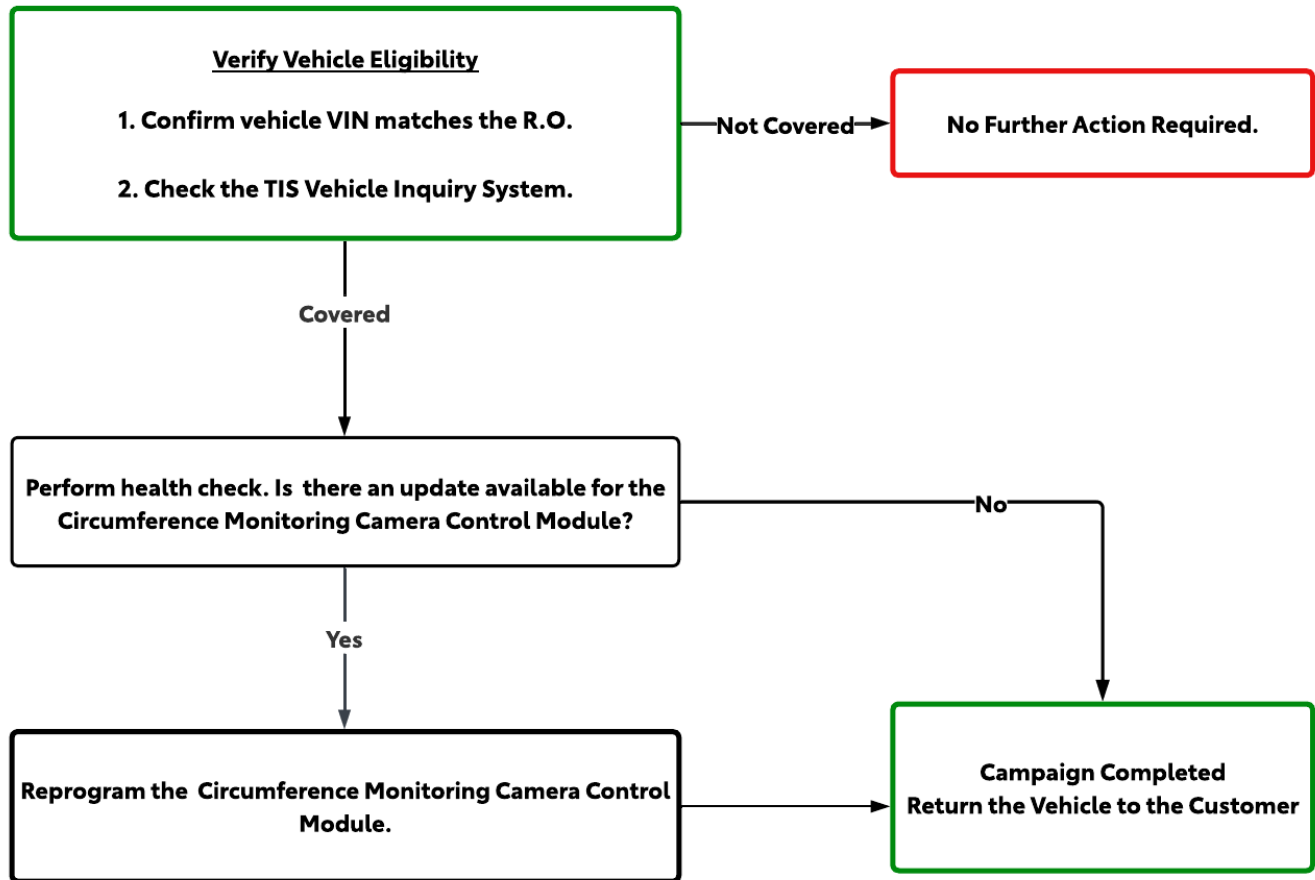

II. IDENTIFICATION OF AFFECTED VEHICLES

1. CHECK VEHICLE FOR CAMPAIGN ELIGIBILITY

- Compare the vehicle's VIN to the VIN listed on the Repair Order to ensure they match.
- Check the TIS Vehicle Inquiry System to confirm the VIN is involved in this Campaign, and that it has not already been completed.

HINT:

TMNA warranty will not reimburse dealers for repairs completed on vehicles that are not affected or were previously completed, even by another dealer.

III. PREPARATION

A. TOOLS & EQUIPMENT

- T-SB-0057-23
- DCA-8000 Battery Diagnostic Station
- GTS+

IV. BACKGROUND

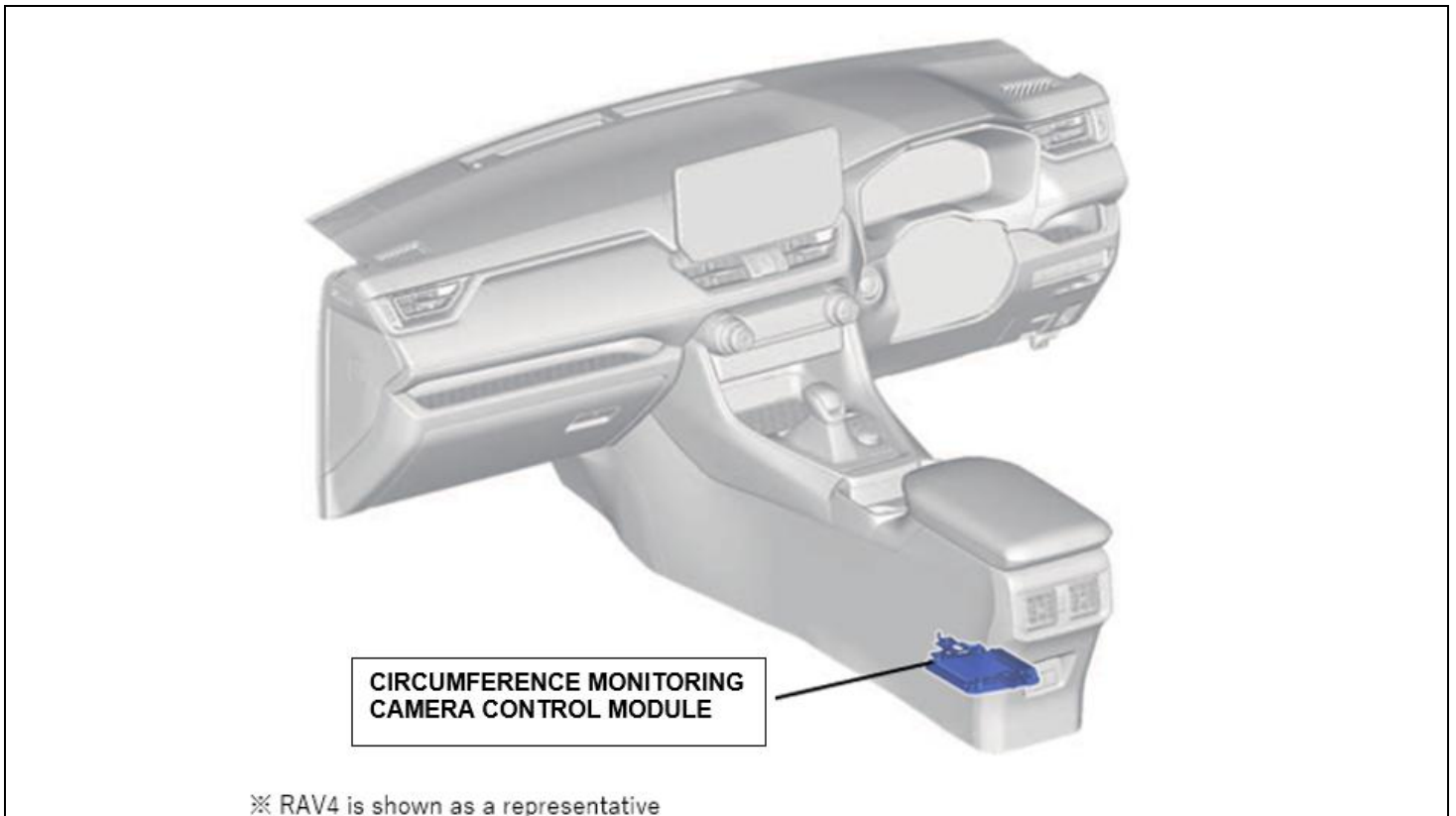

V. SAFETY PRECAUTIONS

Critical CRITICAL INFORMATION - READ THOROUGHLY

An ECU could be damaged if an error occurs in the communication while reprogramming the ECU. Confirm all work is performed as described in these instructions.

Be sure to connect the personal computer to an external AC power supply.

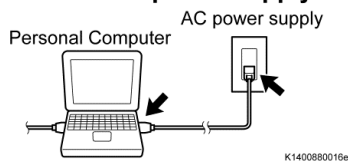

Turn off the screen saver and power saving mode.



- 1. STABILIZE THE POWER TO THE PERSONAL COMPUTER SIDE**
 - a) Be sure to connect the personal computer to an external AC power supply.

NOTICE:

The ECU could be damaged if the battery voltage of the personal computer drops while reprogramming.

- b) Turn off the screen saver and power saving mode of the personal computer so that the power to the hard disk is kept supplied.

NOTICE:

If the screen saver or power saving mode launches while reprogramming, the communication may be disconnected, resulting in the damage of the ECU.

DO NOT block the ventilation opening.



S220700139019aS

- c) **DO NOT** block the ventilation opening for the cooling fan of the personal computer.

NOTICE:

If the ventilation opening for the cooling fan is blocked with a sheet cover or the like, the personal computer may be heated excessively, causing the operation of the personal computer to stop.

Due to the stop of the operation, the communication for reprogramming signals could be stopped, resulting in the damage of the ECU.

VI. CIRCUMFERENCE MONITORING CAMERA CONTROL MODULE SYSTEM CALIBRATION ID VERIFICATION

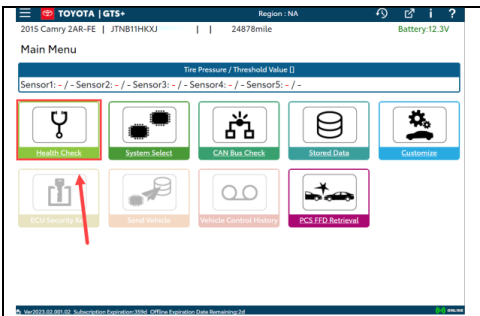

1. CHECK FOR DTC'S

- a) Using a GTS+, click the "Health Check" button on the Main Menu.

HINT:

This Campaign covers only the software update to the circumference monitoring camera control module System, as detailed in these instructions. It does not cover the diagnosis or replacement of any other systems on the vehicle.

2. CHECK CURRENT CALIBRATION

- a) Locate the "Update" column of the "Calibration Information" for the circumference monitoring camera control module system on the "Health Check Result" screen.
- b) Determine the status of an available update; indicated by a YES or NO.

HINT:

If the CIDs indicate 'Yes', proceed with the update procedure.

System	Calibration	Configure	RoB	DTC
Circumference Monitoring Camera Control Module	8679F4802000 8679G4807000	Yes	●	0
Pre-Collision System	-	No	●	0
D-Door Motor	-	No	-	0
P-Door Motor	-	No	-	0
RL-Door Motor	-	No	-	0
RR-Door Motor	-	No	-	0
Driver Seat	-	No	-	0
Master Switch	-	No	-	0
Sliding Roof	-	No	-	0
Combination Meter	8381G0E30000 8381F0E12000	No	-	0

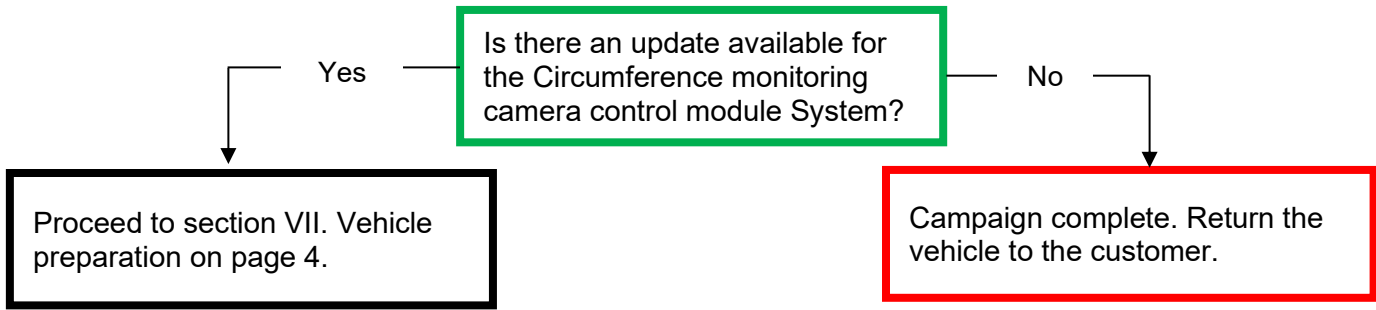

◀ **CRITICAL MESSAGE** ▶

It is critical that T-SB-0057-23 in addition to the Technical Instructions for this Recall [or LSC/CSC] are followed. This TSB outlines all steps necessary to prevent reprogramming failure. Toyota will not provide reimbursement coverage for reprogramming failures if this TSB is not followed. If you have a reprogramming failure that requires PARKING ASSIST COMPUTER replacement and the Technical Instructions and TSB were followed correctly, please create a case with the Technical Assistance Hotline documenting all information related to the failure. If sufficient reporting is received related to re-flash failure, there will be consideration for reimbursement.

VII. VEHICLE PREPERATION

1. VEHICLE PREPERATION

a) Confirm the following conditions:

- Vehicle in the IG position (READY OFF).
- Transaxle in Park.
- Parking brake engaged.
- Turn off all electrical accessories (i.e. climate control, audio system, etc.)
- Headlight switch in the DRL OFF position. (w/ DRL OFF position)
- Windshield wiper switch in the OFF position.

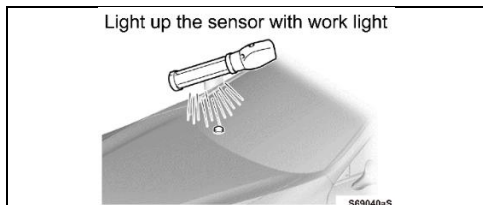

b) When the vehicle has no "OFF position" in the light control switch:

- 1) Turn the IG ON.
- 2) Set the light control switch to the AUTO position and make sure that the exterior lights are turned on.
- 3) Light up the automatic light control sensor with work light to keep the exterior lights turned off.

2. FOR HYBRID VEHICLES DISABLE THE ELECTRIC RADIATOR FAN BY UNPLUGGING THE CONNECTOR.

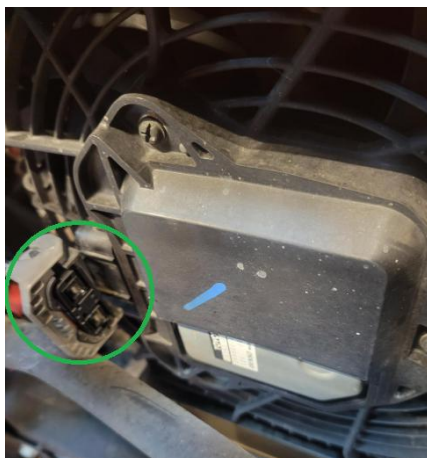

3. CONNECT THE 12V BATTERY TO A POWER SUPPLY. FOR

- a) Connect the DCA-8000 or other type of a power supply (not a battery charger) to the 12V battery.
- b) Tap the Reflash icon from the Main Menu screen of the DCA-8000.

Critical

A power supply MUST be used during reprogramming. ECU damage will occur if the battery voltage is not properly maintained during this re-flash procedure.

NOTICE:

A power supply must be connected directly to the 12V battery terminals and NOT the remote jump posts under the hood (if equipped).

4. VERIFY GTS+ SETUP

- a) Verify that the GTS+ meets the following conditions:
 - The latest version of software is loaded.
 - The GTS+ battery is fully charged. If not, connect the GTS+ to a 120V source.
 - The DLC III cable is in good condition.

Critical

The GTS+'s battery voltage must also be maintained during the re-flash procedure. If necessary, plug the GTS+ into a 120V outlet during this procedure.

NOTICE:

If the GTS+ communication with the vehicle fails during the re-flash procedure, the Circumference monitoring camera control module will be damaged.

VIII. UPDATE CALIBRATION

1. CONFIRM THE CALIBRATION ID

- a) Confirm the current calibration ID in the Circumference monitoring camera control module System.

System	Calibration	Configure	RoB	DTC
Circumference Monitoring Camera Control Module	8679F4802000 8679G4807000	Yes	●	0
Pre-Collision System	-	No	●	0
D-Door Motor	-	No	-	0
P-Door Motor	-	No	-	0
RL-Door Motor	-	No	-	0
RR-Door Motor	-	No	-	0
Driver Seat	-	No	-	0
Master Switch	-	No	-	0
Sliding Roof	-	No	-	0
Combination Meter	8381G0E30000 8381F0E12000	No	-	0

Please note that some vehicles might show up to 3 current calibration IDs but not all will get updated. The calibration IDs to re-flash in this campaign are as shown in the table below. Match as many Current CAL IDs from the vehicle to select the correct **New** CAL file from the table below. For vehicles that show more than one New CAL ID, only one file is required for the update.

Circumference Monitoring Camera Control Module System			
Model	Current Calibration IDs	New Calibration ID	File Name - Size
bZ4X	8679F4231013	8679F4231111	T-0071-25.cuw - 266MB
	8679F4230001 8679F4231012	8679F4230002 8679F4231111	T-0072-25.cuw - 272MB
	8679F4230001 8679F4231011	8679F4230002 8679F4231111	T-0073-25.cuw - 272MB
	8679G4202000	8679G4238000	T-0074-25.cuw - 266MB
	8679F4215000 8679G4225000	8679F4220000 8679G4234000	T-0075-25.cuw - 271MB
CAMRY	8679F3318000 8679G3318100	8679F3318100 8679G3318200	T-0076-25.cuw - 271MB
CROWN	8679F3052211	8679F3052311	T-0077-25.cuw - 271MB
	8679F3052111	8679F3052311	T-0078-25.cuw - 266MB
	8679F3052011	8679F3052311	T-0079-25.cuw - 266MB
	8679G3010100	8679G3019000	T-0080-25.cuw - 266MB
CROWN SIGNIA	8679G3008000	8679G3023000	T-0081-25.cuw - 266MB
GRAND HIGHLANDER	8679F4886001 8679F4886011	8679F4886101 8679F4886111	T-0082-25.cuw - 272MB
HIGHLANDER	8679F4889001 8679F4889011	8679F4889101 8679F4889211	T-0083-25.cuw - 272Mb
	8679F4889111	8679F4889211	T-0084-25.cuw - 266MB
	8679F4802000 8679G4806000	8679F4807000 8679G4825000	T-0085-25.cuw - 271MB
LAND CRUISER	8679G6010200	8679G6065000	T-0086-25.cuw - 266MB

PRIUS	8679G4702100	8679G4709000	T-0094-25.cuw - 266MB
	8679G4702000	8679G4709000	T-0095-25.cuw - 266MB
	8679G4703100	8679G4710000	T-0096-25.cuw - 266MB
	8679G4703000	8679G4710000	T-0097-25.cuw - 266MB
RAV4	8679G4212000	8679G4243000	T-0098-25.cuw - 266MB
	8679F4258011	8679F4258211	T-0099-25.cuw - 266MB
	8679F4258111	8679F4258311	T-0100-25.cuw - 266MB
	8679F4267011	8679F4267111	T-0101-25.cuw - 266MB
	8679F4268001 8679F4268011	8679F4268101 8679F4268111	T-0102-25.cuw - 271MB
	8679F4268001 8679F4269011	8679F4268101 8679F4269111	T-0103-25.cuw - 271MB
SIENNA	8679F4509001 8679F4509011	8679F4509101 8679F4509111	T-0104-25.cuw - 271MB
VENZA	8679F48A3011	8679F48A3111	T-0105-25.cuw - 266MB
MIRAI	8679F6208111	8679F6208211	T-0106-25.cuw - 266MB
	8679F6208011	8679F6208211	T-0107-25.cuw - 266MB
	8679F6212111	8679F6212211	T-0108-25.cuw - 266MB
	8679F6212011	8679F6212211	T-0109-25.cuw - 266MB
	8679G6202000	8679G6206000	T-0110-25.cuw - 266MB
	8679G6204000	8679G6211000	T-0111-25.cuw - 266MB

NOTICE:

If the Circumference Monitoring Camera Control Module has the **New CIDs**, no update is necessary.

2. REFLASH THE CIRCUMFERENCE MONITORING CAMERA CONTROL MODULE.

- a) Click “Yes” on the “Health Check Results” screen or follow the links on the table above to begin the reflash process.

NOTICE:

Reflash failure should be extremely rare and can be avoided by following all instructions and reprogramming best practices.

IX. COMPLETE REPAIR

1. DISCONNECT THE DCA-8000
2. RECONNECT THE ELECTRIC RADIATOR FAN (HYBRID VEHICLES)

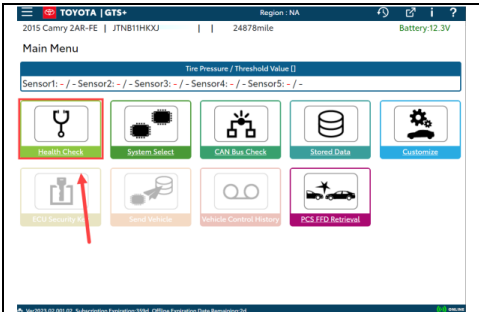
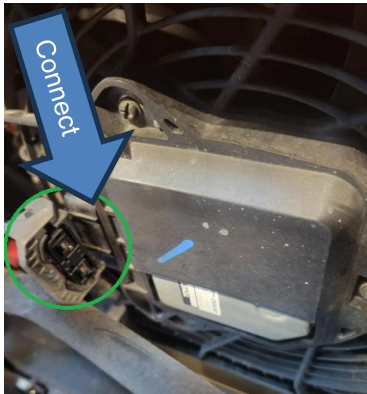

3. PERFORM VERIFICATION HEALTH CHECK

- a) Using a GTS+, click the “Health Check” button on the Main Menu.
- b) Clear DTC’s that may have set during the re-flash procedure.
- c) Re-run the Health Check to confirm that no DTC’s reappear.

Critical THIS VERIFICATION HEALTH CHECK IS NECESSARY to update the results and CIDs to the National database.

4. CONFIRM CID UPDATE

- a) On the Stored Data tab, confirm the following for the Circumference monitoring camera control module System:
 - The Calibration number has the “New CID” number.
 - The Update column says “No”.

GTS+ ONLINE VIM : DST-010 Vehicle : NA 1492044@01000 Battery:14.4V

2023 XXXXXXX 1600mile

Health Check Result

STATUS
2025/09/25 10:51:14
ECU Security Key: -

Compensation Pressure [kPa(gauge)]
Front:
Rear:

NEW CIDs MUST be displayed

Update must say "No"

System	Calibration	Configure	RoB	DTC
Lane Control				
Circumference Monitoring Camera Control Module	8679F4802000 8679G4807000	No	●	0
Pre-Collision System	-	No	●	0
D-Door Motor	-	No	-	0
P-Door Motor	-	No	-	0
RL-Door Motor	-	No	-	0
RR-Door Motor	-	No	-	0
Driver Seat	-	No	-	0
Master Switch	-	No	-	0
Sliding Roof	-	No	-	0
Combination Meter	8381G0E30000 8381F0E12000	No	-	0

Ver2025.03.003.01 Subscription Expiration:98d Vehicle ID:12532 ONLINE

Critical Confirm the CIDs has been updated successfully to the **NEW CIDs** by someone other than the individual who performed the repair. Refer to page 5.



- 5. PRINT CUSTOMER HEALTH CHECK REPORT**
- From the Stored Data tab, select the Customer Health Check Report button (TIS will launch when button is pressed).
 - Log in to TIS.
 - Input Vehicle Mileage and Repair Order number.
 - Check the "Performed" campaign button for the applicable campaigns.
 - Select the Report button.

Toyota | Lexus

Diagnostic Report

Vehicle Information

Mileage: 7787

Repair Order: 77888

Our systems show the following campaigns are outstanding. Have any of these campaigns been completed? (Check for SSC door label if unsure.)

XXX: Performed Not Performed

Report

- Confirm Customer Health Check Report information is correct.
- Print Customer Health Check Report from TIS.
- Sign and provide to the customer.

◀ VERIFY REPAIR QUALITY ▶

- **Confirm the reflash completes successfully.**
- **Confirm back up camera functions as designed**
- **Confirm there are no DTCs after the Calibration update.**
- **If you have any questions regarding this update, please contact your area representative.**