



VOLUNTARY RECALL CAMPAIGN

Classification: EC25-014	Reference: NTB25-056	Date: December 1, 2025
-----------------------------	-------------------------	---------------------------

VOLUNTARY SAFETY RECALL CAMPAIGN 2013-2021 NV200, 2014-2017 AND 2019 NV200 TAXI; FUEL TANK TEMPERATURE SENSOR

CAMPAIGN ID #: PMA56
APPLIED VEHICLES: 2013-2021 NV200 (M20)
2014-2017, and 2019 NV200 Taxi (M30)

**Check Service COMM or Dealer Business Systems (DBS)
National Service History to confirm campaign eligibility.**

INTRODUCTION

Nissan is conducting this voluntary safety recall campaign on certain specific model year 2013-2021 NV200, 2014-2017 and 2019 NV200 Taxi vehicles to re-route the fuel level and fuel tank temperature sensor harness and, if necessary, replace the fuel level and fuel tank temperature sensor. This service will be performed at no charge to the customer for parts or labor.

IDENTIFICATION NUMBER

Nissan has assigned identification number PMA56 to this campaign. This number must appear on all communication and documentation of any nature dealing with this campaign.

DEALER RESPONSIBILITY

It is the dealer’s responsibility to check Service COMM or Dealer Business Systems (DBS) National Service History for the campaign status on each vehicle falling within the range of this voluntary safety recall which for any reason enters the service department. This includes vehicles purchased from private parties or presented by transient (tourist) owners and vehicles in a dealer’s inventory. **Federal law requires that new vehicles in dealer inventory which are the subject of a safety recall must be corrected prior to sale. Failure to do so can result in civil penalties by the National Highway Traffic Safety Administration.** While federal law applies only to new vehicles, Nissan strongly encourages dealers to correct any used vehicles in their inventory before they are retailed.

Bulletins are intended for use by qualified technicians, not 'do-it-yourselfers'. Qualified technicians are properly trained individuals who have the equipment, tools, safety instruction, and know-how to do a job properly and safely. **NOTE:** If you believe that a described condition may apply to a particular vehicle, DO NOT assume that it does. See your Nissan dealer to determine if this applies to your vehicle.

IMPORTANT:

Attention California Dealers

An Emission Recall Campaign Completion (ERCC) label must be filled out by the technician performing the repair, and then attached to the underside of the vehicle hood. A sample of the label is shown in Figure 1.

<p>Technician to fill in the following: "Re-routed fuel level and fuel tank temperature sensor harness" OR "Replaced fuel level and fuel tank temperature sensor and re-routed fuel level and fuel tank temperature sensor harness" per Campaign ID # PMA56"</p>	<p>NISSAN MOTOR CORPORATION AUTHORIZED MODIFICATIONS THE FOLLOWING MODIFICATIONS HAVE BEEN MADE:</p> <p>THESE MODIFICATIONS HAVE BEEN APPROVED AS APPROPRIATE BY EPA AND CARB</p>
<p>Also fill in the following: "DEALER CODE" and "DATE" Put "ARB/EPA" under "CHANGE AUTHORITY"</p>	
<p>DEALER CODE: _____ DATE: _____ CHANGE AUTHORITY: _____</p>	

Figure 1

California law prohibits owners from renewing their California registration if emissions related recall work has not been performed. California dealers are required to issue a proof of correction certificate to vehicle owners upon completion of emissions related recall work. Please fill out one of the campaign completion forms for each owner that has this campaign performed. Instruct owners to keep this certificate unless they are requested to mail it to the DMV. A sample of the form is shown in Figure 2.

Vehicle Emission Recall - Proof of Correction				
License Number	Make	Model Year	Body Type	Vehicle Identification Number <input type="text"/> <input type="text"/> <input type="text"/> <input type="text"/> <input type="text"/> <input type="text"/> <input type="text"/> <input type="text"/> <input type="text"/> <input type="text"/> <input type="text"/> <input type="text"/> <input type="text"/> <input type="text"/> <input type="text"/> <input type="text"/> <input type="text"/> <input type="text"/> <input type="text"/> <input type="text"/> <input type="text"/> <input type="text"/>
Manufacturer _____		Recall Number _____		
The above described vehicle has been repaired, modified and/or equipped with new emission control devices to meet applicable California Emission Control Laws.				
Dealer's Name _____		Address, City, State, Zip _____		
Date _____	Dealership's Authorized Signature X _____			
Return this certificate to DMV <u>only</u> when required - otherwise retain for your records.				
CAEMRC 1-20				

Figure 2

HINT:

- These forms (item number **CAEMRC 1-20**) and labels (item number **NIS-UHL-16**) are available from Nissan Publications through NNAnet at no charge.
- When either item (form or label) is ordered, you will automatically receive the other item as well.

SERVICE PROCEDURE

⚠ WARNING

To avoid the risk of death or severe personal injury, adhere to the following when servicing the fuel system:

- Place a CAUTION: FLAMMABLE sign in the work area.
- Be sure to work in a well-ventilated area and furnish workshop with a CO2 fire extinguisher.
- Do not smoke while servicing fuel system. Keep open flames and sparks away from the work area.
- Quick connector can be removed when the tabs are completely depressed. Do not twist it more than necessary.
- Do not use any tools to disconnect quick connector.
- Keep resin tube away from heat. Be especially careful when welding near the resin tube.
- Prevent acid liquid such as battery electrolyte, etc. from getting on resin tube.
- Do not bend or twist resin tube during installation and disconnection.
- To keep the connecting portion clean and to avoid damage and foreign materials, cover them completely with plastic bags (A) or something similar (Figure 3).
- To avoid damage to the O-ring in the quick connector, do not insert a plug into the quick connector.

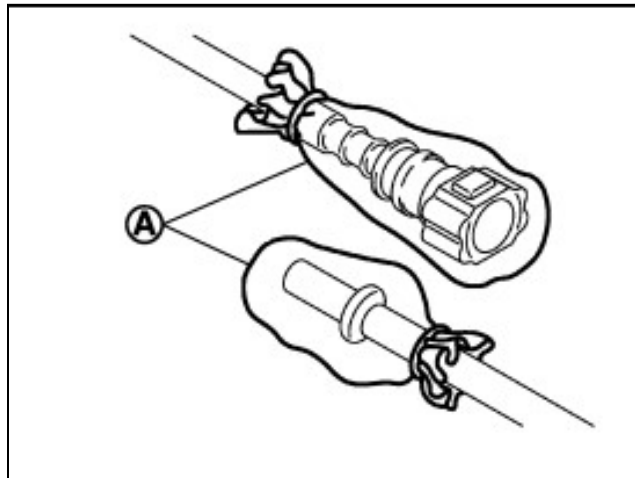

Figure 3

1. Connect the Vehicle Interface (VI) to the Data Link Connector (DLC).
2. Turn the ignition ON engine OFF.
3. Start C-III plus on the CONSULT PC.
4. Select **Diagnosis (All Systems)**.
5. Check for DTCs.
 - If **NONE** of the DTCs listed in **Table A** are stored, reroute the fuel level sensor/fuel tank temperature sensor wiring harness. Continue to step 6. **Do NOT replace the fuel level sensor/fuel tank temperature sensor.**
 - If **ONE OR MORE** of the DTCs listed in **Table A** are stored in the engine (Past or Current), replace the fuel level sensor/fuel tank temperature sensor **AND** route the fuel level sensor/fuel tank temperature sensor wiring harness as described in this procedure. Continue to step 6.

HINT: If any DTCs are stored (other than P0181, P0182, P0183), they are not covered under this action. Refer to the ESM for further diagnostic information.

Table A

DTC	DESCRIPTION
P0181	FTT SENSOR (Fuel temperature sensor "A" circuit range/performance)
P0182	FTT SEN/CIRCUIT (Fuel temperature sensor "A" circuit high)
P0183	FTT SEN/CIRCUIT (Fuel temperature sensor "A" circuit low)

6. Erase DTCs if they are present, and then continue to step 7 for fuel level sensor unit, fuel filter and fuel pump assembly (fuel pump module) removal.
7. Remove the fuel level sensor unit, fuel filter and fuel pump assembly (fuel pump module) from the fuel tank and place it on a clean work surface.
 - Refer to the ESM: **ENGINE > FUEL SYSTEM > MR20 > REMOVAL AND INSTALLATION > FUEL LEVEL SENSOR UNIT, FUEL FILTER AND FUEL PUMP ASSEMBLY > Removal and Installation**
 - On **APPLIED VEHICLES** that do **not** have access to the fuel pump inspection hole cover, remove the fuel tank assembly to access the fuel pump module.
 - Refer to the ESM: **ENGINE > FUEL SYSTEM > MR20 > REMOVAL AND INSTALLATION > FUEL TANK > Removal and Installation**

Sensor Harness Routing

HINT:

- The fuel level sensor/fuel tank temperature sensor wiring harness in the following figures has been painted to highlight the correct routing.
- A video is available on ASIST to help with the fuel level sensor/fuel tank temperature sensor wiring harness routing.

8. Remove the fuel tank temperature (FTT) sensor from the retaining clip on the fuel pump module.

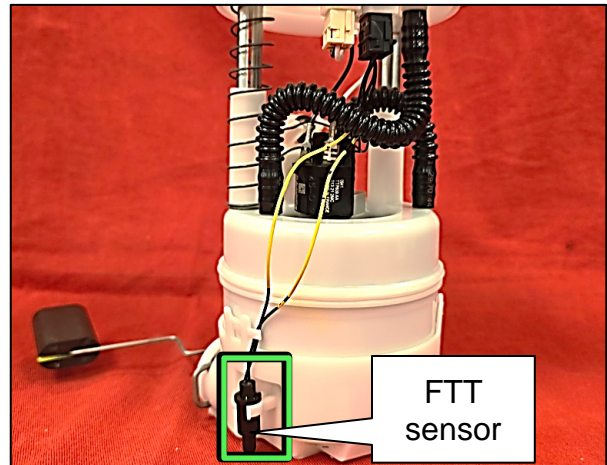

Figure 4

9. Disconnect the black fuel level sensor and FTT sensor wiring harness connector from the fuel pump module.

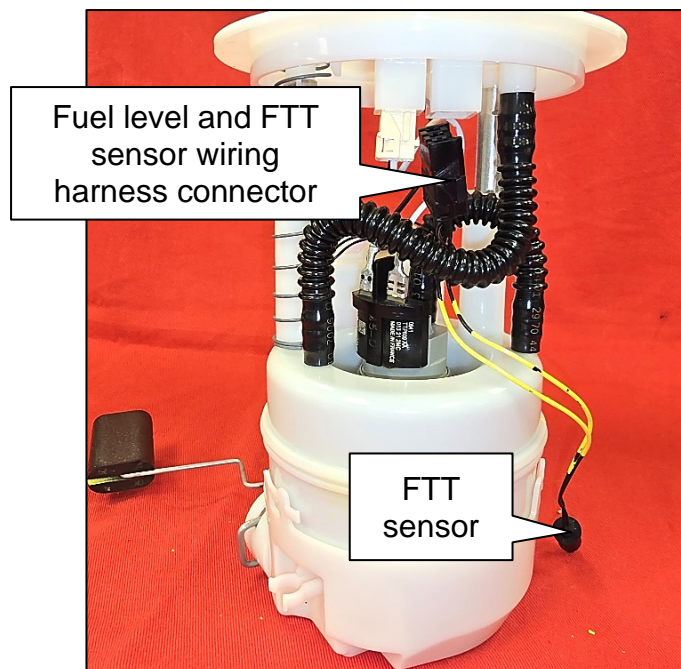

Figure 5

- Carefully pull the fuel level and FTT sensor wiring harness from the fuel pump module.

IMPORTANT: If one or more of the DTCs listed in **Table A** were present in step 5 on page 4, replace the fuel level sensor/FTT sensor assembly and continue to step 11 to reroute the fuel level sensor/FTT sensor wiring harness.

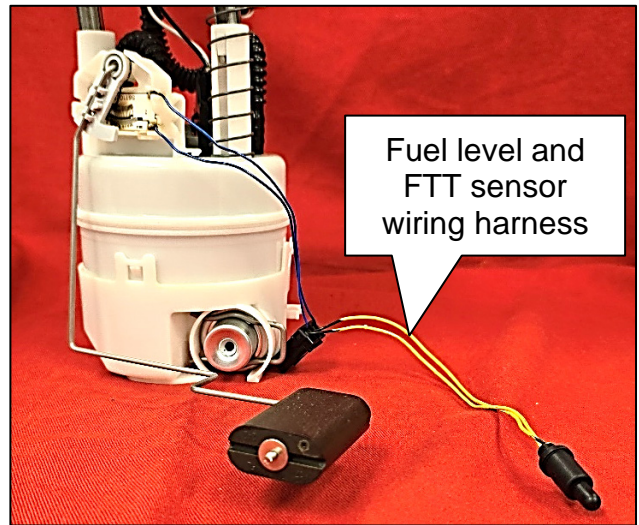

Figure 6

- With the fuel level sensor facing toward you, route the FTT sensor between the right hand black corrugated hose and the fuel pump as shown in Figure 7.

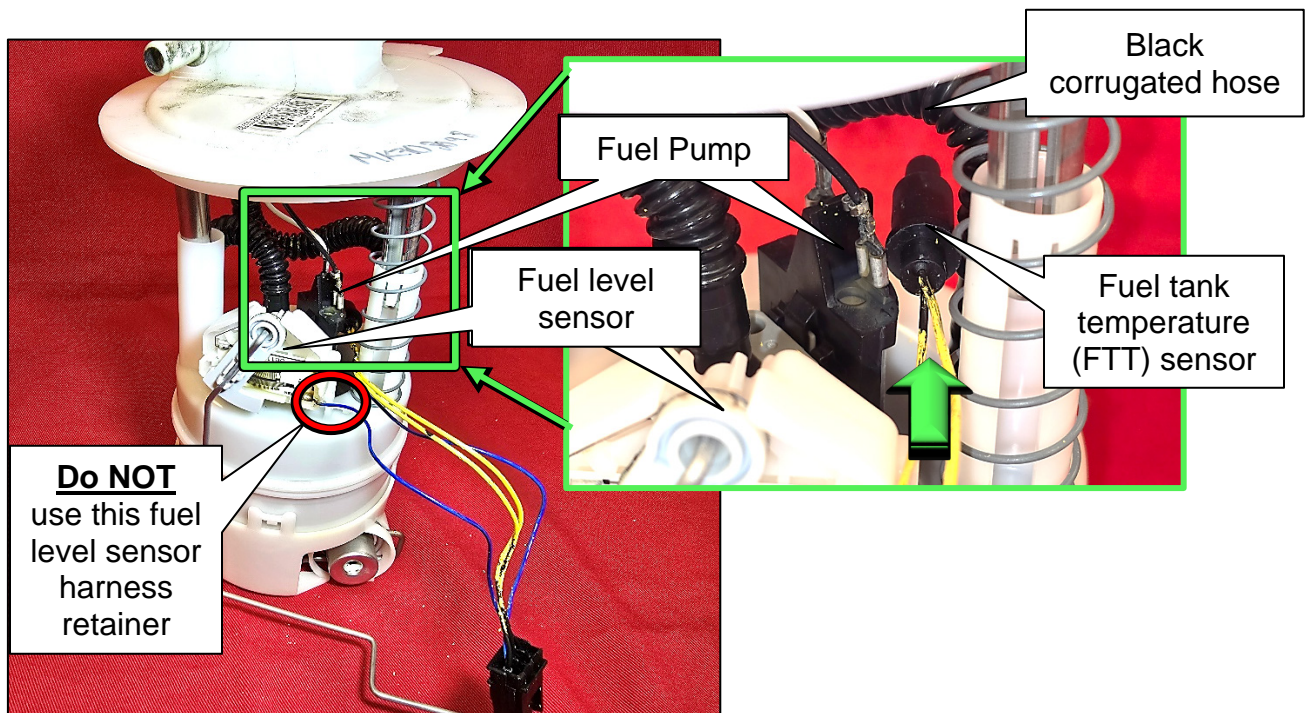

Figure 7

IMPORTANT: **Do NOT** clip the fuel level sensor wires into the harness retainer beside the fuel level sensor shown in Figure 7.

12. Rotate the fuel pump assembly 180° and carefully pull the remainder of the wiring and electrical connector between the fuel pump and black corrugated hose.

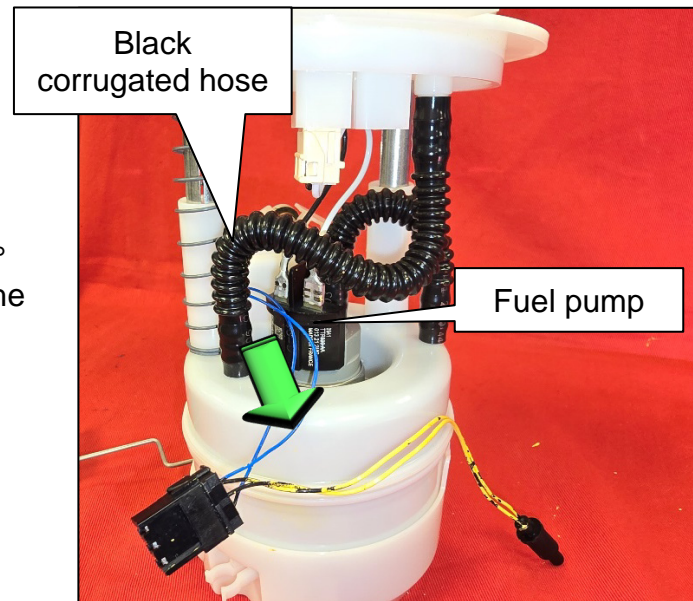

Figure 8

13. Reconnect the black fuel level sensor and FTT sensor wiring harness connector into the fuel pump module as shown in Figure 9.
14. Wrap the FTT sensor with wiring around the fuel level sensor wires clockwise two (2) times (this will keep the fuel level sensor/FTT sensor wiring harness away from the fuel pump terminals).

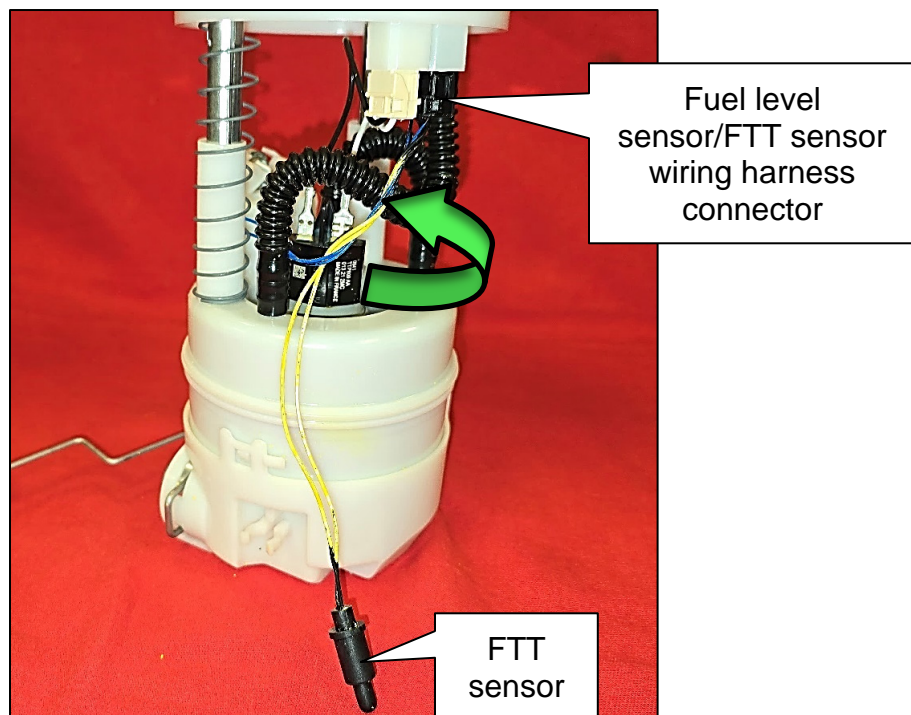

Figure 9

15. Place the FTT sensor wiring harness into the wire retainer and then install the FTT sensor into the retaining clip as shown in Figure 10.

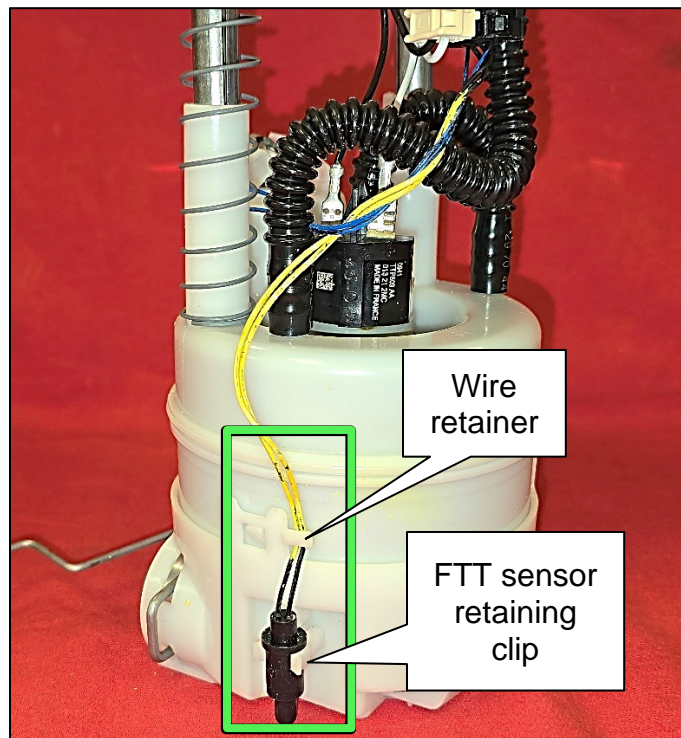

Figure 10

⚠ WARNING

To avoid the risk of death or severe personal injury:

- **Do not reuse the O-ring**
- **Do not bend the float arm during installation**

16. Reinstall the fuel pump module into the fuel tank.
 - Refer to the ESM: **ENGINE > FUEL SYSTEM > MR20 > REMOVAL AND INSTALLATION > FUEL LEVEL SENSOR UNIT, FUEL FILTER AND FUEL PUMP ASSEMBLY > Removal and Installation**
17. Reinstall the fuel tank assembly if removed for access to the fuel pump module.
 - Refer to the ESM: **ENGINE > FUEL SYSTEM > MR20 > REMOVAL AND INSTALLATION > FUEL TANK > Removal and Installation**

PARTS INFORMATION

DESCRIPTION	PART NUMBER	QUANTITY
PACKING-FUEL GAUGE	17342-1HJ0A	1
SENDER UNIT-FUEL GAUGE	25060-9SM0A	1 (If needed)

CLAIMS INFORMATION

Submit a "CM" line claim using the following claims coding:

CAMPAIGN ("CM") ID	DESCRIPTION	OP CODE	FRT
PMA56	No DTCs, Re-route fuel level and FTT sensor wiring harness using inspection hole cover	PMA560	0.7
	No DTCs, Remove fuel tank, Remove fuel pump module, Re-route fuel level and FTT sensor wiring harness	PMA561	1.2
	DTC stored, Remove fuel pump module using inspection hole cover, Replace fuel level and FTT sensor and Re-route wiring harness	PMA562	0.8
	DTC stored, Remove fuel tank, Remove fuel pump module, Replace fuel level and FTT sensor and Re-route wiring harness	PMA563	1.3

AMENDMENT HISTORY

PUBLISHED DATE	REFERENCE	DESCRIPTION
December 1, 2025	NTB25-056	Original bulletin published