

◀ IMPORTANT UPDATE ▶

The attached Technical Instructions have been updated. Refer to the details below.

DATE	TOPIC
4/7/2026	<ul style="list-style-type: none">Added notes for removal and installation of seat rails.

The most recent update in the attached Technical Instructions will be highlighted with a red box.

Please review this notification with your staff to assure that all relevant personnel have been briefed regarding this subject.

Thank you for your cooperation.

TECHNICAL INSTRUCTIONS

FOR

SAFETY RECALL 25TA12

SECOND ROW SEAT RAIL REPLACEMENT

CERTAIN 7 PASSENGER 2025 MODEL YEAR SIENNA

The repair quality of covered vehicles is extremely important to Toyota. All dealership technicians performing this recall are required to successfully complete the most current version of the E-Learning course “Safety Recall and Service Campaign Essentials”. To ensure that all vehicles have the repair performed correctly; technicians performing this repair are required to currently have completed the following course:

-TIC206B Electrical Repair 2

It is the dealership’s responsibility to select technicians that have completed the above course to perform this repair. Carefully review your resources, the technician skill level, and ability before assigning technicians to this repair. It is important to consider technician days off and vacation schedules to ensure there are properly trained technicians available to perform this repair at all times.

I. OPERATION FLOW CHART

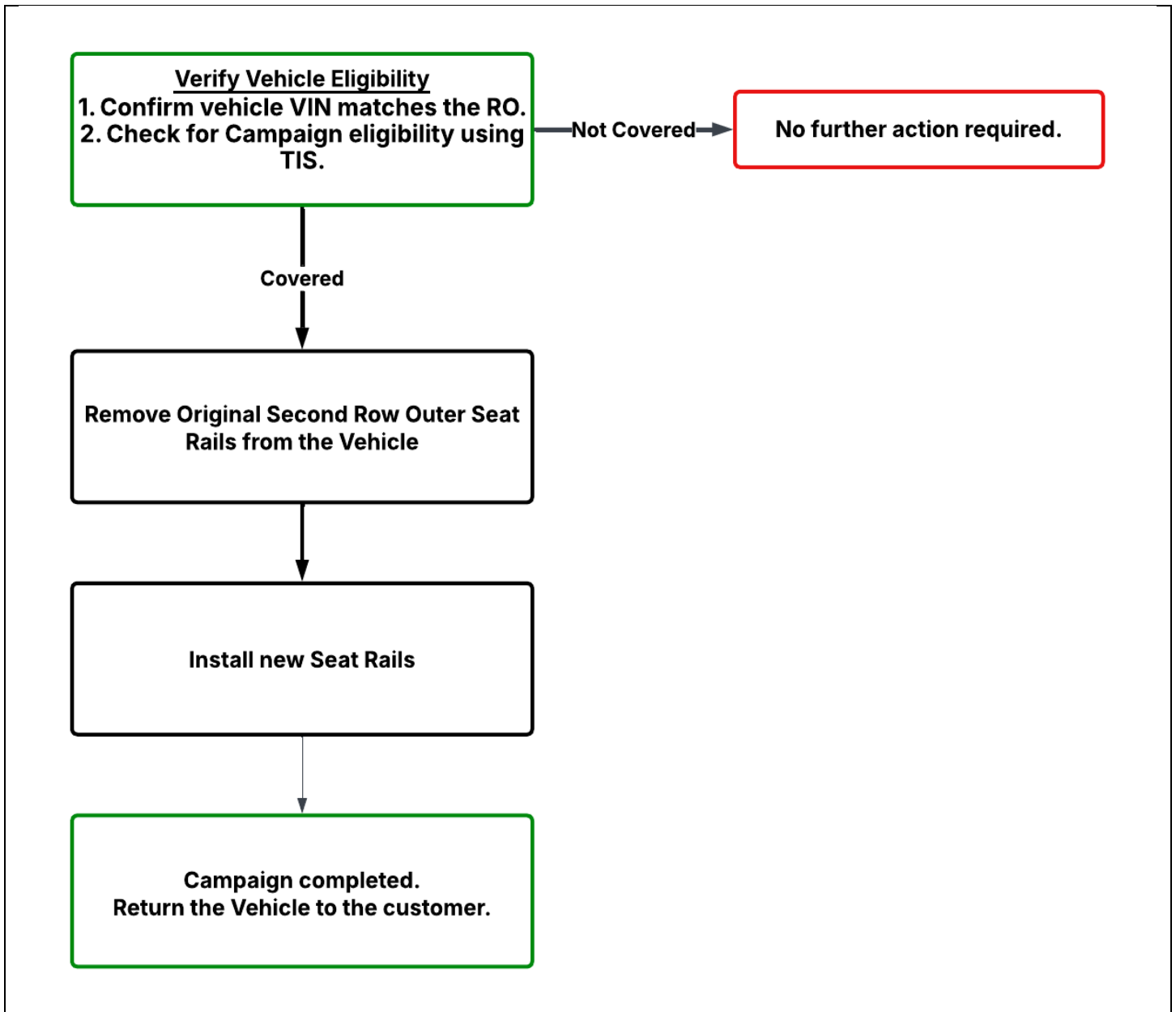

II. IDENTIFICATION OF AFFECTED VEHICLES

1. CHECK VEHICLE FOR CAMPAIGN ELIGIBILITY

- Compare the vehicle's VIN to the VIN listed on the Repair Order to ensure they match.
- Check the TIS Vehicle Inquiry System to confirm the VIN is involved in this Campaign, and that it has not already been completed.

Note: TMNA warranty will not reimburse dealers for repairs completed on vehicles that are not affected or were previously completed, even by another dealer.

III. PREPARATION

A. PARTS

Part Number	Part Description	Quantity
04005-41108	TRACK ASSY, RR SEAT, OUTER SET	1

Part Number	Part Description	Quantity
72170-08110	TRACK ASSY, RR SEAT, OUTER LH	1
72160-08120	TRACK ASSY, RR SEAT, OUTER RH	1

*The kit above includes the following parts:

B. TOOLS & EQUIPMENT

• Techstream	• Standard Hand Tools	• Torque Wrench
--------------	-----------------------	-----------------

IV. BACKGROUND

The subject vehicles contain second-row seats that are mounted on seat rails that may have been improperly welded

Second Row Seat Rails (7 Passenger configuration)

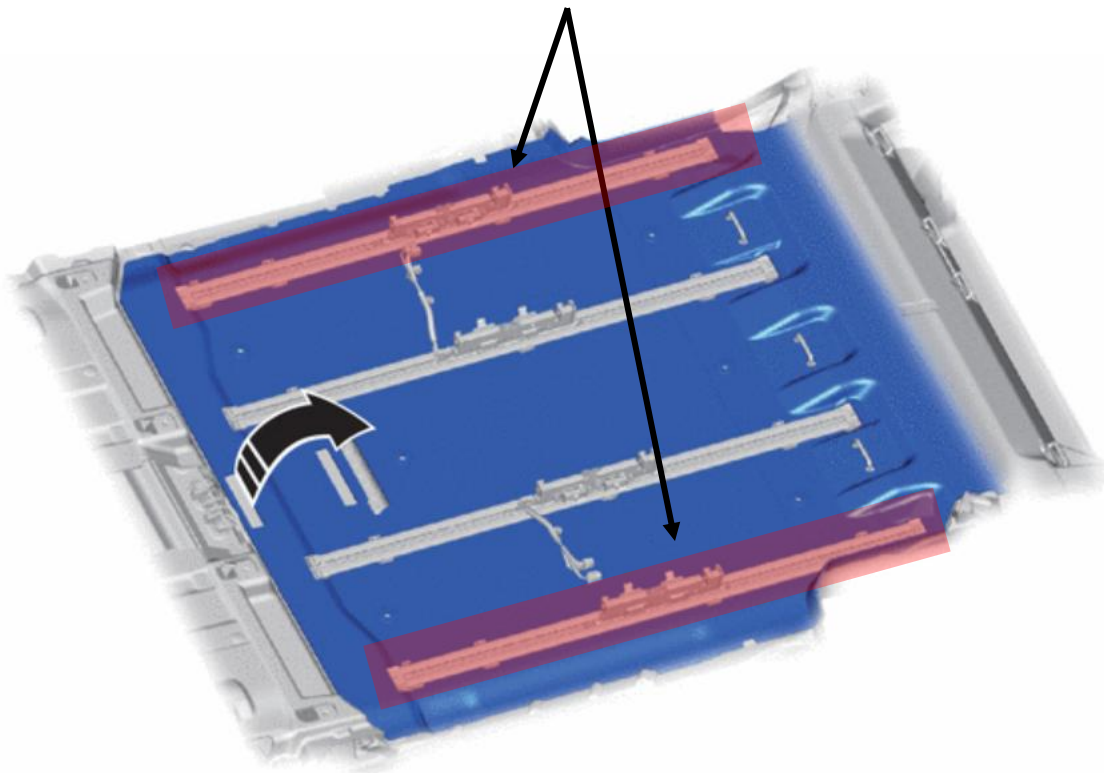

V. WORK PROCEDURE



1. PREPARE INTERIOR FOR REPAIR

- a. Adjust the front seats to their forward-most positions.
- b. Adjust the recline setting to its upward position.
- c. Install fender covers onto the sliding door entrances.
- d. Stage a moving blanket to place removed seats and interior panels.
- e. Stow away the 3rd row seats



2. REMOVE THE DRIVER AND PASSENGER SIDE 2ND ROW SEATS REAR BOLTS

- a. Adjust the driver and passenger side 2nd-row seats to their forward-most position.
- b. Open the (2) passenger side rear bolt access covers.
- c. Repeat for driver's side.

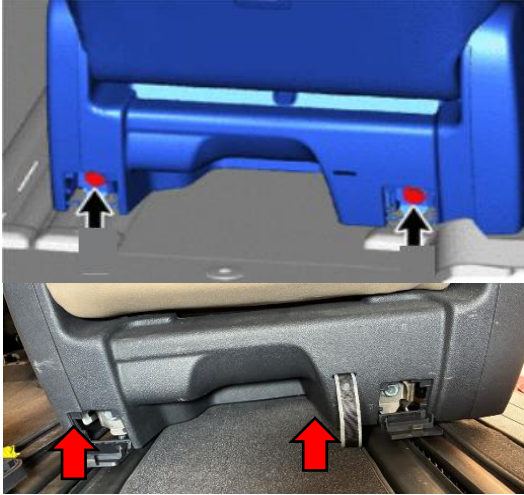

- d. Remove the (2) bolts on the rear side of the passenger side rear No. 1 seat assembly.
- e. Repeat for driver's side.



- f. Slide the 2nd row passenger seat to its rear-most position.
- g. Repeat for driver's side



- h. Remove the seat cushion lower shield by pulling forward to disengage the clips.
- i. Repeat for driver's side.

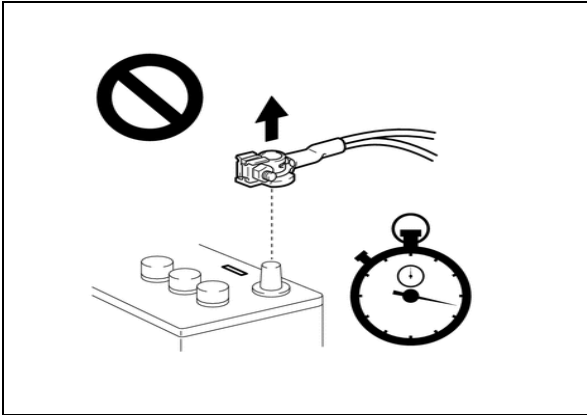

2. REMOVE THE NEGATIVE BATTERY TERMINAL.

- a. Remove the negative battery terminal and wait at least 60 seconds after disconnecting the cable from the negative (-) terminal before disconnecting any airbag connectors.

3. DISCONNECT THE WIRING HARNESS & REMOVE SEATS

- a. Push down the release button and slide the sides of the connector in the direction shown by the arrows in the illustration below. (At this time, the connector cannot be disconnected yet.)

HINT: Check that the position of the release button is as shown in the illustration below.

- b. Push down the release button and slide the connector again to disconnect the airbag connector.

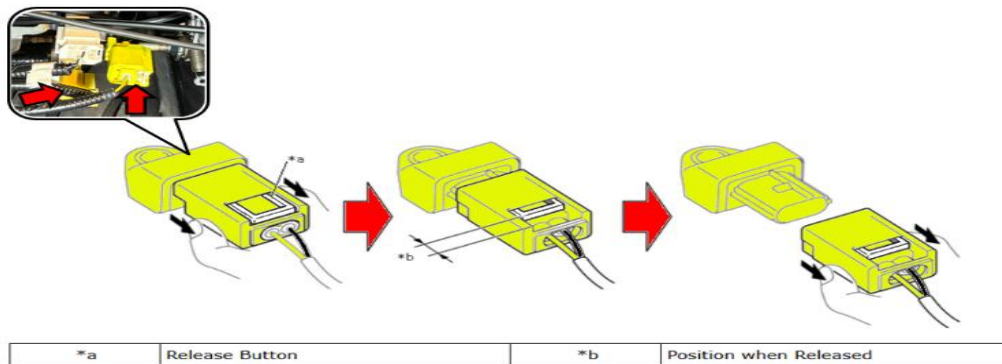

NOTE:

- When disconnecting any airbag connector, take care not to damage the airbag wire harness.
- Pushing down on the top of the connector will prevent the lock from being released, so hold the sides of the connector.

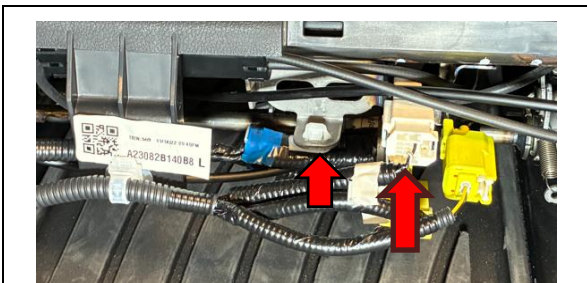

- c. Disconnect the white connector.
- d. Detach the harness clip from the seat assembly.
- e. Repeat for driver's side.

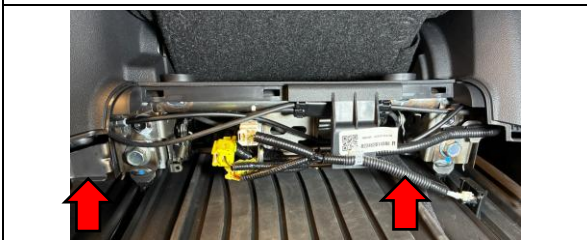

- f. Remove the (2) bolts on the front side of the passenger side rear No. 1 seat assembly.
- g. Repeat for driver's side.

NOTE: Be sure not to damage the airbag connector or harness when removing the seat bolt.

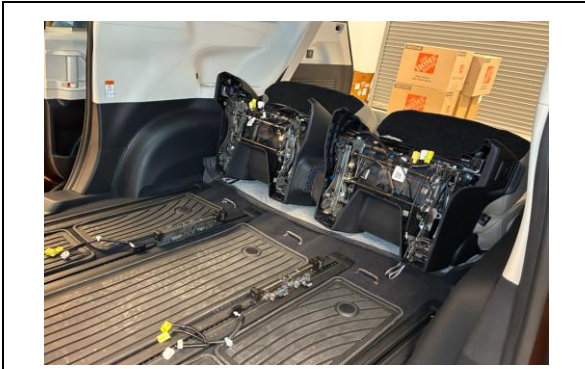

- h. Remove the driver's and passenger side rear No. 1 seat assemblies from their rails, lean them back, and temporarily store them in the cargo area.

NOTE:

- Be sure that the airbag wire harness has been cleared from the seat assembly before attempting to remove the seat.
- Be careful not to damage the vehicle body.

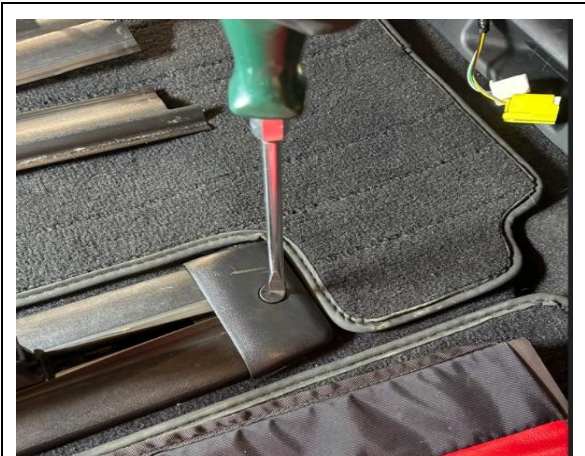

5. REPLACE THE DRIVER SIDE AND PASSENGER SIDE OUTBOARD SEAT TRACK LOWER RAILS

- a. Remove the (2) driver side floor carpet mouldings.
- b. Repeat process for passenger side.



- c. Remove the (2) driver side seat track lower rail outer protectors.
- d. Pull up from the inside, beginning at the front, and slowly work your way to the rear to remove the protector.
- e. Repeat process for passenger side.



NOTE: Keep these organized by rail in a safe location, as they will be reinstalled in a later step.

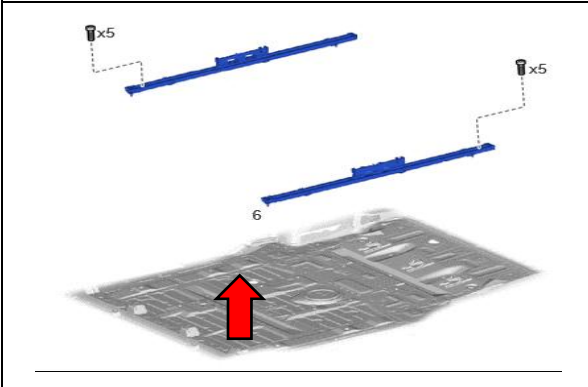

- f. Slide the rail so that its position allows for access to all 5 bolts.
- g. Using a T50 "TORX" socket and hand ratchet, remove the driver side outboard seat track lower rail assembly bolts, then remove the rail assembly from the vehicle.
NOTE: "T50 TORX" bolts must be removed by hand to avoid damage to the cage holding the nut under the floor.
- h. Using a paint marker, mark it with an "X".
- i. Repeat the process for the passenger side outboard rail assembly.

- j. Install the **NEW** driver's side outboard seat track lower rail assembly.
- k. Slide the rails so that all bolt holes are accessible.
- l. Hand-tighten the bolts.

Note: Do not use an impact wrench while tightening the rail bolts as this will result in damage to the nut cage under the floor.

- m. Torque the bolts in sequence, starting from the front, working towards the rear.
- n. Repeat the process for the **NEW** passenger side outboard seat track lower rail assembly.

Torque:
39 N·m {29 ft·lbf}

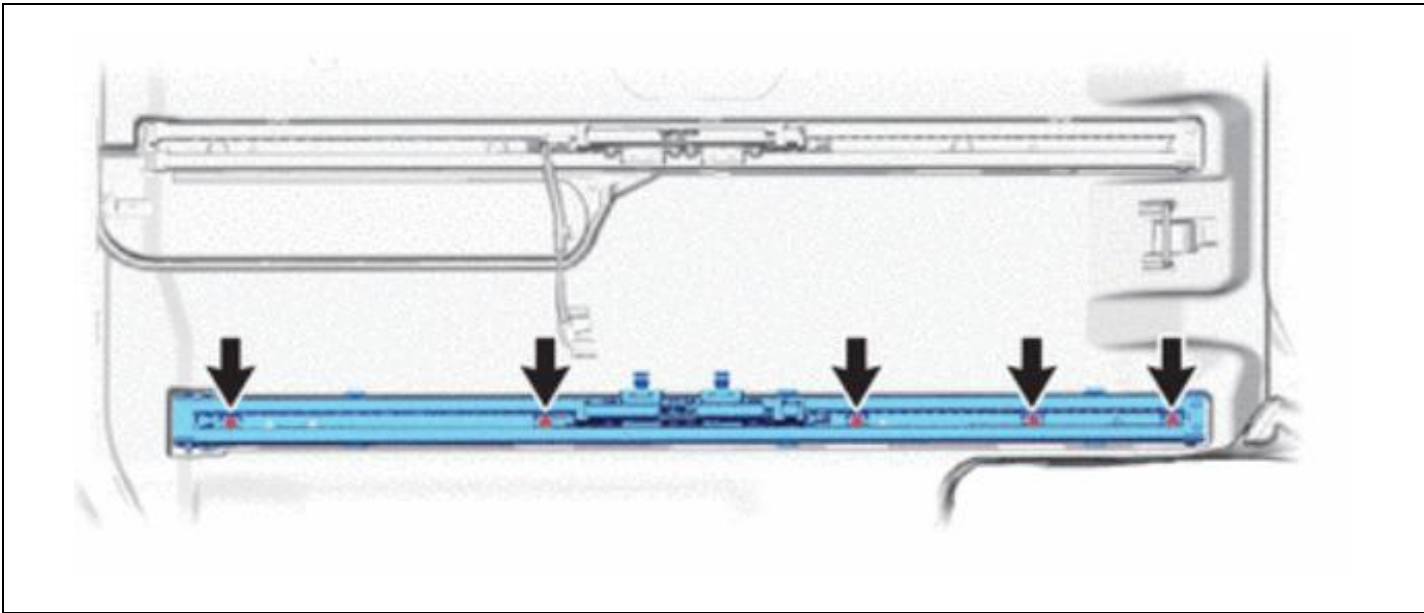

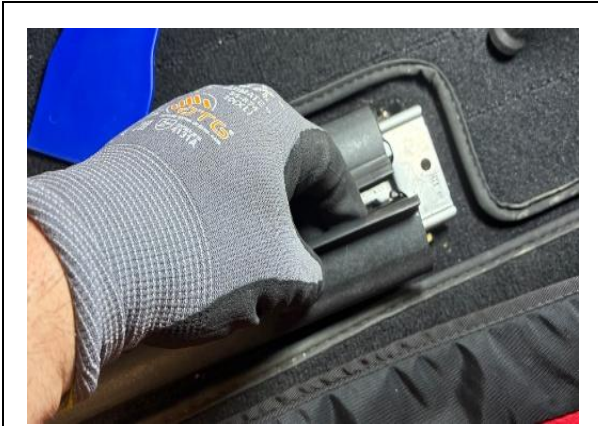

6. REINSTALL THE SEAT TRACK LOWER RAIL OUTER PROTECTORS

- a. Reinstall all (4) seat track lower rail outer protectors.
- b. Install by pressing firmly, starting from the front, working towards the rear.



7. REINSTALL THE FLOOR CARPET MOULDINGS

- a. Reinstall all (4) floor carpet moldings.



8. REINSTALL 2ND ROW SEATS

- a. Prepare by making sure that all (4) seat track rails are locked in place in parallel with each other.



- b. Install the passenger side rear No. 1 seat assembly onto the rails.
- c. Repeat for driver's side

NOTE: Be sure that the airbag wire harness has been cleared from the seat assembly before attempting to reinstall the seat.

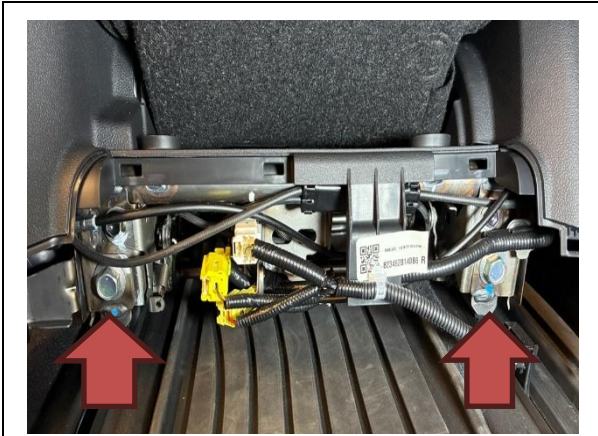

- d. Hand - tighten the (2) bolts on the front side of the passenger side rear No. 1 seat assembly.
- e. Repeat for driver's side

NOTE: Be sure not to damage the airbag connector or harness when installing the seat bolt.

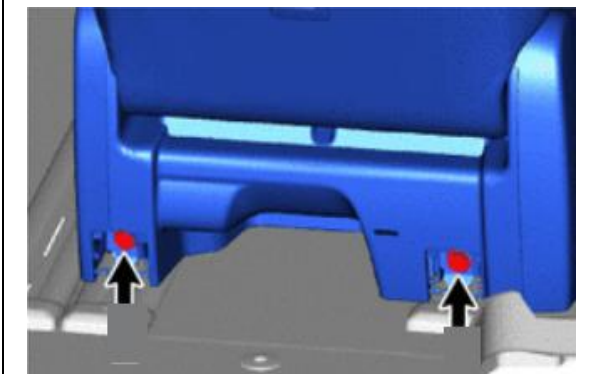

- f. Install the (2) bolts on the rear side of the driver side rear No.1 seat assembly.
- g. Repeat for driver's side.



- h. Torque all (4) bolts to **65 N·m {48 ft·lbf}**.
- i. Repeat for driver's side.

9. REINSTALLING THE AIRBAG WIRING HARNESS

- a. Reinstall the airbag connector
- b. Repeat for driver's side

HINT:

- Before connecting the connector, check that the position of the release button is as shown in the illustration below.
- While holding the sides of the connector, slide the connector in the direction shown by the arrow in the illustration until a click sound is heard to connect the airbag connector, and check that the release button is in its original position.

NOTE:

- Slide the connector in straight to connect it. Be careful not to pry the connector.

- To prevent deformation of the connector and possible damage to the partial engagement prevention mechanism, do not press down on the top surface of the connector when connecting it. Be sure to hold the connector by the sides.

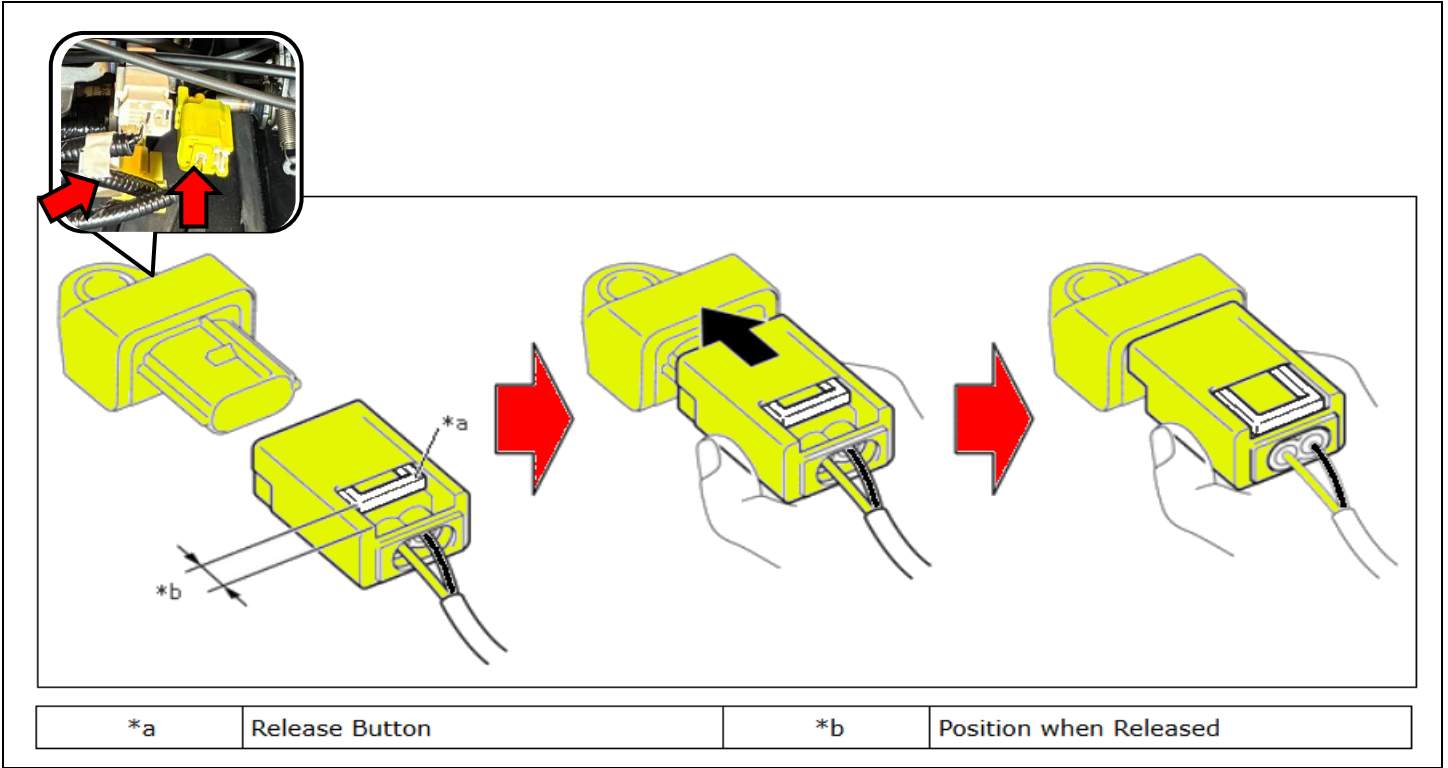

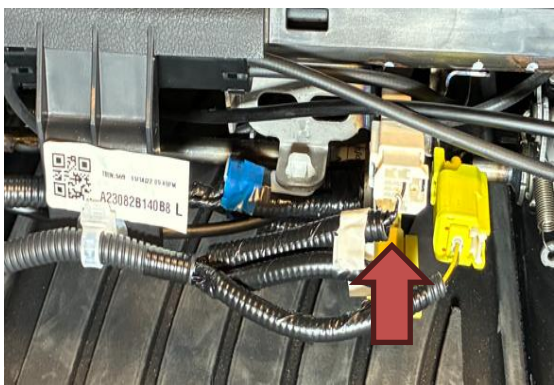

- c. Reconnect the white connector.
- d. Repeat for driver's side.

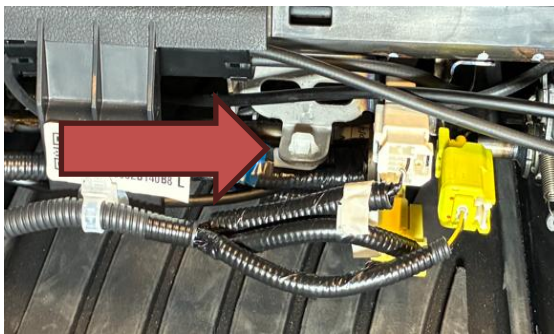

- e. Attach the harness clips to the seat assembly.
- f. Repeat for driver's side



- g. Reinstall seat front & rear seat covers
- h. Repeat for driver's side

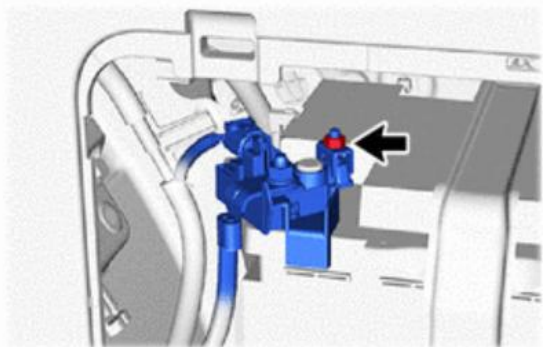

10. CONNECT 12V BATTERY.

- a. Connect negative battery terminal.
- b. If equipped with power doors, initialize power doors by manually opening and closing left, right and rear door.
- c. Test for correct function of sunroof & auto up/down windows, if needed perform initialization procedure.



11. CHECK SRS WARNING LIGHT

- a. Turn the ignition switch to ON and check that the SRS warning light turns on.
- b. Turn the ignition switch off. Wait for at least 2 seconds, then turn the ignition switch to ON. The SRS warning light comes on for approximately 6 seconds, a diagnosis of the airbag system is performed, and then the light turns off.

NOTE: If the SRS warning light remains on for longer than 6 seconds after the ignition switch has been turned to ON, there may be a malfunction in the SRS airbag system.

12. APENDIX

a. PARTS DISPOSAL

In accordance with Federal law, please make sure all recalled parts (original parts) removed from the vehicle are disposed of in a manner in which they will not be reused, unless requested for parts recovery return.

◀ VERIFY REPAIR QUALITY ▶

- Confirm that the SRS warning light turns off after approximately 6 seconds.
- Confirm all seat covers and trim panels are correctly installed.
- Confirm seats slide smoothly on new rails.