



◀ IMPORTANT UPDATE ▶

The attached Technical Instructions has been updated. Refer to the details below.

DATE	TOPIC
5/21/2026	Phase 3 Launch – Meter replacement only
4/3/2026	Added new Calibration IDs chart if OTA is completed
1/20/2026	RX models – Combination meter replacement only – Software update is not required added to calibration chart
1/15/2026	Phase 2 Launch

The most recent update in the attached Dealer Letter will be highlighted with a red box.

Please review this notification with your staff to assure that all relevant personnel have been briefed regarding this subject.

Thank you for your cooperation.

TECHNICAL INSTRUCTIONS
FOR
25LA05
COMBINATION METER ASSEMBLY – REPLACEMENT ONLY
CERTAIN 2024 TX 550h+ vehicles

The repair quality of covered vehicles is extremely important to Lexus. All dealership technicians performing this recall are required to successfully complete the most current version of the E-Learning course “Safety Recall and Service Campaign Essentials”. To ensure that all vehicles have the repair performed correctly; technicians performing this recall repair are required to currently hold at least one of the following certification levels:

- LIC206A – Electrical Repair 1

It is the dealership’s responsibility to select technicians with the above certification level or greater to perform this recall repair. Carefully review your resources, the technician skill level, and ability before assigning technicians to this repair. It is important to consider technician days off and vacation schedules to ensure there are properly trained technicians available to perform this repair at all times.

I. OPERATION FLOW CHART

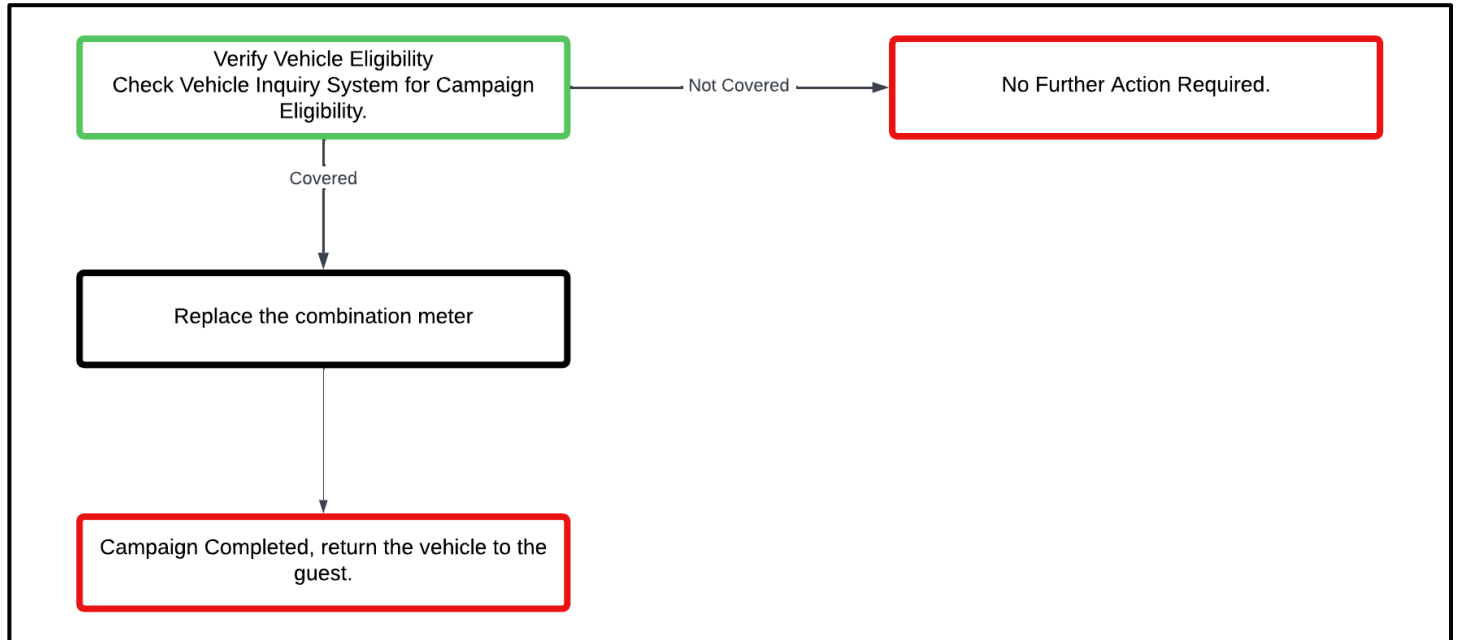

II. IDENTIFICATION OF AFFECTED VEHICLES

1. CHECK VEHICLE FOR CAMPAIGN ELIGIBILITY

- a) Compare the vehicles VIN to the VIN listed on the Repair Order to ensure they match.
- b) Check the TIS Vehicle Inquiry System to confirm the VIN is involved in this Campaign, and that it has not already been completed.

NOTICE:

Lexus warranty will not reimburse dealers for repairs completed on vehicles that are not affected or were previously completed, even by another dealer.

III. PREPARATION

A. PARTS

Part Number	Part Description	Quantity
83A00-0E241-RP	Combination Meter Assembly	1

B. TOOLS & EQUIPMENT

- L-SB-0001-18 Rev. 2
- DCA-8000 Battery Diagnostic Station
- GTS+

IV. WORK PROCEDURE TABLE OF CONTENTS

BACKGROUND	SECTION V.
SAFETY PRECAUTIONS	SECTION VI.
COMBINATION METER SYSTEM CALIBRATION ID VERIFICATION	SECTION VII.
VEHICLE PREPERATION	SECTION VIII.
UPDATE CALIBRATION	SECTION IX.
COMPLETE REPAIR	SECTION X.
APPENDIX	SECTION XI.

V. BACKGROUND

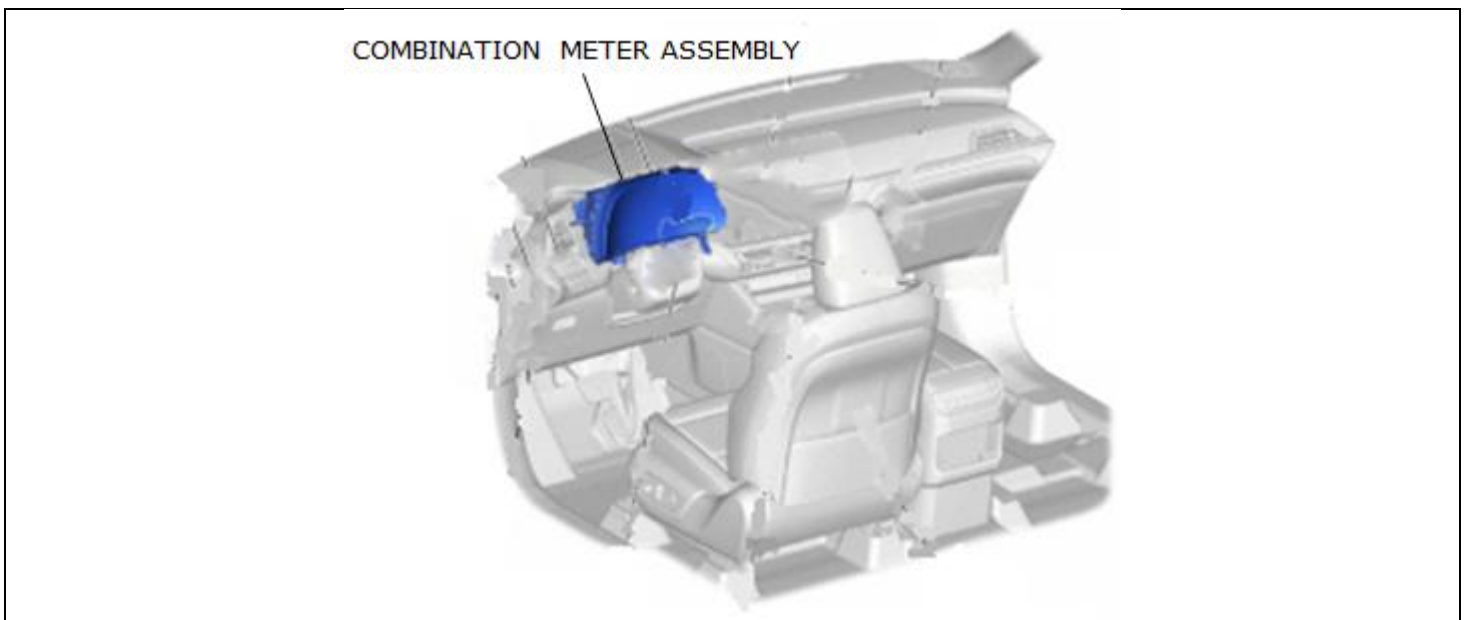

VI. SAFETY PRECAUTIONS

Critical CRITICAL INFORMATION - READ THOROUGHLY

An ECU could be damaged if an error occurs in the communication while reprogramming the ECU. Confirm all work is performed as described in these instructions.

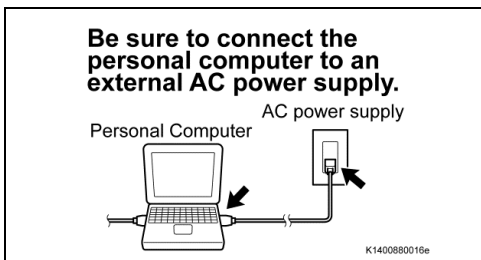

1. STABILIZE THE POWER TO THE PERSONAL COMPUTER SIDE

- a) Be sure to connect the personal computer to an external AC power supply.

NOTE:
The ECU could be damaged if the battery voltage of the personal computer drops while reprogramming.

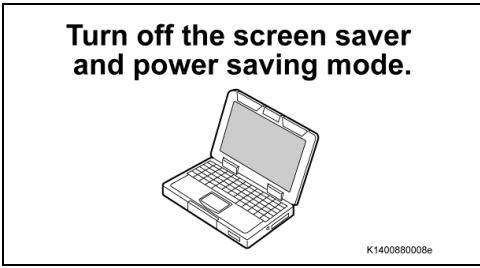

- b) Turn off the screen saver and power saving mode of the personal computer so that the power to the hard disk is kept supplied.

NOTE:

If the screen saver or power saving mode launches while reprogramming, the communication may be disconnected, resulting in the damage of the ECU.



- c) **DO NOT** block the ventilation opening for the cooling fan of the personal computer.

NOTE:

If the ventilation opening for the cooling fan is blocked with a sheet cover or the like, the personal computer may be heated excessively, causing the operation of the personal computer to stop.

Due to the stop of the operation, the communication for reprogramming signals could be stopped, resulting in the damage of the ECU.

VII.COMBINATION METER SYSTEM CALIBRATION ID VERIFICATION

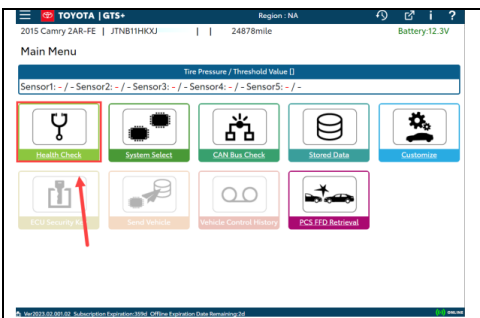

1. CHECK FOR DTC'S

- a) Using a GTS+, click the “Health Check” button on the Main Menu.

HINT:

This Campaign covers only the software update to the Engine System, as detailed in these instructions. It does not cover the diagnosis or replacement of any other systems on the vehicle.

2. CHECK CURRENT CALIBRATION

- a) Locate the “Update” column of the “Calibration Information” for the Combination Meter system on the “Health Check Result” screen.
- b) Determine the status of an available update; indicated by a YES or NO.

HINT:

If the CIDs indicate ‘Yes’, proceed with the update procedure.

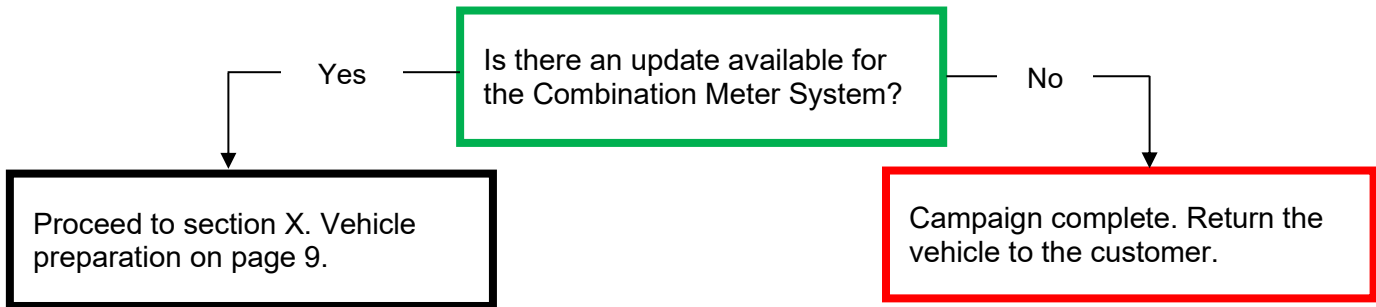
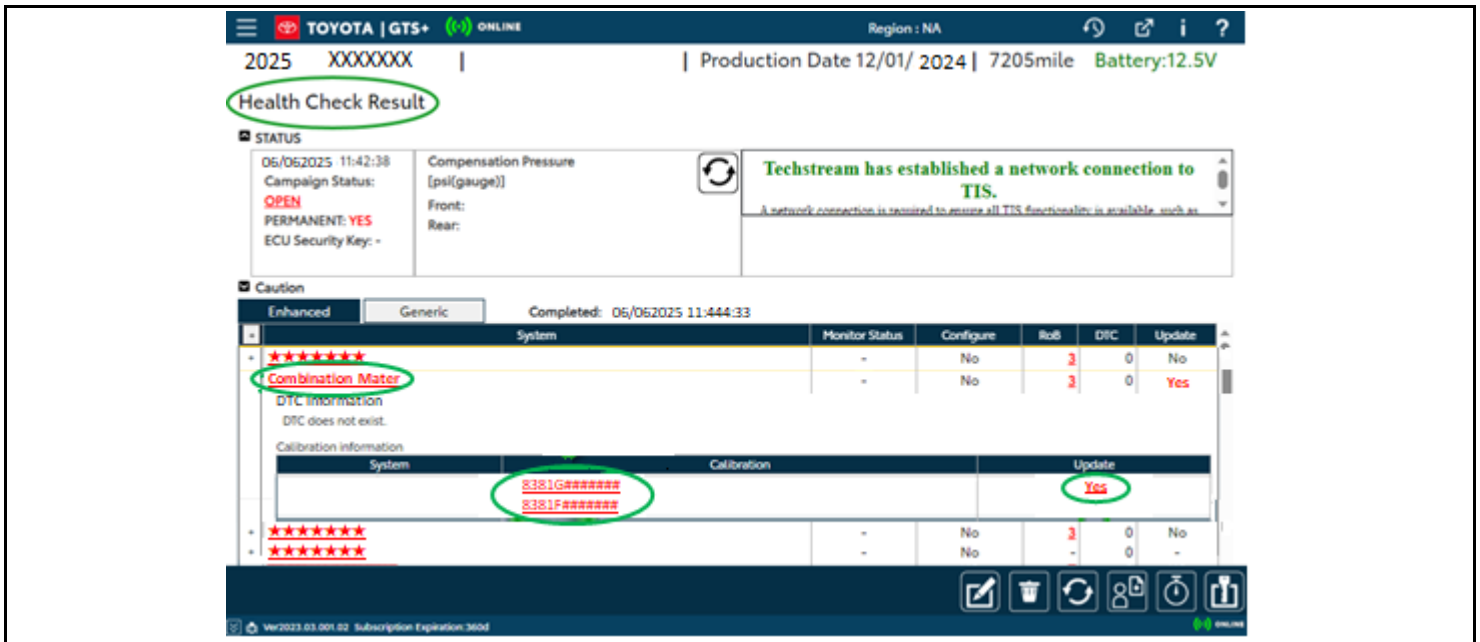

◀ CRITICAL MESSAGE ▶

It is critical that L-SB-0107-20 Rev. 2 in addition to the Technical Instructions for this Recall [or LSC/CSC] are followed. This LSB outlines all steps necessary to prevent reprogramming failure. Lexus will not provide reimbursement coverage for reprogramming failures if this LSB is not followed. If you have a reprogramming failure that requires COMBINATION METER ASSEMBLY replacement and the Technical Instructions and LSB were followed correctly, please create a case with the Technical Assistance Hotline documenting all information related to the failure. If sufficient reporting is received related to re-flash failure, there will be consideration for reimbursement.

VIII. VEHICLE PREPERATION

1. VEHICLE PREPERATION

a) Confirm the following conditions:

- Vehicle in the IG position (READY OFF).
- Transaxle in Park.
- Parking brake engaged.
- Turn off all electrical accessories (i.e. climate control, audio system, etc.)
- Headlight switch in the DRL OFF position.
- Windshield wiper switch in the OFF position.

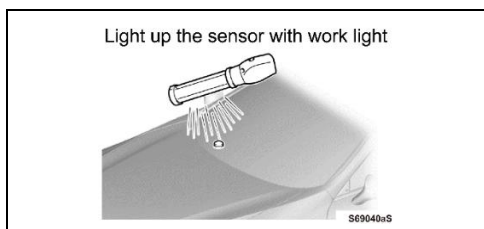

- b) When the vehicle has no "OFF position" in the light control switch:
- i. Turn the IG ON.
 - ii. Set the light control switch to the AUTO position and make sure that the exterior lights are turned on.
 - iii. Light up the automatic light control sensor with work light to keep the exterior lights turned off.

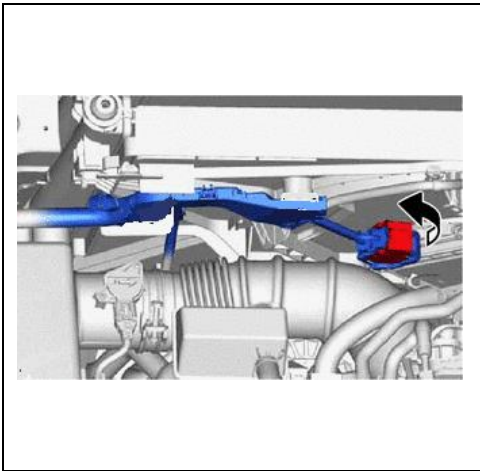

2. for Hybrid Vehicles:

STOP THE OPERATION OF THE COOLING FAN

- a) Disconnect the connector from the cooling fan.
- i. Rotate the lever while pushing the lock, and disconnect the cooling fan motor connector.

NOTICE:

After disconnecting the cooling fan motor connector, make sure that the dirt, water or other foreign matter does not contact the connecting parts of the cooling fan motor connector.



A power supply **MUST** be used during reprogramming. ECU damage will occur if the battery voltage is not properly maintained during this re-flash procedure.

3. CONNECT THE 12V BATTERY TO A POWER SUPPLY

- a) Connect the DCA-8000 or other type of a power supply (not a battery charger) to the 12V battery.
- b) Select the Power Supply Mode from the Main Menu of the DCA-8000.



A power supply **MUST** be used during reprogramming. ECU damage will occur if the battery voltage is not properly maintained during this re-flash procedure.

NOTICE:

A power supply must be connected directly to the 12V battery terminals and **NOT** the remote jump posts under the hood (if equipped).

4. VERIFY GTS+ SETUP

- a) Verify that the GTS+ meets the following conditions:
 - The latest version of software is loaded.
 - The GTS+ battery is fully charged. If not, connect the GTS+ to a 120V source.
 - The DLCIII cable is in good condition.



The GTS+'s battery voltage must also be maintained during the re-flash procedure. If necessary, plug the GTS+ into a 120v outlet during this procedure.

NOTICE:

If the GTS+ communication with the vehicle fails during the re-flash procedure, the Combination Meter Assembly will be damaged.

IX. UPDATE CALIBRATION

IMPORTANT OTA INFORMATION

If OTA (Over the Air update) has been performed by the guest the CID will be different than the GTS+ new CID. Please reference the chart below for the affected models.

Vehicle Model	Current		New			
			GTS+		OTA	
	CID	Version	CID	Version	CID	Version
Lexus LS	8381F5007200	1002	8381F5007400	1004	8381F5007500	1005
	8381F5007300	1003				
Lexus TX	8381F0E01100	1004	8381F0E01300	1009	8381F0E01500	1011

1. CONFIRM THE CALIBRATION ID FOR THE COMBINATION METER SYSTEM

a) Confirm the current calibration ID in the Combination Meter System.

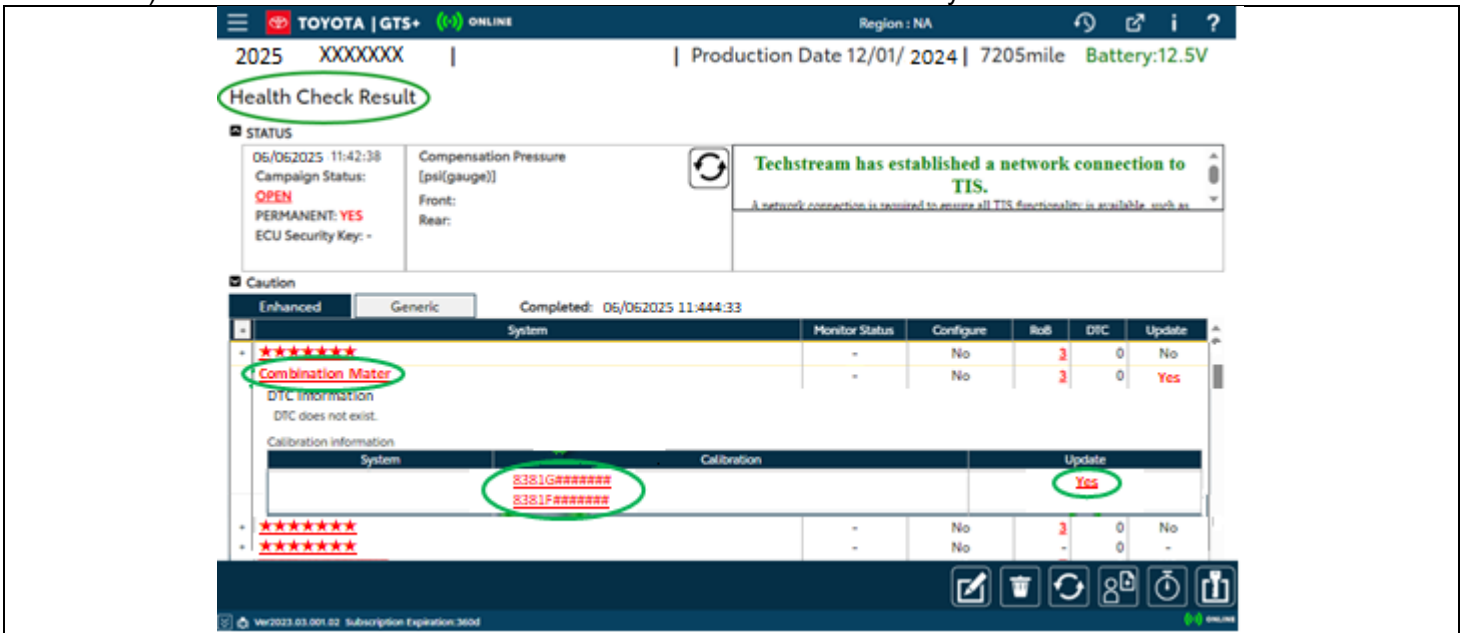

The calibration IDs to re-flash in this campaign are as shown in the table below.

Combination Meter System Calibrations		
Model	Current Calibration ID	New Calibration ID
TX550h+	CID-1: ##### CID-2: 8381F0E1 <u>10100</u>	CID-1: ##### CID-2: 8381F0E14000

NOTICE:

If the Combination Meter has the **New CIDs**, no update is necessary.

2. REFLASH THE COMBINATION METER

- a) Click “yes” on the “Health Check Results” screen, or follow the links on the table above the begin the reflash process.

NOTICE:

Reflash failure should be extremely rare and can be avoided by following all instructions and reprogramming best practices.

X. COMPLETE REPAIR

1. DISCONNECT THE DCA-8000

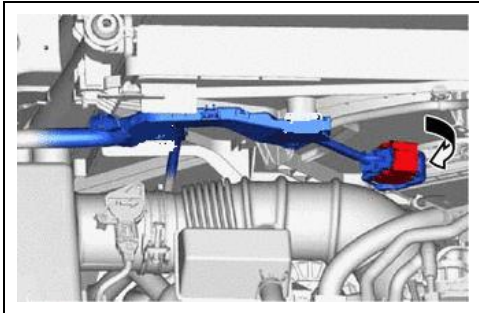

2. for Hybrid Vehicles: RECONNECT COOLING FAN WIRE CONNECTOR

- a) Connect the cooling fan motor connector and lock it with lever.

NOTICE:

- When connecting the connectors, make sure that dirt, water or other foreign mater does not become stuck between the connectors and other parts.
- Make sure that the lever is securely locked.

3. for Hybrid Vehicles: CHECK THE OPERATION OF THE ELECTRIC FAN

- a) Turn the READY ON.
- b) Turn the air conditioner ON to check if the electric fan operation.

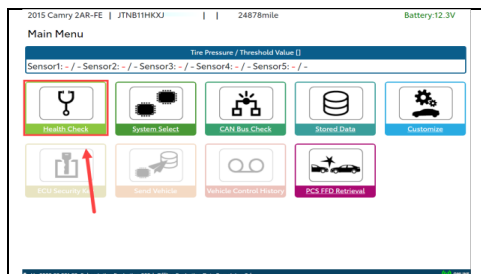

4. PERFORM VERIFICATION HEALTH CHECK

- a) Using a GTS+, perform a Health Check.
- b) Clear DTC's that may have set during the re-flash procedure.
- c) Re-run the Health Check to confirm that no DTC's reappear.

Critical

THIS VERIFICATION HEALTH CHECK IS NECESSARY to update the results and CIDs to the National database.

5. CONFIRM CID UPDATE

- a) On the Stored Data tab, confirm the following for the Combination Meter System:
 - The Calibration number has the “**NEW CID**” number.
 - The Update column says “No”.

Critical Confirm the CIDs has been updated successfully to the **NEW CIDs** by someone other than the individual who performed the repair. Refer to page 6.

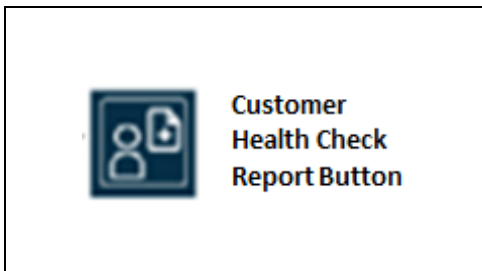

6. PRINT GUEST HEALTH CHECK REPORT

- a) From the Stored Data tab, select the Guest Health Check Report button (TIS will launch when button is pressed).
- b) Log in to TIS.
- c) Input Vehicle Mileage and Repair Order number.
- d) Check the “Performed” campaign button for the applicable campaigns.
- e) Select the Report button.

- f) Confirm Guest Health Check Report information is correct.
- g) Print Guest Health Check Report from TIS.
- h) Sign and provide to the guest.

◀ VERIFY REPAIR QUALITY ▶

- **Confirm the reflash completes successfully.**
- **Confirm there are no DTCs after the Calibration update.**
- **If you have any questions regarding this update, please contact your area representative.**

XI. APPENDIX

A. CAMPAIGN DESIGNATION DECODER

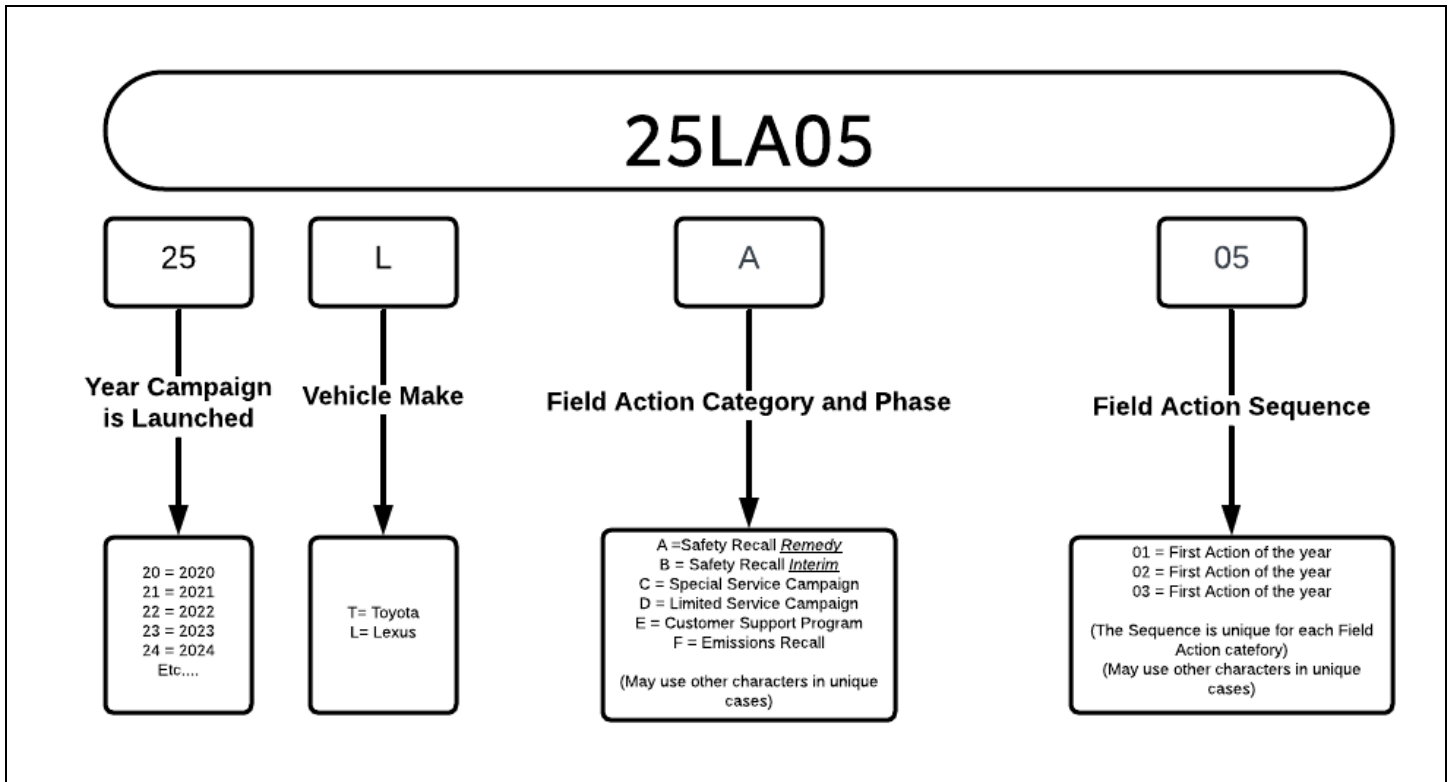

Examples:

19LA01 = Launched in 2019, Toyota, Safety Recall Remedy Phase, 1st Safety Recall Launched in 2019
20LC02 = Launched in 2020, Special Service Campaign, 2nd Special Service Campaign Launched in 2020
21LE05 = Launched in 2021, Customer Support Program, 5th Customer Support Program Launched in 2021