



# SAFETY RELATED RECALL

Global Recall Action  
Number: D027

<b>Subject:</b>  <b>Range Rover (L405) Front Suspension Knuckle Crack</b>	Publication No.: D027
	Model: Range Rover (LG)
	Model Year: 2015 - 2017
	Date of Issue: 17 April 2026

<b>To:</b>	Jaguar Land Rover North America, LLC Jaguar Land Rover Canada ULC
<b>For the Attention of:</b>	The approved JLR retailer / authorized repairer.
<b>Important:</b>	NOTE: The information in this campaign is intended for use by professional technicians. If you are not a JLR retailer / authorized repairer, do not assume that a condition described affects a specific vehicle. Contact an authorized JLR retailer / authorized repairer to determine if this campaign applies to a specific vehicle.

## FOR THE ATTENTION OF ALL:

### DESCRIPTION OF ISSUE AND THE EFFECT ON VEHICLE OPERATION

A concern has been identified on certain 2015 model year to 2017 model year Range Rover vehicles, where the front suspension upper knuckle joint could develop a crack. In extreme cases this may lead to detachment of the upper suspension arm.

In cases where a crack in the front suspension knuckle has developed, the environmental conditions in the markets may lead to a worsening of the crack and an eventual detachment of the upper suspension arm, which under extreme avoidance maneuver use conditions may compromise the vehicle's controllability and increase the risk of a crash.

D027 is applicable to additional vehicles not captured within campaigns N759 or D041 together with certain unrepaired Canadian vehicles previously included in N759, and certain Canadian vehicles repaired under N759 but deemed to still be at risk.

### ACTION TO BE TAKEN

JLR has taken the decision to recall affected vehicles to repair the vehicle.

Following procedures appropriate to your market and as required by local legislation, owners of affected vehicles must be contacted requesting that the owner contact their nearest JLR retailer / authorized repairer as soon as possible to arrange for the repair to be completed. The National Sales Company (NSC), Importer, Regional Office or Government agency will contact the customers. If you have any questions about this process, contact your NSC / Importer or Regional Office for more information.

Check the JLR Warranty Portal to make sure affected vehicles are correctly identified prior to starting this campaign. The Warranty Portal will be updated to reflect only those vehicles affected.

JLR retailers / authorized repairers are reminded that they must not sell vehicles identified as affected by this campaign until such time as the repair has been successfully completed.

An owner may indicate that a repair has already been completed for this concern, in which case the full cost of the repair should be reimbursed. Refer to the warranty section of this campaign for details of the Customer Reimbursement and Related Damage Process. At the time of confirming a booking for a vehicle repair, make sure you check the Warranty Portal to confirm if there are any other outstanding campaigns, to make sure the correct parts are available and adequate workshop time is allocated for repairs to be completed in one visit.

For information purposes, a Technical Question and Answer document is attached.

### FOR THE ATTENTION OF NORTH AMERICAN TERRITORIES ONLY:

Transport Canada (TC) reference number: 2025-338

National Highway Traffic Safety Administration (NHTSA) reference number: 25V-514

Visit the British Brands Sales Suite (BBSS) website for a list of affected vehicles at your JLR retailer / authorized repairer. Unsold vehicles must be repaired prior to handover of the vehicle for retail sale.

### REGULATORY INFORMATION

Jaguar Land Rover North America, LLC and Jaguar Land Rover Canada ULC have informed the National Highway Traffic Safety Administration (NHTSA) and Transport Canada (TC) of their intent to perform a Safety Recall on certain 2015 model year to 2017 model year Range Rover vehicles imported into the United States and Canadian markets. Information relating to this Safety Recall will be posted on the NHTSA and TC websites. United States Federal regulations require that JLR retailers / authorized repairers must be notified within a reasonable time after the manufacturer decides that a defect that relates to motor vehicle safety or a non-compliance exists. United States Federal Law requires JLR retailers / authorized repairers to complete any outstanding Safety Recall before a new vehicle is delivered to the buyer or lessee. Violation of this requirement by a JLR retailers / authorized repairers, in the USA only, could result in a maximum civil penalty of up to the equivalent of \$27,168.00 USD per violation and the equivalent of \$135,828,178.00 USD for a related series of violations. This Safety Recall serves as notification to all JLR retailers / authorized repairers in the United States and Federalized Territories and Canada that any affected new vehicles may not be sold and delivered for customer use until the Safety Recall repair is completed.

Jaguar Land Rover North America, LLC and Jaguar Land Rover Canada ULC recommends that affected sales demonstrator and loaner vehicles are repaired before use, and that used vehicles are repaired before sale. JLRretailers / authorized repairers who proceed against this recommendation, where legally permitted, must clearly and conspicuously disclose the open Safety Recall notice to the applicable customers.

Yours faithfully

Steve Oldham

Global Customer Care Quality Director

**SERVICE INSTRUCTION - D027**

Changes are highlighted in blue

**Parts Information****NOTES:**

- \*An allowance equivalent to £1.00 Sterling has been allocated to locally source Loctite© 243.
- \*\*An allowance equivalent to £0.10 Sterling has been allocated to locally source a suitable paint pen.
- 1 paint pen will be sufficient to cover 50 vehicles.

Description	Part Number/Sundry Code	Qty/£ value	% vehicles requiring parts
Front knuckle - Right	LR146341	1	50
Front knuckle - Left	LR146343	1	50
Front knuckle bolt - M10x70mm	KYG000230	2	50
Front knuckle nut - M10	FY110056	2	50
Front knuckle nut - M16	LR034221	4	50
Hub nut - M24x2.0mm	LR024151	2	50
Caliper bolt - M16x40mm	LR033274	4	50
Tie-rod nut	LR026275	2	50
Front knuckle bracket	602123505	2	50
Loctite© 243	*ZZZ999	£1.00	50
Paint pen	**ZZZ999	£0.10	50

When ordering parts, order no more than the expected percentage failure rate of parts identified.

**SROs**

Description	SRO	Time
Complete Service Inspection 1	05.10.10	0.1
Complete Service Inspection 2 - Single	99.03.66	0.5
Complete Service Inspection 2 - Pair	99.03.63	1
Complete Service Inspection 3 - Single	99.03.68	0.2
Complete Service Inspection 3 - Pair	99.03.67	0.4
Install 1 bracket	05.10.20	0.2
Install 2 brackets	05.10.40	0.4
Renew 1 knuckle	05.10.90	0.9
Renew 2 knuckles	05.11.17	1.7
Drive in / drive out	02.02.02	0.2

**NOTE:**

Repair procedures are under constant review, and therefore times are subject to change; those quoted here must be taken as guidance only. Always refer to TOPIx to obtain the latest repair time.

**Warranty Information**

Warranty claims must be submitted quoting program code D027 with the relevant option code from the table below. As option codes are used there is no requirement for you to enter SROs or parts, these are included for information only.

Program	Option	Description	SRO	Time	Part Number / Sundry Code	Qty / £ Value
D027	A	Complete Service Inspection 1	05.10.10	0.1	N/A	N/A
D027	B	Complete Service Inspection 1 Drive in / drive out	05.10.10 02.02.02	0.1 0.2	N/A	N/A
D027	C	Complete Service Inspection 1 Complete Service Inspection 2 - Single	05.10.10 99.03.66	0.1 0.5	LR033274 **ZZZ999	2 £0.10
D027	D	Complete Service Inspection 1 Complete Service Inspection 2 - Single Drive in / drive out	05.10.10 99.03.66 02.02.02	0.1 0.5 0.2	LR033274 **ZZZ999	2 £0.10
D027	CA	Complete Service Inspection 1 Complete Service Inspection 2 - Pair	05.10.10 99.03.63	0.1 1	LR033274 **ZZZ999	4 £0.10
D027	DA	Complete Service Inspection 1 Complete Service Inspection 2 - Pair Drive in / drive out	05.10.10 99.03.63 02.02.02	0.1 1 0.2	LR033274 **ZZZ999	4 £0.10
D027	E	Complete Service Inspection 1 Complete Service Inspection 2 - Single Complete Service Inspection 3 - Single Install 1 bracket	05.10.10 99.03.66 99.03.68 05.10.20	0.1 0.5 0.2 0.2	LR033274 602123505 *ZZZ999 **ZZZ999	2 1 £1.00 £0.10
D027	F	Complete Service Inspection 1 Complete Service Inspection 2 - Single Complete Service Inspection 3 - Single Install 1 bracket Drive in / drive out	05.10.10 99.03.66 99.03.68 05.10.20 02.02.02	0.1 0.5 0.2 0.2 0.2	LR033274 602123505 *ZZZ999 **ZZZ999	2 1 £1.00 £0.10
D027	G	Complete Service Inspection 1 Complete Service Inspection 2 - Single Complete Service Inspection 3 - Single Renew left knuckle	05.10.10 99.03.66 99.03.68 05.10.90	0.1 0.5 0.2 0.9	LR146343 KYG000230 FY110056 LR024151 LR033274 LR034221 LR026275 **ZZZ999	1 1 1 1 2 2 1 £0.10
D027	H	Complete Service Inspection 1 Complete Service Inspection 2 - Single Complete Service Inspection 3 - Single Renew left knuckle Drive in / drive out	05.10.10 99.03.66 99.03.68 05.10.90 02.02.02	0.1 0.5 0.2 0.9 0.2	LR146343 KYG000230 FY110056 LR024151 LR033274 LR034221 LR026275 **ZZZ999	1 1 1 1 2 2 1 £0.10
D027	I	Complete Service Inspection 1 Complete Service Inspection 2 - Single Complete Service Inspection 3 - Single Renew right knuckle	05.10.10 99.03.66 99.03.68 05.10.90	0.1 0.5 0.2 0.9	LR146341 KYG000230 FY110056 LR024151 LR033274 LR034221 LR026275 **ZZZ999	1 1 1 1 2 2 1 £0.10
D027	J	Complete Service Inspection 1 Complete Service Inspection 2 - Single Complete Service Inspection 3 - Single Renew right knuckle Drive in / drive out	05.10.10 99.03.66 99.03.68 05.10.90 02.02.02	0.1 0.5 0.2 0.9 0.2	LR146341 KYG000230 FY110056 LR024151 LR033274 LR034221 LR026275 **ZZZ999	1 1 1 1 2 2 1 £0.10
D027	K	Complete Service Inspection 1 Complete Service Inspection 2 - Pair Complete Service Inspection 3 - Single Install 1 bracket	05.10.10 99.03.63 99.03.68 05.10.20	0.1 1 0.2 0.2	LR033274 602123505 *ZZZ999 **ZZZ999	4 1 £1.00 £0.10
D027	L	Complete Service Inspection 1 Complete Service Inspection 2 - Pair Complete Service Inspection 3 - Single Install 1 bracket Drive in / drive out	05.10.10 99.03.63 99.03.68 05.10.20 02.02.02	0.1 1 0.2 0.2 0.2	LR033274 602123505 *ZZZ999 **ZZZ999	4 1 £1.00 £0.10

Program	Option	Description	SRO	Time	Part Number / Sundry Code	Qty / £ Value
D027	M	Complete Service Inspection 1	05.10.10	0.1	LR146343	1
		Complete Service Inspection 2 - Pair	99.03.63	1	KYG000230	1
		Complete Service Inspection 3 - Single	99.03.68	0.2	FY110056	1
		Renew left knuckle	05.10.90	0.9	LR024151	1
					LR033274	4
					LR034221	2
					LR026275	1
			**ZZZ999		£0.10	
D027	N	Complete Service Inspection 1	05.10.10	0.1	LR146343	1
		Complete Service Inspection 2 - Pair	99.03.63	1	KYG000230	1
		Complete Service Inspection 3 - Single	99.03.68	0.2	FY110056	1
		Renew left knuckle	05.10.90	0.9	LR024151	1
		Drive in / drive out	02.02.02	0.2	LR033274	4
					LR034221	2
					LR026275	1
			**ZZZ999		£0.10	
D027	P	Complete Service Inspection 1	05.10.10	0.1	LR146341	1
		Complete Service Inspection 2 - Pair	99.03.63	1	KYG000230	1
		Complete Service Inspection 3 - Single	99.03.68	0.2	FY110056	1
		Install right knuckle	05.10.90	0.9	LR024151	1
					LR033274	4
					LR034221	2
					LR026275	1
			**ZZZ999		£0.10	
D027	Q	Complete Service Inspection 1	05.10.10	0.1	LR146341	1
		Complete Service Inspection 2 - Pair	99.03.63	1	KYG000230	1
		Complete Service Inspection 3 - Single	99.03.68	0.2	FY110056	1
		Install right knuckle	05.10.90	0.9	LR024151	1
		Drive in / drive out	02.02.02	0.2	LR033274	4
					LR034221	2
					LR026275	1
			**ZZZ999		£0.10	
D027	R	Complete Service Inspection 1	05.10.10	0.1	LR033274	4
		Complete Service Inspection 2 - Pair	99.03.63	1	602123505	2
		Complete Service Inspection 3 - Pair	99.03.67	0.4	*ZZZ999	£1.00
		Install 2 brackets	05.10.40	0.4	**ZZZ999	£0.10
D027	S	Complete Service Inspection 1	05.10.10	0.1	LR033274	4
		Complete Service Inspection 2 - Pair	99.03.63	1	602123505	2
		Complete Service Inspection 3 - Pair	99.03.67	0.4	*ZZZ999	£1.00
		Install 2 brackets	05.10.40	0.4	**ZZZ999	£0.10
		Drive in / drive out	02.02.02	0.2		
D027	T	Complete Service Inspection 1	05.10.10	0.1	LR146343	1
		Complete Service Inspection 2 - Pair	99.03.63	1	KYG000230	1
		Complete Service Inspection 3 - Pair	99.03.67	0.4	FY110056	1
		Renew left knuckle	05.10.90	0.9	LR024151	1
		Install right bracket	05.10.20	0.2	LR033274	4
					LR034221	2
					LR026275	1
			602123505	1		
			*ZZZ999	£1.00		
			**ZZZ999	£0.10		
D027	U	Complete Service Inspection 1	05.10.10	0.1	LR146343	1
		Complete Service Inspection 2 - Pair	99.03.63	1	KYG000230	1
		Complete Service Inspection 3 - Pair	99.03.67	0.4	FY110056	1
		Renew left knuckle	05.10.90	0.9	LR024151	1
		Install right bracket	05.10.20	0.2	LR033274	4
		Drive in / drive out	02.02.02	0.2	LR034221	2
					LR026275	1
					602123505	1
					*ZZZ999	£1.00
			**ZZZ999	£0.10		
D027	V	Complete Service Inspection 1	05.10.10	0.1	LR146341	1
		Complete Service Inspection 2 - Pair	99.03.63	1	KYG000230	1
		Complete Service Inspection 3 - Pair	99.03.67	0.4	FY110056	1
		Renew right knuckle	05.10.90	0.9	LR024151	1
		Install left bracket	05.10.20	0.2	LR033274	4
					LR034221	2

Program	Option	Description	SRO	Time	Part Number / Sundry Code	Qty / £ Value
					LR026275	1
					602123505	1
					*ZZZ999	£1.00
					**ZZZ999	£0.10
D027	W	Complete Service Inspection 1	05.10.10	0.1	LR146341	1
		Complete Service Inspection 2 - Pair	99.03.63	1	KYG000230	1
		Complete Service Inspection 3 - Pair	99.03.67	0.4	FY110056	1
		Renew right knuckle	05.10.90	0.9	LR024151	1
		Install left bracket	05.10.20	0.2	LR033274	4
		Drive in / drive out	02.02.02	0.2	LR034221	2
					LR026275	1
					602123505	1
					*ZZZ999	£1.00
					**ZZZ999	£0.10
D027	Y	Complete Service Inspection 1	05.10.10	0.1	LR146341	1
		Complete Service Inspection 2 - Pair	99.03.63	1	LR146343	1
		Complete Service Inspection 3 - Pair	99.03.67	0.4	KYG000230	2
		Renew 2 knuckles	05.11.17	1.7	FY110056	2
					LR024151	2
					LR033274	4
					LR034221	4
					LR026275	2
					**ZZZ999	£0.10
D027	Z	Complete Service Inspection 1	05.10.10	0.1	LR146341	1
		Complete Service Inspection 2 - Pair	99.03.63	1	LR146343	1
		Complete Service Inspection 3 - Pair	99.03.67	0.4	KYG000230	2
		Renew 2 knuckles	05.11.17	1.7	FY110056	2
		Drive in / drive out	02.02.02	0.2	LR024151	2
					LR033274	4
					LR034221	4
					LR026275	2
					**ZZZ999	£0.10

**NOTE:**

The option that contains the drive in / drive out allowance may only be claimed when the vehicle has been brought back into the workshop for this action alone to be undertaken.

Warranty claims must be submitted in accordance with the current JLR Global Warranty Manual, and its amendments, unless stated otherwise in this campaign.

**Customer Reimbursement and Related Damage Process****NOTE:**

If there is a requirement to claim for related / consequential damage or customer reimbursement, refer to the related instruction that can be found in TOPIx (in the Search box, search for 'Related Damage Claim' and open the related bulletin link).

**Table of Contents**
[REMOVAL AND INSTALLATION: SERVICE INFORMATION](#)
[REMOVAL AND INSTALLATION: SERVICE INSPECTION 1](#)
[REMOVAL AND INSTALLATION: SERVICE INSPECTION 2](#)
[REMOVAL AND INSTALLATION: SERVICE INSPECTION 3](#)
[REMOVAL AND INSTALLATION: FRONT WHEEL KNUCKLE REPLACEMENT](#)
[REMOVAL AND INSTALLATION: FRONT KNUCKLE BRACKET INSTALLATION PROCEDURE](#)
**SERVICE INFORMATION**

1. The illustration shows the front knuckle bracket components.

1. Front knuckle bracket side hooks.
2. Front knuckle bracket side hooks bolt.
3. Front knuckle bracket rear plate.
4. Front knuckle bracket rear plate bolts.

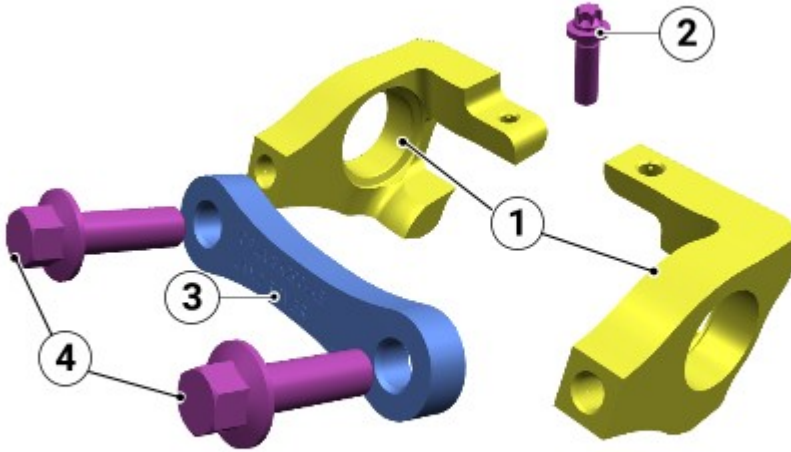

E377524

## SERVICE INSPECTION 1

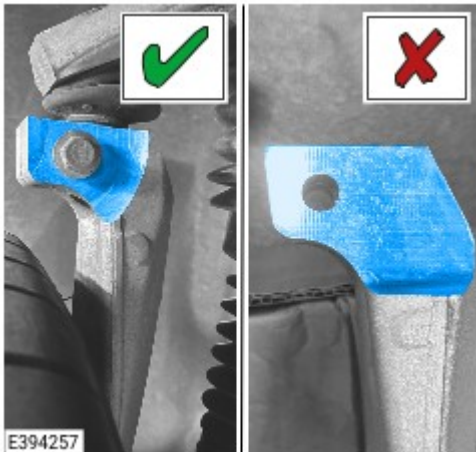

1.

### CAUTIONS:

- The vehicle may have either type of front wheel knuckle installed, both types of front wheel knuckles could be installed on the vehicle.
- Both front wheel knuckles must be inspected. The vehicle may have a different type of front wheel knuckle installed on the left side to the right side.

Inspect the front right wheel knuckle.

- If the front right wheel knuckle is the type shown in the illustration with the **GREEN ✓**, it has **PASSED** service inspection 1. No further action is required for the front right wheel knuckle, **continue to the next step**.
- If the front right wheel knuckle is the type shown in the illustration with the **RED X**, it has **FAILED** service inspection 1. **Continue to the next step**.

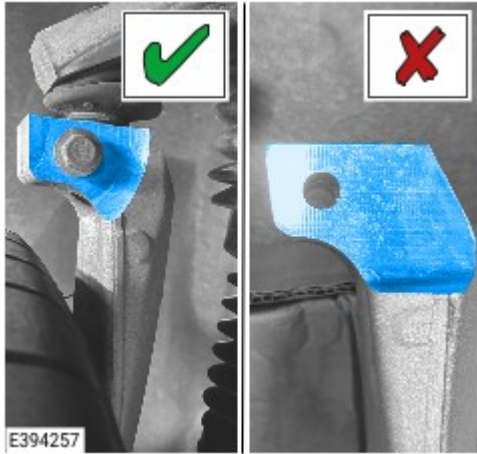

2.

**CAUTIONS:**

- The vehicle may have either type of front wheel knuckle installed, both types of front wheel knuckles could be installed on the vehicle.
- Both front wheel knuckles must be inspected. The vehicle may have a different type of front wheel knuckle installed on the left side to the right side.

Inspect the front left wheel knuckle.

- If the front left wheel knuckle is the type shown in the illustration with the **GREEN ✓**, it has **PASSED** service inspection 1. No further action is required for the front left wheel knuckle, **continue to the next step**.
- If the front left wheel knuckle is the type shown in the illustration with the **RED X**, it has **FAILED** service inspection 1. **Continue to the next step**.

3.

**NOTE:**

If both front knuckles are not affected and the vehicle is released, claim option code A or option code B from the warranty information table.

Service inspection 1 results:

- If both the front left and front right wheel knuckles **PASSED** Service inspection 1, **do not continue with this campaign and release the vehicle**.
- If both the front left and front right wheel knuckles **FAILED** Service inspection 1, **complete Service inspection 2 for both the front left and front right wheel knuckles**.
- If the front left wheel knuckle **PASSED** Service inspection 1 and the front right wheel knuckle **FAILED** service inspection 1, **complete Service inspection 2 for the front right wheel knuckle ONLY**.
- If the front right wheel knuckle **PASSED** Service inspection 1 and the front left wheel knuckle **FAILED** service inspection 1, **complete Service inspection 2 for the front left wheel knuckle ONLY**.

**SERVICE INSPECTION 2**

Only complete Service Inspection 2 for the wheel knuckle(s) that have **FAILED** Service Inspection 1.

1. Raise and support the vehicle on a suitable 2-post lift, (see TOPIx Workshop Manual section 100-02: Jacking and Lifting - Description and Operation).

2.

**NOTE:**

Do not discard the front brake caliper bolts during this step.

Remove the front brake disc (see TOPIx Workshop Manual section 206-03: Front Disc Brake - Removal and Installation - Brake Disc).

- Using a suitable method, clean the area highlighted in the illustration.

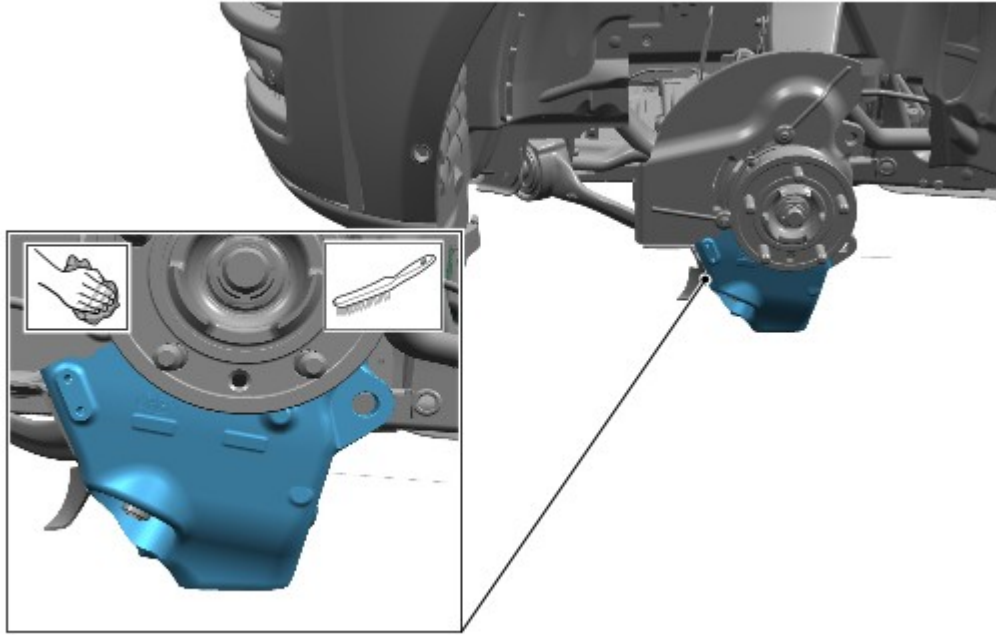

E405754

- Using a paint pen, apply paint to the front wheel knuckle part number. The part number will be in the location shown in the illustration, on every front wheel knuckle.

- Using a suitable cloth, remove excess paint from the part number.



E405755

5.

**NOTE:**

Shining a flashlight on the front wheel knuckle part number from above makes inspecting the front wheel knuckle part number easier.

Inspect the front wheel knuckle part number.

- If the front wheel knuckle part number is any of the following part numbers, the front wheel knuckle **has FAILED** Service Inspection 2, **continue to step 7**.
  - **CPLA-3K185-BA, CPLA-3K186-BA, DPLA-3K185-BA or DPLA-3K186-BA.**
- If the front wheel knuckle part number is any of the following part numbers, the front wheel knuckle **has PASSED** Service Inspection 2, **continue to step 6**.
  - **CPLA-3K185-BB, CPLA-3K186-BB or a suffix that starts with an A (xxxx-xxxx-Ax).**



E405756

6.

**CAUTIONS:**

- Discard the front brake caliper bolts retained during step 2.
- New front brake caliper bolts must be used during this step.

**NOTE:**

The front wheel knuckle(s) that have **PASSED** Service Instruction 2 do not require further action.

Install the front brake disc (see TOPIx Workshop Manual section 206-03: Front Disc Brake - Removal and Installation - Brake Disc).

7. If both front wheel knuckles **FAILED** Service Inspection 1, repeat steps 2 to 5 for the other side.

8. Continue to SERVICE INSPECTION 3.

## SERVICE INSPECTION 3

Only complete Service Inspection 3 for the wheel knuckle(s) that have **FAILED** Service Inspection 1 and **FAILED** Service Inspection 2.

1. Use a non abrasive cloth and suitable cleaning fluid to clean the area of the front wheel knuckle shown highlighted in the illustrations.

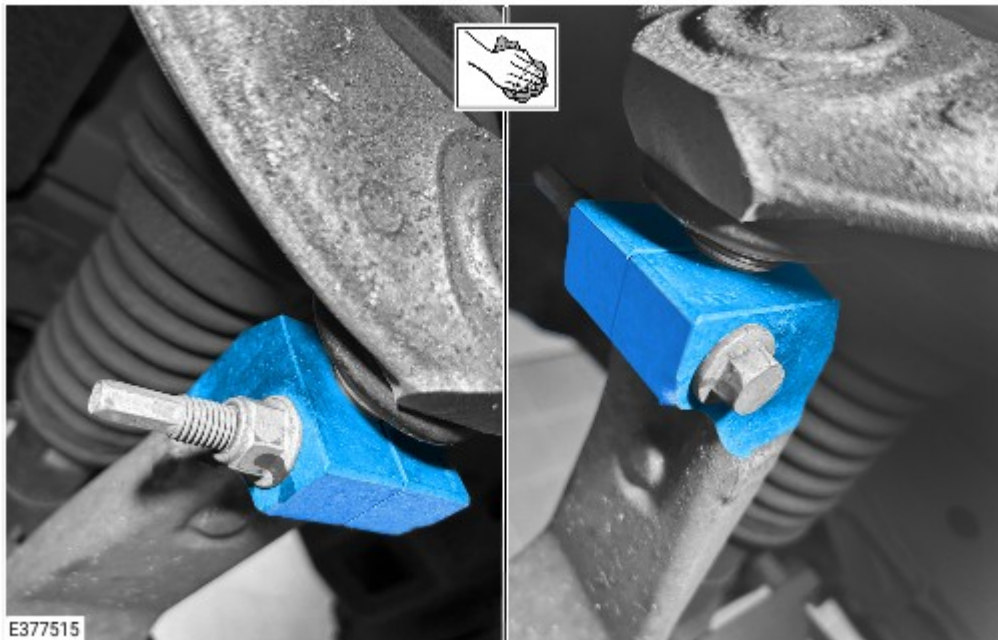
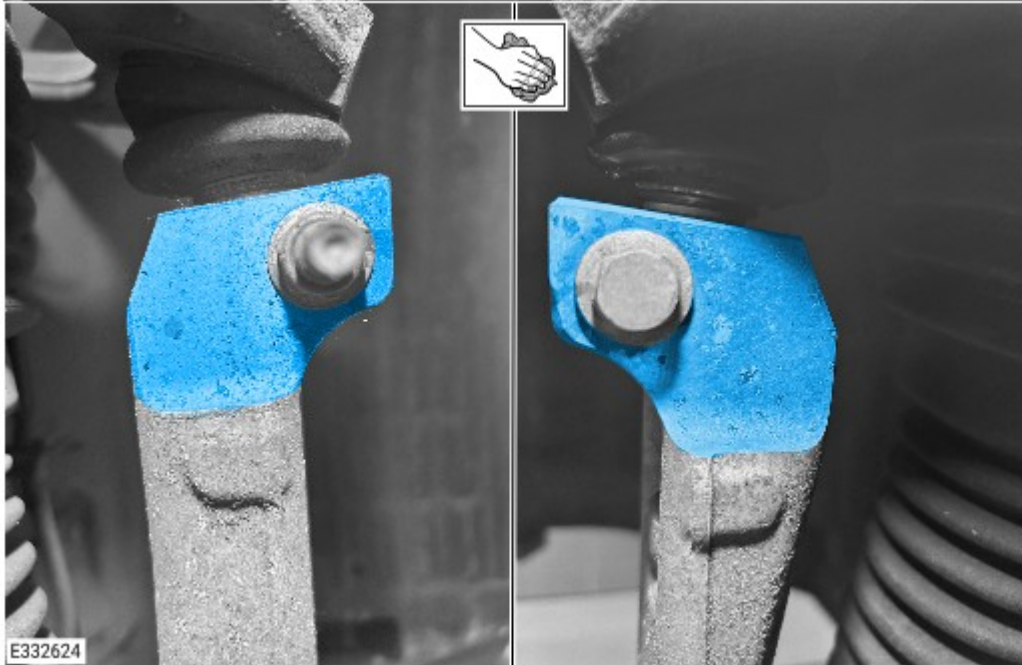

2. Carefully inspect the front wheel knuckle for visible cracks. Examples of cracks are shown in the next step.

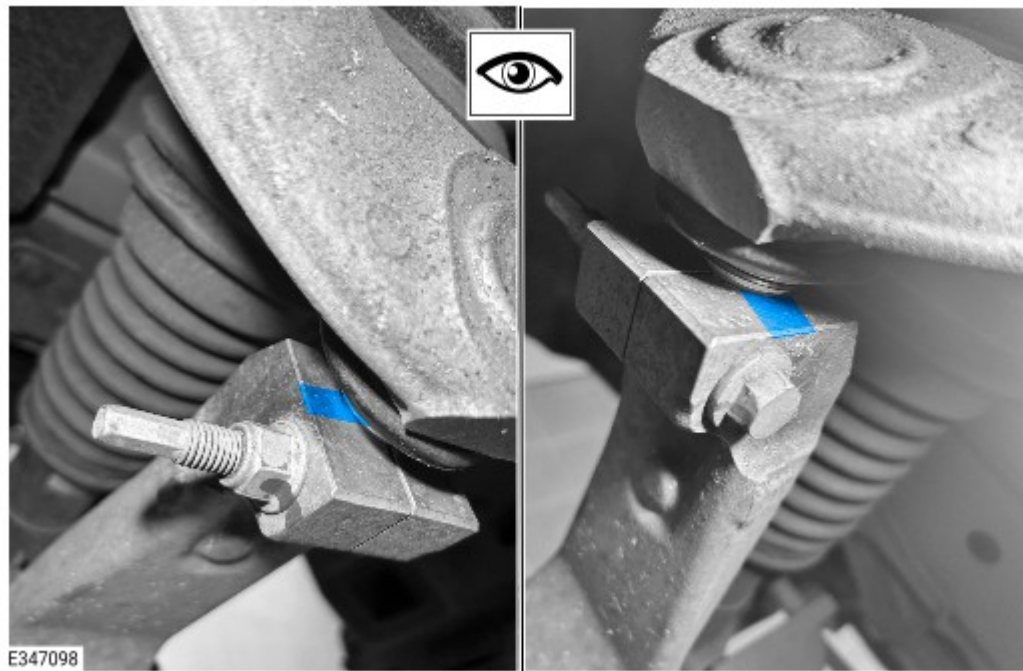
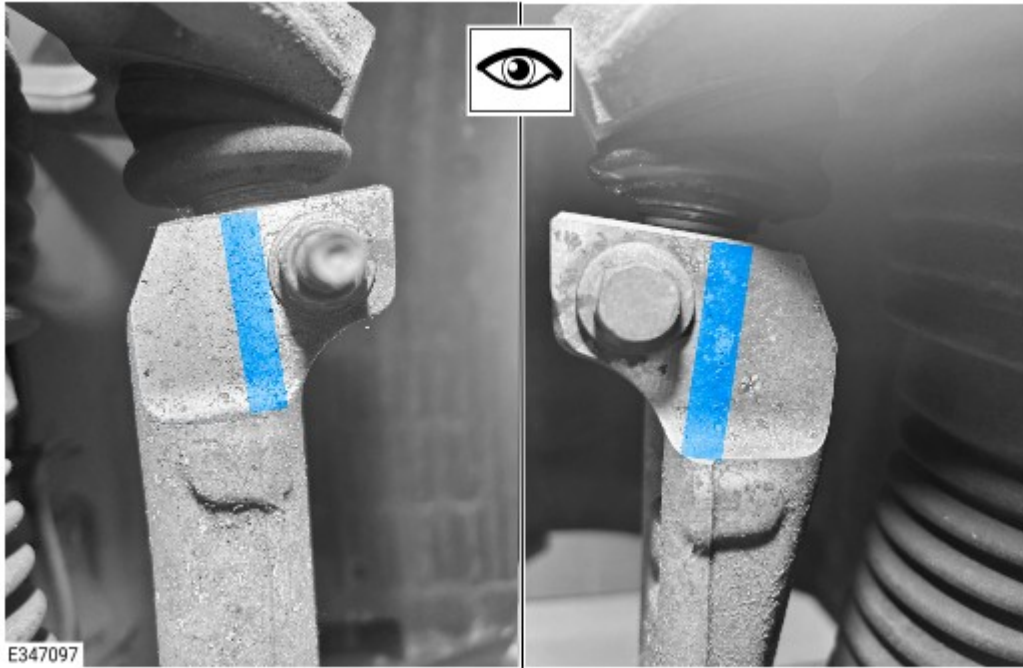

**3.****NOTES:**

- The example illustrations are applicable to both left and right front wheel knuckles.
- Use a suitable flashlight and / or a mirror to assist with the visual inspection.

Examples of front wheel knuckle cracks are shown in the illustrations.

- If cracks **ARE** visible on the front wheel knuckle, the front wheel knuckle has **FAILED** service inspection 3. Replace the front wheel knuckle that has **FAILED** service inspection 3, continue to **FRONT WHEEL KNUCKLE REPLACEMENT**.
- If cracks **ARE NOT** visible on the front knuckle, the knuckle has **PASSED** service inspection 3. **Continue to the FRONT WHEEL KNUCKLE BRACKET INSTALLATION PROCEDURE.**



## FRONT WHEEL KNUCKLE REPLACEMENT

Only complete the Front Wheel Knuckle Replacement for the wheel knuckle(s) that have FAILED Service Inspection 1, FAILED Service Inspection 2 and FAILED Service Inspection 3.

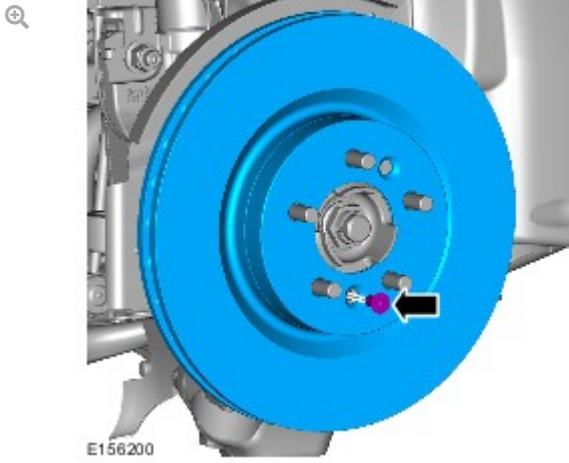

1. Install the front brake disc.

- Install but do not fully tighten the bolt.

Standard brake vehicles only

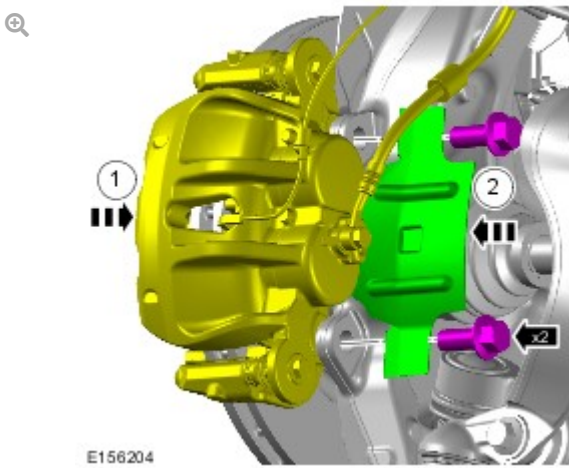

2.

**NOTE:**

Use the front brake caliper bolts retained during step 2 of Service Inspection 2.

Install the front brake caliper.

- Install but do not fully tighten the 2 bolts.

High performance brake vehicles only

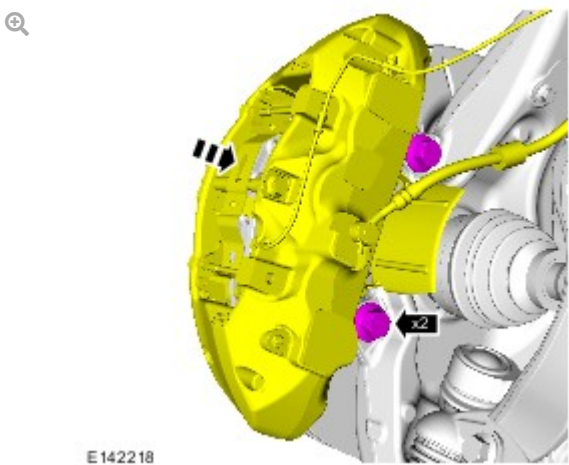

3.

**NOTE:**

Use the front brake caliper bolts retained during step 2 of Service Inspection 2.

Install the front brake caliper.

- Install but do not fully tighten the 2 bolts.

4.

**CAUTION:**

New front brake caliper bolts must be used during this step.

Renew the front wheel knuckle, (see TOPIx Workshop Manual section 204-01: Front Suspension - Removal and Installation - Wheel Knuckle).

5. If both front wheel knuckles **FAILED** Service Inspection 3, repeat steps 1 to 4 for the other side.

## **FRONT KNUCKLE BRACKET INSTALLATION PROCEDURE**

The Front Bracket Installation Procedure **MUST** be completed on front wheel knuckles that **FAILED** Service Inspection 1, **FAILED** Service Inspection 2 and **PASSED** Service Inspection 3.

1. The area of the front knuckle shown highlighted in the illustrations must be clean and free from contamination.

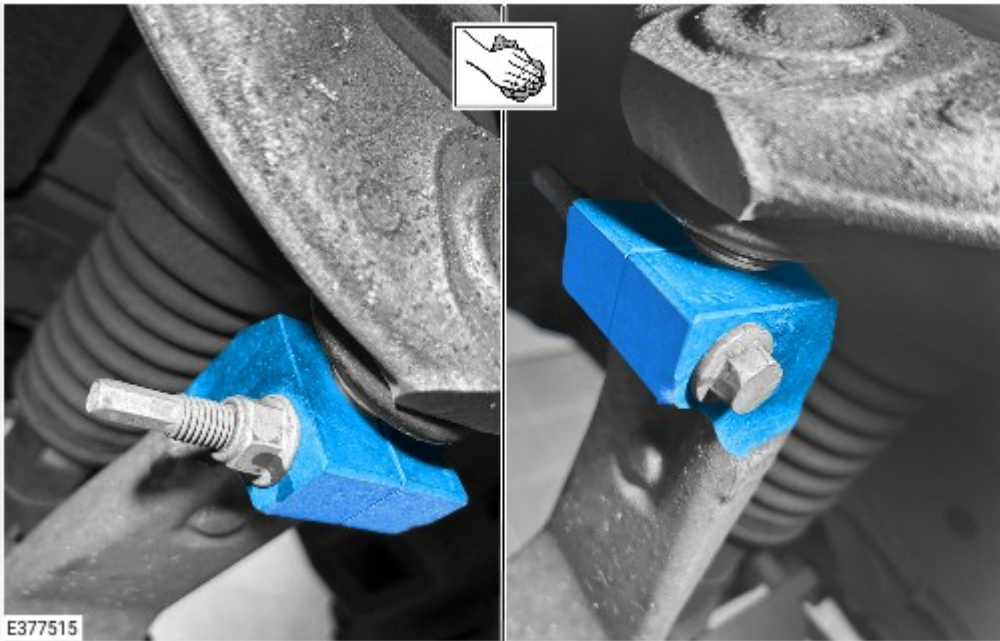
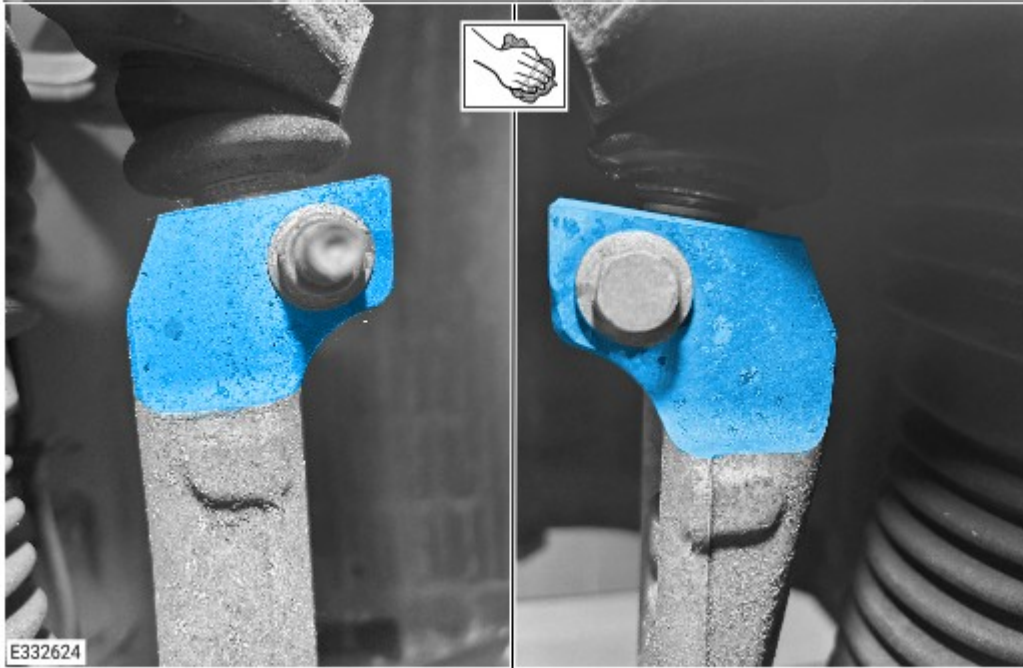

## 2. Install the 2 front knuckle bracket side hooks.

- Apply Loctite© 243 to the bolt.
- Install the bolt, finger tight only at this stage.

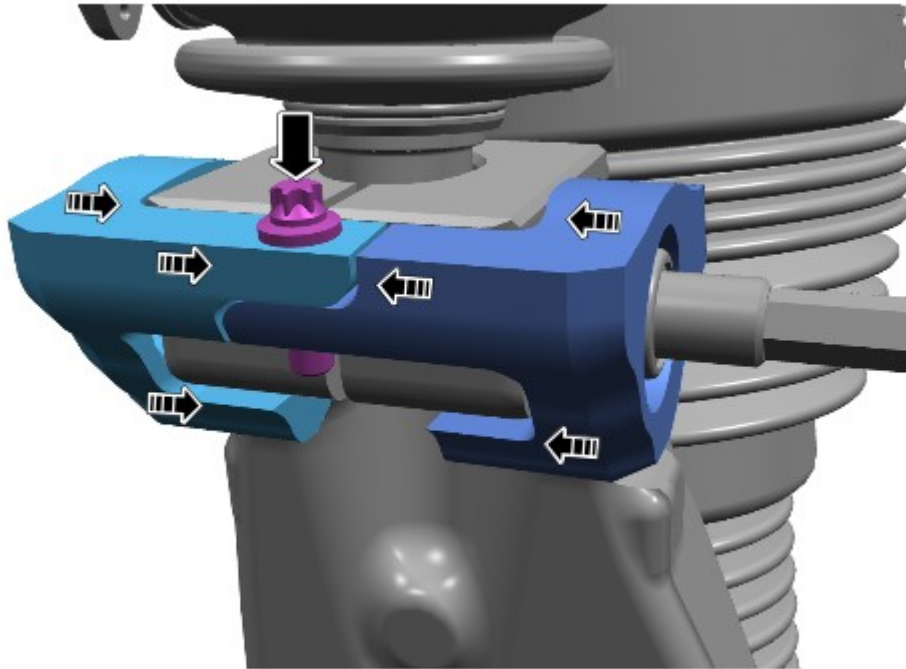

E373427

## 3.

**CAUTION:**

The front knuckle bracket rear plate must be installed with the part number facing outward from the front wheel knuckle.

Install the front knuckle bracket rear plate.

- Apply Loctite© 243 to the 2 bolts.
- Install the 2 bolts, finger tight only at this stage.

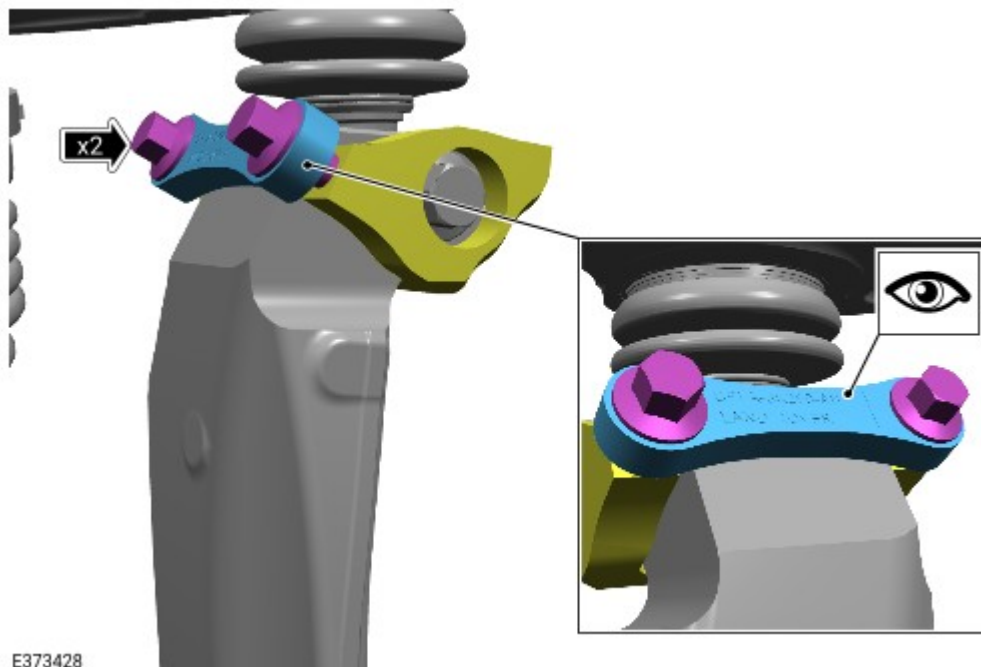

E373428

4. Align the front knuckle bracket to be central to the front knuckle.

- The front knuckle bracket must be centrally aligned to the front wheel knuckle as shown in the illustration with the **GREEN ✓**.
- The front knuckle bracket must not be aligned to the front wheel knuckle as shown in the illustrations with the **RED X**.

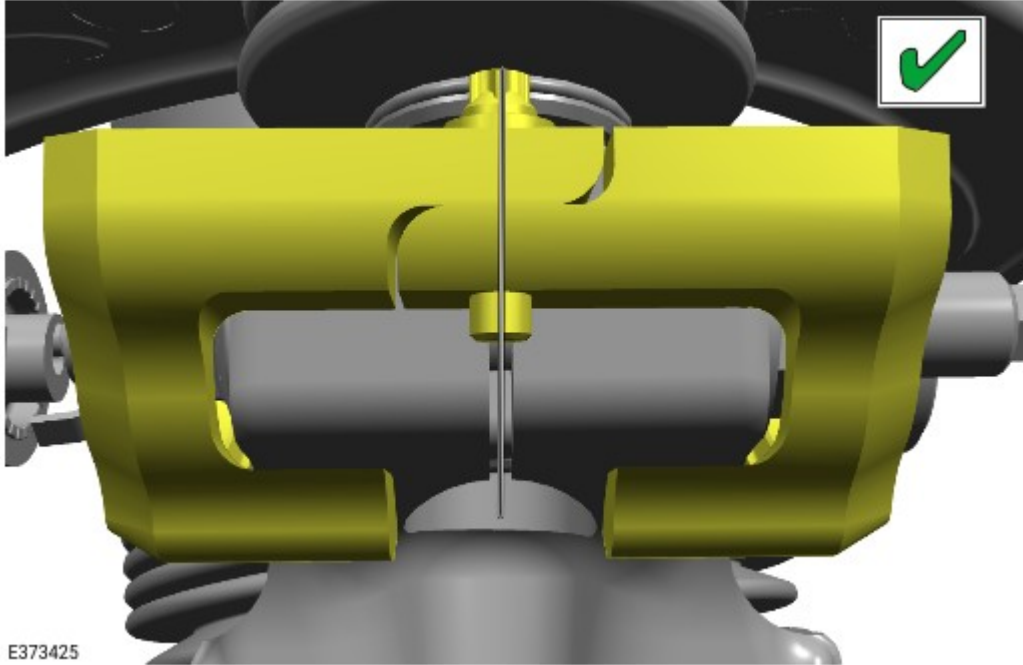

E373425

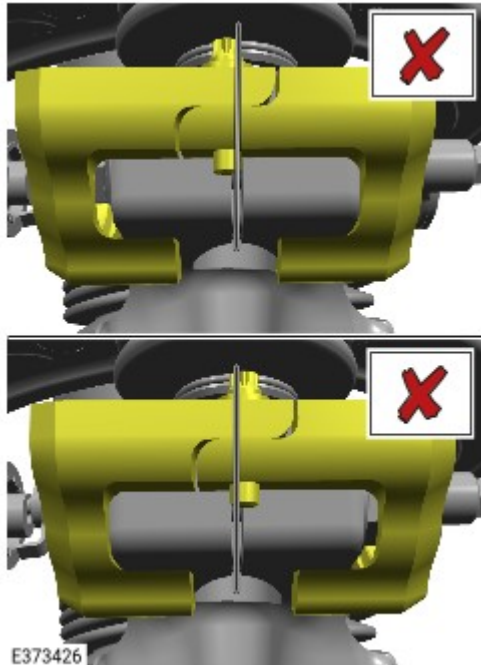

E373426

5.

**CAUTIONS:**

- There must be a gap between the front knuckle bracket rear plate and the 2 front knuckle bracket side hooks.
- The gap between the front knuckle bracket rear plate and the 2 front knuckle bracket side hooks must be maintained both sides of the front knuckle bracket rear plate.
- The front knuckle bracket must remain central to the front knuckle during tightening, as shown in the illustration.
- The M5 bolt torque must be checked after the 2 M8 bolts have been tightened.

Fully tighten the 3 front knuckle bracket bolts.

1. M5 Bolt: **6 Nm**
2. M8 Bolts:
  - Stage 1: **10 Nm**
  - Stage 2: **24 Nm**
3. Re-torque the M5 Bolt: **6 Nm**

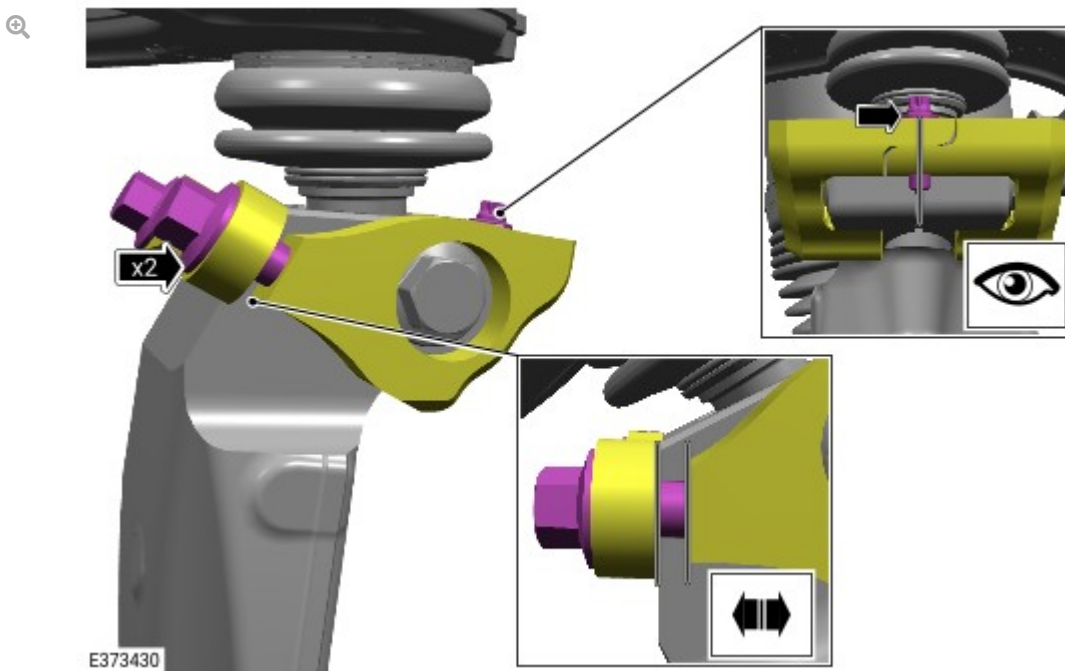

6. Install the front wheel and tire assembly (see TOPIx Workshop Manual section 204-04: Wheels and Tires - Removal and Installation - Wheel and Tire).

7. Repeat steps 1 to 6 for the other side if required.

**SAMPLE CUSTOMER LETTER - FOR INFORMATION ONLY**

Name  
Address line 1  
Address line 2  
Address line 3  
Post Code

Vehicle Identification Number (VIN):  
Registration Number:  
Program Number: D027

Date: month/year

**SAFETY RELATED RECALL - Range Rover - Range Rover (L405) Front Suspension Knuckle Crack**

Dear

JLR would like to advise you that during ongoing quality assessment of our product it has been identified that a possible safety related problem may occur on certain JLR vehicles within a specific production range. Read the information below, explaining the actions that we intend to take and what you are required to do.

**Why are we contacting you?**

A concern has been identified on certain 2015 model year to 2017 model year Range Rover vehicles where the front suspension upper knuckle joint could develop a crack. In extreme cases this may lead to detachment of the upper suspension arm.

In cases where a crack in the front suspension knuckle has developed, the environmental conditions in the markets may lead to a worsening of the crack and an eventual detachment of the upper suspension arm, which under extreme avoidance maneuver use conditions may compromise the vehicle's controllability and increase the risk of a crash.

**What will your JLR retailer / authorized repairer do?**

At your visit, your preferred JLR retailer / authorized repairer will for each of the front suspension knuckles first inspect the part to ascertain if it is an at-risk part supplied by SAI, or a previous level of part which is deemed not to pose a risk. If the latter, no action will be taken for that knuckle. If the part is an SAI-supplied at-risk part, the technician will inspect the suspension knuckle for the presence of any cracks. Where no crack is present and where available, a retaining bracket will be installed to the joint. Where cracks are found or a bracket is not available, the front suspension knuckle will be replaced.

**How long will it take?**

The work on your vehicle will be completed as quickly and efficiently as possible in order to minimize inconvenience to you. Your JLR retailer / authorized repairer will be able to advise how long your vehicle will be required for when a booking is made.

**What we are asking you to do**

Contact your preferred JLR retailer / authorized repairer without delay. To book your vehicle in for this action, you must provide your JLR retailer / authorized repairer with the following details, which are at the beginning of this letter:

- The VIN for your vehicle
- Vehicle registration number of your vehicle.
- The Program Number for the action.

If you do not have a JLR retailer / authorized repairer, access [www.landrover.co.uk](http://www.landrover.co.uk) or [www.landrover.com](http://www.landrover.com) for contact details.

If you no longer own the vehicle, could you complete the 'Change of Ownership' slip attached to this letter, returning the slip to JLR immediately in the enclosed Freepost envelope. This will enable us to make contact and share this information with the new owner.

**If you have concerns**

If you experience any concerns relating to this Recall, contact the Service Manager at the JLR retailer / authorized repairer for assistance or contact the JLR Customer Experience Center on 0345 303 2303 or (enter phone number).

This bulletin is being issued in accordance with the legislative or industry requirements concerning vehicle defects. The authorities will closely monitor the response rate of this bulletin.

Treat this matter with the urgency it requires, JLR apologize for any inconvenience this bulletin may cause and thank you, in advance, for your co-operation.

Yours sincerely

Head of Business

<b>Technical Questions And Answers</b>	
<b>FOR USE ON ENQUIRY</b>	
<b>JLR Recalls N759, D019, D025, D027 and D041</b>	
<b>Range Rover (L405) and Range Rover Sport (L494) Front Suspension Knuckle Crack</b>	

A concern has been identified on certain 2014 model year to 2017 model year Range Rover (L405) and Range Rover Sport (L494) vehicles where the front suspension upper knuckle joint could develop a crack. In extreme cases this may lead to detachment of the upper suspension arm.

### **Question 1**

Why is JLR recalling certain Range Rover and Range Rover Sport models?

*Answer*

JLR is conducting a voluntary recall on certain 2014 model year to 2017 model year Range Rover and Range Rover Sport vehicles. Customers will be asked to take their vehicles to a JLR retailer / authorized repairer to have the front suspension knuckles inspected and replaced or a retaining bracket installed if within the at-risk range.

### **Question 2**

Can you tell me more about what is wrong with the vehicles?

*Answer*

A crack in the front suspension knuckle may propagate which may lead to a detachment of the upper suspension arm. Under an extreme avoidance maneuver use conditions this may compromise the vehicle's controllability and increase the risk of a crash.

### **Question 3**

How would the customer become aware of their vehicle potentially having this concern?

*Answer*

Where a crack starts, knocking noises from the front of the vehicle may be heard. Where the detachment of the suspension arm occurs, it may collide with air suspension spring and other inner fender parts. Steering feel will be impacted as the camber and toe angles of the affected wheel are changed.

### **Question 4**

Has JLR received many complaints?

*Answer*

JLR has received approximately 28 field reports relating to detachment.

### **Question 5**

Does this concern affect vehicle safety?

*Answer*

JLR has determined that in extreme use cases, where a vehicle's controllability is compromised, there is an effect on safety.

### **Question 6**

Are there any precautions that can be taken to minimize the risk until the corrective measures are implemented?

*Answer*

Affected customers will be contacted directly by JLR and are advised to book their vehicles in for repair as soon as possible.

If unusual noises be heard such as knocking from the front of the vehicle, customers are advised to contact a JLR retailer / authorized repairer to have this investigated.

### **Question 7**

Have there been any accidents or injuries or fires?

*Answer*

There have been a small number of reports of accidents, but no reports of injuries or fires as a result of this concern.

**Question 8**

Is the concern leading you to any concerns regarding the reliability of a system, which is supposed to be designed and engineered for the passengers' safety? What type of measures are you planning to take?

*Answer*

JLR has no concerns with the overall reliability of the vehicle. JLR carefully monitors field data to make sure that any matters relating to safety and compliance are rigorously investigated.

**Question 9**

How was the concern discovered?

*Answer*

The concern was discovered through a combination of Government Agency defect investigations, warranty claims and field reports.

**Question 10**

How long has JLR known about this concern?

*Answer*

JLR continuously monitors field data and reports of incidents affecting its vehicles. The recall decisions have been the result of a careful review of this data and engagement with several government authorities.

**Question 11**

What has JLR done in production?

*Answer*

These vehicles are no longer in production.

**Question 12**

What will JLR retailer / authorized repairers do to the vehicles?

*Answer*

Owners will be notified and instructed to take their vehicle to an approved JLR retailer / authorized repairer.

For each of the front suspension knuckles, the technician will first inspect the part to ascertain if it is an at-risk part supplied by SAI, or a previous level of part which is deemed not to pose a risk. If the latter, no action will be taken for that knuckle. If the part is an SAI-supplied at-risk part, the technician will inspect the suspension knuckle for the presence of any cracks. Where no crack is present and where available, a retaining bracket will be installed to the joint. Where cracks are found or a bracket is not available, the front suspension knuckle will be replaced.

Range Rover Sport vehicles will be repaired under JLR campaign reference D019. Range Rover vehicles will be repaired under one of JLR campaign references; N759, D025, D027 or D041 (recall campaign split internally for administration purposes).

There will be no charge to the owners for this repair.

**Question 13**

Which vehicles are affected by this recall?

*Answer*

2014 model year to 2017 model year Range Rover and Range Rover Sport vehicles as below may be affected:

Range Rover SALGA2JF9EA194743 to SALGA2EE0HA320574\*

Range Rover Sport SALWA2VF2EA501059 to SALWA2FK4HA695612\*

\* Specific vehicles within the Vehicle Identification Number (VIN) range

**Question 14**

Are other JLR models affected by this concern?

*Answer*

No other JLR models are affected by this concern.

**Question 15**

Are parts available to rework vehicles?

*Answer*

The recalls will be launched when parts are available in sufficient quantity to fulfil the repair requirements.

**Question 16**

How much will the recall cost JLR?

*Answer*

Cost was not a factor in deciding to recall these vehicles.

**Question 17**

How do I know if my vehicle is affected?

*Answer*

All owners of potentially affected vehicles will shortly be contacted and invited to make an appointment with a JLR retailer / authorized repairer for the work to be completed.

In some countries, recall information is available online through the brand's web site.

Customers can use the Recall Search at <https://TOPIx.landrover.jlrext.com/TOPIx/vehicle/lookupForm>

**Question 18**

How long does it take for the vehicle to be inspected and repaired?

*Answer*

The work will be completed out as quickly and efficiently as possible in order to minimize inconvenience to customers and is expected to take no longer than two hours to complete. Naturally, due to JLR retailer / authorized repairer schedules, vehicles may be required for longer.

*Note:*

Any Press enquiries must be referred to the JLR Public Affairs office