



SAFETY RELATED RECALL

Global Recall Action
Number: N759v8

Changes are highlighted in blue

Subject: Range Rover (L405) Front Suspension Knuckle Crack	Publication No.: N759v8
	Model: Range Rover (LG)
	Model Year: 2014 - 2016
	Date of Issue: 20 February 2026

To:	The National Sales Company (NSC), importers, retailers and authorized repairers in the United Kingdom. Jaguar Land Rover Canada ULC Jaguar Land Rover North America, LLC.
For the Attention of:	The approved JLR retailer / authorized repairer.
Important:	NOTE: The information in this campaign is intended for use by professional technicians. If you are not a JLR retailer / authorized repairer, do not assume that a condition described affects a specific vehicle. Contact an authorized JLR retailer / authorized repairer to determine if this campaign applies to a specific vehicle. This bulletin is being re-issued to update the warranty information.

FOR THE ATTENTION OF ALL:

DESCRIPTION OF ISSUE AND THE EFFECT ON VEHICLE OPERATION

A concern has been identified on certain 2014 model year to 2016 model year Range Rover vehicles where the front suspension upper knuckle joint could develop a crack. In extreme cases where a crack in the front suspension knuckle has developed, this may lead to detachment of the upper suspension arm, which under extreme avoidance maneuver use conditions may compromise the vehicle's controllability and increase the risk of a crash.

N759 Recall bulletins published in Canada and the UK markets and Recall Administration bulletin N759ADM1 in the USA announced all affected vehicles were being recalled under campaign N759. In July 2025, for administrative purposes it was decided to split the recall populations, whereby they will be managed and remedied under N759 and in additional several incremental campaigns to be communicated in separate bulletins. The remedy remains unchanged for all vehicles and this is an internal administration simplification step only.

ACTION TO BE TAKEN

JLR has taken the decision to recall affected vehicles to repair the vehicle.

Following procedures appropriate to your market and as required by local legislation, owners of affected vehicles must be contacted requesting that the owner contact their nearest JLR retailer / authorized repairer as soon as possible to arrange for the repair to be completed. The National Sales Company (NSC), Importer, Regional Office or Government agency will contact the customers. If you have any questions about this process, contact your NSC / Importer or Regional Office for more information.

Check the JLR Warranty Portal to make sure affected vehicles are correctly identified prior to starting this campaign. The Warranty Portal will be updated to reflect only those vehicles affected.

JLR retailers / authorized repairers are reminded that they must not sell vehicles identified as affected by this campaign until such time as the repair has been successfully completed.

An owner may indicate that a repair has already been completed for this concern, in which case the full cost of the repair should be reimbursed. Refer to the warranty section of this campaign for details of the Customer Reimbursement and Related Damage Process. At the time of confirming a booking for a vehicle repair, make sure you check the Warranty Portal to confirm if there are any other outstanding campaigns, to make sure the correct parts are available and adequate workshop time is allocated for repairs to be completed in one visit.

For information purposes, a Technical Question and Answer document is attached.

FOR THE ATTENTION OF NORTH AMERICAN TERRITORIES ONLY:

Transport Canada (TC) reference number: 2022-668

National Highway Traffic Safety Administration (NHTSA) reference number: 25V-514

Visit the British Brands Sales Suite (BBSS) website for a list of affected vehicles at your JLR retailer / authorized repairer. Unsold vehicles must be repaired prior to handover of the vehicle for retail sale.

FOR THE ATTENTION OF NORTH AMERICAN TERRITORIES ONLY:

REGULATORY INFORMATION

Jaguar Land Rover North America, LLC and Jaguar Land Rover Canada ULC have informed the National Highway Traffic Safety Administration (NHTSA) and Transport Canada (TC) of their intent to perform a Safety Recall on certain 2014 model year to 2016 model year Range Rover vehicles imported into the United States and Canadian markets. Information relating to this Safety Recall will be posted on the NHTSA and TC websites. United States Federal regulations require that JLR retailers / authorized repairers must be notified within a reasonable time after the manufacturer decides that a defect that relates to motor vehicle safety or a non-compliance exists. United States Federal Law requires JLR retailers / authorized repairers to complete any outstanding Safety Recall before a new vehicle is delivered to the buyer or lessee. Violation of this requirement by a JLR retailers / authorized repairers, in the USA only, could result in a maximum civil penalty of up to the equivalent of \$27,168.00 USD per violation and the equivalent of \$135,828,178.00 USD for a related series of violations. This Safety Recall serves as notification to all JLR retailers / authorized repairers in the United States and Federalized Territories and Canada that any affected new vehicles may not be sold and delivered for customer use until the Safety Recall repair is completed.

Jaguar Land Rover North America, LLC and Jaguar Land Rover Canada ULC recommends that affected sales demonstrator and loaner vehicles are repaired before use, and that used vehicles are repaired before sale. JLR retailers / authorized repairers who proceed against this recommendation, where legally permitted, must clearly and conspicuously disclose the open Safety Recall notice to the applicable customers.

Yours faithfully

Steve Oldham

Global Customer Care Quality Director

SERVICE INSTRUCTION**- N759V8**

Changes are highlighted in blue

Parts Information**NOTES:**

- *An allowance equivalent to £1.00 Sterling has been allocated to locally source Loctite© 243.
- **An allowance equivalent to £0.10 Sterling has been allocated to locally source a suitable paint pen.
- 1 paint pen will be sufficient to cover 50 vehicles.

Description	Part Number/Sundry Code	Qty/£ value	% vehicles requiring parts
Front knuckle - Right	LR146341	1	50
Front knuckle - Left	LR146343	1	50
Front knuckle bolt - M10x70mm	KYG000230	2	50
Front knuckle nut - M10	FY110056	2	50
Front knuckle nut - M16	LR034221	4	50
Hub nut - M24x2.0mm	LR024151	2	50
Caliper bolt - M16x40mm	LR033274	4	50
Tie-rod nut	LR026275	2	50
Front knuckle bracket	602123505	2	50
Loctite© 243	*ZZZ999	£1.00	50
Paint pen	**ZZZ999	£0.10	50

When ordering parts, order no more than the expected percentage failure rate of parts identified.

SROs

Description	SRO	Time
Complete Service Inspection 1	05.10.10	0.1
Complete Service Inspection 2 - Single	99.03.66	0.5
Complete Service Inspection 2 - Pair	99.03.63	1
Complete Service Inspection 3 - Single	99.03.68	0.2
Complete Service Inspection 3 - Pair	99.03.67	0.4

Description	SRO	Time
Install 1 bracket	05.10.20	0.2
Install 2 brackets	05.10.40	0.4
Renew 1 knuckle	05.10.90	0.9
Renew 2 knuckles	05.11.17	1.7
Drive in / drive out	02.02.02	0.2

NOTE:

Repair procedures are under constant review, and therefore times are subject to change; those quoted here must be taken as guidance only. Always refer to TOPIx to obtain the latest repair time.

Warranty Information

Warranty claims must be submitted quoting program code N759 with the relevant option code from the table below. As option codes are used there is no requirement for you to enter SROs or parts, these are included for information only.

Program	Option	Description	SRO	Time	Part Number / Sundry Code	Qty / £ Value
N759	AA	Complete Service Inspection 1	05.10.10	0.1	N/A	N/A
N759	AB	Complete Service Inspection 1 Drive in / drive out	05.10.10 02.02.02	0.1 0.2	N/A	N/A
N759	AC	Complete Service Inspection 1 Complete Service Inspection 2 - Single	05.10.10 99.03.66	0.1 0.5	LR033274 **ZZZ999	2 £0.10
N759	AD	Complete Service Inspection 1 Complete Service Inspection 2 - Single Drive in / drive out	05.10.10 99.03.66 02.02.02	0.1 0.5 0.2	LR033274 **ZZZ999	2 £0.10
N759	BB	Complete Service Inspection 1 Complete Service Inspection 2 - Pair	05.10.10 99.03.63	0.1 1	LR033274 **ZZZ999	4 £0.10
N759	BC	Complete Service Inspection 1 Complete Service Inspection 2 - Pair Drive in / drive out	05.10.10 99.03.63 02.02.02	0.1 1 0.2	LR033274 **ZZZ999	4 £0.10
N759	AE	Complete Service Inspection 1 Complete Service Inspection 2 - Single Complete Service Inspection 3 - Single Install 1 bracket	05.10.10 99.03.66 99.03.68 05.10.20	0.1 0.5 0.2 0.2	LR033274 602123505 *ZZZ999 **ZZZ999	2 1 £1.00 £0.10
N759	AF	Complete Service Inspection 1 Complete Service Inspection 2 - Single Complete Service Inspection 3 - Single Install 1 bracket Drive in / drive out	05.10.10 99.03.66 99.03.68 05.10.20 02.02.02	0.1 0.5 0.2 0.2 0.2	LR033274 602123505 *ZZZ999 **ZZZ999	2 1 £1.00 £0.10
N759	AG	Complete Service Inspection 1 Complete Service Inspection 2 - Single Complete Service Inspection 3 - Single Renew left knuckle	05.10.10 99.03.66 99.03.68 05.10.90	0.1 0.5 0.2 0.9	LR146343 KYG000230 FY110056 LR024151 LR033274 LR034221 LR026275 **ZZZ999	1 1 1 1 2 2 1 £0.10

Program	Option	Description	SRO	Time	Part Number / Sundry Code	Qty / £ Value
N759	AH	Complete Service Inspection 1	05.10.10	0.1	LR146343	1
		Complete Service Inspection 2 - Single	99.03.66	0.5	KYG000230	1
		Complete Service Inspection 3 - Single	99.03.68	0.2	FY110056	1
		Renew left knuckle	05.10.90	0.9	LR024151	1
		Drive in / drive out	02.02.02	0.2	LR033274	2
					LR034221	2
					LR026275	1
			**ZZZ999	£0.10		
N759	AI	Complete Service Inspection 1	05.10.10	0.1	LR146341	1
		Complete Service Inspection 2 - Single	99.03.66	0.5	KYG000230	1
		Complete Service Inspection 3 - Single	99.03.68	0.2	FY110056	1
		Renew right knuckle	05.10.90	0.9	LR024151	1
					LR033274	2
					LR034221	2
					LR026275	1
			**ZZZ999	£0.10		
N759	AJ	Complete Service Inspection 1	05.10.10	0.1	LR146341	1
		Complete Service Inspection 2 - Single	99.03.66	0.5	KYG000230	1
		Complete Service Inspection 3 - Single	99.03.68	0.2	FY110056	1
		Renew right knuckle	05.10.90	0.9	LR024151	1
		Drive in / drive out	02.02.02	0.2	LR033274	2
					LR034221	2
					LR026275	1
			**ZZZ999	£0.10		
N759	AK	Complete Service Inspection 1	05.10.10	0.1	LR033274	4
		Complete Service Inspection 2 - Pair	99.03.63	1	602123505	1
		Complete Service Inspection 3 - Single	99.03.68	0.2	*ZZZ999	£1.00
		Install 1 bracket	05.10.20	0.2	**ZZZ999	£0.10
N759	AL	Complete Service Inspection 1	05.10.10	0.1	LR033274	4
		Complete Service Inspection 2 - Pair	99.03.63	1	602123505	1
		Complete Service Inspection 3 - Single	99.03.68	0.2	*ZZZ999	£1.00
		Install 1 bracket	05.10.20	0.2	**ZZZ999	£0.10
		Drive in / drive out	02.02.02	0.2		
N759	AM	Complete Service Inspection 1	05.10.10	0.1	LR146343	1
		Complete Service Inspection 2 - Pair	99.03.63	1	KYG000230	1
		Complete Service Inspection 3 - Single	99.03.68	0.2	FY110056	1
		Renew left knuckle	05.10.90	0.9	LR024151	1
					LR033274	4
					LR034221	2
			LR026275	1		
			**ZZZ999	£0.10		
N759	AN	Complete Service Inspection 1	05.10.10	0.1	LR146343	1
		Complete Service Inspection 2 - Pair	99.03.63	1	KYG000230	1
		Complete Service Inspection 3 - Single	99.03.68	0.2	FY110056	1
		Renew left knuckle	05.10.90	0.9	LR024151	1
		Drive in / drive out	02.02.02	0.2	LR033274	4
					LR034221	2
					LR026275	1
			**ZZZ999	£0.10		
N759	AP	Complete Service Inspection 1	05.10.10	0.1	LR146341	1
		Complete Service Inspection 2 - Pair	99.03.63	1	KYG000230	1
		Complete Service Inspection 3 - Single	99.03.68	0.2	FY110056	1
		Install right knuckle	05.10.90	0.9	LR024151	1
					LR033274	4

Program	Option	Description	SRO	Time	Part Number / Sundry Code	Qty / £ Value
					LR034221 LR026275 **ZZZ999	2 1 £0.10
N759	AR	Complete Service Inspection 1 Complete Service Inspection 2 - Pair Complete Service Inspection 3 - Single Install right knuckle Drive in / drive out	05.10.10 99.03.63 99.03.68 05.10.90 02.02.02	0.1 1 0.2 0.9 0.2	LR146341 KYG000230 FY110056 LR024151 LR033274 LR034221 LR026275 **ZZZ999	1 1 1 1 4 2 1 £0.10
N759	AS	Complete Service Inspection 1 Complete Service Inspection 2 - Pair Complete Service Inspection 3 - Pair Install 2 brackets	05.10.10 99.03.63 99.03.67 05.10.40	0.1 1 0.4 0.4	LR033274 602123505 *ZZZ999 **ZZZ999	4 2 £1.00 £0.10
N759	AT	Complete Service Inspection 1 Complete Service Inspection 2 - Pair Complete Service Inspection 3 - Pair Install 2 brackets Drive in / drive out	05.10.10 99.03.63 99.03.67 05.10.40 02.02.02	0.1 1 0.4 0.4 0.2	LR033274 602123505 *ZZZ999 **ZZZ999	4 2 £1.00 £0.10
N759	AU	Complete Service Inspection 1 Complete Service Inspection 2 - Pair Complete Service Inspection 3 - Pair Renew left knuckle Install right bracket	05.10.10 99.03.63 99.03.67 05.10.90 05.10.20	0.1 1 0.4 0.9 0.2	LR146343 KYG000230 FY110056 LR024151 LR033274 LR034221 LR026275 602123505 *ZZZ999 **ZZZ999	1 1 1 1 4 2 1 1 £1.00 £0.10
N759	AV	Complete Service Inspection 1 Complete Service Inspection 2 - Pair Complete Service Inspection 3 - Pair Renew left knuckle Install right bracket Drive in / drive out	05.10.10 99.03.63 99.03.67 05.10.90 05.10.20 02.02.02	0.1 1 0.4 0.9 0.2 0.2	LR146343 KYG000230 FY110056 LR024151 LR033274 LR034221 LR026275 602123505 *ZZZ999 **ZZZ999	1 1 1 1 4 2 1 1 £1.00 £0.10
N759	AX	Complete Service Inspection 1 Complete Service Inspection 2 - Pair Complete Service Inspection 3 - Pair Renew right knuckle Install left bracket	05.10.10 99.03.63 99.03.67 05.10.90 05.10.20	0.1 1 0.4 0.9 0.2	LR146341 KYG000230 FY110056 LR024151 LR033274 LR034221 LR026275 602123505 *ZZZ999 **ZZZ999	1 1 1 1 4 2 1 1 £1.00 £0.10
N759	AY	Complete Service Inspection 1 Complete Service Inspection 2 - Pair Complete Service Inspection 3 - Pair Renew right knuckle	05.10.10 99.03.63 99.03.67 05.10.90	0.1 1 0.4 0.9	LR146341 KYG000230 FY110056 LR024151	1 1 1 1

Program	Option	Description	SRO	Time	Part Number / Sundry Code	Qty / £ Value
		Install left bracket	05.10.20	0.2	LR033274	4
		Drive in / drive out	02.02.02	0.2	LR034221	2
					LR026275	1
					602123505	1
					*ZZZ999	£1.00
					**ZZZ999	£0.10
N759	AZ	Complete Service Inspection 1	05.10.10	0.1	LR146341	1
		Complete Service Inspection 2 - Pair	99.03.63	1	LR146343	1
		Complete Service Inspection 3 - Pair	99.03.67	0.4	KYG000230	2
		Renew 2 knuckles	05.11.17	1.7	FY110056	2
					LR024151	2
					LR033274	4
					LR034221	4
					LR026275	2
					**ZZZ999	£0.10
N759	BA	Complete Service Inspection 1	05.10.10	0.1	LR146341	1
		Complete Service Inspection 2 - Pair	99.03.63	1	LR146343	1
		Complete Service Inspection 3 - Pair	99.03.67	0.4	KYG000230	2
		Renew 2 knuckles	05.11.17	1.7	FY110056	2
		Drive in / drive out	02.02.02	0.2	LR024151	2
					LR033274	4
					LR034221	4
					LR026275	2
					**ZZZ999	£0.10

NOTE:

The option that contains the drive in / drive out allowance may only be claimed when the vehicle has been brought back into the workshop for this action alone to be undertaken.

Warranty claims must be submitted in accordance with the current JLR Global Warranty Manual, and its amendments, unless stated otherwise in this campaign.

Customer Reimbursement and Related Damage Process**NOTE:**

If there is a requirement to claim for related / consequential damage or customer reimbursement, refer to the related instruction that can be found in TOPIx (in the Search box, search for 'Related Damage Claim' and open the related bulletin link).

Table of Contents
[REMOVAL AND INSTALLATION: SERVICE INFORMATION](#)
[REMOVAL AND INSTALLATION: SERVICE INSPECTION 1](#)
[REMOVAL AND INSTALLATION: SERVICE INSPECTION 2](#)
[REMOVAL AND INSTALLATION: SERVICE INSPECTION 3](#)
[REMOVAL AND INSTALLATION: FRONT WHEEL KNUCKLE REPLACEMENT](#)
[REMOVAL AND INSTALLATION: FRONT KNUCKLE BRACKET INSTALLATION PROCEDURE](#)
SERVICE INFORMATION

1. The illustration shows the front knuckle bracket components.

1. Front knuckle bracket side hooks.
2. Front knuckle bracket side hooks bolt.
3. Front knuckle bracket rear plate.
4. Front knuckle bracket rear plate bolts.

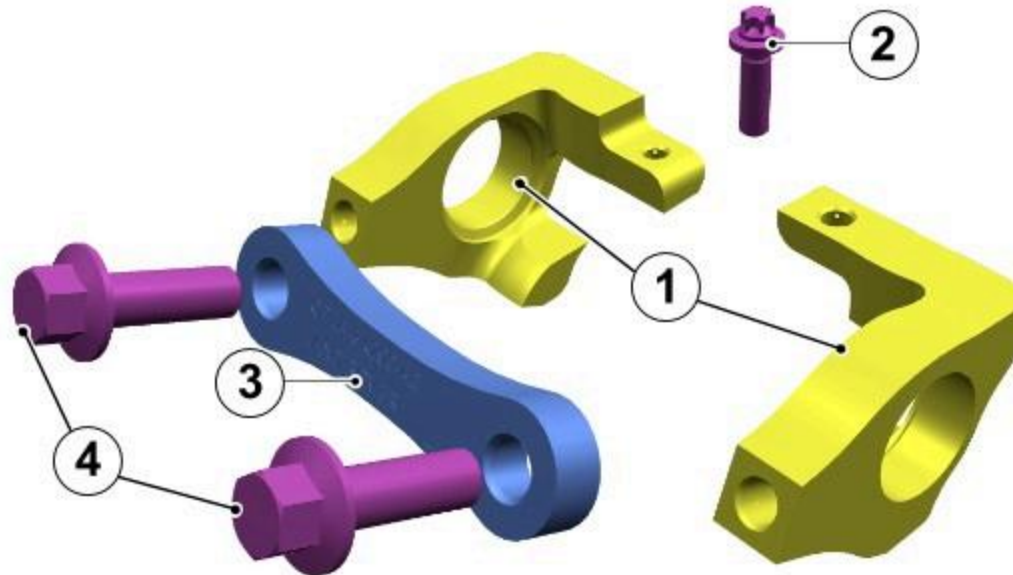

E377524

SERVICE INSPECTION 1

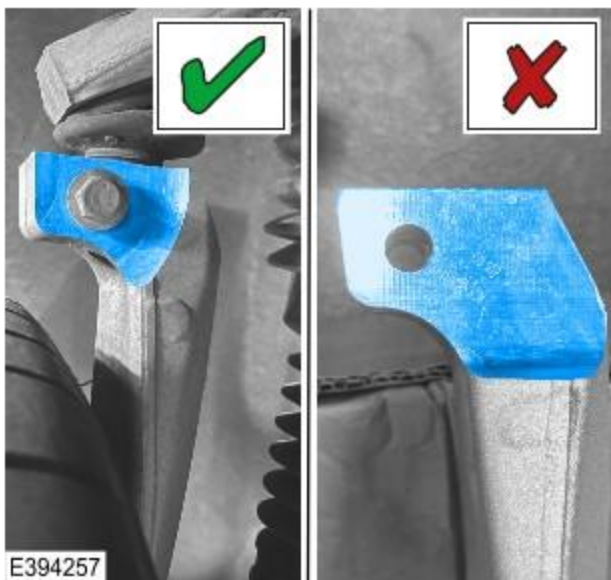

<p class="bold">Service instruction</p>

1.

CAUTIONS:

- The vehicle may have either type of front wheel knuckle installed, both types of front wheel knuckles could be installed on the vehicle.
- Both front wheel knuckles must be inspected. The vehicle may have a different type of front wheel knuckle installed on the left side to the right side.

Inspect the front right wheel knuckle.

- If the front right wheel knuckle is the type shown in the illustration with the **GREEN ✓**, it has **PASSED** service inspection 1. No further action is required for the front right wheel knuckle, **continue to the next step**.
- If the front right wheel knuckle is the type shown in the illustration with the **RED X**, it has **FAILED** service inspection 1. **Continue to the next step**.

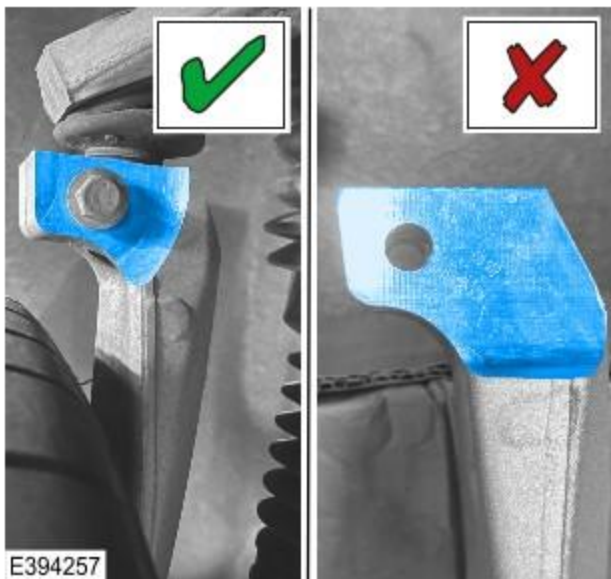

2.

CAUTIONS:

- The vehicle may have either type of front wheel knuckle installed, both types of front wheel knuckles could be installed on the vehicle.
- Both front wheel knuckles must be inspected. The vehicle may have a different type of front wheel knuckle installed on the left side to the right side.

Inspect the front left wheel knuckle.

- If the front left wheel knuckle is the type shown in the illustration with the **GREEN ✓**, it has **PASSED** service inspection 1. No further action is required for the front left wheel knuckle, **continue to the next step**.
- If the front left wheel knuckle is the type shown in the illustration with the **RED X**, it has **FAILED** service inspection 1. **Continue to the next step**.

<p class="bold">Service instruction</p>

3.

NOTE:

If both front knuckles are not affected and the vehicle is released, claim option code AA or option code AB from the warranty information table.

Service inspection 1 results:

- If both the front left and front right wheel knuckles **PASSED** Service inspection 1, **do not continue with this campaign and release the vehicle.**
- If both the front left and front right wheel knuckles **FAILED** Service inspection 1, **complete Service inspection 2 for both the front left and front right wheel knuckles.**
- If the front left wheel knuckle **PASSED** Service inspection 1 and the front right wheel knuckle **FAILED** service inspection 1, **complete Service inspection 2 for the front right wheel knuckle ONLY.**
- If the front right wheel knuckle **PASSED** Service inspection 1 and the front left wheel knuckle **FAILED** service inspection 1, **complete Service inspection 2 for the front left wheel knuckle ONLY.**

SERVICE INSPECTION 2

Only complete Service Inspection 2 for the wheel knuckle(s) that have **FAILED** Service Inspection 1.

1. Raise and support the vehicle on a suitable 2-post lift, (see TOPlx Workshop Manual section 100-02: Jacking and Lifting - Description and Operation).

2.

NOTE:

Do not discard the front brake caliper bolts during this step.

Remove the front brake disc (see TOPlx Workshop Manual section 206-03: Front Disc Brake - Removal and Installation - Brake Disc).

3. Using a suitable method, clean the area highlighted in the illustration.

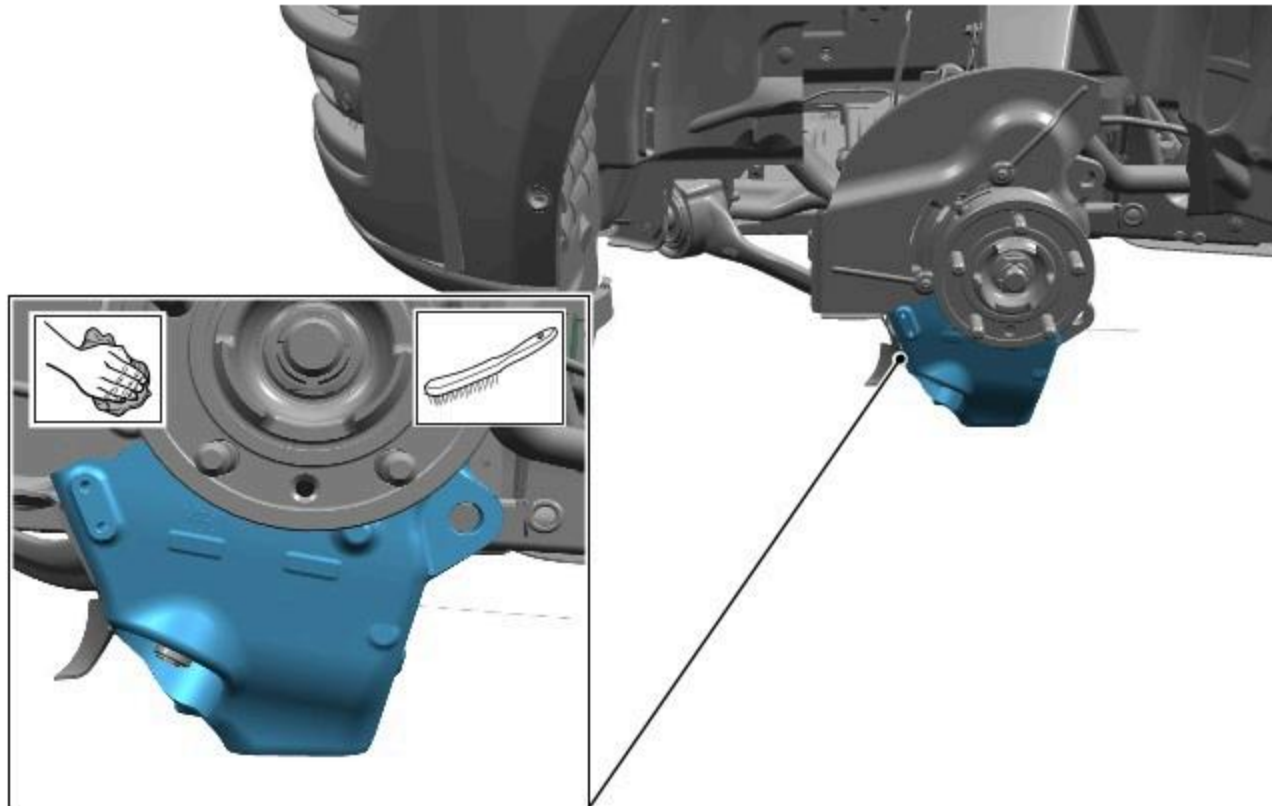

E405754

<p class="bold">Service instruction</p>

4. Using a paint pen, apply paint to the front wheel knuckle part number. The part number will be in the location shown in the illustration, on every front wheel knuckle.
 - Using a suitable cloth, remove excess paint from the part number.



E405755

<p class="bold">Service instruction</p>

5.

NOTE:

Shining a flashlight on the front wheel knuckle part number from above makes inspecting the front wheel knuckle part number easier.

Inspect the front wheel knuckle part number.

- If the front wheel knuckle part number is any of the following part numbers, the front wheel knuckle **has FAILED** Service Inspection 2, **continue to step 7**.
 - **CPLA-3K185-BA, CPLA-3K186-BA, DPLA-3K185-BA or DPLA-3K186-BA.**
- If the front wheel knuckle part number is any of the following part numbers, the front wheel knuckle **has PASSED** Service Inspection 2, **continue to step 6**.
 - **CPLA-3K185-BB, CPLA-3K186-BB or a suffix that starts with an A (xxxx-xxxx-Ax).**



E405756

<p class="bold">Service instruction</p>

6.

CAUTIONS:

- Discard the front brake caliper bolts retained during step 2.
- New front brake caliper bolts must be used during this step.

NOTE:

The front wheel knuckle(s) that have **PASSED** Service Instruction 2 do not require further action.

Install the front brake disc (see TOPIx Workshop Manual section 206-03: Front Disc Brake - Removal and Installation - Brake Disc).

7. If both front wheel knuckles **FAILED** Service Inspection 1, repeat steps 2 to 5 for the other side.

8. Continue to SERVICE INSPECTION 3.

SERVICE INSPECTION 3

Only complete Service Inspection 3 for the wheel knuckle(s) that have **FAILED** Service Inspection 1 and **FAILED** Service Inspection 2.

<p class="bold">Service instruction</p>

1. Use a non abrasive cloth and suitable cleaning fluid to clean the area of the front wheel knuckle shown highlighted in the illustrations.

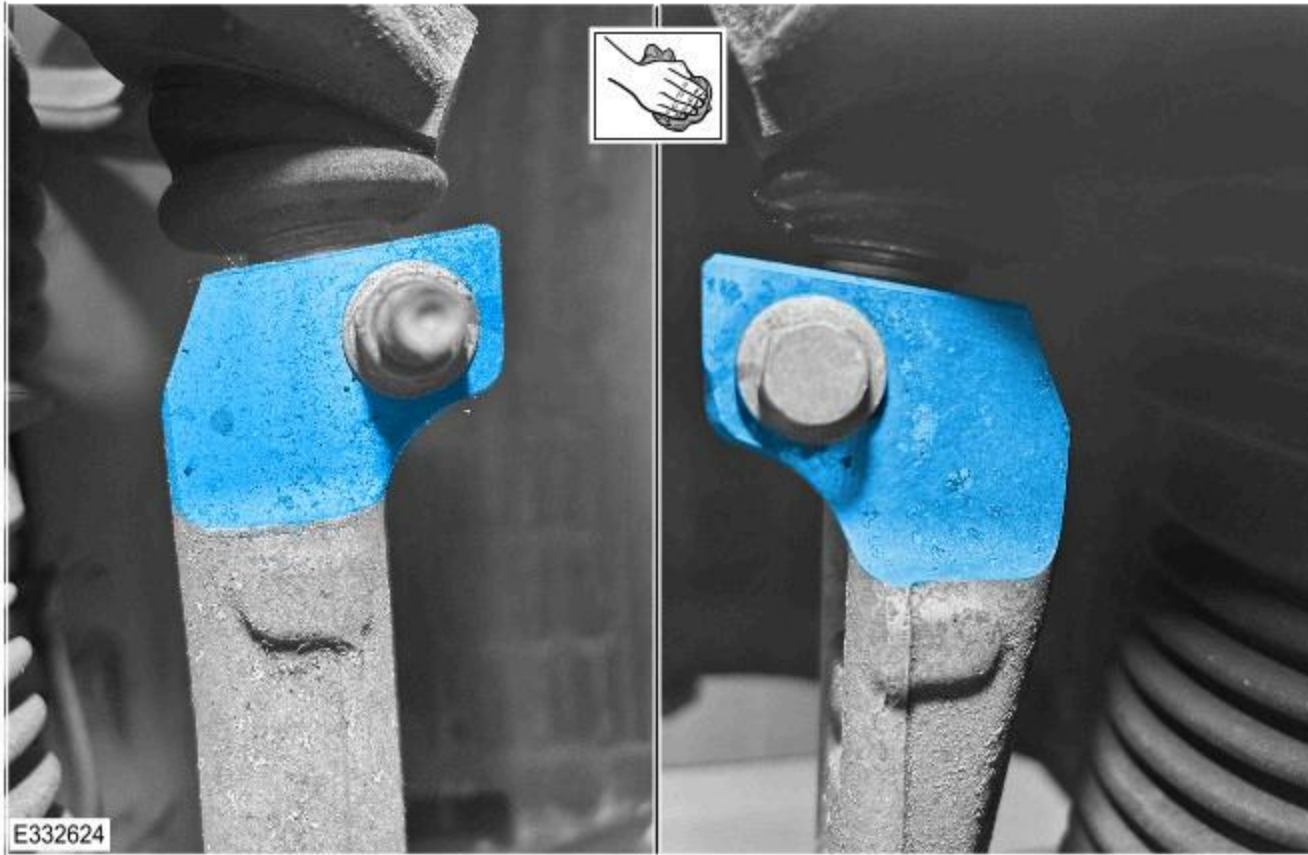



<p class="bold">Service instruction</p>

2. Carefully inspect the front wheel knuckle for visible cracks. Examples of cracks are shown in the next step.

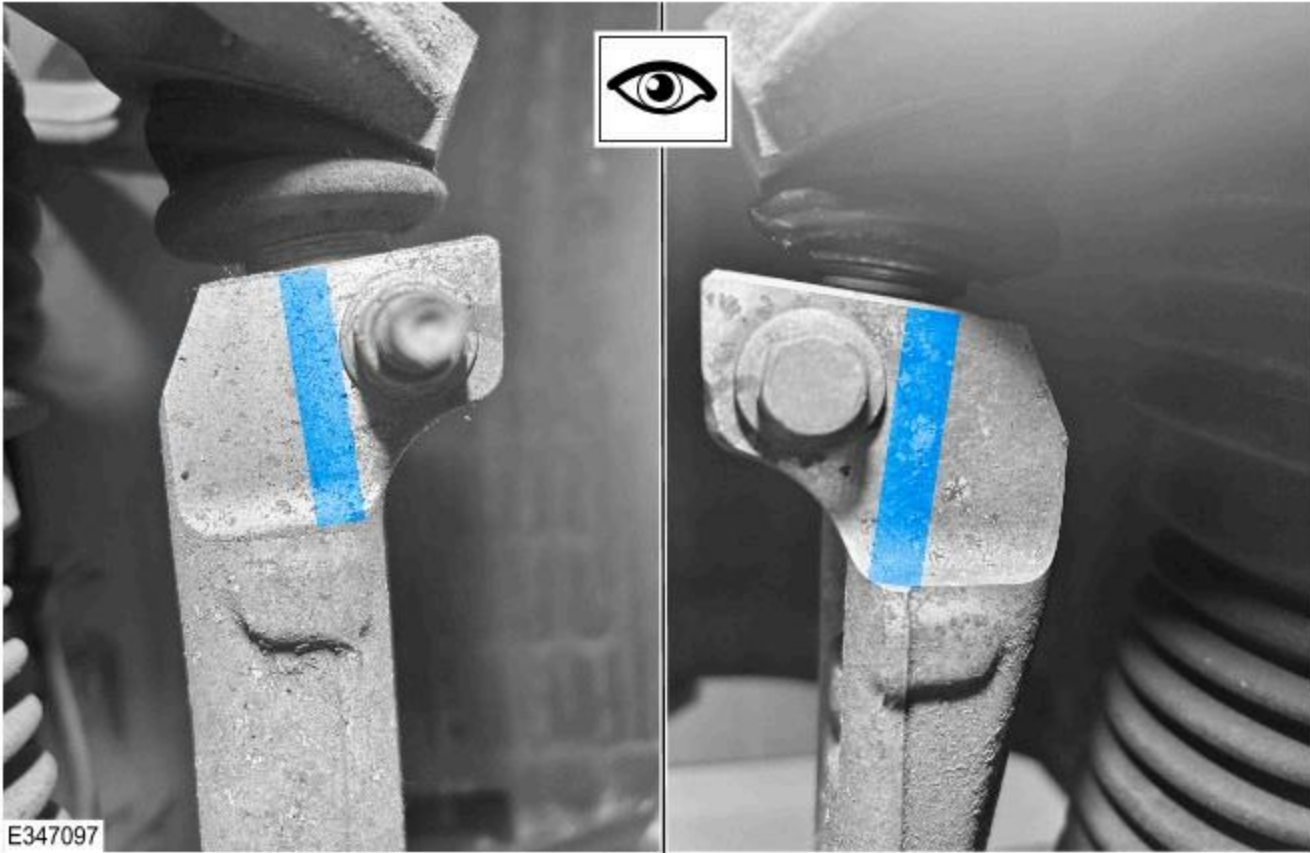

E347097

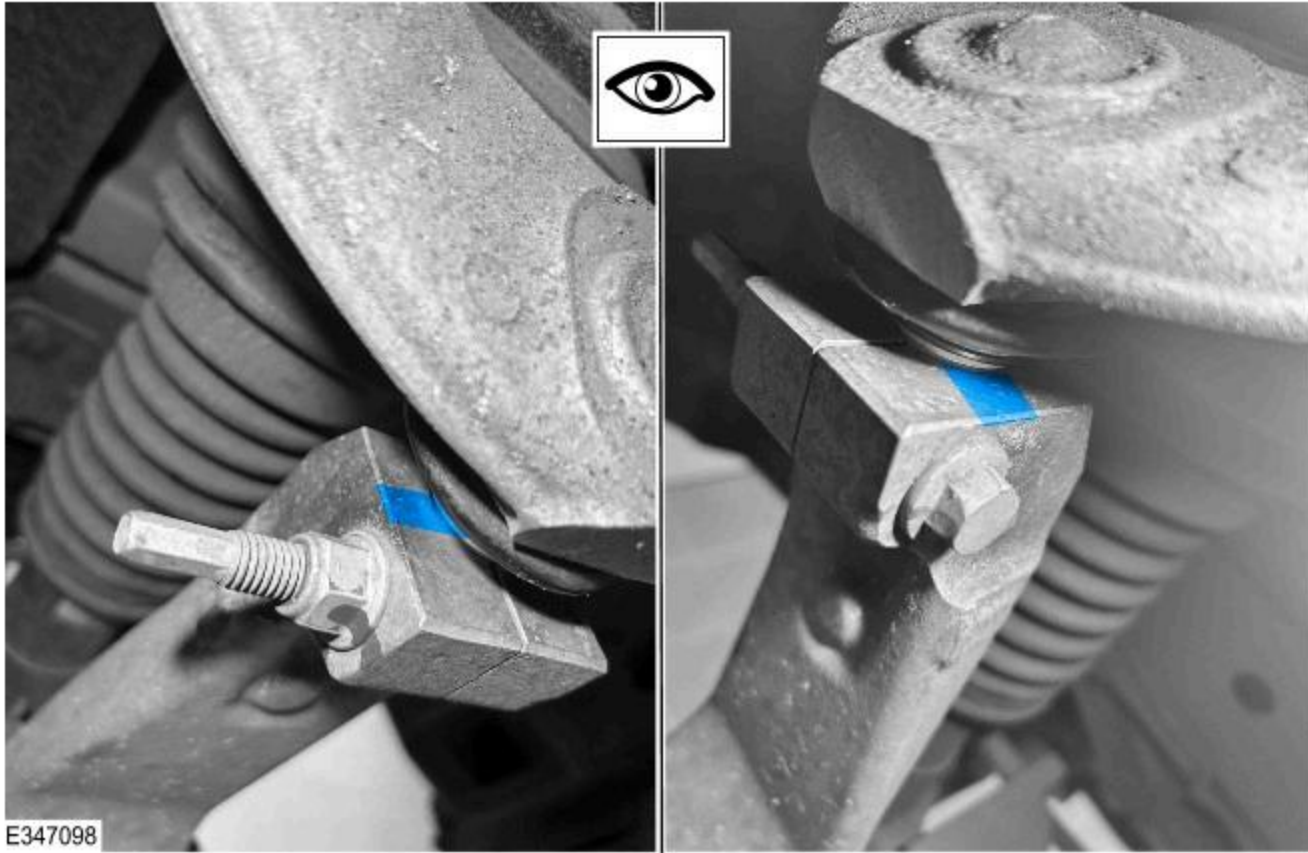

E347098

3.

NOTES:

- The example illustrations are applicable to both left and right front wheel knuckles.
- Use a suitable flashlight and / or a mirror to assist with the visual inspection.

Examples of front wheel knuckle cracks are shown in the illustrations.

- If cracks **ARE** visible on the front wheel knuckle, the front wheel knuckle has **FAILED** service inspection 3. Replace the front wheel knuckle that has **FAILED** service inspection 3, continue to **FRONT WHEEL KNUCKLE REPLACEMENT**.
- If cracks **ARE NOT** visible on the front knuckle, the knuckle has **PASSED** service inspection 3. **Continue to the FRONT WHEEL KNUCKLE BRACKET INSTALLATION PROCEDURE.**





E332627

FRONT WHEEL KNUCKLE REPLACEMENT

Only complete the Front Wheel Knuckle Replacement for the wheel knuckle(s) that have FAILED Service Inspection 1, FAILED Service Inspection 2 and FAILED Service Inspection 3.

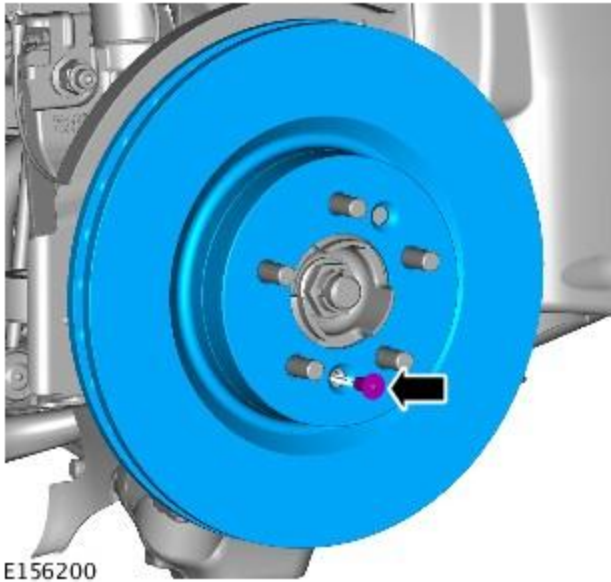

1. Install the front brake disc.
 - Install but do not fully tighten the bolt.

Standard brake vehicles only

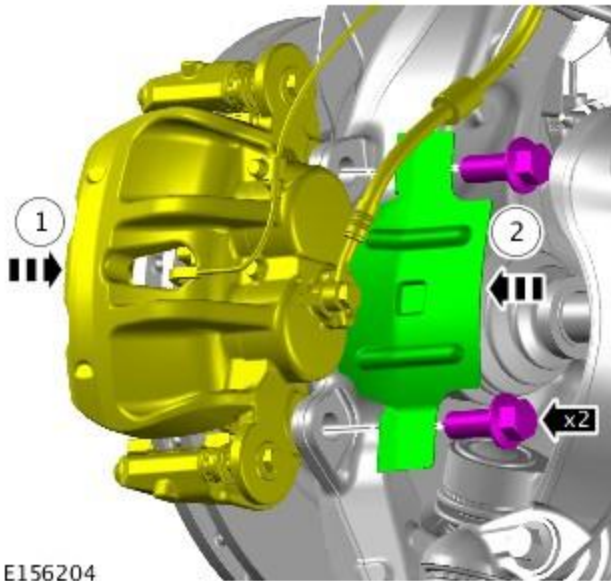

2.

NOTE:

Use the front brake caliper bolts retained during step 2 of Service Inspection 2.

Install the front brake caliper.

- Install but do not fully tighten the 2 bolts.

High performance brake vehicles only

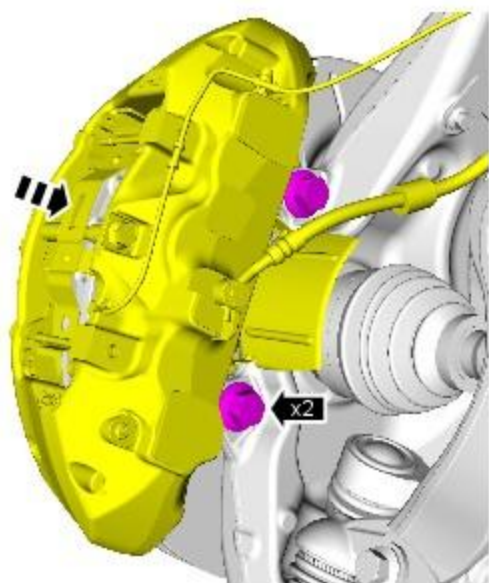

E142218

Service instruction

3.

NOTE:

Use the front brake caliper bolts retained during step 2 of Service Inspection 2.

Install the front brake caliper.

- Install but do not fully tighten the 2 bolts.

4.

CAUTION:

New front brake caliper bolts must be used during this step.

Renew the front wheel knuckle, (see TOPIx Workshop Manual section 204-01: Front Suspension - Removal and Installation - Wheel Knuckle).

5. If both front wheel knuckles **FAILED** Service Inspection 3, repeat steps 1 to 4 for the other side.

FRONT KNUCKLE BRACKET INSTALLATION PROCEDURE

The Front Bracket Installation Procedure **MUST** be completed on front wheel knuckles that **FAILED** Service Inspection 1, **FAILED** Service Inspection 2 and **PASSED** Service Inspection 3.

Service instruction

1. The area of the front knuckle shown highlighted in the illustrations must be clean and free from contamination.

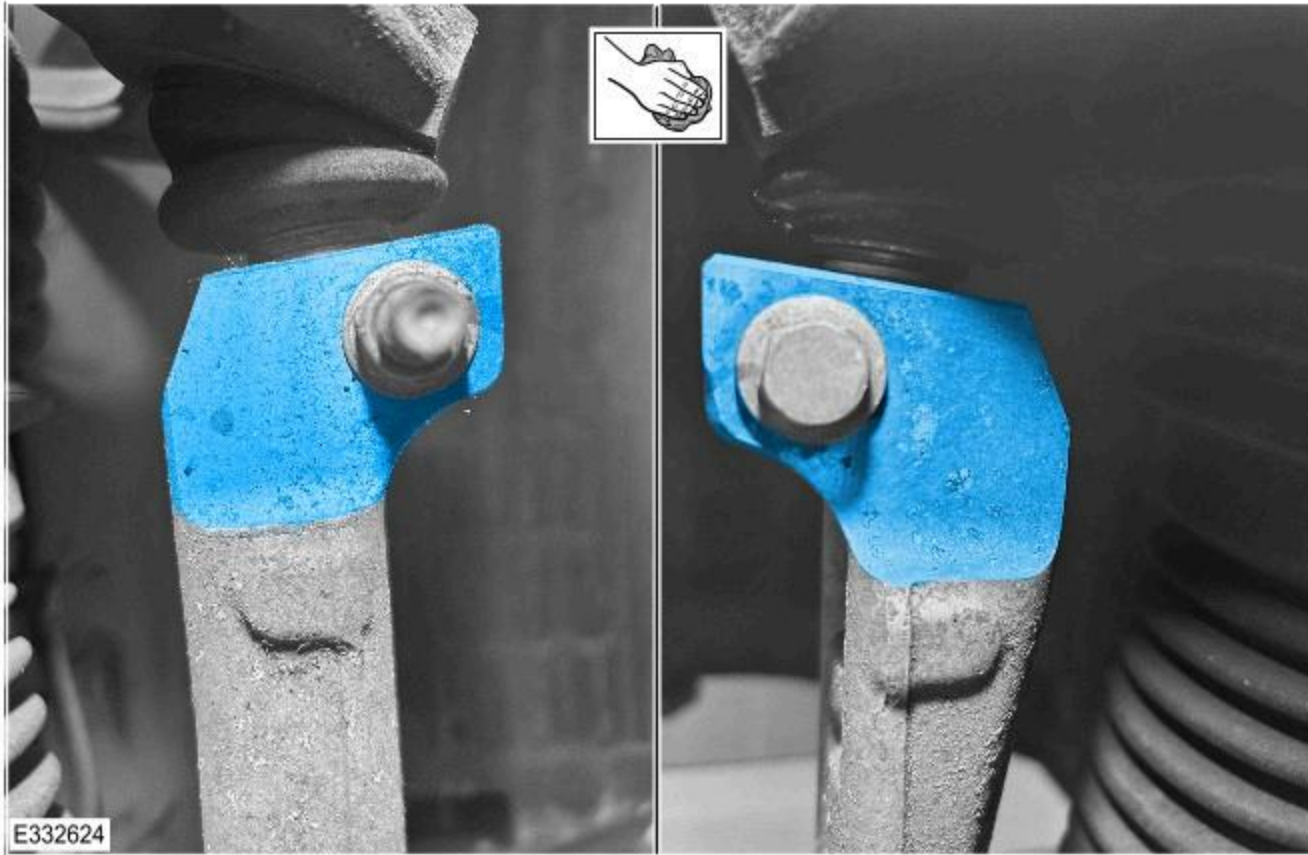



Service instruction

2. Install the 2 front knuckle bracket side hooks.

- Apply Loctite® 243 to the bolt.
- Install the bolt, finger tight only at this stage.

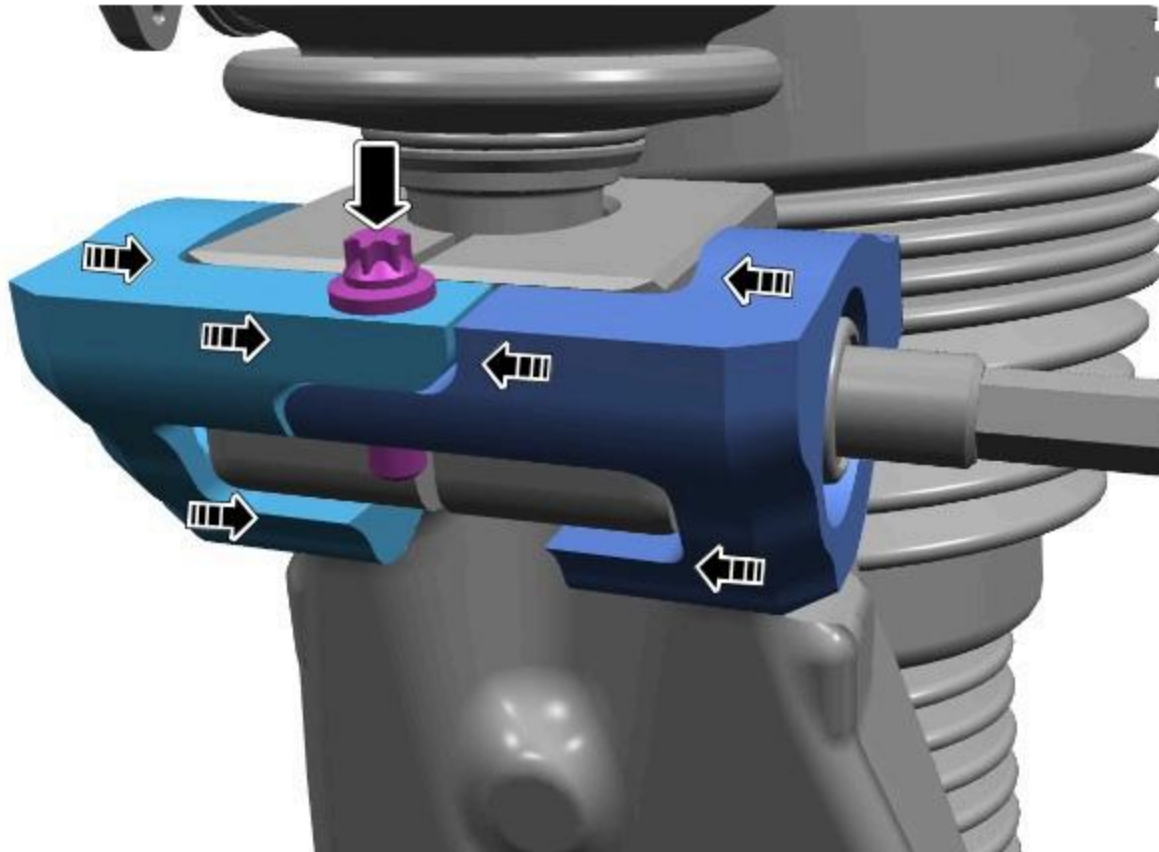

E373427

3.

CAUTION:

The front knuckle bracket rear plate must be installed with the part number facing outward from the front wheel knuckle.

Install the front knuckle bracket rear plate.

- Apply Loctite© 243 to the 2 bolts.
- Install the 2 bolts, finger tight only at this stage.

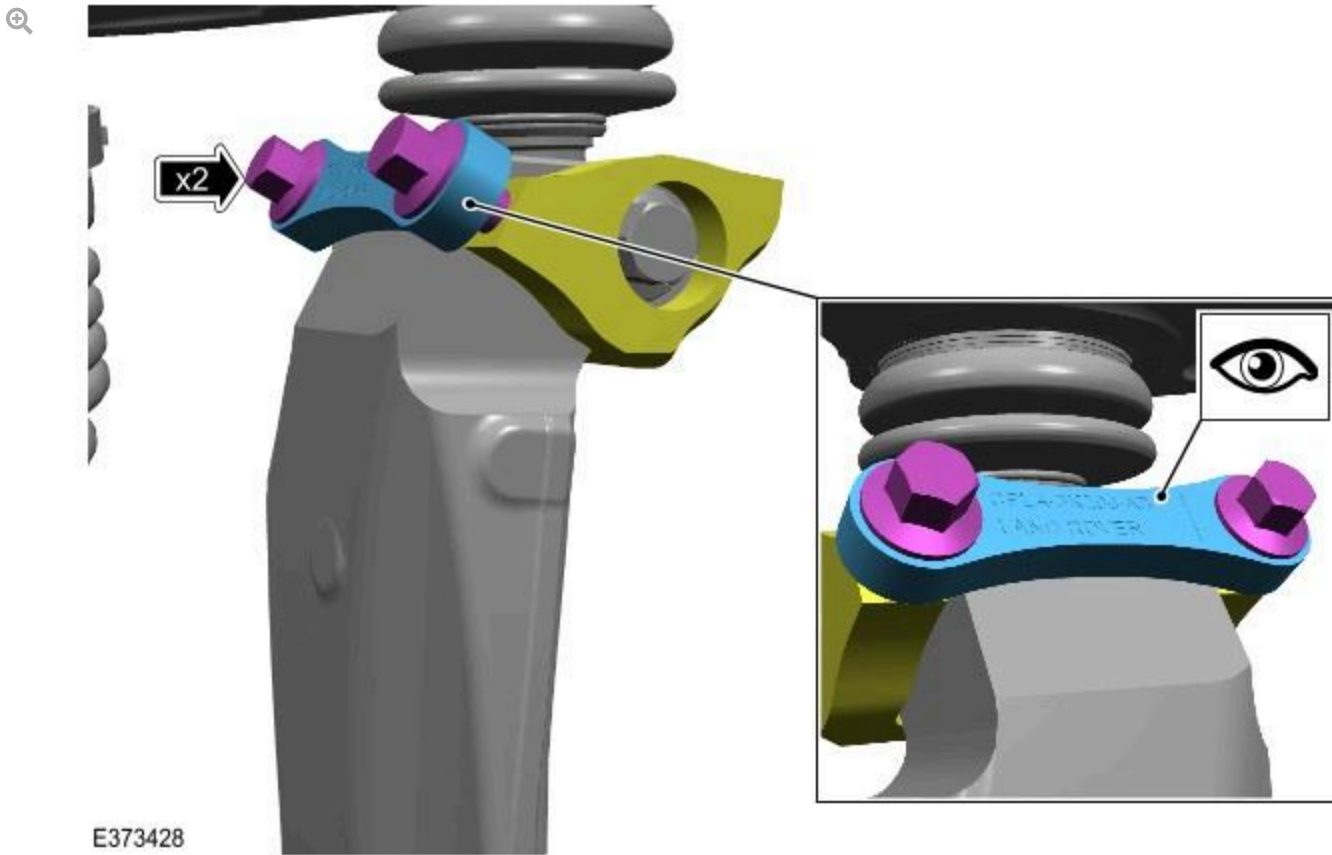

<p class="bold">Service instruction</p>

4. Align the front knuckle bracket to be central to the front knuckle.

- The front knuckle bracket must be centrally aligned to the front wheel knuckle as shown in the illustration with the **GREEN ✓**.
- The front knuckle bracket must not be aligned to the front wheel knuckle as shown in the illustrations with the **RED X**.

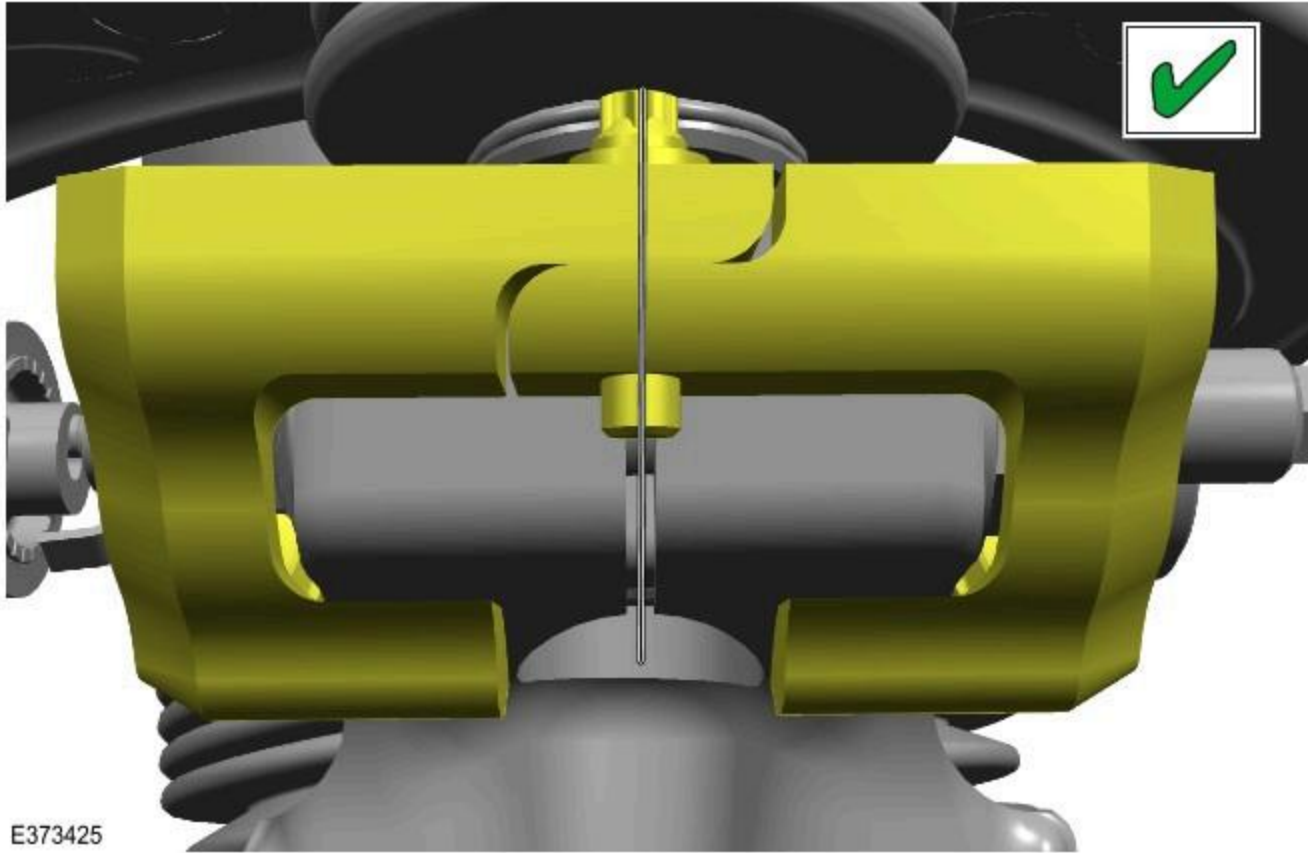

E373425

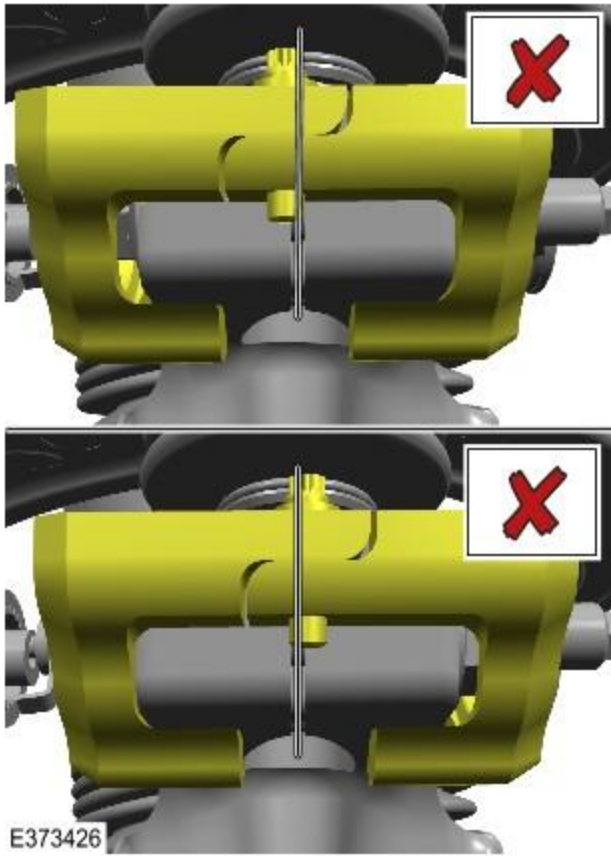

5.

CAUTIONS:

- There must be a gap between the front knuckle bracket rear plate and the 2 front knuckle bracket side hooks.
- The gap between the front knuckle bracket rear plate and the 2 front knuckle bracket side hooks must be maintained both sides of the front knuckle bracket rear plate.
- The front knuckle bracket must remain central to the front knuckle during tightening, as shown in the illustration.
- The M5 bolt torque must be checked after the 2 M8 bolts have been tightened.

Fully tighten the 3 front knuckle bracket bolts.

1. M5 Bolt: **6 Nm**
2. M8 Bolts:
 - Stage 1: **10 Nm**
 - Stage 2: **24 Nm**
3. Re-torque the M5 Bolt: **6 Nm**

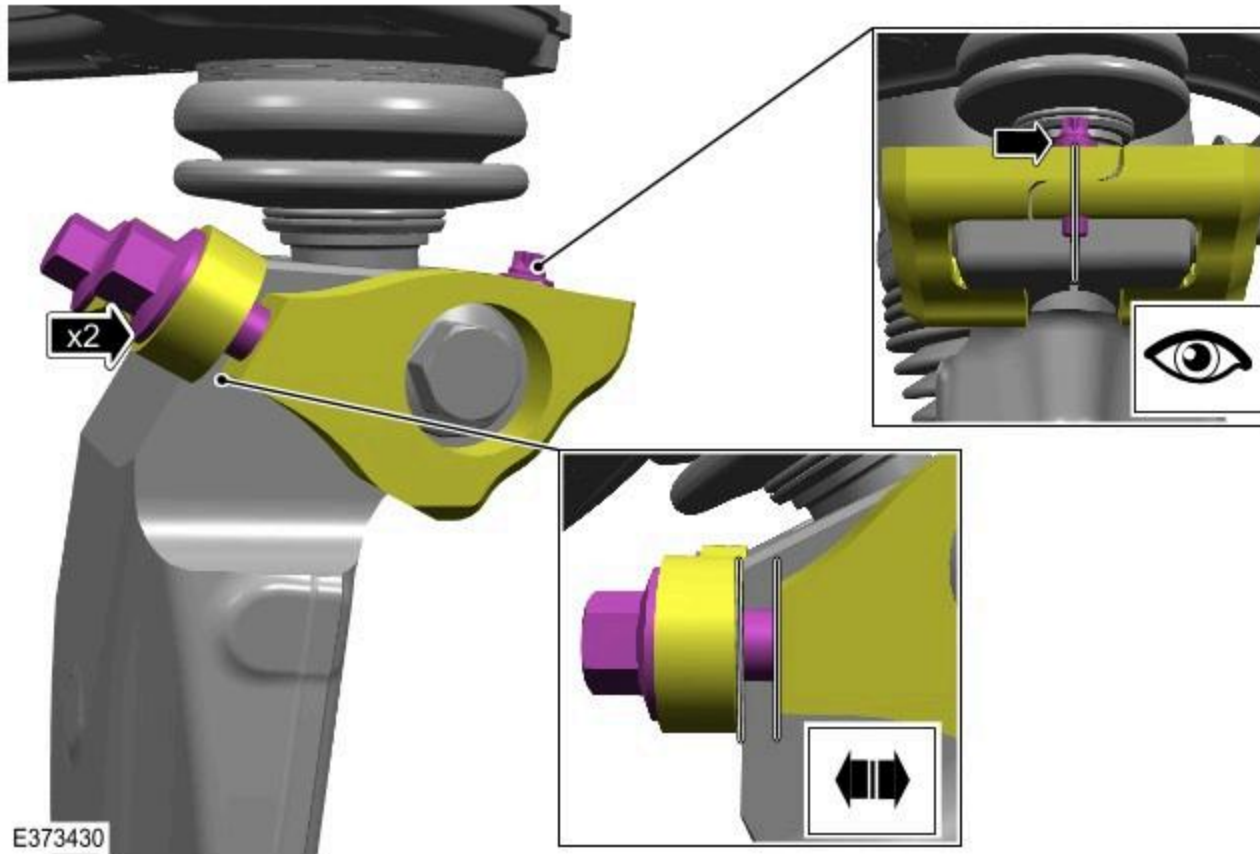

6. Install the front wheel and tire assembly (see TOPIx Workshop Manual section 204-04: Wheels and Tires - Removal and Installation - Wheel and Tire).

7. Repeat steps 1 to 6 for the other side if required.

SAMPLE CUSTOMER LETTER - FOR INFORMATION ONLY

Name
Address line 1
Address line 2
Address line 3
Post Code

Vehicle Identification Number (VIN):
Registration Number:
Program Number: N759

Date: month/year

SAFETY RELATED RECALL - Range Rover - Range Rover (L405) Front Suspension Knuckle Crack

Dear

JLR Limited would like to advise you that during ongoing quality assessment of our product it has been identified that a possible safety related problem may occur on certain Range Rover vehicles within a specific production range. Read the information below, this will explain the actions that we intend to take and what you are required to do.

Why are we contacting you?

A concern has been identified on certain 2014 model year to 2016 model year Range Rover vehicles where the front suspension upper knuckle joint could develop a crack. In extreme cases, a crack may lead to detachment from the upper suspension arm, which under heavy avoidance maneuver use conditions may compromise the vehicle's controllability and increase the risk of a crash.

What will your JLR retailer / authorized repairer do?

For each of the front suspension knuckles, the technician will first inspect the part to ascertain if it is an at-risk part supplied by SAI, or a previous level of part which is deemed not to pose a risk. If the latter, no action will be taken for that knuckle. If the part is an SAI-supplied at-risk part, the technician will inspect the suspension knuckle for the presence of any cracks. Where no crack is present and where available, a retaining bracket will be installed to the joint. Where cracks are found or a bracket is not available, the front suspension knuckle will be replaced.

How long will it take?

The work on your vehicle will be completed as quickly and efficiently as possible in order to minimize inconvenience to you. Your JLR retailer / authorized repairer will be able to advise how long your vehicle will be required for when a booking is made.

What we are asking you to do

Contact your preferred JLR retailer / authorized repairer without delay. To book your vehicle in for this action you must provide the JLR retailer / authorized repairer with the following which are detailed at the beginning of this letter:

- The VIN for your vehicle
- Vehicle registration number of your vehicle.
- The program code for the action.

If you do not have a JLR retailer / authorized repairer, access www.landrover.co.uk or www.landrover.com for contact details.

If you no longer own the vehicle could you complete the 'Change of Ownership' slip attached to this letter, returning the slip to JLR Limited immediately in the enclosed 'Freepost' envelope. This will enable us to make contact with the new owner.

If you have concerns

If you experience any concerns relating to this Recall, contact the Service Manager at the JLR retailer / authorized repairer for assistance or contact the JLR Limited Customer Experience Centre on 0345 303 2303 or (enter phone number).

This bulletin is being issued in accordance with the legislative or industry requirements concerning vehicle defects. The authorities will closely monitor the response rate of this bulletin.

Please treat this matter with the urgency it requires, JLR Limited apologize for any inconvenience this bulletin may cause and thank you, in advance, for your co-operation.

Yours sincerely

Head of Business

Technical Questions And Answers	
FOR USE ON ENQUIRY	
JLR Recall N759 only	
Range Rover (L405) Front Suspension Knuckle Crack	

A concern has been identified on certain Range Rover (L405) vehicles manufactured between 01 October 2014 and 31 March 2015 where the front suspension upper knuckle joint could develop a crack. In extreme cases this may lead to detachment of the upper suspension arm.

Question 1

Why is JLR recalling certain models?

Answer

JLR is conducting a voluntary recall on certain 2014 model year to 2016 Model Year Range Rover vehicles. Customers will be asked to take their vehicles to an authorized repairer to have the front suspension knuckles inspected and replaced or a retaining bracket installed if within the at-risk range.

Question 2

Can you tell me more about what is wrong with the vehicles?

Answer

A crack in the front suspension knuckle may propagate which may lead to a detachment of the upper suspension arm. Under an extreme avoidance maneuver use conditions this may compromise the vehicle's controllability and increase the risk of a crash.

Question 3

How would the customer become aware of potentially having this concern?

Answer

Where a crack starts, knocking noises from the front of the vehicle may be heard. Where the detachment of the suspension arm occurs, it may collide with air suspension spring and other inner fender parts. Steering feel will be impacted as the camber and toe angles of the affected wheel are changed.

Question 4

Has JLR received many complaints?

Answer

JLR is aware of a number of field reports attributed to this concern.

Question 5

Does this concern affect vehicle safety?

Answer

JLR has determined that in extreme use cases, where a vehicle's controllability is compromised, there is an effect on safety.

Question 6

Are there any precautions that can be taken to minimize the risk until the corrective measures are implemented?

Answer

Affected customers will be contacted directly by JLR and are advised to book their vehicles in for repair as soon as possible.

If unusual noises be heard such as knocking from the front of the vehicle, customers are advised to contact a JLR retailer / authorized repairer to have this investigated.

Question 7

Have there been any accidents or injuries or fires?

Answer

There have been a small number of reports of accidents, but no reports of injuries or fires as a result of this concern.

Question 8

Is the defect leading you to any concerns regarding the reliability of the vehicle?

Answer

JLR has no concerns with the overall reliability of the vehicle. JLR carefully monitors field data to make sure that any matters relating to safety and compliance are rigorously investigated.

Question 9

How was the concern discovered?

Answer

The defect was discovered through a combination of Government Agency defect investigations, warranty claims and field reports.

Question 10

How long has JLR known about this concern?

Answer

JLR continuously monitors field data and reports of incidents affecting its vehicles. The recall decisions have been the result of a careful review of this data and engagement with several government authorities.

Question 11

What has JLR done in production?

Answer

These vehicles are no longer in production.

Question 12

What will JLR retailer / authorized repairers do to the vehicles?

Answer

Owners will be notified and instructed to take their vehicle to an approved JLR retailer / authorized repairer.

For each of the front suspension knuckles, the technician will first inspect the part to ascertain if it is an at-risk part supplied by SAI, or a previous level of part which is deemed not to pose a risk. If the latter, no action will be taken for that knuckle. If the part is an SAI-supplied at-risk part, the technician will inspect the suspension knuckle for the presence of any cracks. Where no crack is present and where available, a retaining bracket will be installed to the joint. Where cracks are found or a bracket is not available, the front suspension knuckle will be replaced.

There will be no charge to the owners for this repair.

Question 13

Which vehicles are affected by this recall?

Answer

2014 model year to 2016 model year Range Rover vehicles as below may be affected:

SALGA2EE2EA194746 to SALGA2AF4GA222581*

* Specific vehicles within the [Vehicle Identification Number \(VIN\)](#) range.

Question 14

Are other JLR models affected by these actions?

Answer

Certain other Range Rover vehicles, and Range Rover Sport vehicles, may be affected. Affected customers will be notified directly about these recalls, which are variously administered under JLR campaign references D019, D025, D027 and D041.

Question 15

Are parts available to rework vehicles?

Answer

The recalls will be launched when parts are available in sufficient quantity to fulfil the repair requirements.

Question 16

How much will the recall cost JLR?

Answer

Cost was not a factor in deciding to recall these vehicles.

Question 17

How do I know if my vehicle is affected?

Answer

All owners of potentially affected vehicles will shortly be contacted and invited to make an appointment with a JLR retailer / authorized repairer for the work to be completed.

In some countries, recall information is available online through the brand's web site.

For further information, the recall search functionality is publicly available on the TOPIx website.

Question 18

How long does it take for the vehicle to be inspected and repaired?

Answer

The work will be completed out as quickly and efficiently as possible in order to minimize inconvenience to customers and is expected to take no longer than two hours to complete. Naturally, due to JLR retailer / authorized repairer schedules, vehicles may be required for longer.

Note:

Any Press enquiries must be referred to the JLR Public Affairs office.