



**PREVOST**

# SAFETY RECALL

**SR25-23A**

DATE :	September 2025	SECTION :	18 BODY
SUBJECT:	<b>INSPECTION AMAYA SEATS</b>		

Revision: A

H3-45 vehicle population change

10-10-2025

## APPLICATION

<b>NOTICE TO SERVICE CENTERS</b>	
<i>Verify vehicle eligibility by checking warranty bulletin status with <b>SAP</b> or via <b>ONLINE WARRANTY SYSTEM</b> available on Service / Warranty tab of PrevoSt website.</i>	
<b>Model</b>	<b>VIN</b>
H3-45 coaches Model Year: 2025-2026	
X3-45 coaches Model Year: 2025	
<b>This Safety Recall does not necessarily apply to all the above-mentioned vehicles. Some vehicles may also have been modified before delivery. The owners of the vehicles affected by this recall will be advised by a letter indicating the Vehicle Identification Number (VIN) of each vehicle concerned.</b>	





## DESCRIPTION

On vehicles affected by this recall, you must inspect all the nuts on the seat belts, belt buckles, backrests and seat cushions, and retighten them if necessary.

## MATERIAL

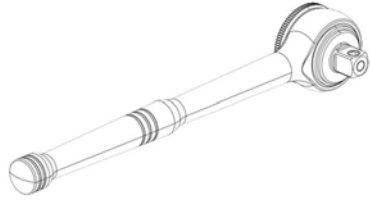
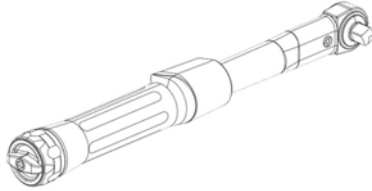
No material is needed for this bulletin.

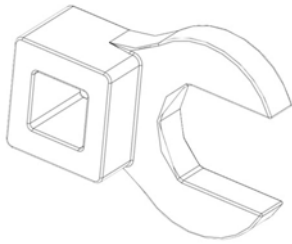
**REQUIRED TOOLS**

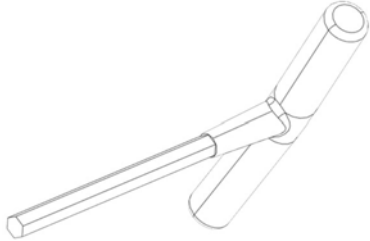
<p>RATCHET / 3/8" DRIVE</p> 	<p>TORQUE WRENCH / 3/8" DRIVE</p> 	<p>SOCKETS 7/16" - 5/8" - 17MM</p> 
<p>CROW FOOT 5/8" - 17MM</p> 	<p>WRENCH 5/8"</p> 	<p>ALLEN WRENCH 8 MM</p> 

## SAFETY PRECAUTIONS

- Eye protection should always be worn when working in a shop.
- Rules for Personal Protection Equipment should always be respected. Wear your PPE including but not limited to the following:



# Safety First!



## PROCEDURE



### DANGER

Park vehicle safely, apply parking brake, stop the engine. Prior to working on the vehicle, set the ignition switch to the OFF position and trip the main circuit breakers equipped with a trip button. On Commuter type vehicles, set the battery master switch (master cut-out) to the OFF position.

Lockout & Tag out (LOTO) must be performed during set-up, maintenance or repair activities. Refer to your local procedure for detailed information regarding the control of hazardous energy.

## INSPECTION OF STANDARD SEAT

1. Remove the nuts (2x) and remove the aisle side seat cushion.

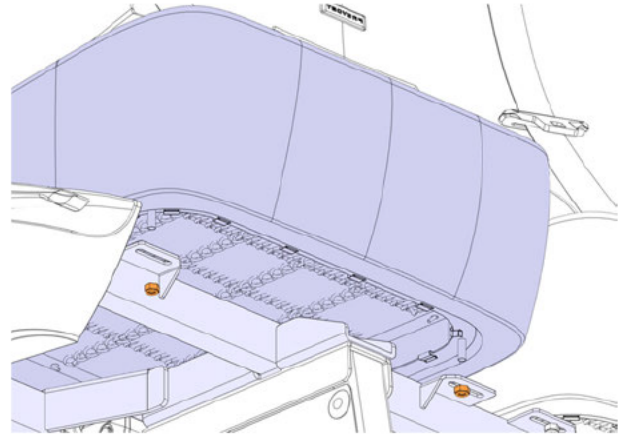

2. Verify that belt nuts (2x) are firmly seated and that at least 2 threads are protruding.

**Note:** for the window-side belt, you must push the plastic cover to inspect.

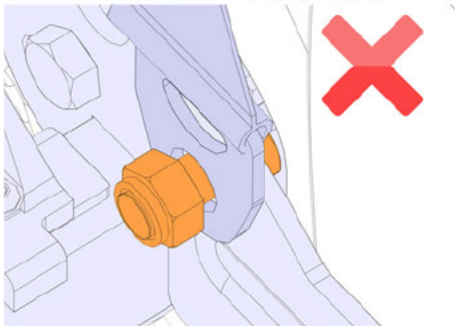
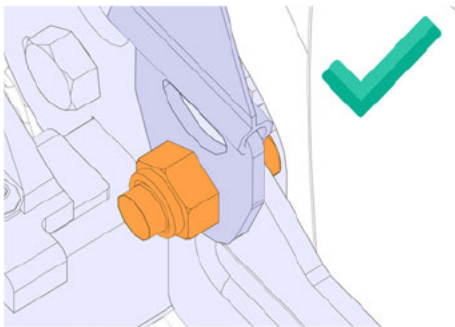

- If OK, go to the next step.
- If not, go to the **retighten nuts** section.

CENTER OF SEAT

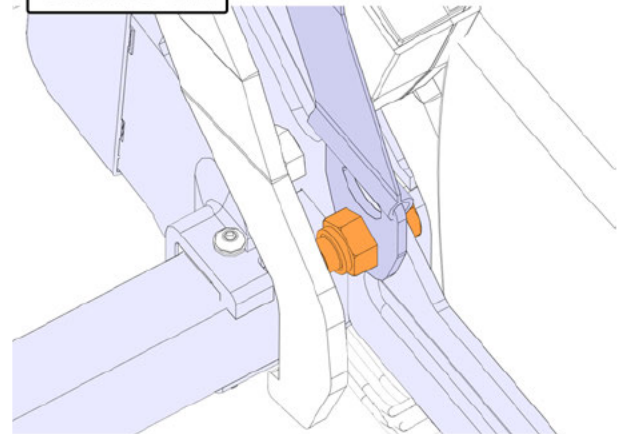

WINDOW SIDE



3. Verify that the buckle nuts (2x) are firmly seated and that at least 2 threads are protruding.

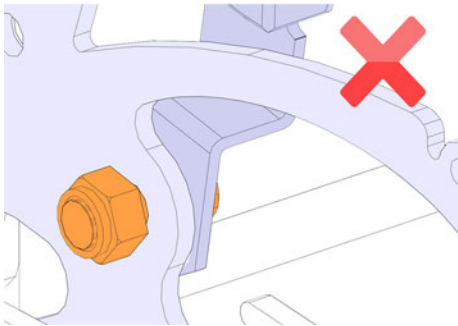
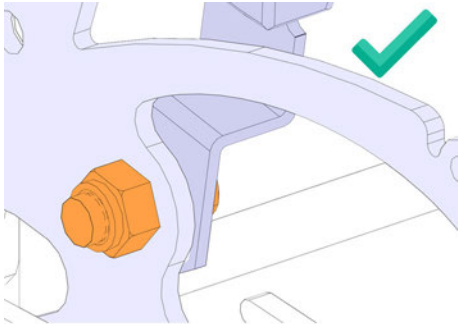

- If OK, go to the next step.
- If not, go to the **retighten nuts** section.

CENTER OF SEAT

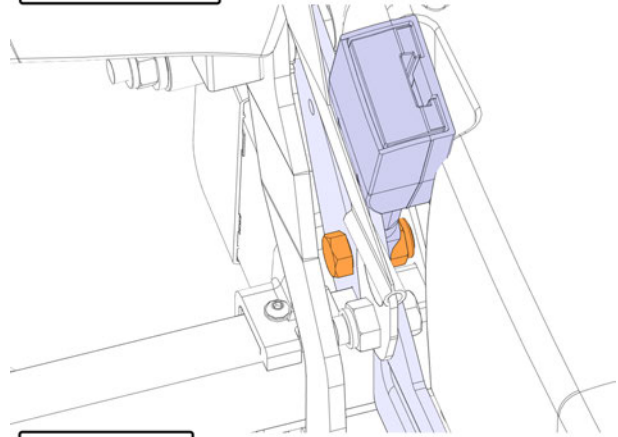

AISLE SIDE

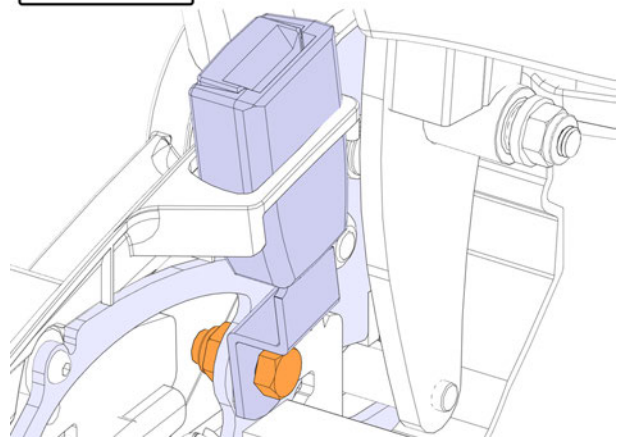

4. Verify that backrest nuts (3x) are firmly seated and that at least 2 threads are protruding.

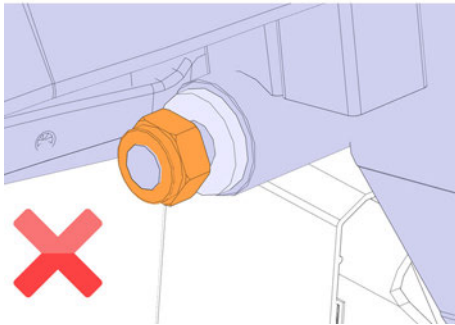
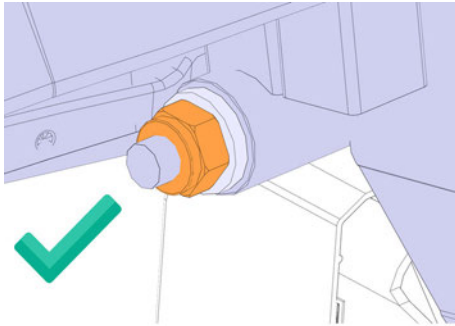

- If OK, go to the next step.
- If not, go to the **retighten nuts** section.

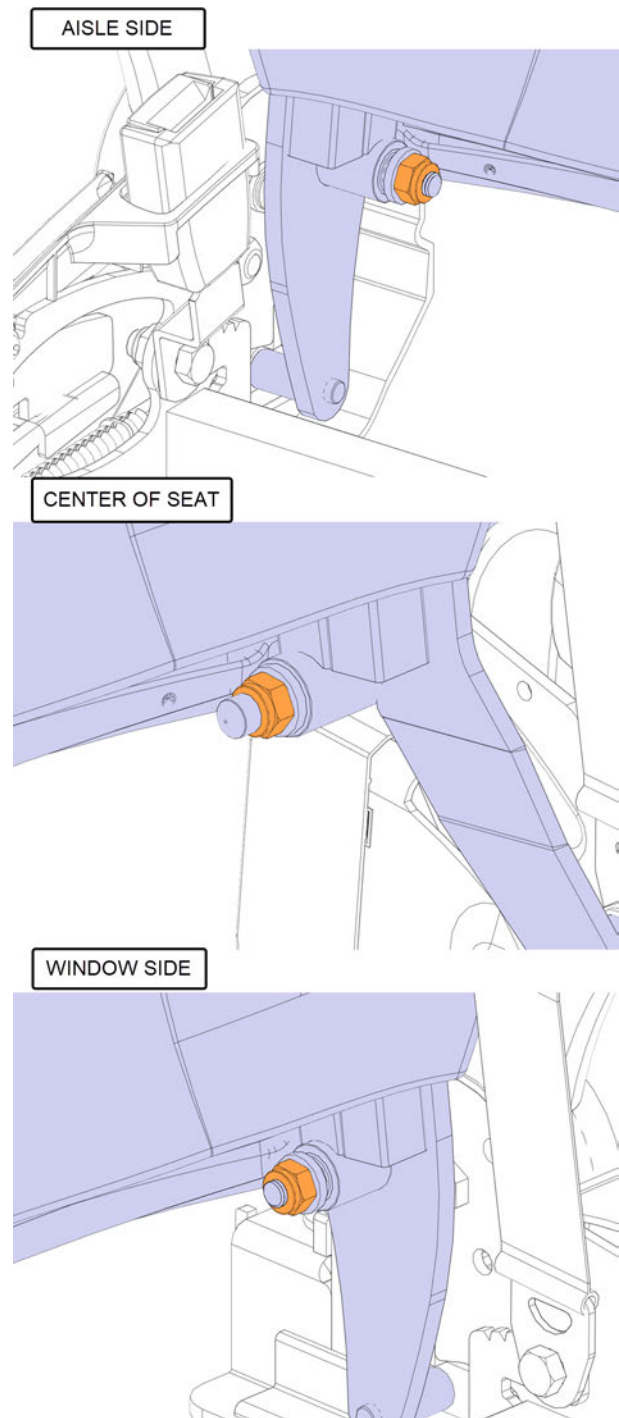

5. Verify that the window's side seat cushion nuts (2x) are firmly seated and that at least 2 threads are protruding.

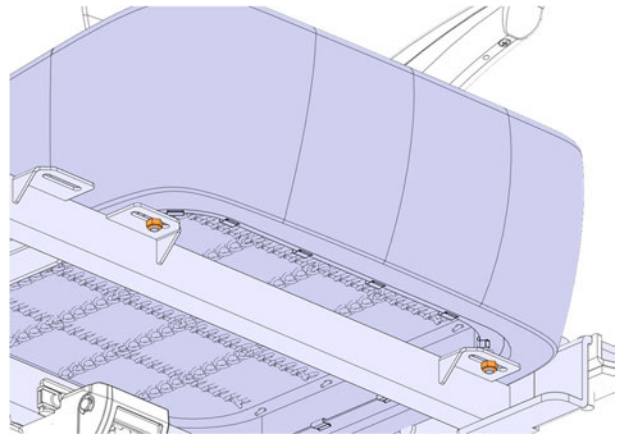
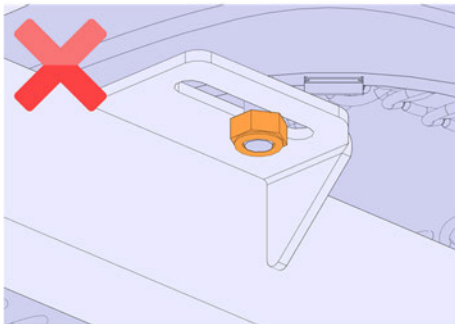
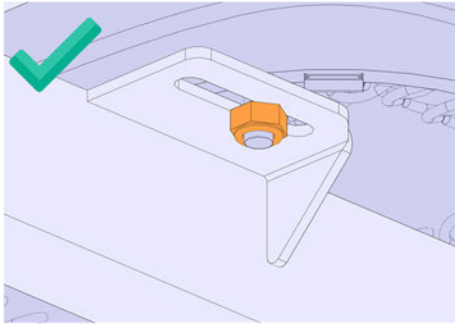

- If OK, go to the next step.
- If not, go to the **retighten nuts** section.

6. Reinstall the cushion on the aisle side, ensuring that the nuts (2x) are firmly in place and that at least two threads protrude.

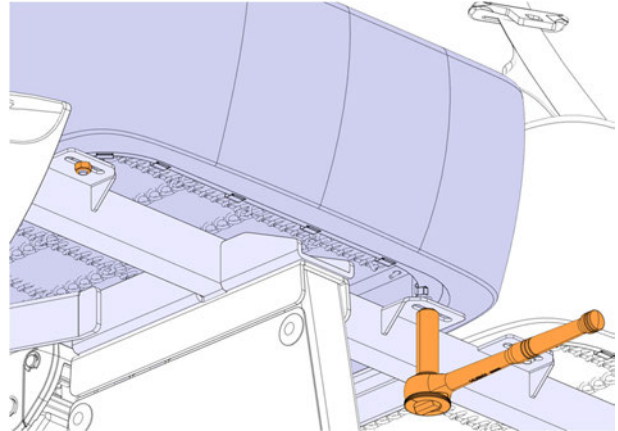

## INSPECTION OF FLIP-UP SEAT

1. Remove the two screws from the side cover on the window side.

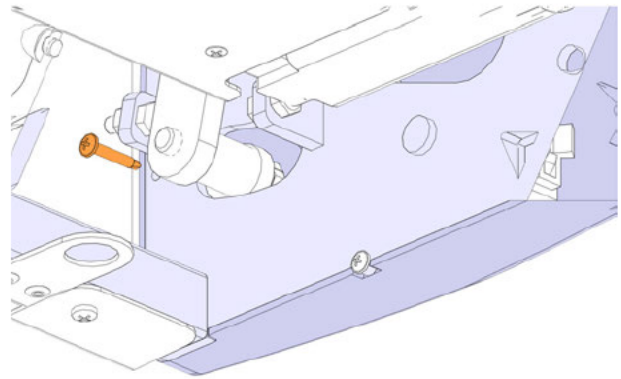
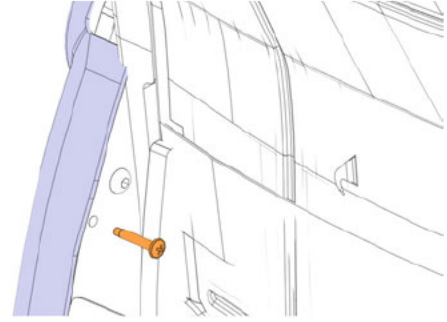

2. Pull the top of the cover to inspect
3. Verify that the belt nut is firmly seated and that at least 2 threads are protruding.

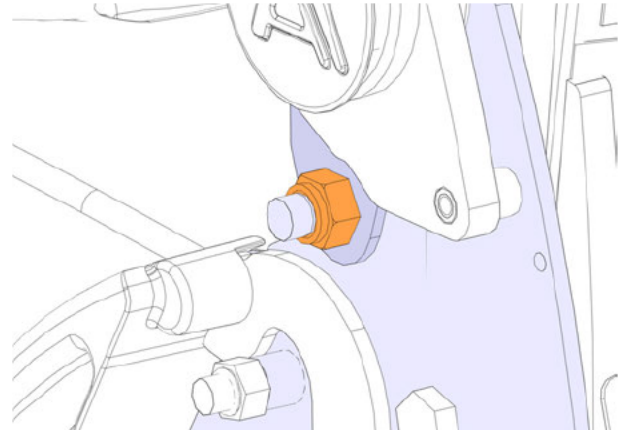
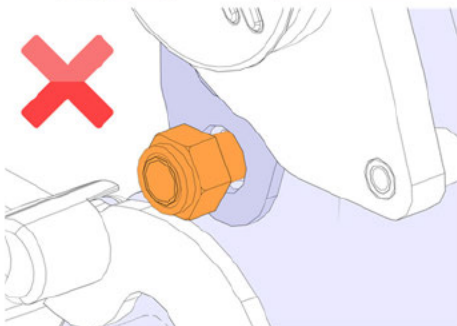
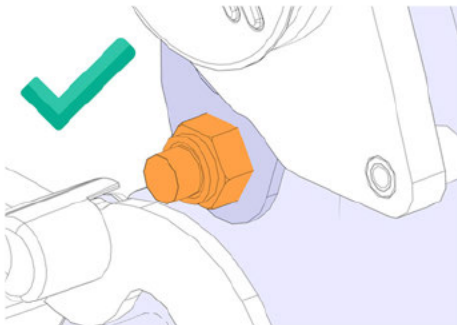

- If OK, go to the next step.
- If not, go to the **retighten nuts** section.

4. Reinstall the two screws from the side cover on the window side

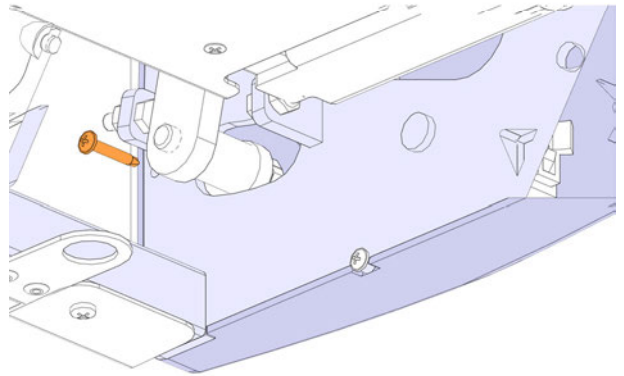
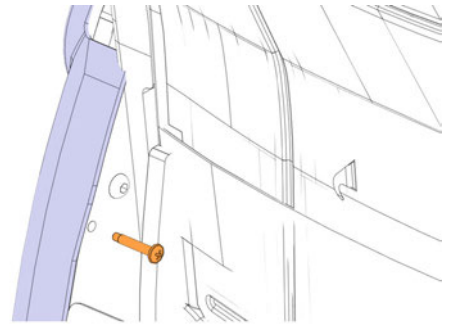

5. Remove the two screws from the side cover on the aisle side.

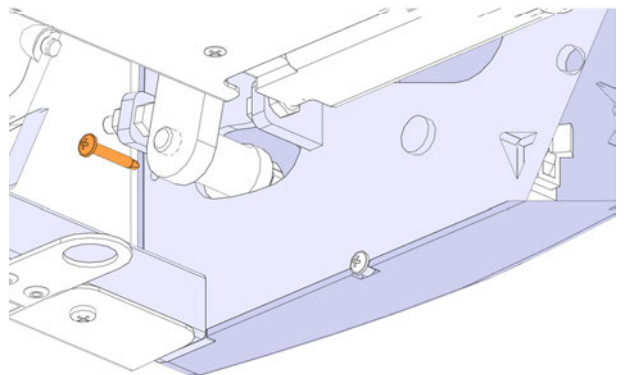
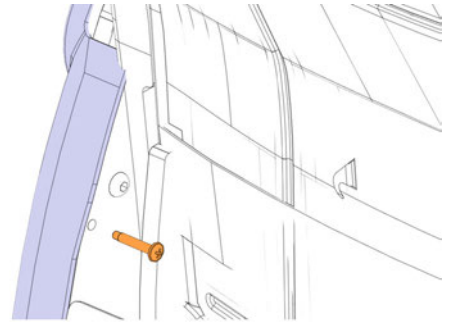

6. Pull the top of the cover to inspect
7. Verify that the buckle nut is firmly seated and that at least 2 threads are protruding.

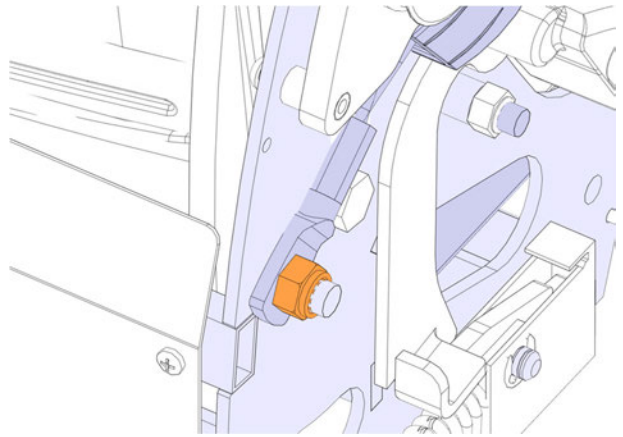
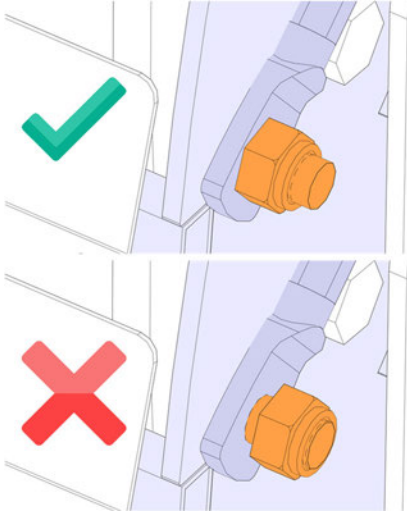

- If OK, go to the next step.
- If not, go to the **retighten nuts** section.

8. Reinstall the two screws of the aisle lateral cover.

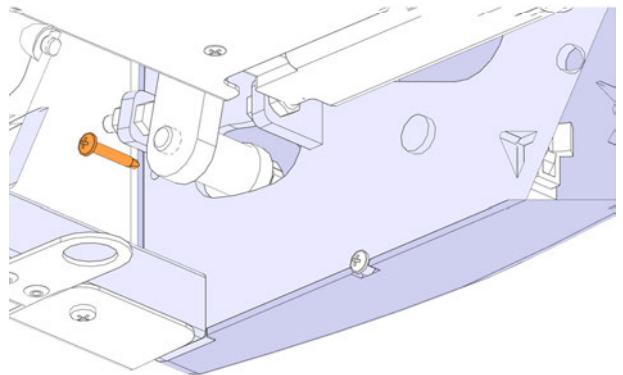
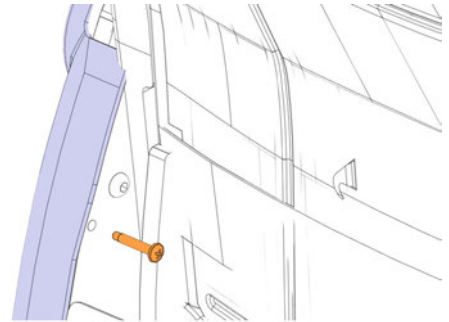

9. Pull the handle under the seat and flip the seat cushion.

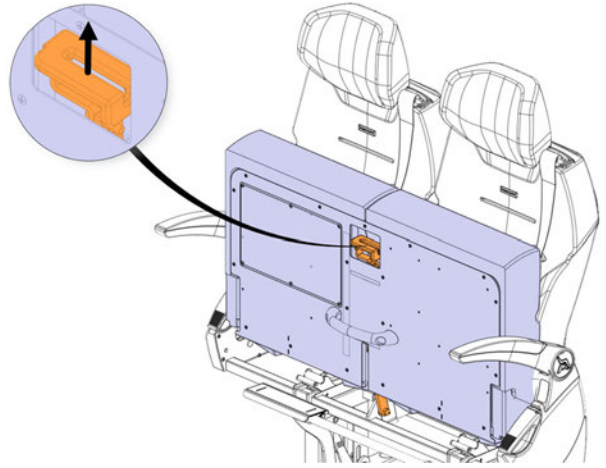

10. Verify that the buckle and belt nut is firmly seated and that at least 2 threads are protruding.

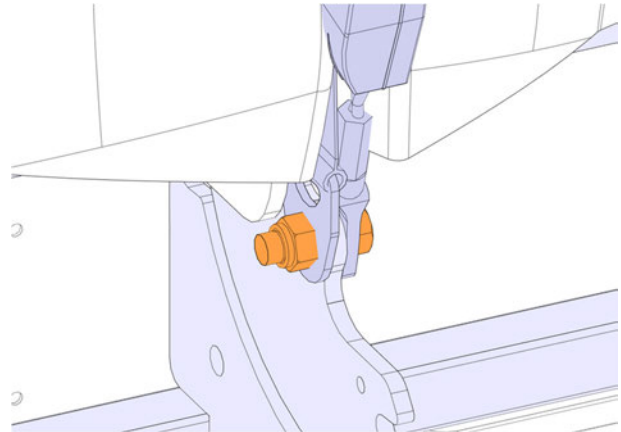
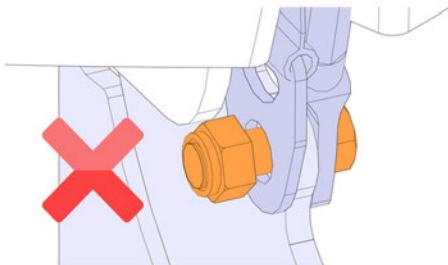
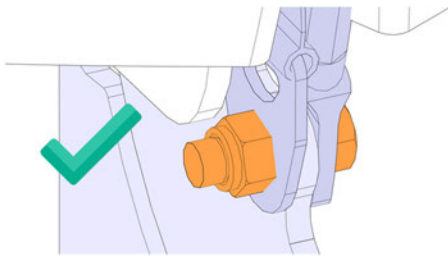

- If OK, go to the next step.
- If not, go to the **retighten nuts** section.

11. Verify that backrest nuts (3x) are firmly seated and that at least 2 threads are protruding.

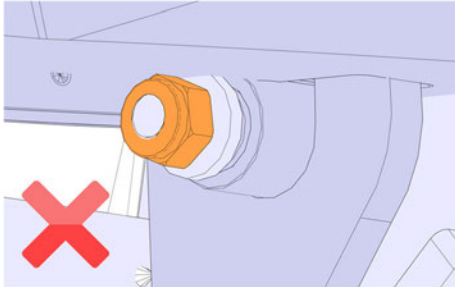
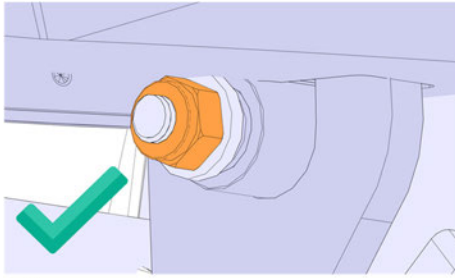

- If OK, go to the next step.
- If not, go to the **retighten nuts** section.

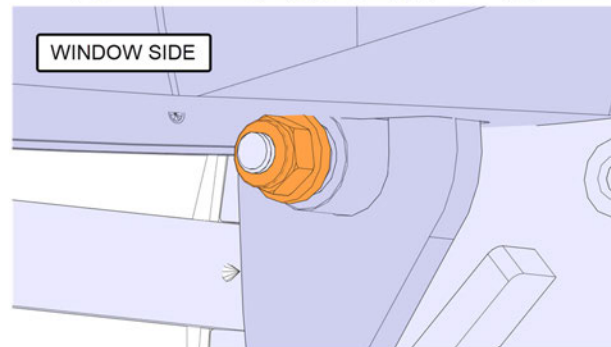
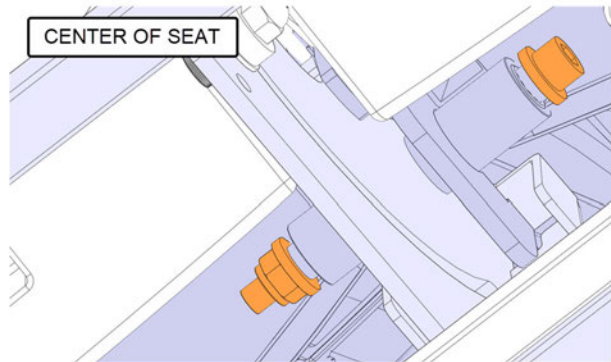
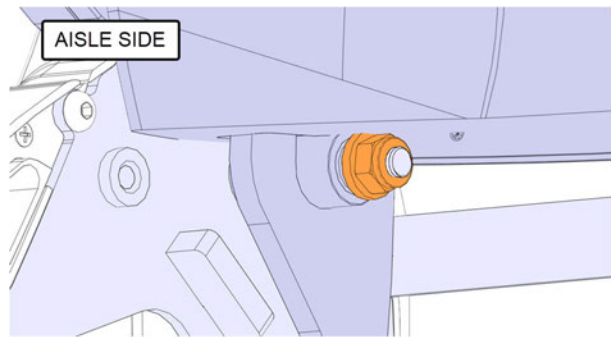

## INSPECTION OF REAR CROSS SEAT - X3-45 ONLY

1. Remove the nuts (6x) and remove the seat cushions (3x).

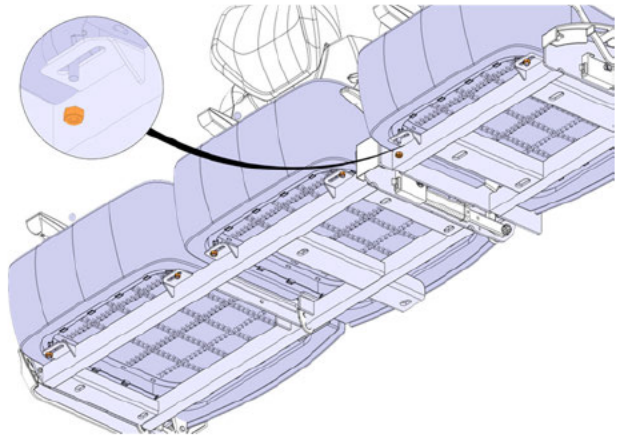

2. Verify that belt nuts (3x) are firmly seated and that at least 2 threads are protruding.

**Note:** for the window-side belt, you must push the plastic cover to inspect.

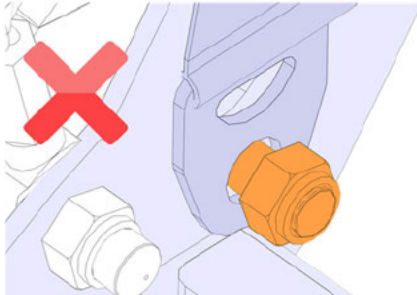
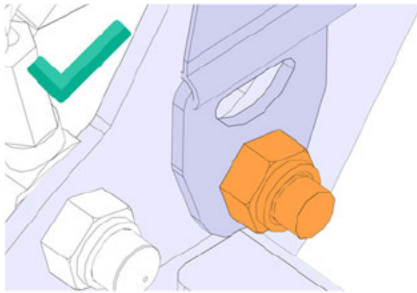

- If OK, go to the next step.
- If not, go to the **retighten nuts** section.

WINDOW SIDE

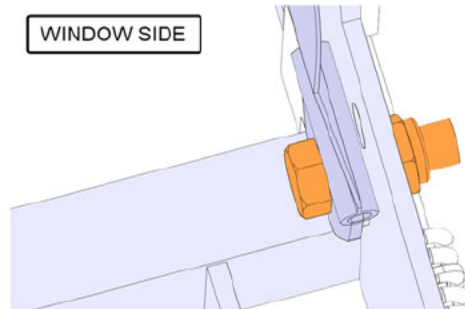

MIDDLE SEAT



AISLE SIDE

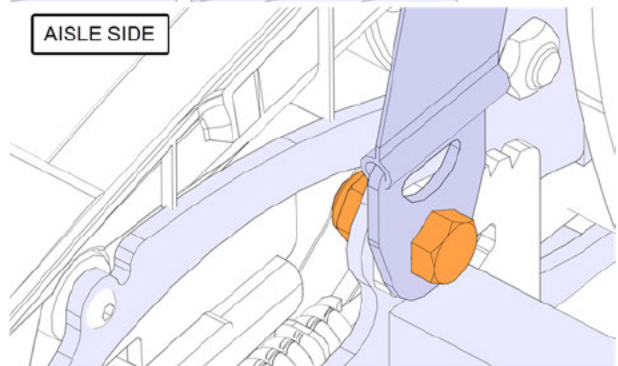

3. Verify that the buckle nuts (3x) are firmly seated and that at least 2 threads are protruding.

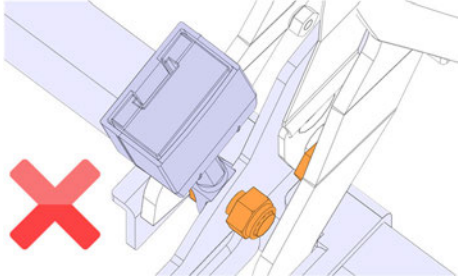
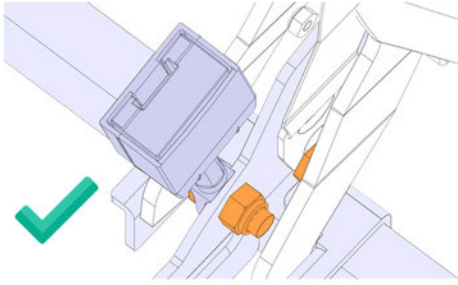

- If OK, go to the next step.
- If not, go to the **retighten nuts** section.

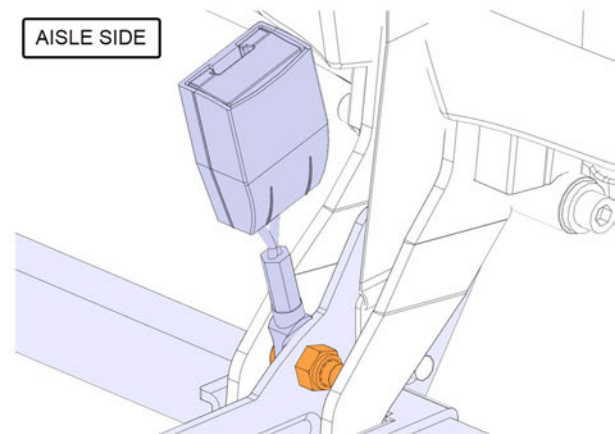
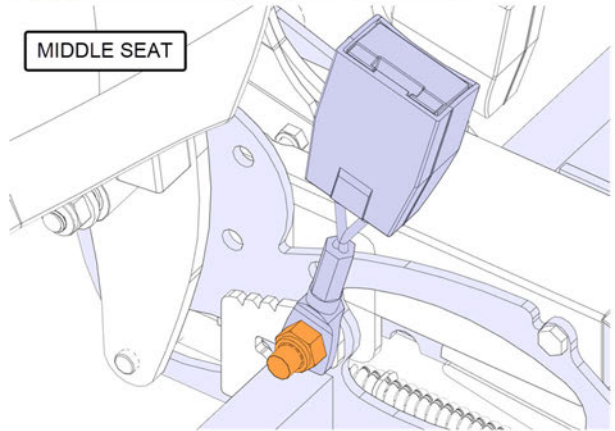
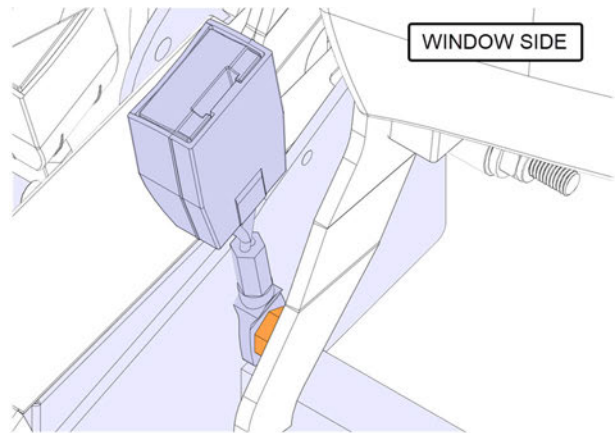

4. Verify that backrest nuts (5x) are firmly seated and that at least 2 threads are protruding.

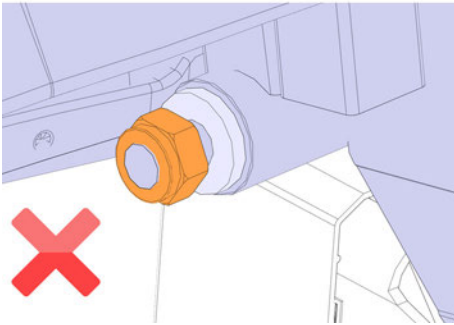
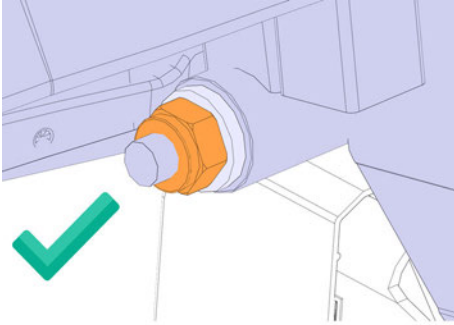

- If OK, go to the next step.
- If not, go to the **retighten nuts** section.

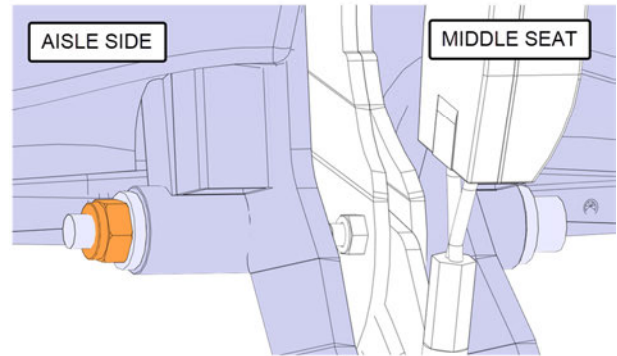
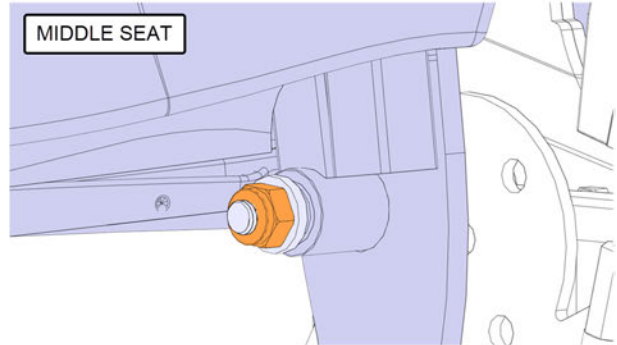
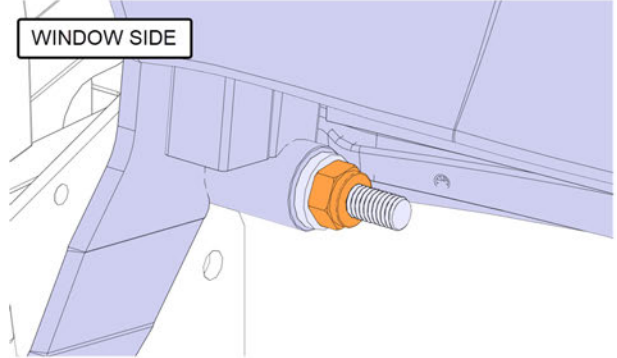
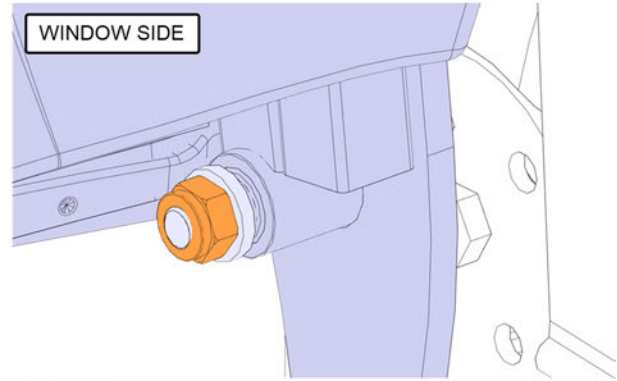

5. Reinstall the cushions (3x) with the nuts (6x), ensuring that the nuts are firmly in place and that at least two threads protrude.

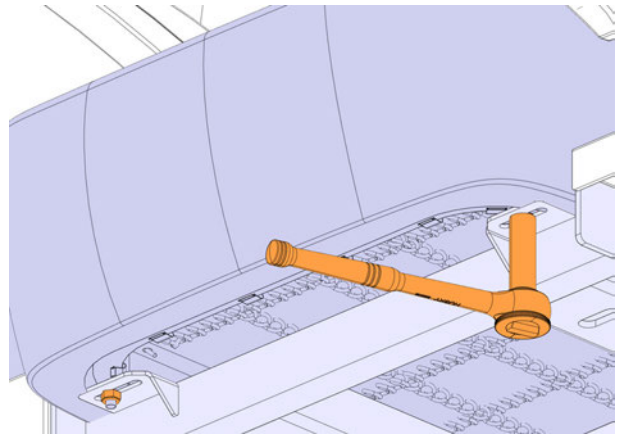

**RETIGHTEN NUTS STANDARD SEAT**

1. Remove the nuts (2x) and remove the aisle side seat cushion.

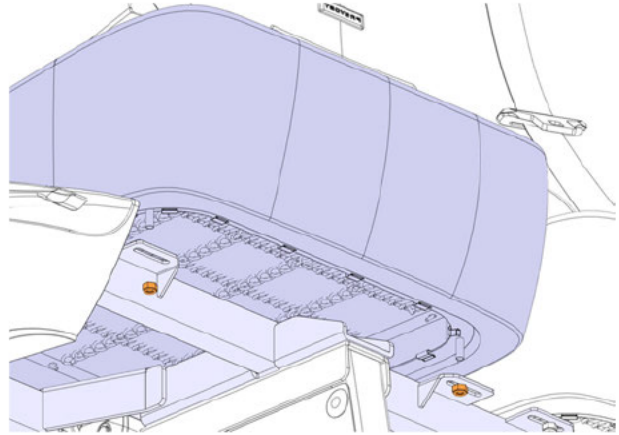

2. Retighten the nut (1x) of the aisle-side buckle and apply a torque of **32 lb-ft ± 3 lb-ft**.

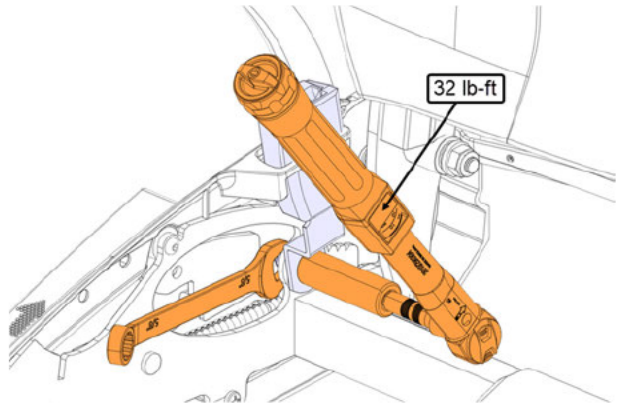

3. Retighten the nut (1x) of the center buckle and apply a torque of **32 lb-ft ± 3 lb-ft**.

**Note:** To access the nut, you must tilt the window's side backrest.

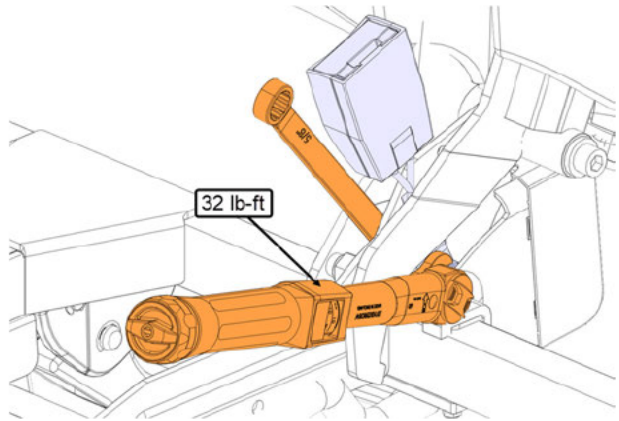

4. Retighten the nut (1x) of the center belt and apply a torque of **32 lb-ft ± 3 lb-ft**.

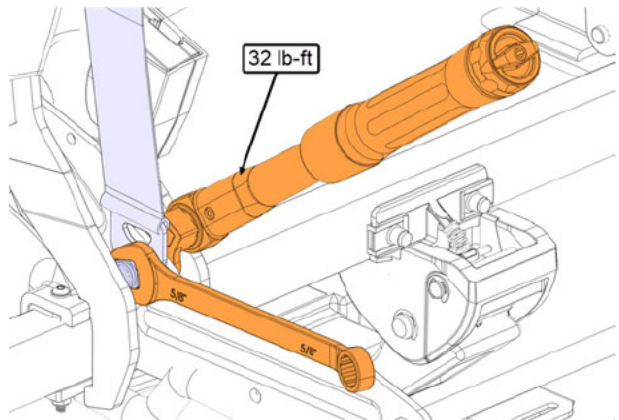

5. Retighten the nut (1x) of the window side belt and apply a torque of **32 lb-ft  $\pm$  3 lb-ft**.

**Note: To access the nut, you must pull the plastic finish.**

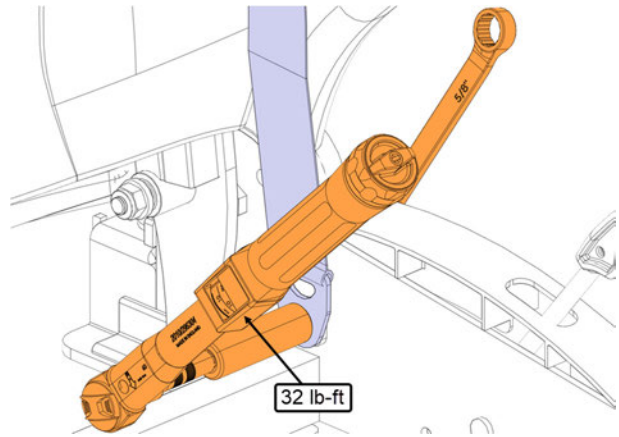

6. Retighten the aisle-side backrest nut (1x) so that it is firmly in place and at least two threads protrude.

**Note: Do not overtighten and check that the seat backrest tilts easily.**

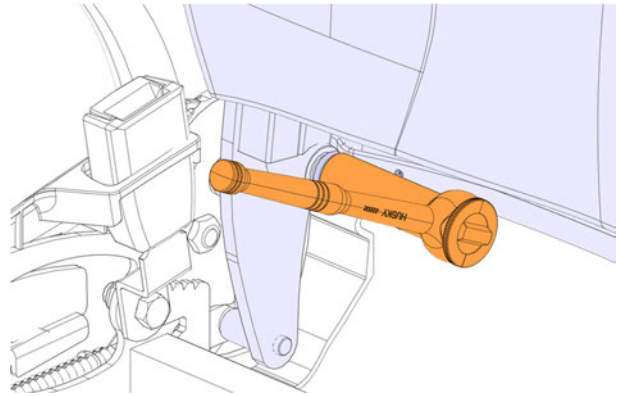

7. Retighten the backrests nut (1x) so that it is firmly in place and at least two threads protrude.

**Note: Do not overtighten and check that the seat backrest tilts easily.**

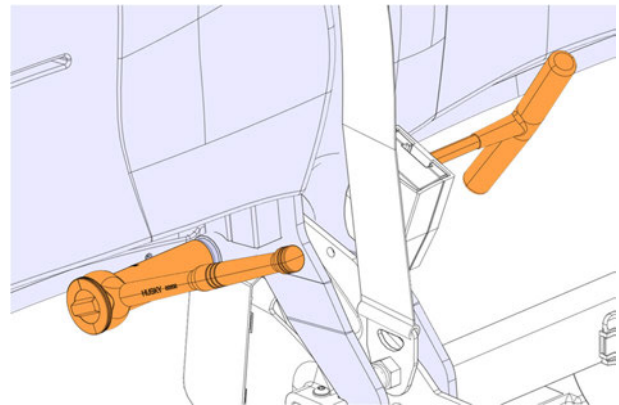

8. Retighten the window side backrest nut (1x) so that it is firmly in place and at least two threads protrude.

**Note: Do not overtighten and check that the seat backrest tilts easily.**

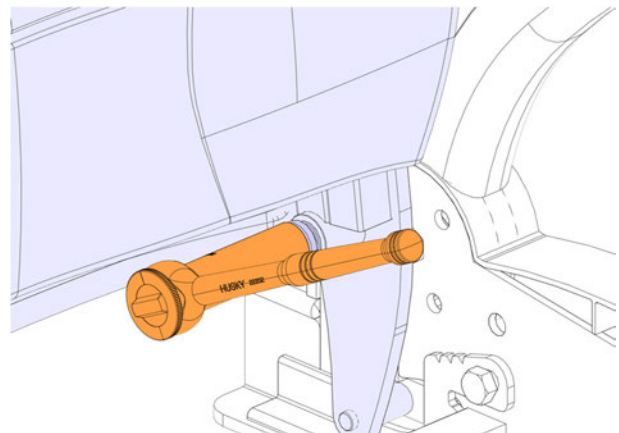

9. Tighten the nuts (2x) on the window side seat cushion so that they are firmly in place and at least two threads protrude.

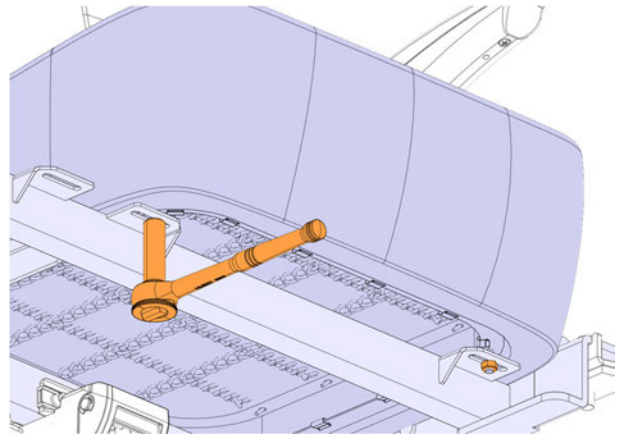

10. Reinstall the cushion on the aisle side, ensuring that the nuts (2x) are firmly in place and that at least two threads protrude.

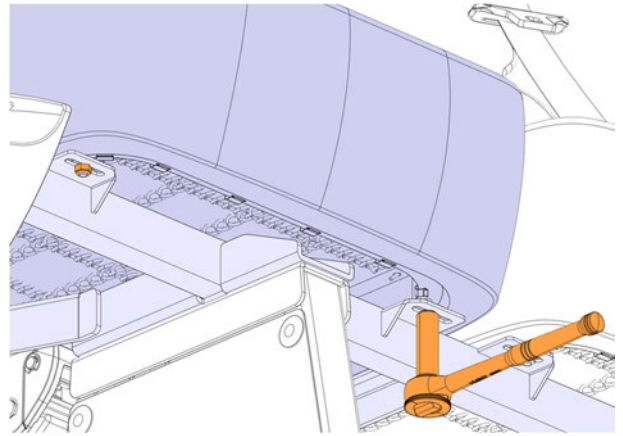

**RETIGHTEN NUTS FLIP-UP SEAT**

1. Remove the screws (6x) of the window side lateral cover.

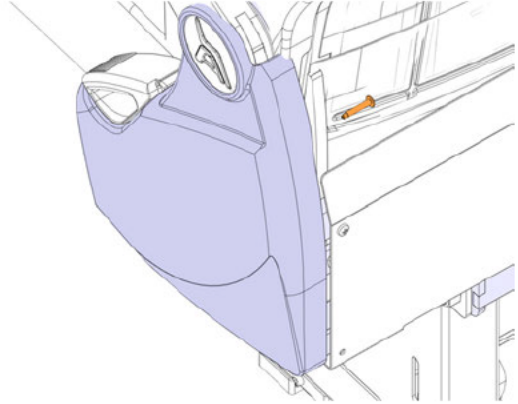

2. Retighten the nut (1x) on the window-side belt and apply a torque of **32 lb-ft  $\pm$  3 lb-ft**.

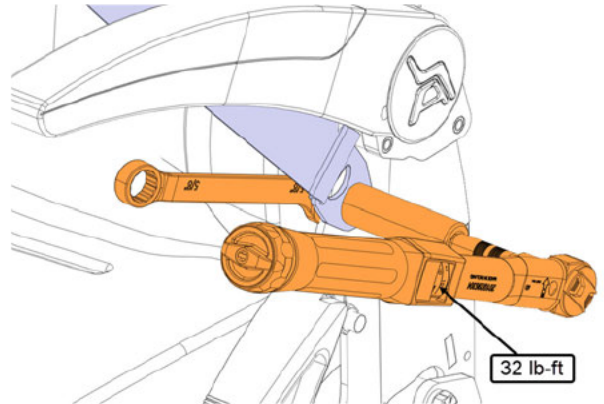

3. Reinstall the window side lateral cover with the screws (6x).

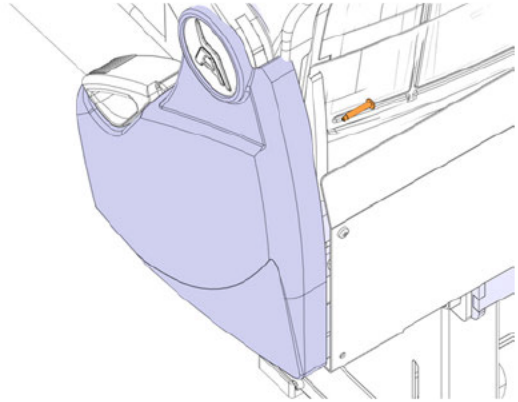

4. Retighten the nut (1x) on the center belt and buckle and apply a torque of **32 lb-ft  $\pm$  3 lb-ft**.

**Note:** To access the nut, tilt the backrests and fold up the cushion.

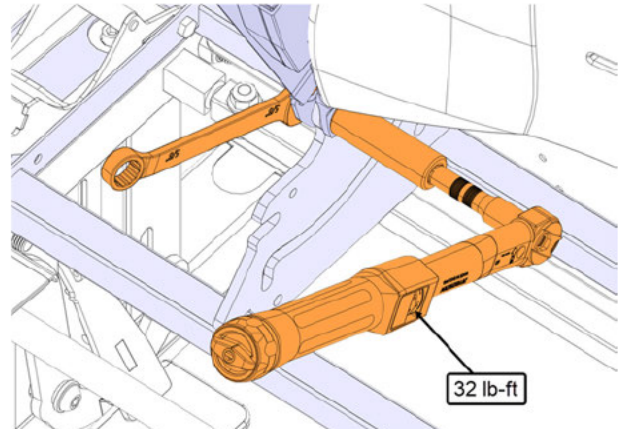

5. Remove the screws (6x) and remove the aisle side lateral cover.

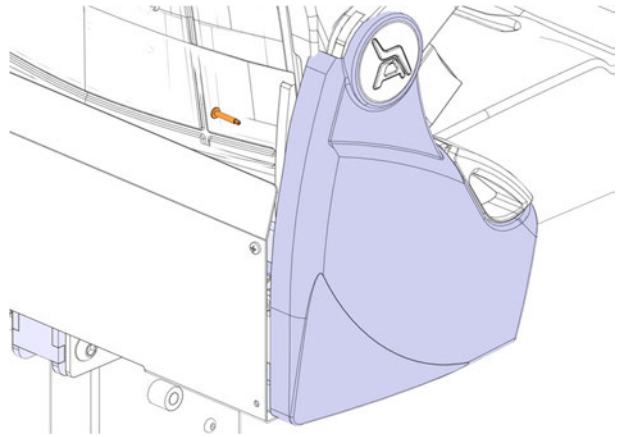

6. Retighten the nut (1x) on the aisle side buckle and apply a torque of **32 lb-ft ± 3 lb-ft**.

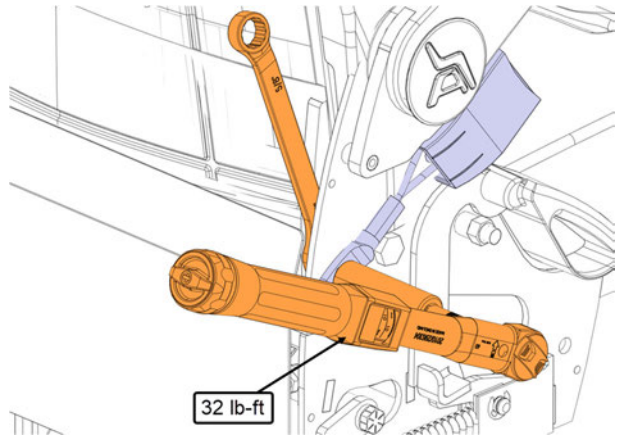

7. Reinstall the aisle side lateral cover with the screws (6x).

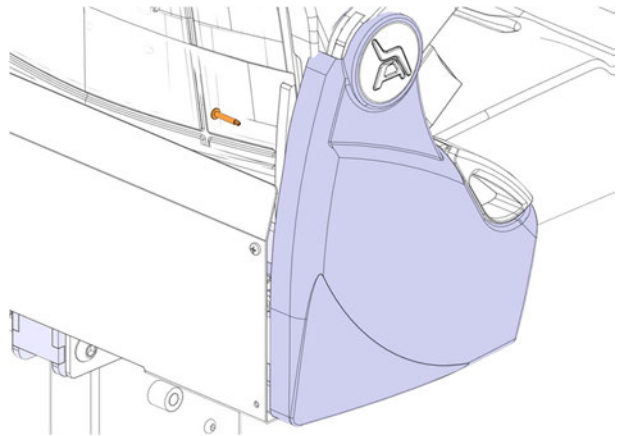

8. Retighten the aisle-side backrest nut (1x) so that it is firmly in place and at least two threads protrude.

**Note: To access the nut, you must flip up the cushion.**

**Note: Do not overtighten and check that the seat backrest tilts easily.**

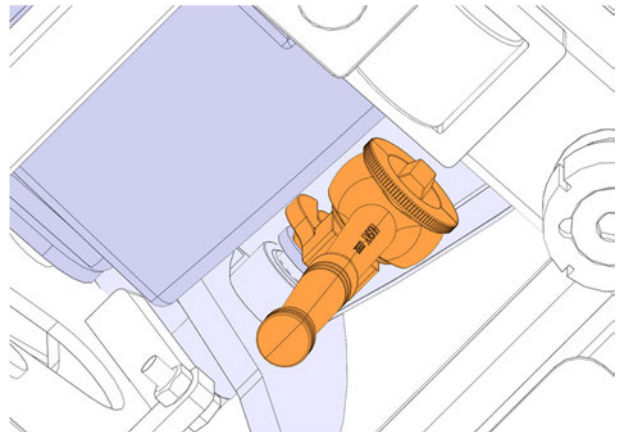

9. Retighten the backrests nut (1x) so that it is firmly in place and at least two threads protrude.

**Note: To access the nut, you must flip up the cushion.**

**Note: Do not overtighten and check that the seat backrest tilts easily.**

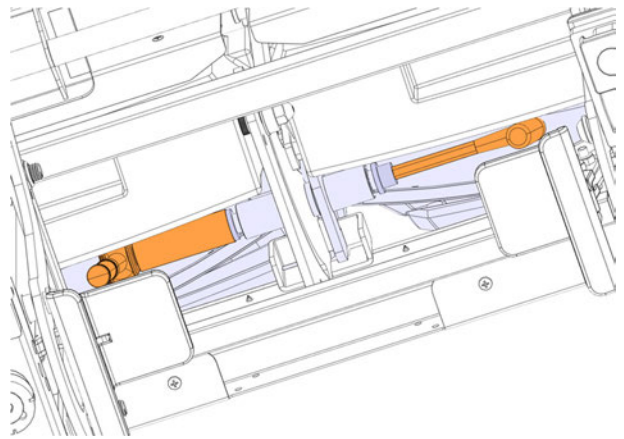

10. Retighten the window side backrest nut (1x) so that it is firmly in place and at least two threads protrude.

**Note: To access the nut, you must flip up the cushion.**

**Note: Do not overtighten and check that the seat backrest tilts easily.**

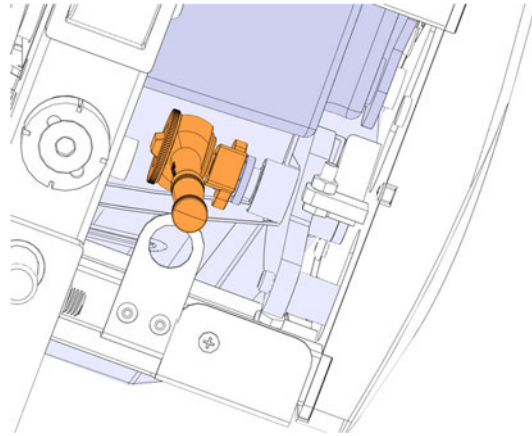

## RETIGHTEN NUTS REAR CROSS SEAT - X3-45 ONLY

1. Remove the nuts (6x) and remove the seat cushions (3x).

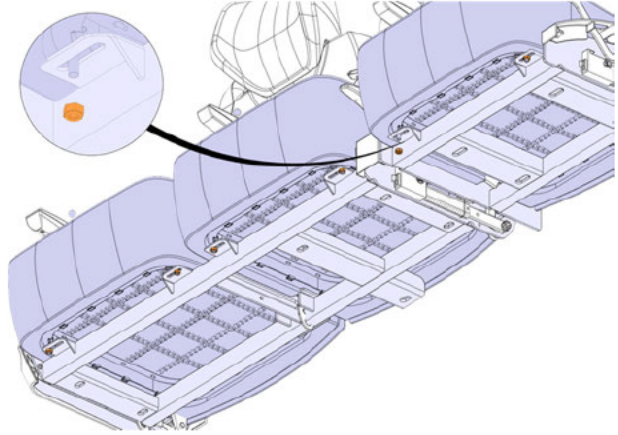

2. Retighten the nut (1x) on the aisle-side seat belt and apply a torque of **32 lb-ft ± 3 lb-ft**.

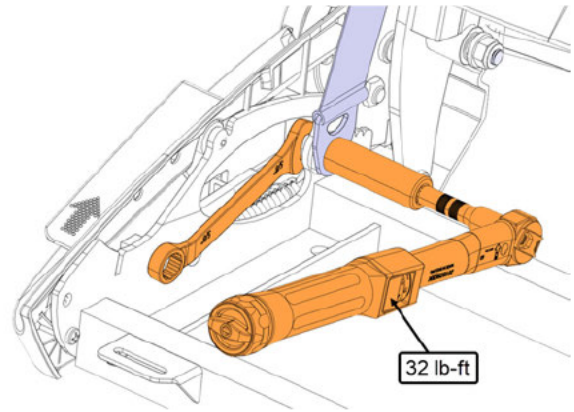

3. Retighten the nut (1x) on the aisle side-seat buckle and apply a torque of **32 lb-ft ± 3 lb-ft**.

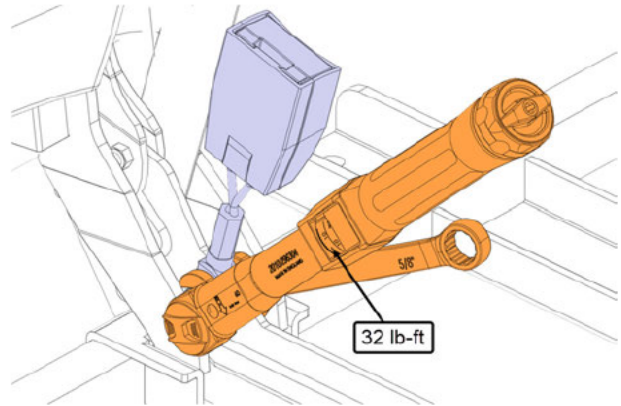

4. Retighten the nut (1x) on the center seat belt and apply a torque of **32 lb-ft ± 3 lb-ft**.

**Note: To access the nut, you must tilt the center backrest.**

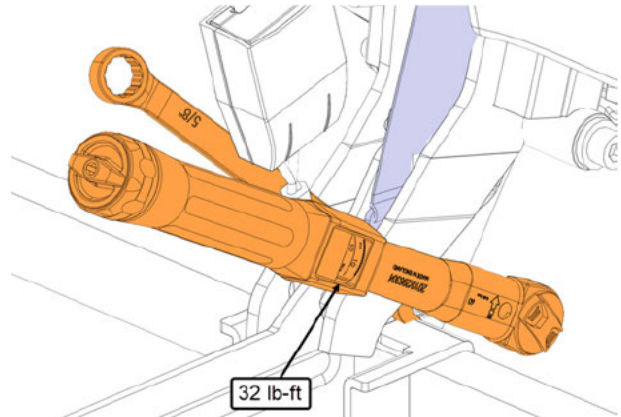

5. Remove the screws (2x) and the nuts (2x) and remove the cover.

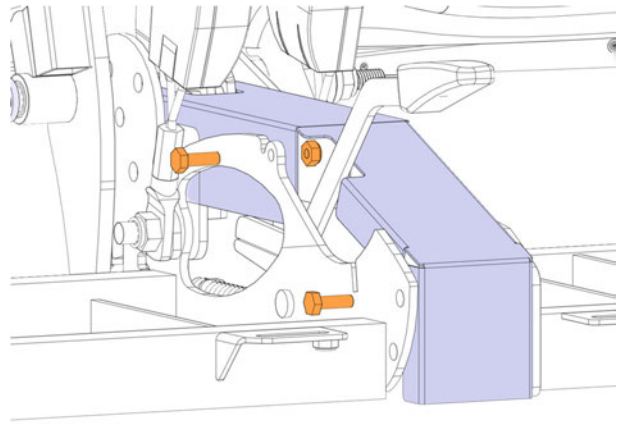

6. Retighten the nut (1x) on the center seat buckle and apply a torque of **32 lb-ft ± 3 lb-ft**.

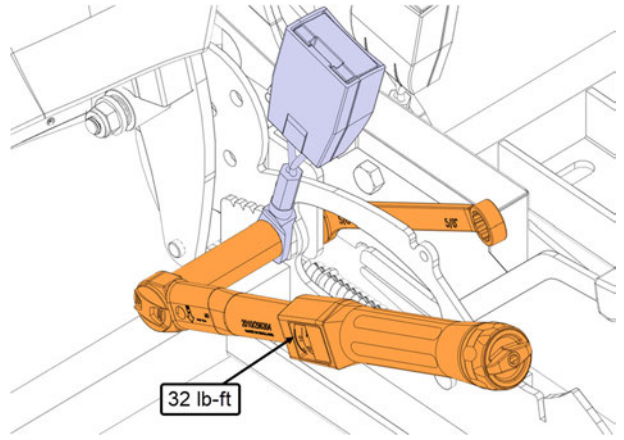

7. Retighten the nut (1x) on the window side seat buckle and apply a torque of **32 lb-ft ± 3 lb-ft**.

**Note: To access the nut, you must tilt the window backrest.**

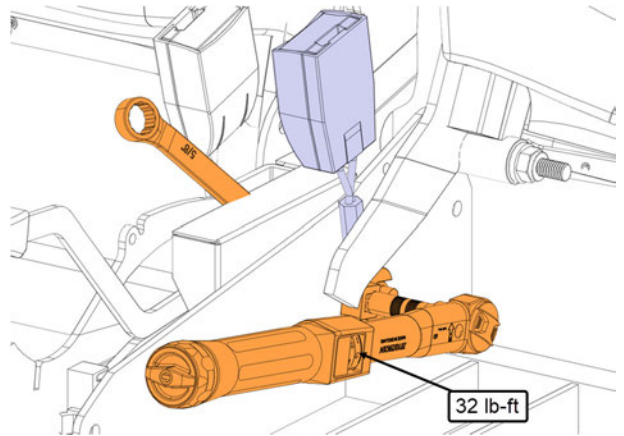

8. Reinstall the cover with the screws (2x) and the nuts (2x).

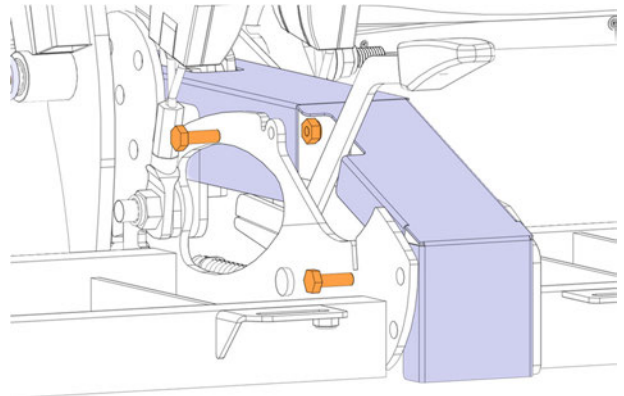

9. Retighten the nut (1x) on the window side seat belt and apply a torque of **32 lb-ft  $\pm$  3 lb-ft**.

**Note: To access the nut, you must pull the plastic finish.**

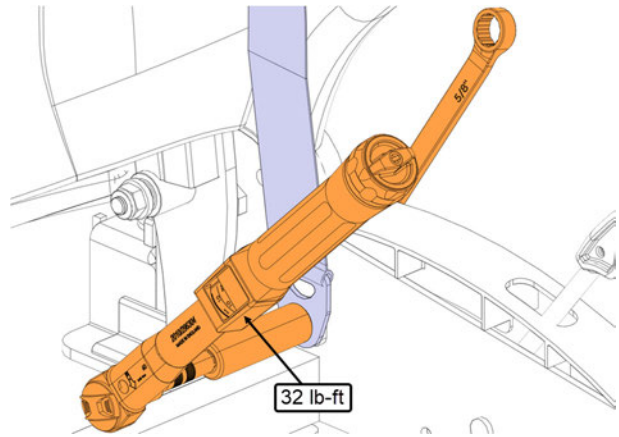

10. Retighten the aisle backrest nut (1x) so that it is firmly in place and at least two threads protrude.

**Note: Do not overtighten and check that the seat backrest tilts easily.**

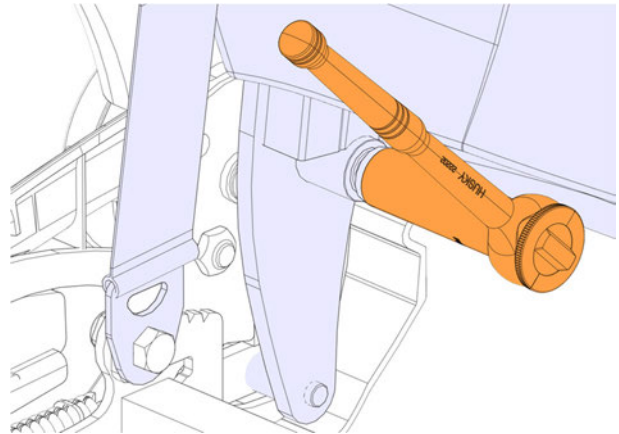

11. Retighten the aisle and the center backrest nut (1x) so that it is firmly in place and at least two threads protrude.

**Note: Do not overtighten and check that the seat backrest tilts easily.**

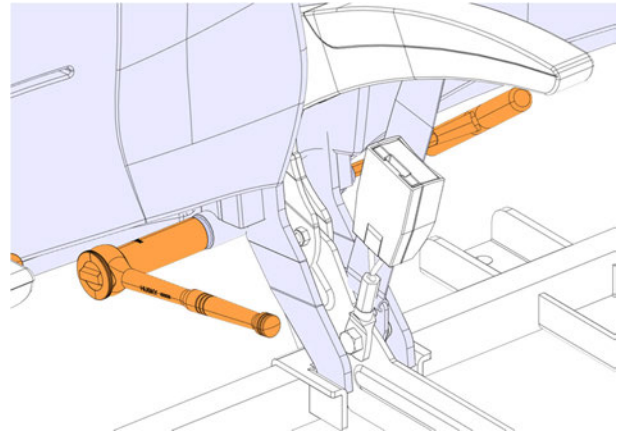

12. Retighten the center seat backrest nut (1x) so that it is firmly in place and at least two threads protrude.

**Note: Do not overtighten and check that the seat backrest tilts easily.**

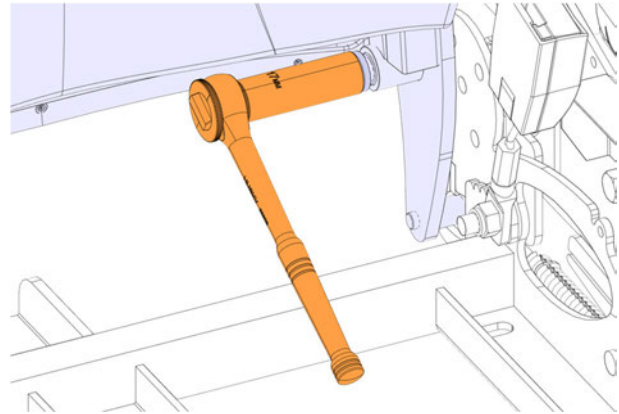

13. Retighten the window seat backrest nut (1x) so that it is firmly in place and at least two threads protrude.

**Note: Do not overtighten and check that the seat backrest tilts easily.**

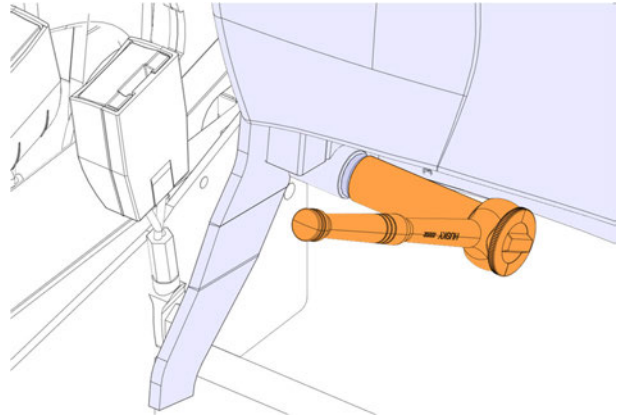

14. Retighten the window seat backrest nut (1x) so that it is firmly in place and at least two threads protrude.

**Note: Do not overtighten and check that the seat backrest tilts easily.**

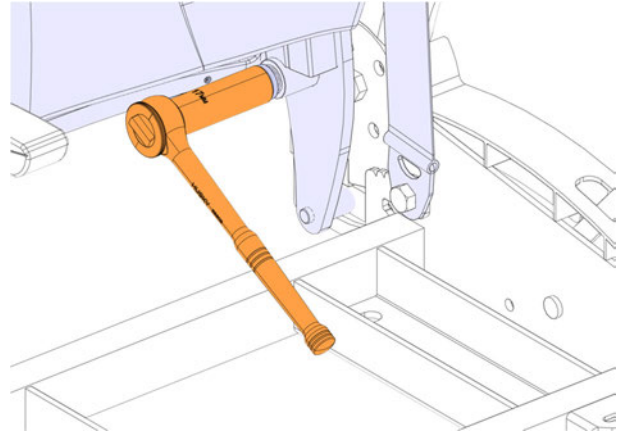

15. Reinstall the cushions (3x) with the nuts (6x), ensuring that the nuts are firmly in place and that at least two threads protrude.

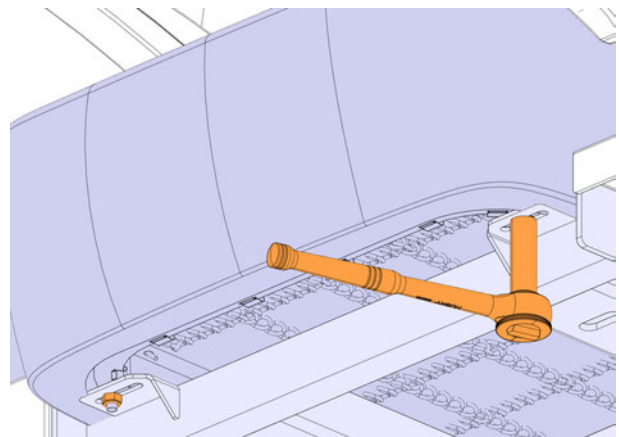

## PARTS DISPOSITION

DO NOT RETURN THE REPLACED PARTS. Discard waste according to applicable environmental regulations (Municipal/State[Prov.]/ Federal)

## WARRANTY

This modification is covered by Prevost's normal warranty. We will reimburse you the parts and labor as follows upon receipt of a completed A.F.A. Please submit claim via our Online Warranty System, available at [www.prevostcar.com](http://www.prevostcar.com) (under service \ warranty section).

- Use Claim Type: "Bulletin/Recall" and select "Safety Recall SR25-23A".

Inspection of the nuts only  
4.5 hours (4,5) of labor

or

Inspection and retightening of nuts  
9 hours (9,0) of labor

Should you only wish to close the safety recall (without reimbursement), fill-in the "Safety Recall Certification Sheet" provided with this bulletin and return it to our warranty department by Email at [prevost.warranty@volvo.com](mailto:prevost.warranty@volvo.com) or by fax at 418-831-9301.

## OTHER

VBC Bulletin	N/A
Fail Code	18.03-2
Defect Code	9
Syst.Cond	R
Causal Part	868909

Access all our Service Bulletins on  
<http://techpub.prevostcar.com/en/>  
or scan the QR-Code with your smart phone.

E-mail us at [prevost.techpub@volvo.com](mailto:prevost.techpub@volvo.com) and type "ADD" in the subject to receive our warranty bulletins by e-mail.



