

## Repair and Inspection Instructions for RUD Set Screws

**Purpose:** To test and torque suspect set screws in the Spring Winder of RUD Operator.

**Tools needed:**

- 7/16 crow foot
- Ratchet Strap
- Curved Jaw Locking Pliers
- Torque Wrench set to 165 in-lbs
- Paint Marker

**Inspection:**

1. Release the latch of the roll up door and allow the door to move to its fully open position.
2. Secure the door using a ratchet strap
  - a. Attach one end of the ratchet strap to the edge of the bottom panel of the RUD door. Hook the other end into an open slot in the band. (See Figure 1.)
  - b. Carefully tighten the ratchet strap until the bottom edge of the door is suspended approximately 1 foot away from the header. This action provides safe working clearance. (See Figure 2.)

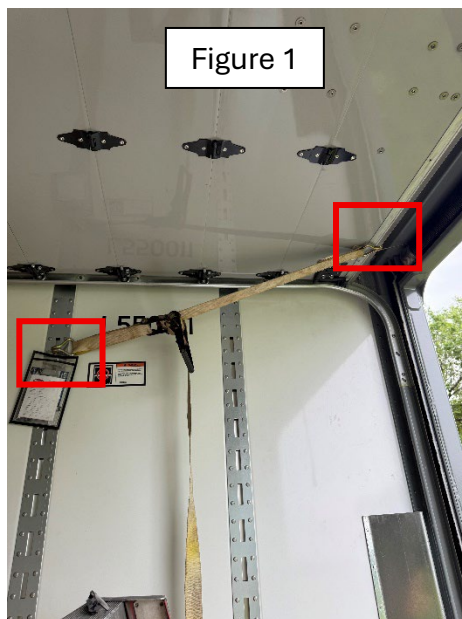

## Repair and Inspection Instructions for RUD Set Screws

3. Install a secondary safety restraint: Clamp the curved jaw locking pliers securely to the door track directly in front of one of the RUD rollers. (See figure 3.)



Figure 3

4. Torque the Set Screws
  - a. Locate the two set screws on the RUD Spring winder (See figure 4)
  - b. Set your inch-pound torque wrench to 165 inch-lbs.
  - c. Using the 7/16 crow foot attached to the torque wrench apply steady pressure to the set screw until the torque wrench clicks
    - i. Note: If a set screw turns significantly before reaching the specified torque, it likely indicates it was under torqued. Take note of vin(s) that were under torqued and report information back to the warranty team.

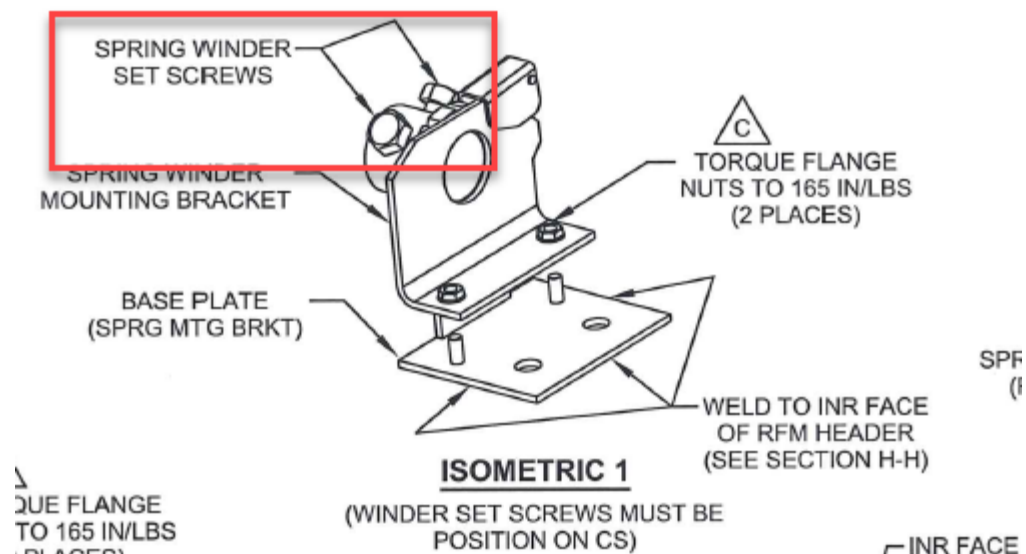

Figure 4

## Repair and Inspection Instructions for RUD Set Screws

5. Take a paint marker and witness mark the set screw head to the collar. This mark provides a visual indication for future inspections, allowing quick identification of any loosened fasteners. (See figure 5)



6. Release the vice grips and release the ratchet strap
7. Close and latch door