

SAFETY RECALL

Mack Trucks Inc.
Greensboro, NC USA



Date	Number	Release	Page
08.2025	SC0481	01	1(21)

MMD Electric FMVSS 124 Return to Idle MD6 BE, MD7 BE

RECALL INFORMATION

Mack Truck has determined that certain MMD (Electric) vehicles may not be compliant with FMVSS 124. In the event of a Vehicle Controller Area Network (CAN) failure, the throttle signal from the electro mobility control unit would retain the last known throttle setting and would not return idle (except during service brake application) increasing the risk of a crash.

To ensure these trucks meet Mack's stringent safety requirements, an inspection of the EXRO interface connector will be performed and re-pinned if necessary and the General Vehicle Control Unit (GVCU) will be reprogrammed with software that ensures compliance with FMVSS 124.

VEHICLES AFFECTED

Certain Mack MMD Electric vehicles manufactured between June 22, 2023, and February 17, 2025.

VEHICLE QUANTITY

There are 162 vehicles affected by this recall. (148 U.S., 14 Canada)

Required Software Application

To update the GVCU software, you'll need an application called cvFlash. If you haven't already downloaded it to your PC, please access the cvFlash file and download instructions in the Trucks Dealer Portal. The images below show where to find the files in TDP.

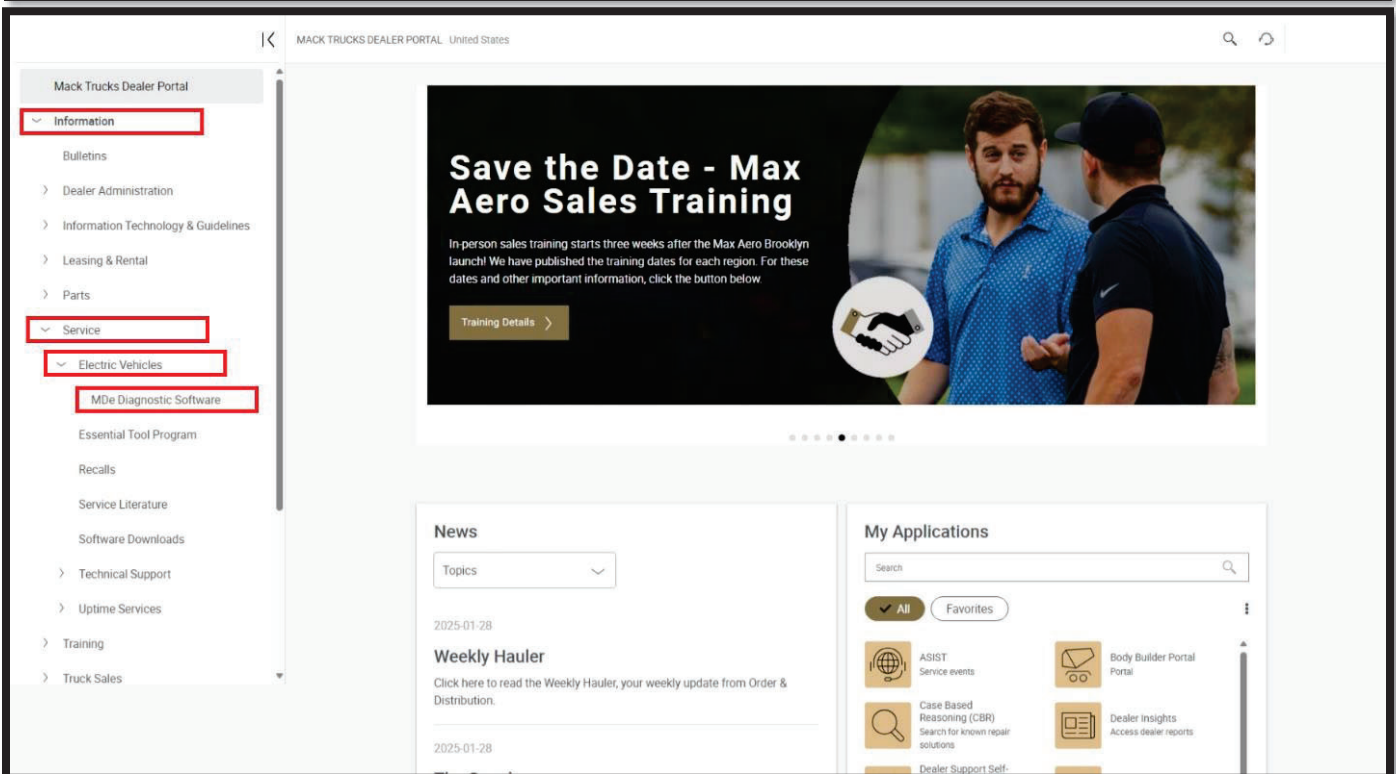
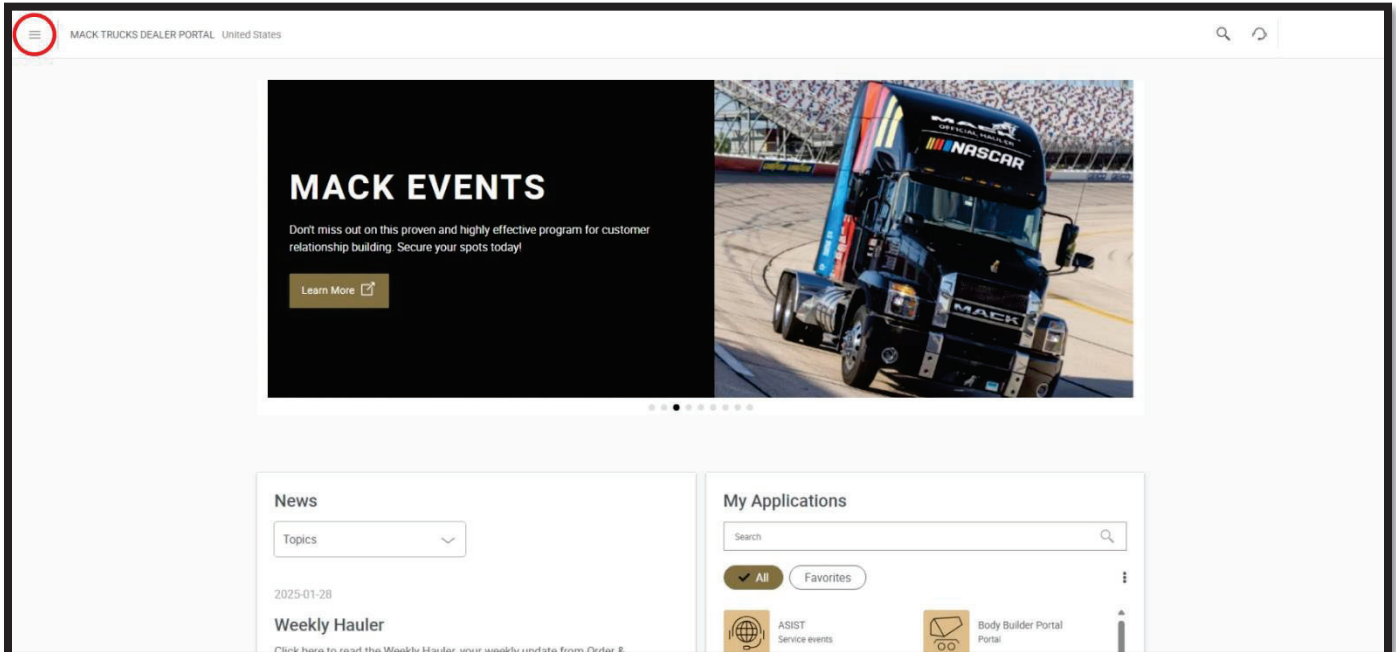

MACK TRUCKS DEALER PORTAL United States

Mack Trucks Dealer Portal > Information > Service > Electric Vehicles > MDe Diagnostic Software

MDe Diagnostic Software



Date	Name
11/18/2024	Setup CV flash
11/18/2024	Code Meter Runtime
11/18/2024	PCAN view
11/18/2024	Peak Oem drv
11/18/2024	U6upper Technician Setup x86 version 2023-11-08
11/18/2024	DO1263 How to Install and Use UDAN
11/18/2024	DO1262 How to Install and Use CVflash
11/18/2024	DO1264 How to Install and Use PCAN

Download file

Download Instructions

Required Tools and Equipment

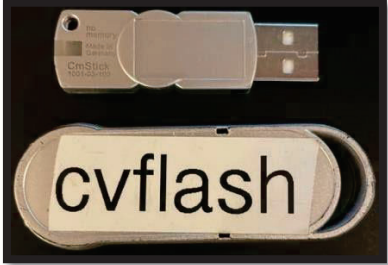
All tools and equipment listed below are essential tools for BEV dealers and are needed to complete this recall. If you do not already have them, they can be ordered through Parts LinQ. Dealer is responsible for essential tool cost and will NOT be covered by this campaign.

Description	Part Number	Image
CV Flash License	88800874	
PCAN USB Dongle	88800873	
PCAN Harness	88800876	
SEA Diagnostic Harness	88800877	

eService Case

To receive the software file needed you will need to create an eService case under Emobility Technical Support. Please include the following.

- Recall number SC0481 and title (Mack MMDE FMVSS 124 Software)
- VIN number

Important Note
An eService case is required for every truck, even if your dealer is performing this campaign on multiple trucks.

Important Note
Note the title of the file received and save it to a known location on your PC where you can easily access.

Repair Instructions

1. Secure vehicle for service by parking on a flat and level surface.
2. Apply parking brake.
3. Place the transmission in neutral or park.
4. Turn the ignition to the “OFF” position.
5. Turn battery disconnect to the “OFF” position.
6. Install the wheel chocks.

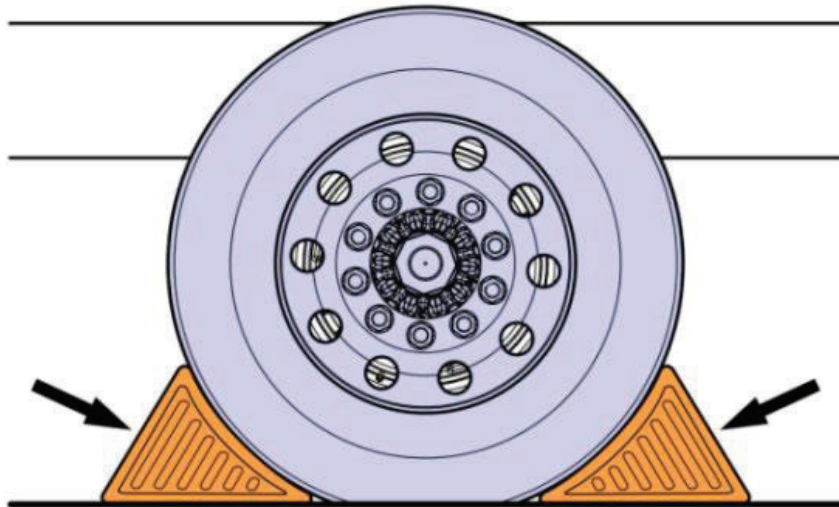

7. Remove the four screws and parking brake nob circled below.



8. Remove switch panel cover.



9. Remove the six screws circled below.



10. Lay the switch panel out of the way.

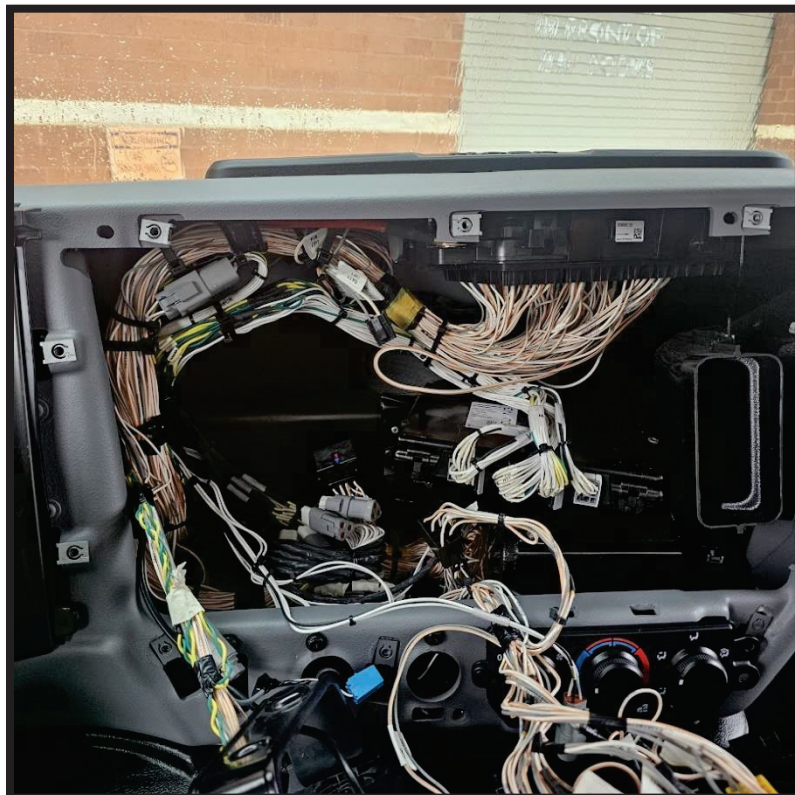

11. Locate the EXRO interface connector. It is a 12-pin gray connector labeled SEAVCU.

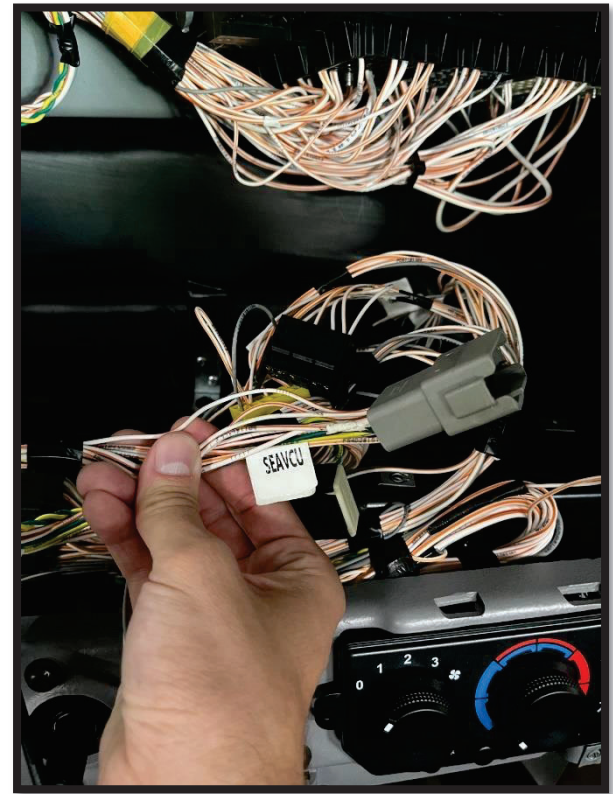
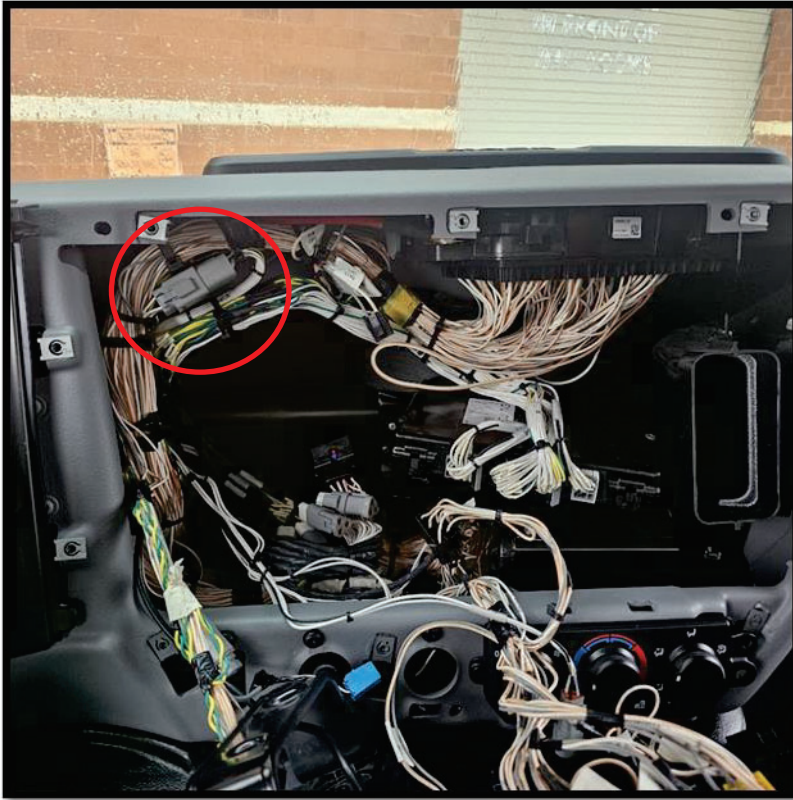

12. Remove zip ties and disconnect the connector for better access.

13. Locate cavities 7 and 9 of the connector. Ensure that you are locating the cavities at the connector that has the SEAVCU label.

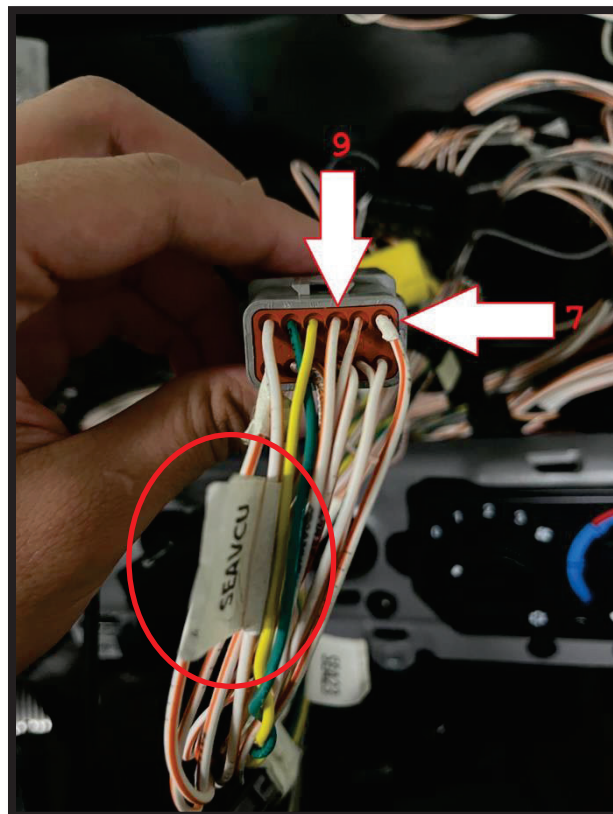

14. Check the wire ID printed on the wires in cavity 7 and 9.

- Cavity 7 should have ID CA3A3,
- Cavity 9 should have ID CB8A3.

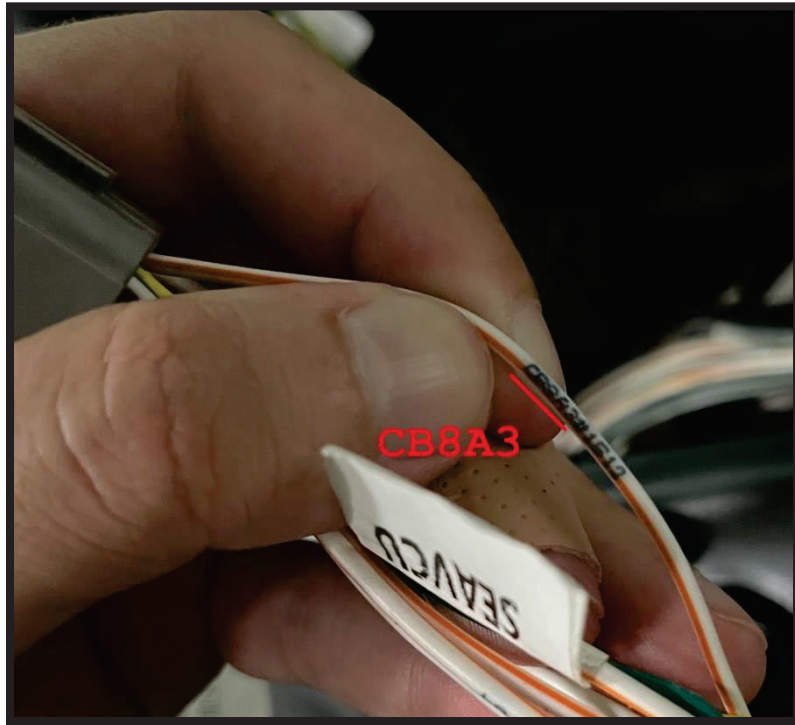

15. If correct continue to step 17.

16. If incorrect, relocate the wires by following the steps below.

- Disconnect connector
- Remove inner lock



- Release lock at pin 7 and 9 (one at a time)
- Remove pin 9 and place in cavity 7
- Remove pin 7 and place in cavity 9
- Return to step 14 to verify the correct wire ID is in the correct cavity

17. Reconnect the SEAVCU connector and zip tie back to original location.
18. Follow steps 6 through 9 in reverse to put the dash back together.
19. Connect the cvFlash license flash drive to your PC.



20. Connect the PCAN USB dongle to your PC.



21. Connect the PCAN harness to the PCAN box.



22. Connect the other side of the PCAN harness to the connector labeled CAN 1 on SEA diagnostic harness.



23. Remove the access panel.

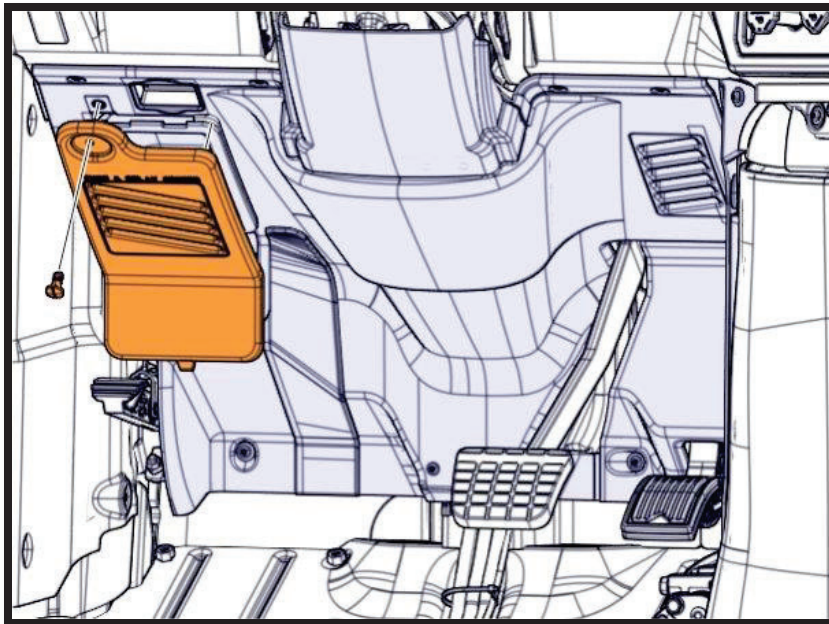

24. Locate the 12 pin SEA diagnostic plug located inside of the access panel.

Important Note

If you cannot locate the SEA diagnostic connector via the access panel, removal of the kick panel may be necessary.

25. Connect the diagnostic plug to the SEA diagnostic harness.

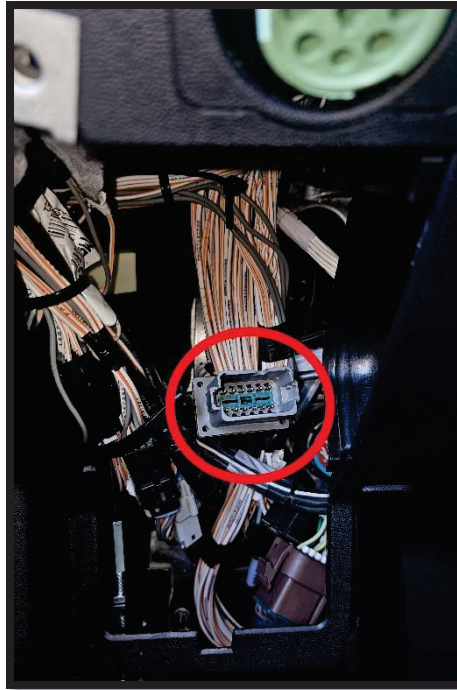

26. Open cvFlash on your PC.

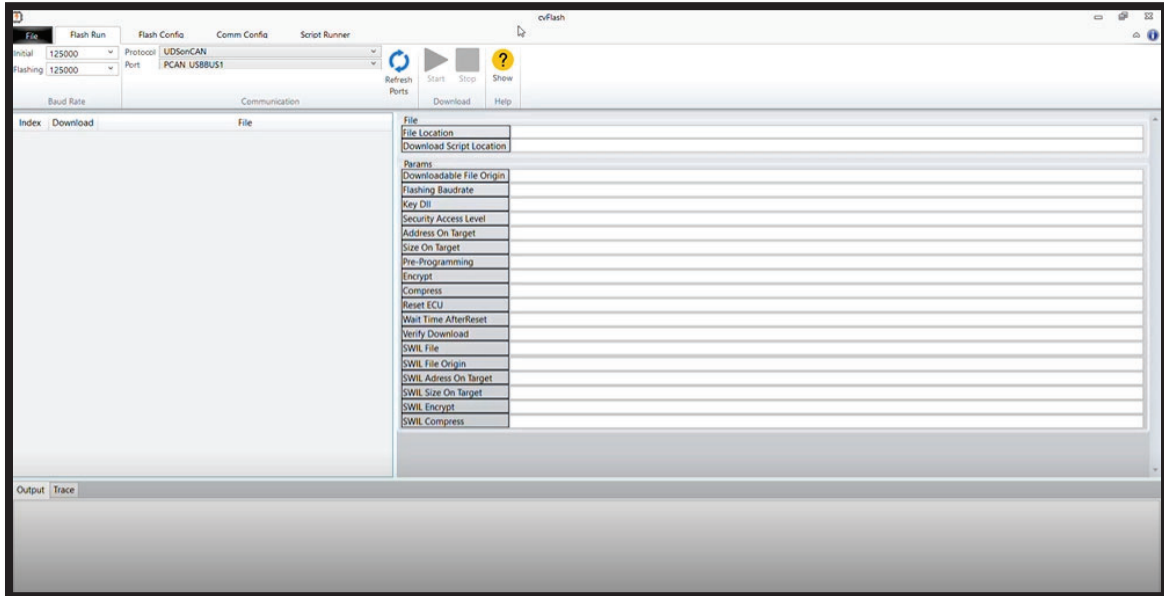

27. Open the File tab and click on Open Project Package.

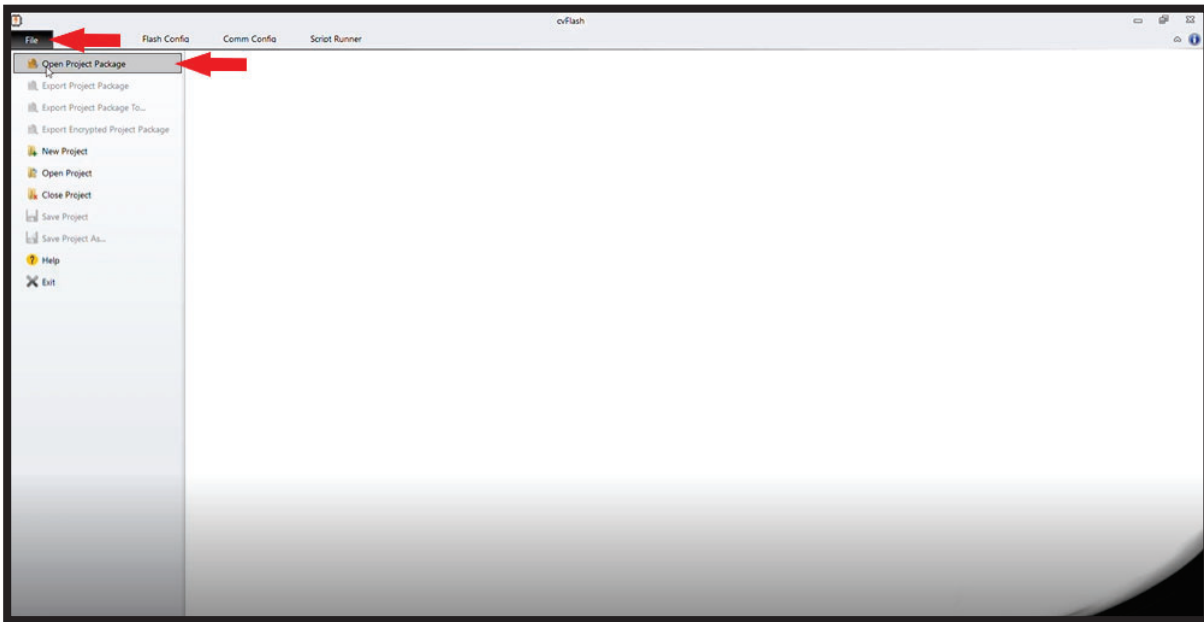

28. Locate and select the save file received from eService.

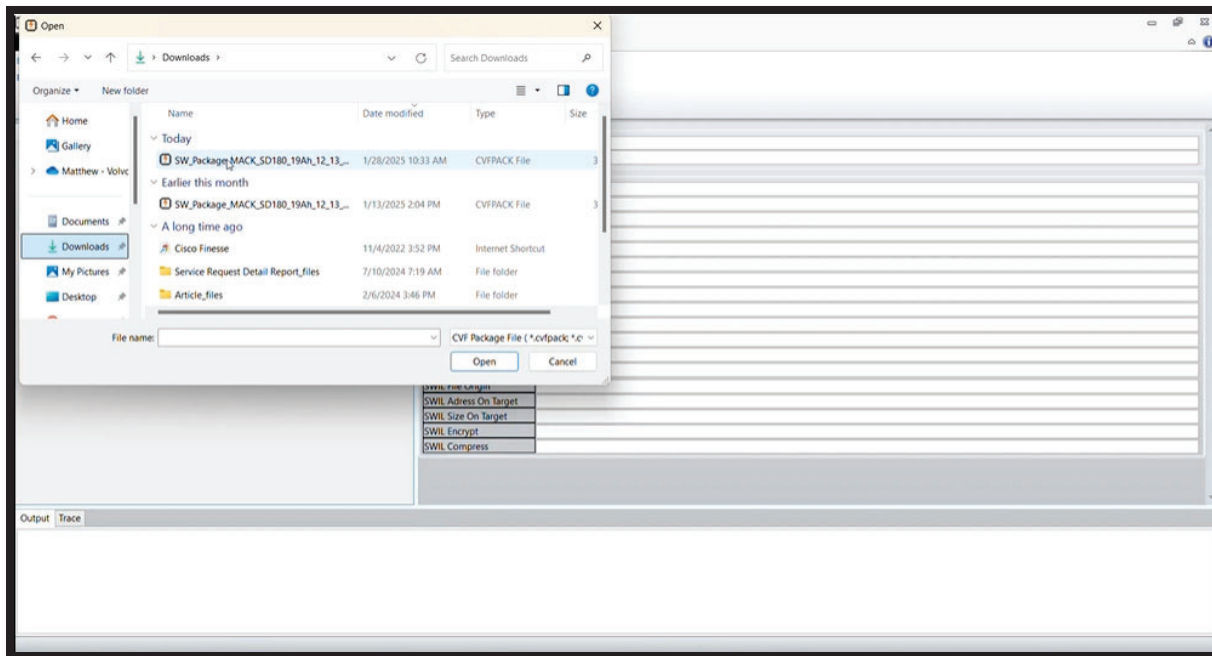

29. You should now see the 'Flash Run' sub-menu populated with information. If no information is populated, repeat steps 27 and 28.

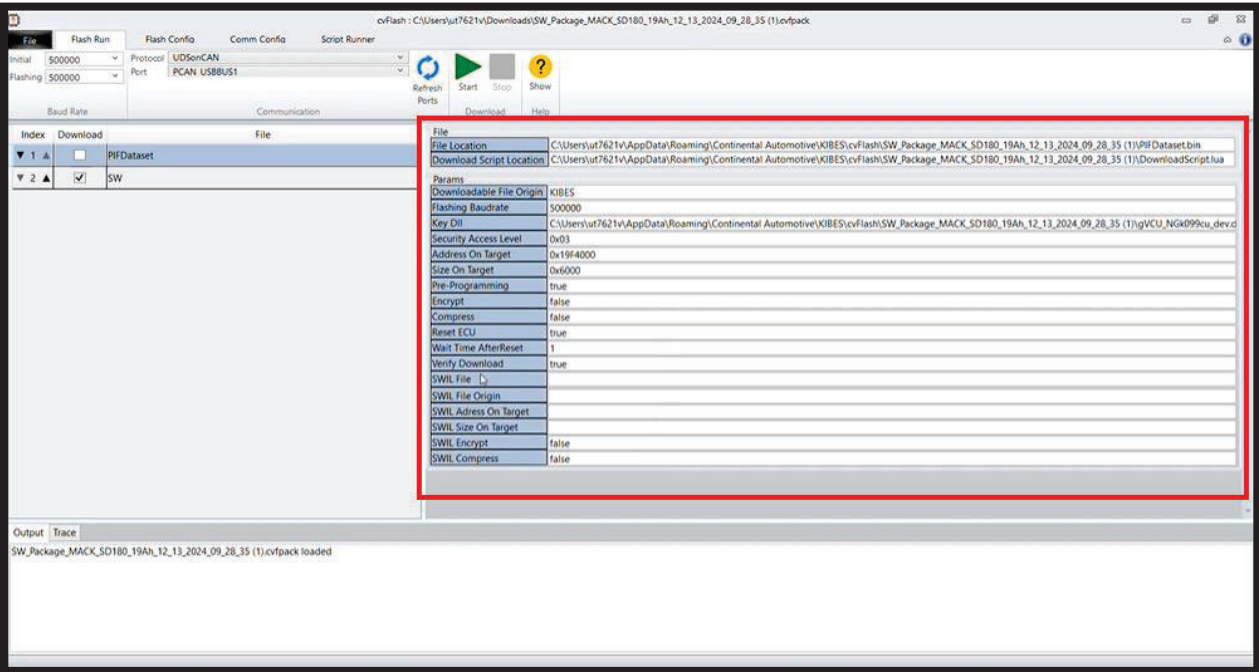

30. Confirm that the drop-down menu next to "Initial" (Outlined in red below) is set to 500000.

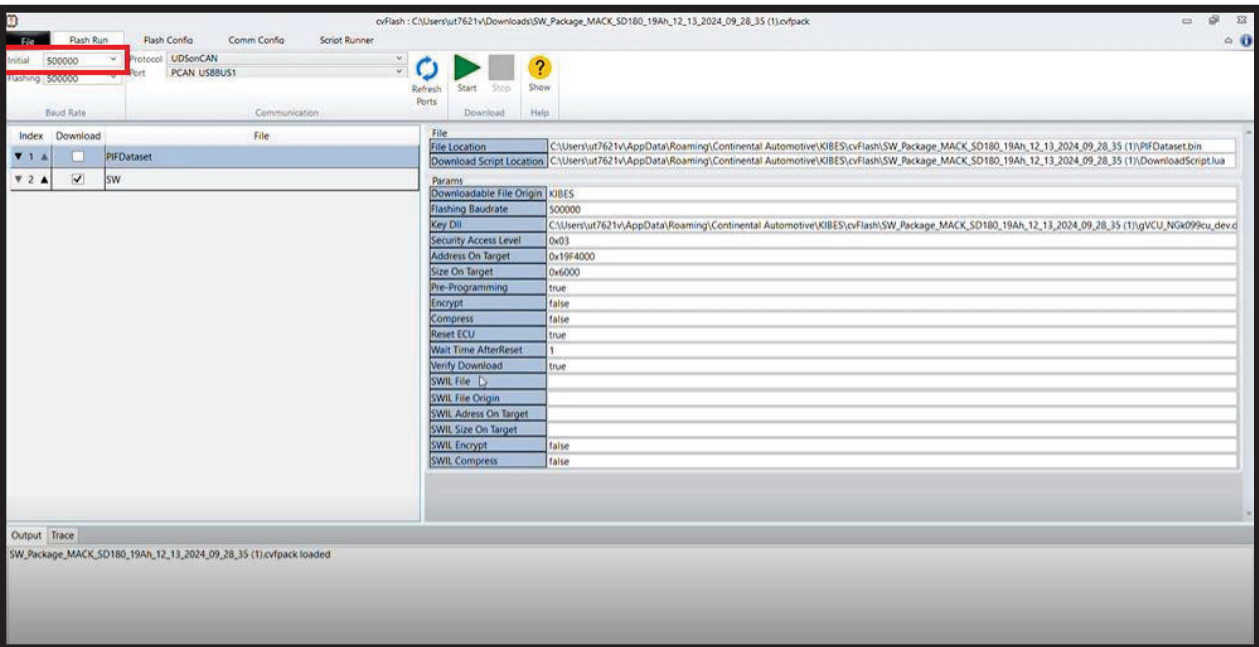

31. Select the Comm. Config tab.

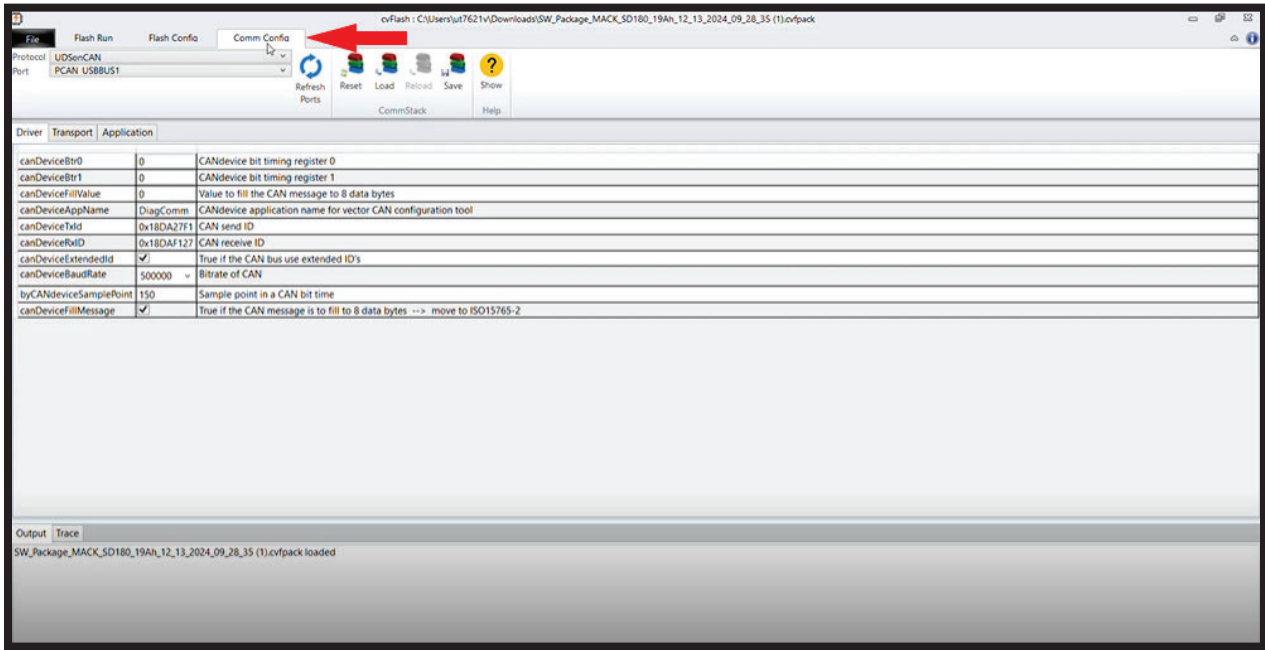

32. Ensure that UDSonCAN is selected in the "Protocol" drop-down, and PCAN USBBUS is selected in the "Port" drop-down.

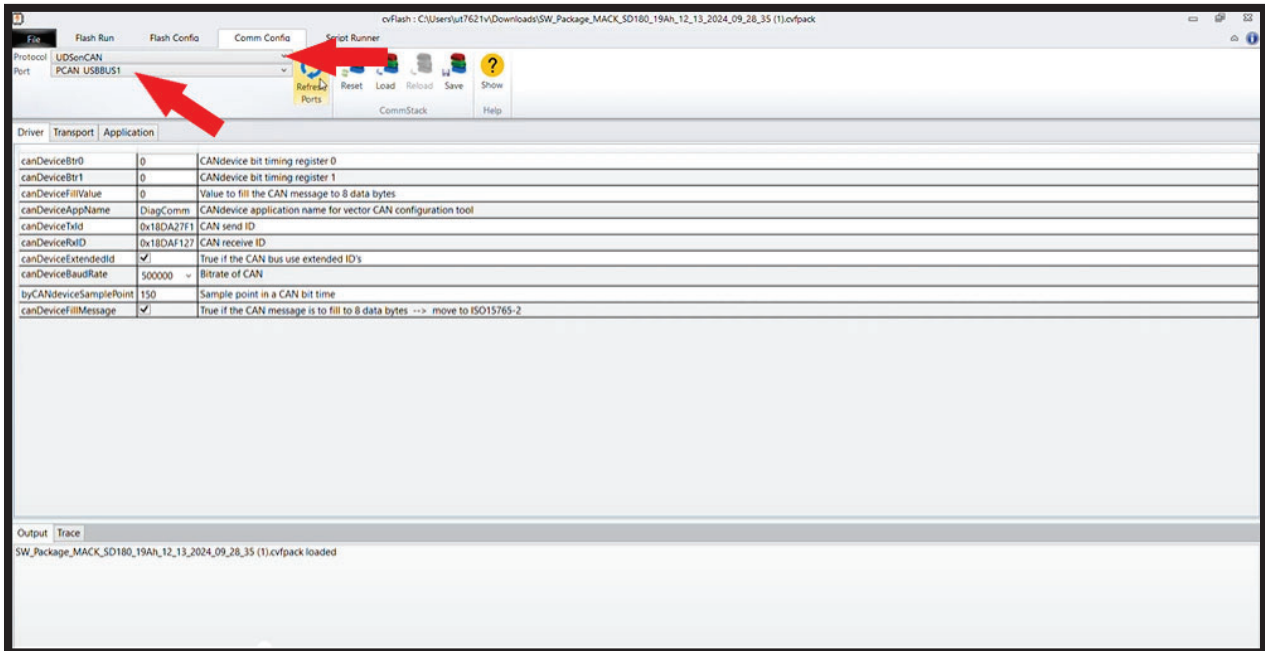

33. Click “Refresh Ports”.

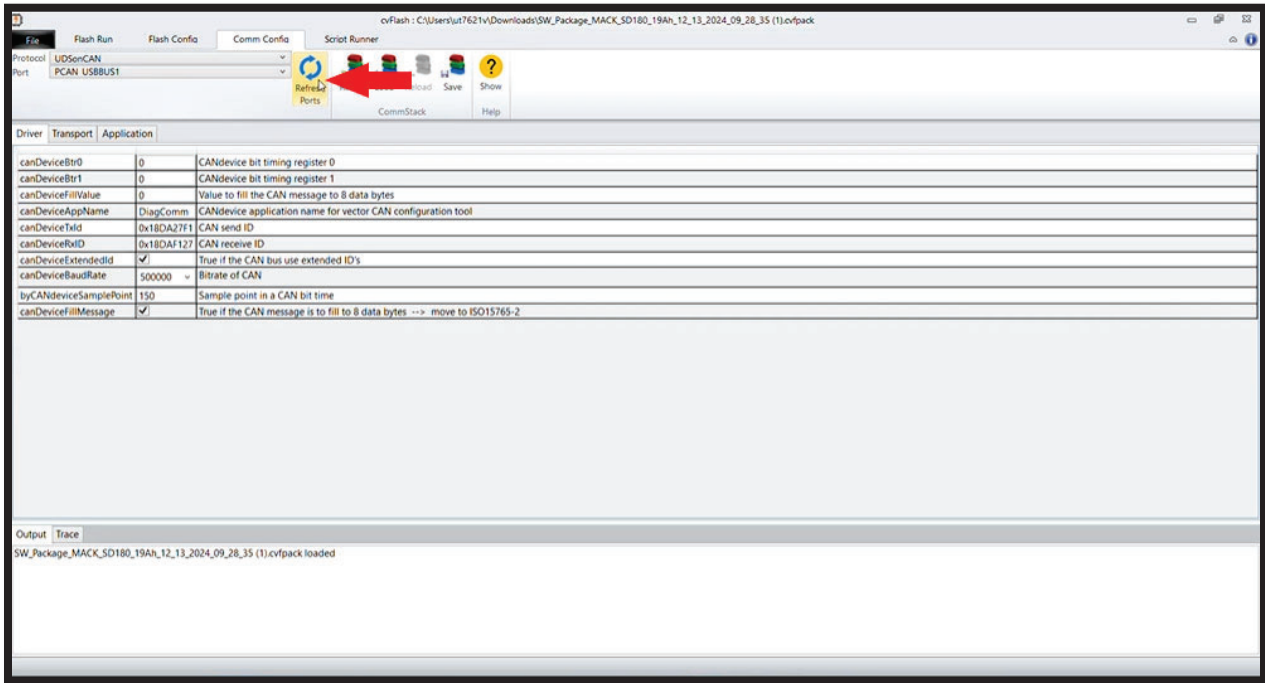

34. Check to ensure that the canDeviceTxID and canDeviceRxID values in the “Driver” tab are correct. They should both begin with 0x18. If you see 0x98, change the nine to a one.

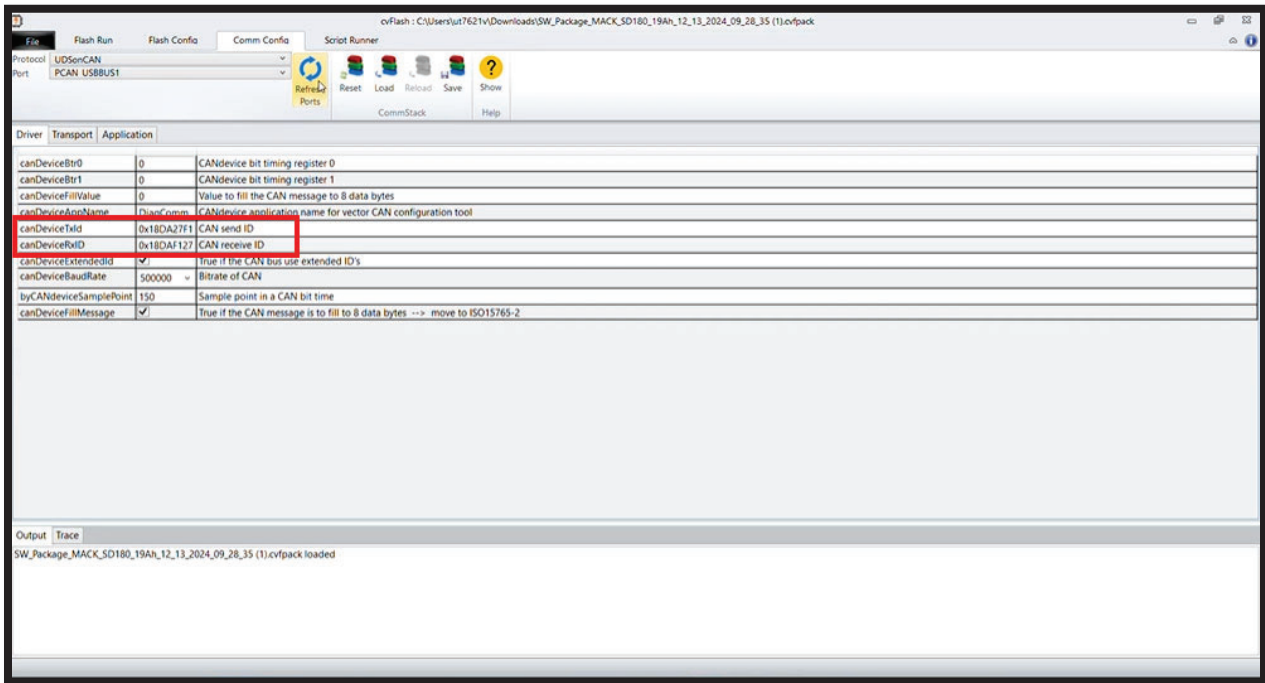

35. Select the Flash Run tab.

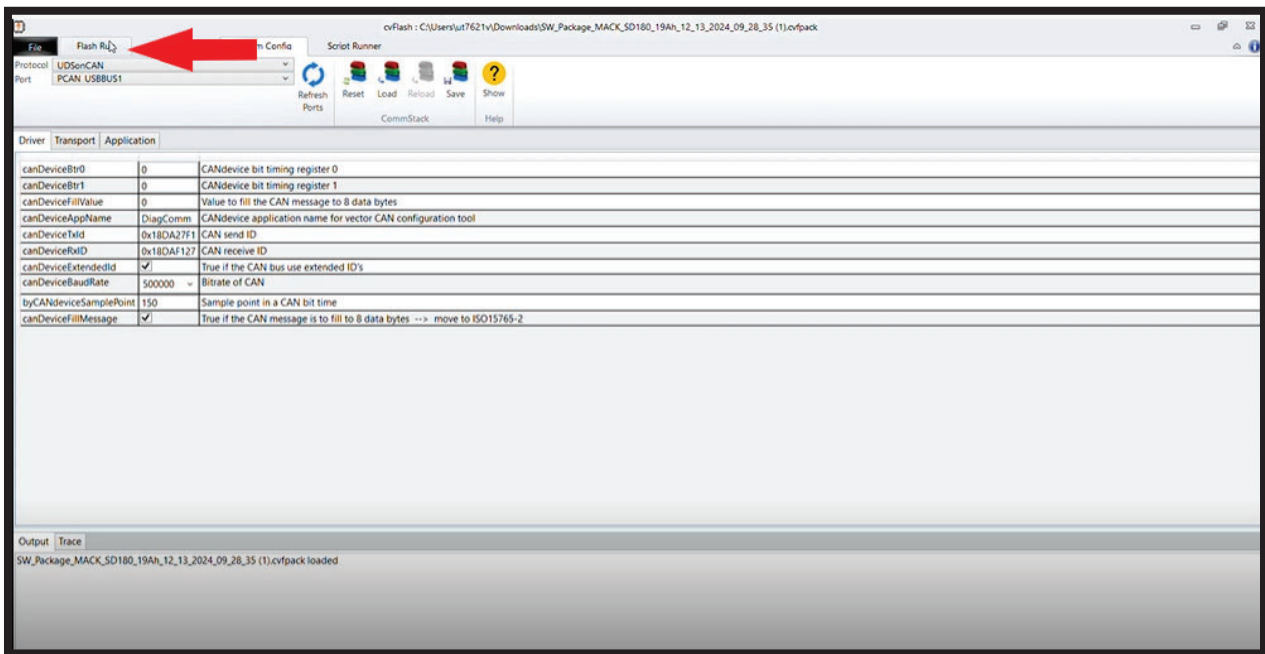

36. Turn battery disconnect to the "ON" position.

37. Turn the ignition key to the "ON" position.

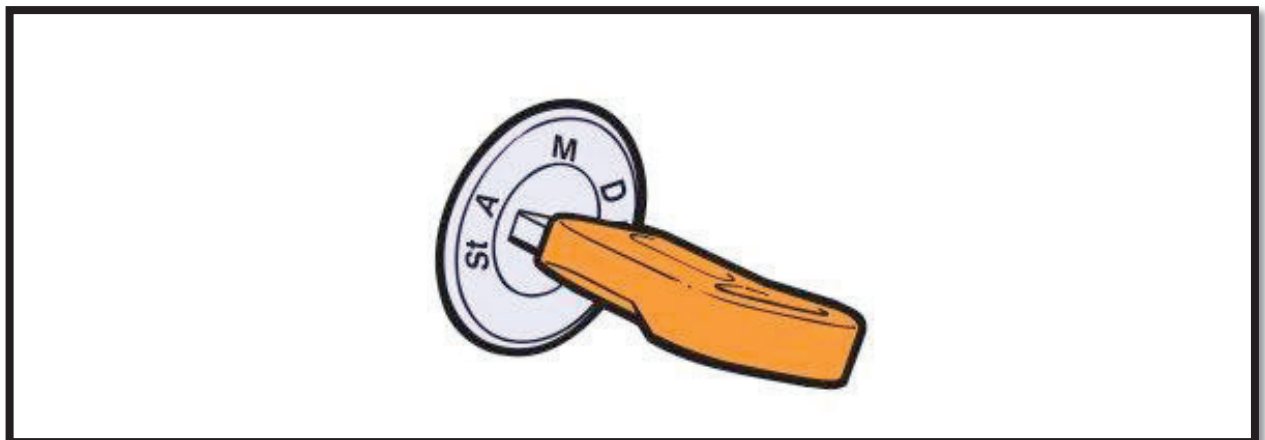

38. Select “Start” in the Flash Run tab.

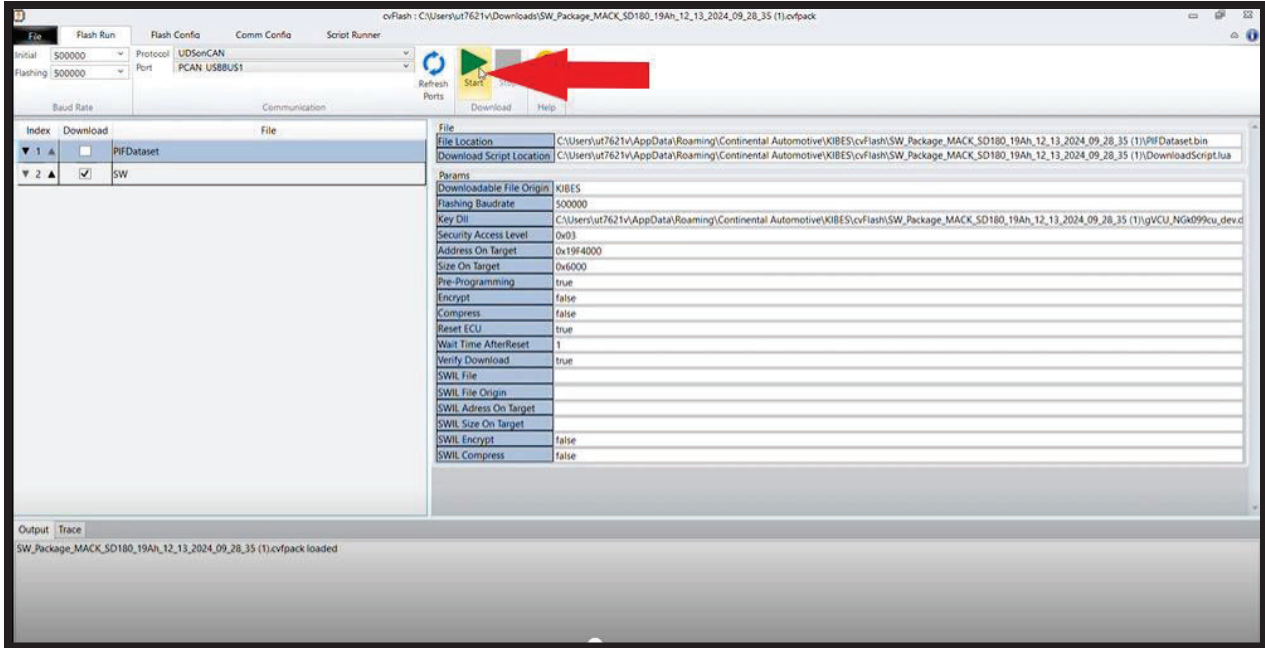

39. Once the flash procedure has started, a progress bar will appear. Pictured below.

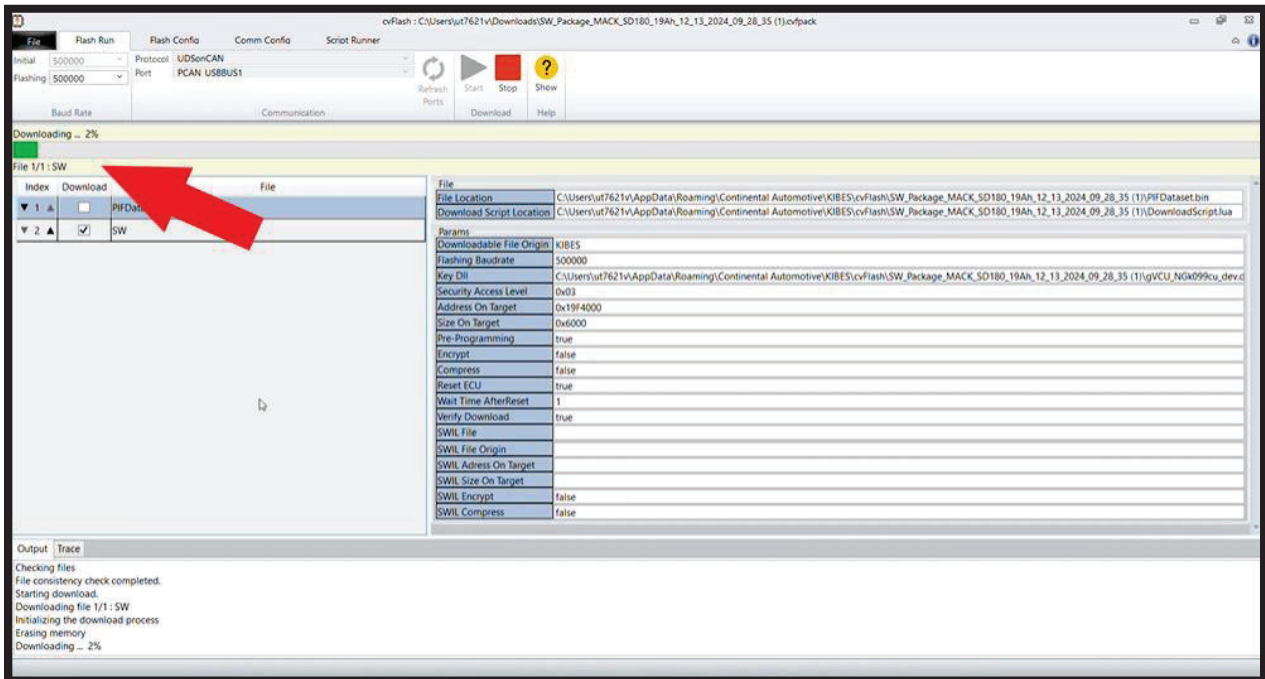

40. Once the status bar has reach 100% the message “Validating Download” will appear above the status bar (Image One). DO NOT exit at this point. The flashing procedure is not complete until the status bar goes away and the message “Download completed Successfully” appears in the bottom lefthand corner (Image Two).

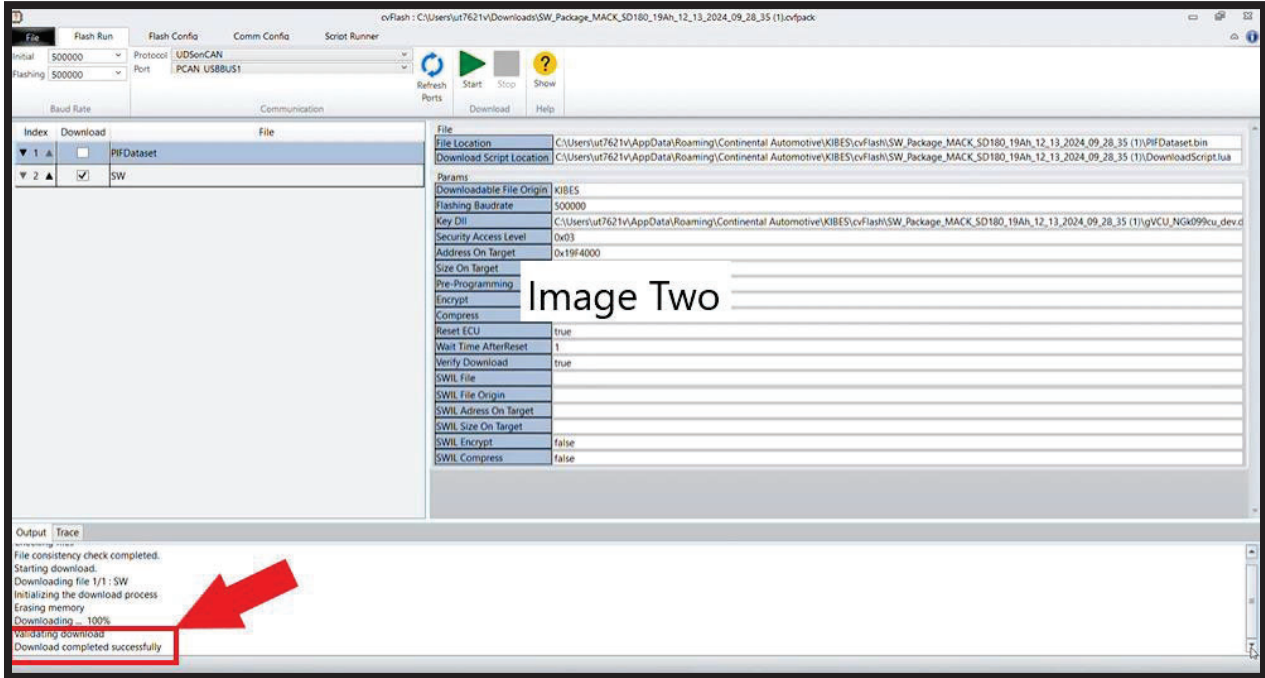

Image Two

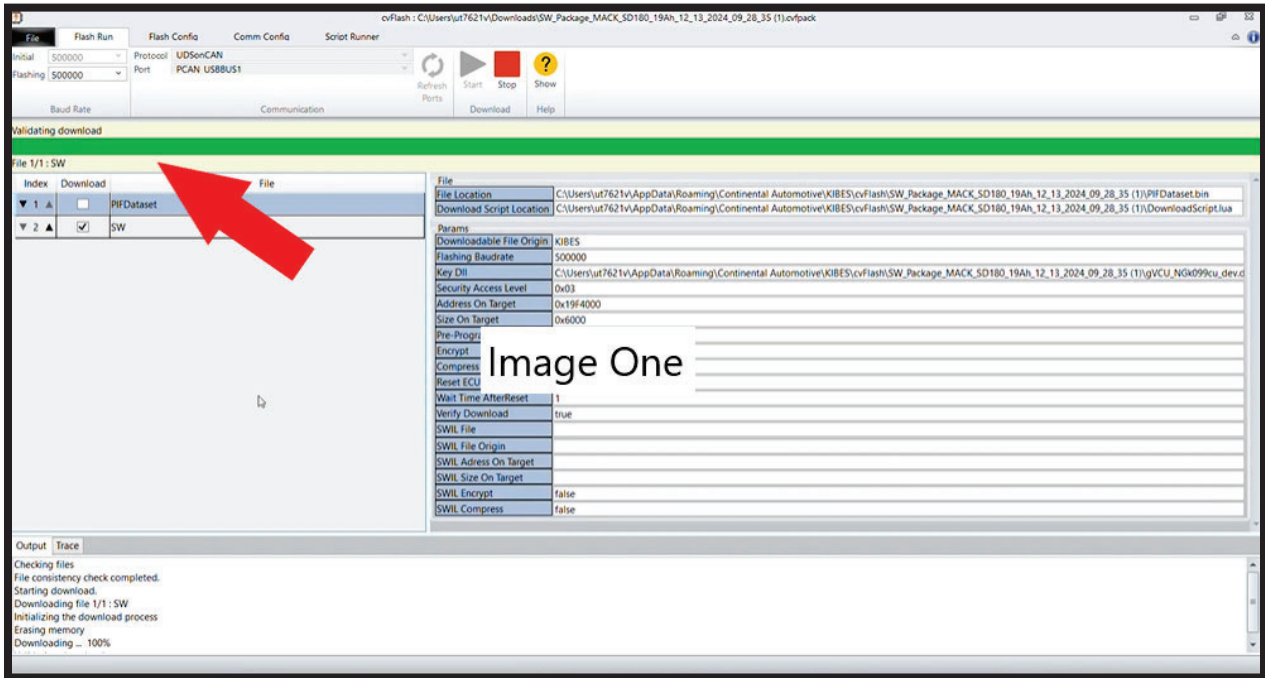

Image One

41. Exit cvFlash.

42. Turn ignition key off.

43. Wait 10 seconds.

44. Turn ignition key on.

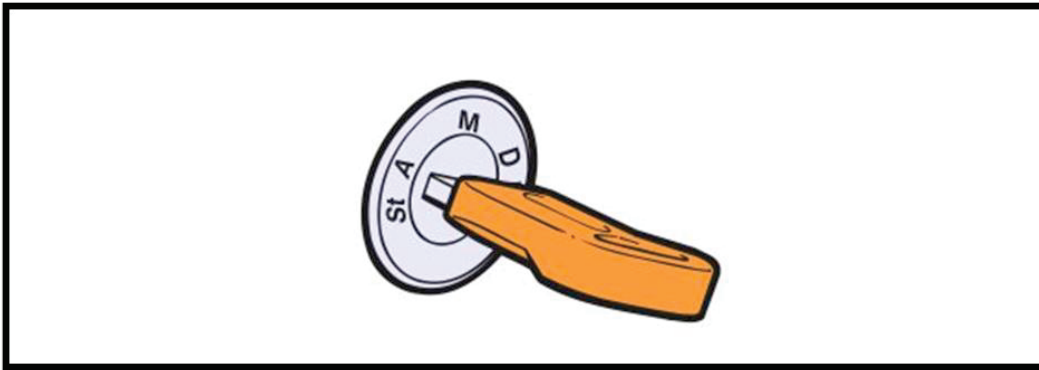

45. Remove the wheel chocks.

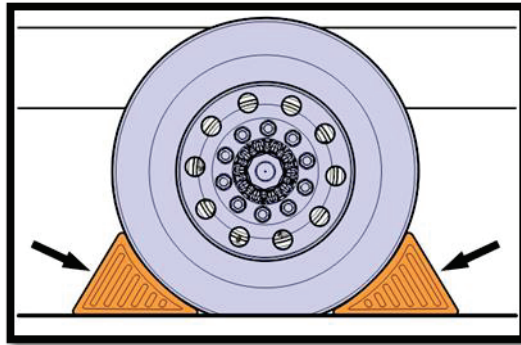

46. Release the truck.

REIMBURSEMENT

This repair is covered by an authorized Safety Recall. Reimbursement is obtained through the normal claim handling process.	
	UCHP Reimbursement
Claim Type (used only when uploading from the Dealer Business System)	40
Recall Status	
Vehicle repaired per instructions	1-Modified per instructions
Main Labor Code	
1700-22-03-11 Campaign Programming (0.1x6)	0.6
Labor Code	
1720-16-09-01 Campaign General (0.1x4)	0.4
Causal Part	24444477
Authorization Number	C0467

Note: Dealers are to perform Safety Recalls on all subject vehicles at no charge to the vehicle owner regardless of mileage, age of vehicle or ownership (original purchaser or subsequent purchasers). Whenever vehicles are subject to a Safety Recall are brought to your dealership for service, it is strongly recommended that every effort be made to perform the recall correction before the vehicle is released to the owner.