



PREVOST

SAFETY RECALL

SR25-13

DATE:	June 2025	SECTION: 16 SUSPENSION
SUBJECT:	RETORQUE IFS LOWER CONTROL ARM BOLTS	



First Release

mm-jj-yyyy

APPLICATION

NOTICE TO SERVICE CENTERS

*Verify vehicle eligibility by checking warranty bulletin status with **SAP** or via **ONLINE WARRANTY SYSTEM** available on Service / Warranty tab of PrevoSt website.*

Model	VIN	
X3-45 VIP commercial use Model Year: 2025		

This Safety Recall does not necessarily apply to all the above-mentioned vehicles. Some vehicles may also have been modified before delivery. The owners of the vehicles affected by this recall will be advised by a letter indicating the Vehicle Identification Number (VIN) of each vehicle concerned.

DESCRIPTION

On vehicles affected by this recall, the bolts securing the front lower control arms may not have been properly tightened, potentially resulting in the separation of the control arms.

SAFETY PRECAUTIONS

- Eye protection should always be worn when working in a shop.
- Rules for Personal Protection Equipment should always be respected. Wear your PPE including but not limited to the following:



Safety First!



PROCEDURE



DANGER

Park vehicle safely, apply parking brake, stop the engine. Prior to working on the vehicle, set the ignition switch to the OFF position and trip the main circuit breakers equipped with a trip button. On Commuter type vehicles, set the battery master switch (master cut-out) to the OFF position.

Lockout & Tag out (LOTO) must be performed during set-up, maintenance or repair activities. Refer to your local procedure for detailed information regarding the control of hazardous energy.

RETORQUE IFS LOWER CONTROL ARM BOLTS

1. Lift the vehicle and support it on jack stands.

NOTE

Refer to MI18-18 for detailed information on hoisting procedure.

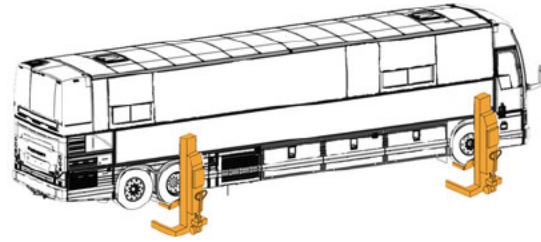

2. Locate the four bolts securing the lower control arms of the front suspension to the backbone.

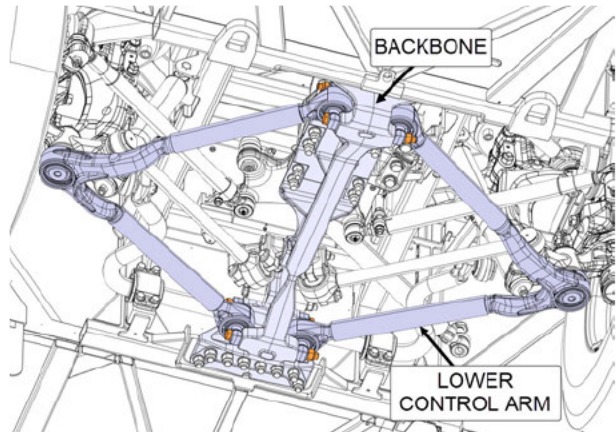

3. Torque each bolt to **387 lb-ft**.
4. Apply red torque seal mark.

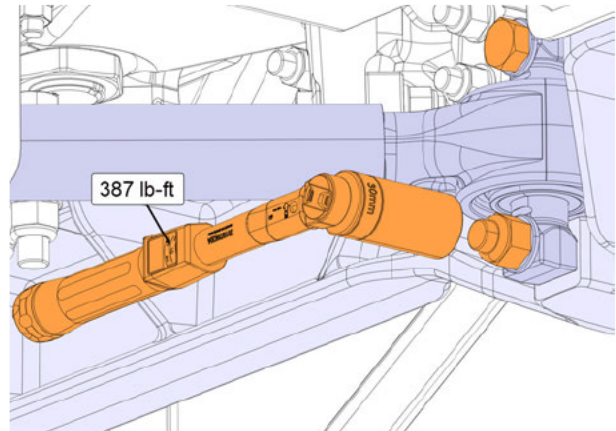

5. Lower the vehicle.

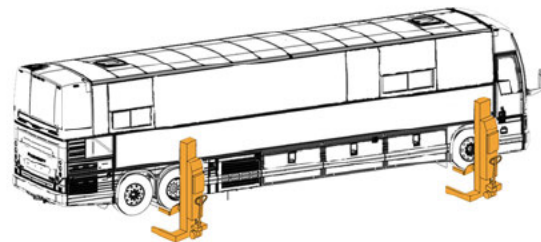

PARTS DISPOSITION

Discard waste according to applicable environmental regulations (Municipal/State[Prov.]/ Federal)

WARRANTY

This modification is covered by Prevo's normal warranty. We will reimburse you 1.0 hour of labor upon receipt of a completed A.F.A. Please submit claim via our Online Warranty System, available at www.prevo.com (under service \ warranty section).

- Use Claim Type: "Bulletin/Recall" and select "Safety Recall SR25-13".

Should you only wish to close the safety recall (without reimbursement), fill-in the "Safety Recall Certification Sheet" provided with this bulletin and return it to our warranty department by Email at prevo.warranty@volvo.com or by fax at 418-831-9301.

OTHER

VBC Bulletin	N/A
Fail Code	16.07
Defect Code	09
Syst.Cond	R
Causal Part	24666089

Access all our Service Bulletins on <http://techpub.prevo.com/en/> or scan the QR-Code with your smart phone. E-mail us at prevo.techpub@volvo.com and type "ADD" in the subject to receive our warranty bulletins by e-mail.



